

Description

- The SJ73Lxxx prevents the error of system from supply voltage below normal voltage level at the time of the power on and instantaneous power off in systems.

Features

- Current Consumption is Low ($I_{CCL}=300 \mu A$ Typ. $I_{CCH}=30 \mu A$ Typ.)
- Resetting Output Minimum Guarantee Voltage is Low (0.8V Typ.)
- Hysteresis Voltage is Provided (50 mV Typ.)
- Open Collector Output Configuration

Equivalent Circuit

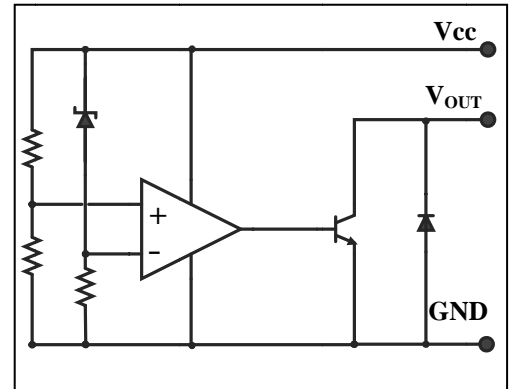

Applications

- As Control Circuit of Battery-Backed Memory
- As Measure Against Erroneous Operations at Power On-Off
- As Resetting Function for the CPU-Mounted Equipment --- PC, Printer, DVD, STB, Fax, C-TV etc.
- As Measure Against System Runaway at Instantaneous Break of Power Supply etc.

Ordering Information

Type NO.	Marking	Package Code
SJ73Lxxx	L □ □ □ ① ② ③	SOT-23
	73L □ □ □ ① ② ③	SOT-89 TO-92M / TO-92

③ Device Code ② Detecting Voltage Code ----- (First Line)

③ Year&Week Code ----- (SOT-23: First Line, SOT-89/TO-92M/TO-92 : Second Line)

Pin Assignment (Marking Side View)

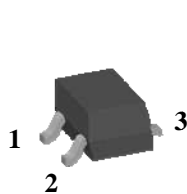

SJ73LxxS
1. : V_{OUT}
2. : V_{CC}
3. : GND

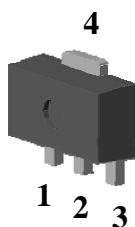

SJ73LxxF
1. : V_{CC}
2. : GND
3. : V_{OUT}
4. : GND



SJ73LxxM
1. : V_{CC}
2. : GND
3. : V_{OUT}



SJ73Lxx
1. : V_{CC}
2. : GND
3. : V_{OUT}

Maximum ratings

(Ta=25°C)

Characteristic		Symbol	Ratings	Unit
Supply Voltage		V _{CC}	-0.3 ~ +15	V
Power Dissipation	SJ73LxxS	P _D	300	mW
	SJ73LxxF		500	
	SJ73Lxx		625	
	SJ73LxxM		400	
Output Voltage		V _{OUT}	-0.3 ~ +15	V
Operating Temperature Range		T _{OPR}	-30 ~ +85	°C
Storage Temperature Range		T _{STG}	-55 ~ +150	°C

* With PCB(50mm² copper area) at glass epoxy board (t=1.7mm, area=50×50mm)

Electrical Characteristics

(Ta=25°C)

Characteristic	Symbol	Test Circuit	Test Condition	Min.	Typ.	Max.	Unit	
Detecting Voltage	V _S	1	R _L =200Ω V _{CC} =H→L V _{OL} ≤0.4V	SJ73L19x	1.75	1.90	2.05	V
				SJ73L21x	1.95	2.10	2.25	
				SJ73L23x	2.15	2.30	2.45	
				SJ73L25x	2.35	2.50	2.65	
				SJ73L27x	2.55	2.70	2.85	
				SJ73L29x	2.75	2.90	3.05	
				SJ73L31x	2.95	3.10	3.25	
				SJ73L32x	3.05	3.20	3.35	
				SJ73L33x	3.15	3.30	3.45	
				SJ73L34x	3.25	3.40	3.55	
				SJ73L35x	3.35	3.50	3.65	
				SJ73L36x	3.45	3.60	3.75	
				SJ73L39x	3.75	3.90	4.05	
				SJ73L42x	4.05	4.20	4.35	
SJ73L45x	4.35	4.50	4.65					
Hysteresis Voltage	ΔV _S	1	R _L =200Ω, V _{CC} =L→H→L	30	50	100	mV	
Temperature Coefficient of Detecting Voltage	V _S /ΔT	1	R _L =200Ω, Ta= -30 ~ +75°C	-	±0.01	-	%/°C	
Low Level Output voltage	V _{OL}	1	R _L =200Ω, V _{CC} =V _S Min-0.05V	-	-	0.4	V	
Output Leakage Current	I _{LEAK}	1	V _{OUT} =15V	-	-	0.1	μA	
Circuit Current at ON	I _{CCL}	1	V _{CC} = V _S Min - 0.05V	-	300	500	μA	
Circuit Current at OFF	I _{CCH}	1	V _{CC} = 5.25V	-	30	50	μA	
Threshold Operating Voltage	V _{OPR}	1	R _L =200Ω, V _{OL} ≤0.4V	-	0.8	1.6	V	
Output Current at ON I	I _{OL I}	1	R _L =0Ω, V _{CC} = V _S Min - 0.05V	20	-	-	mA	
Output Current at ON II	I _{OL II}	1	R _L =0Ω, V _{CC} = V _S Min - 0.05V Ta= -30 ~ +75°C	16	-	-	mA	
L→H Transmission delay time	t _{PLH}	2	R _L =1.0 kΩ, C _L =100 pF	-	15	-	μs	
H→L Transmission delay time	t _{PHL}	2	R _L =1.0 kΩ, C _L =100 pF	-	10	-	μs	

Application Circuit

Test Circuit 1

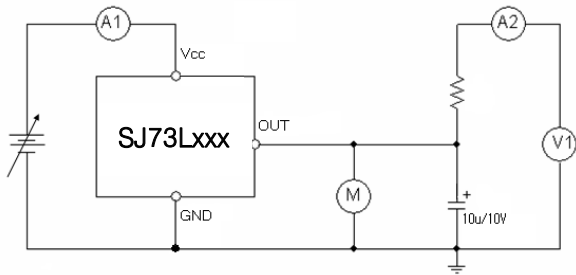

Test Circuit 2

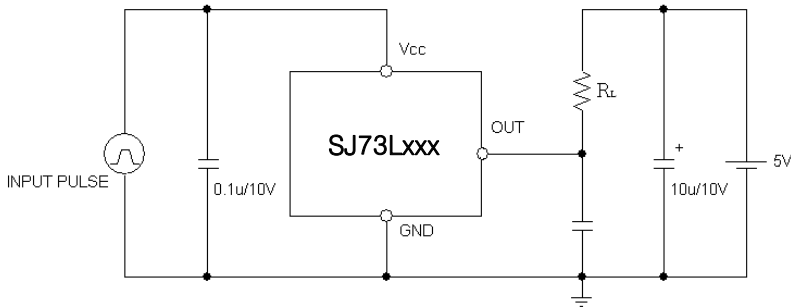

(1) Battery Low Indicator

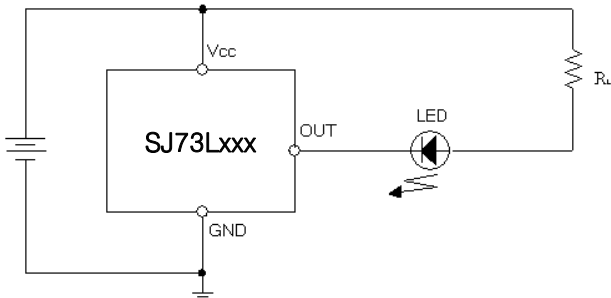

Note 1. : Connecting of LED and R2 obtains a voltage drop indicator.

(2) Resetting for CPU

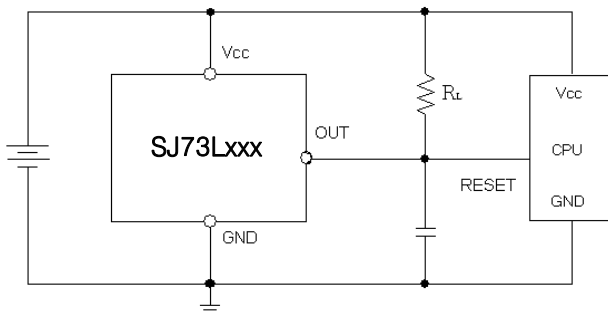

Electrical Characteristic Curves

Fig. 1 $V_{OUT} - V_{CC}$

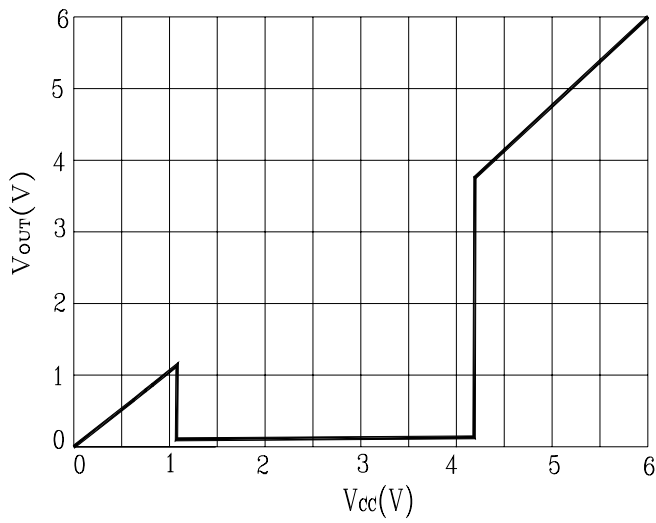

Fig. 2 $I_{CC} - V_{CC}$

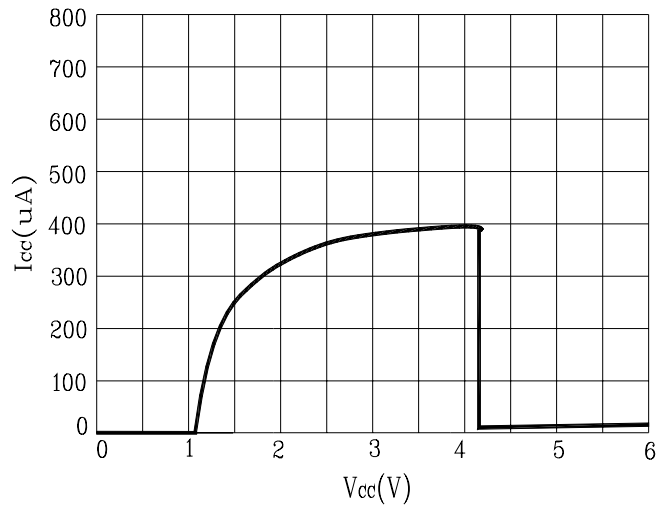

Fig. 3 $I_{CCH} - T_a$

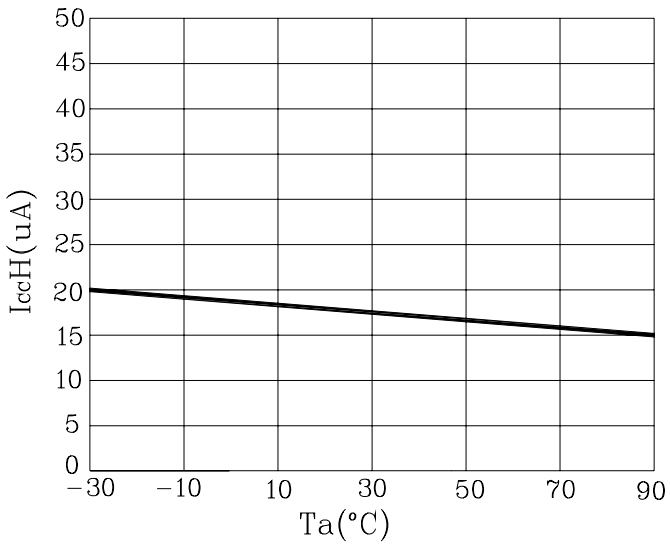
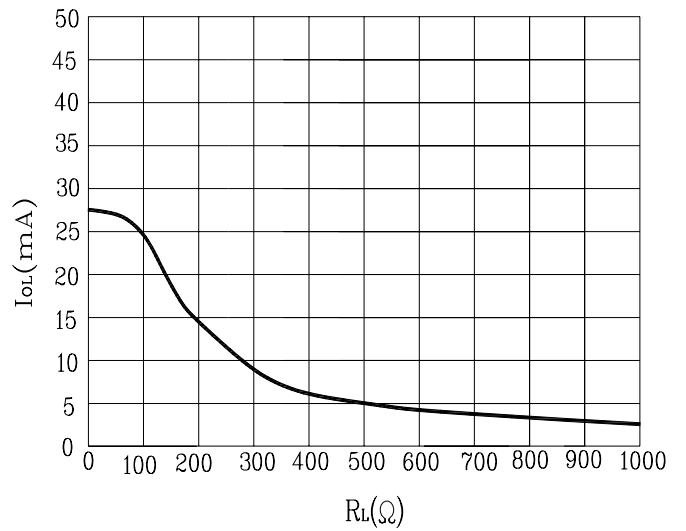
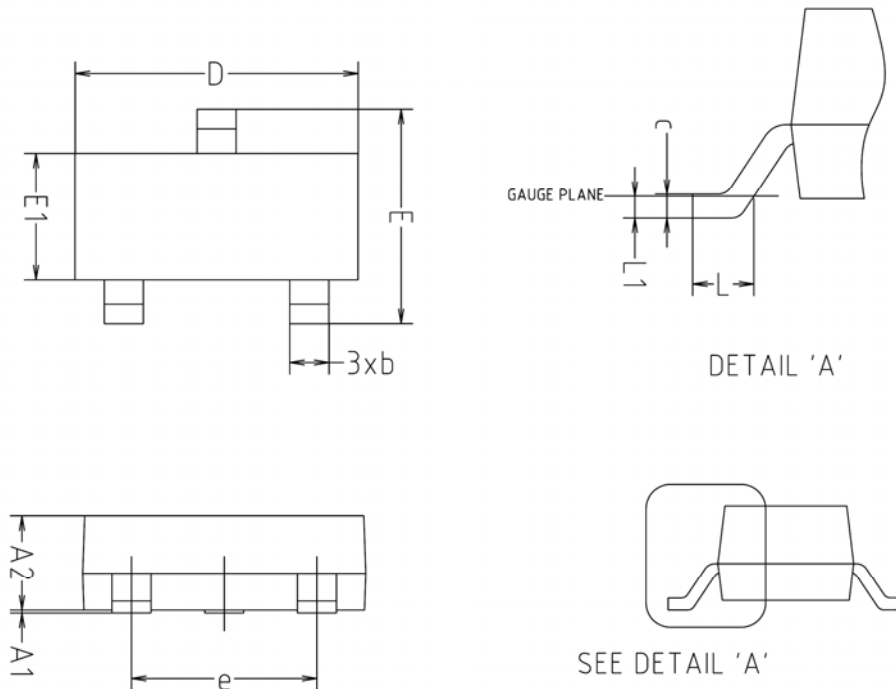

Fig. 4 $I_{OL} - R_L$



Outline Dimension (Unit : mm)



SYMBOL	MILLIMETERS			NOTE
	MINIMUM	NOMINAL	MAXIMUM	
A1	0.00	-	0.10	
A2	0.82	-	1.02	
b	0.39	0.42	0.45	
c	0.09	0.12	0.15	
D	2.80	2.90	3.00	
E	2.20	2.40	2.60	
E1	1.20	1.30	1.40	
e	1.90BSC			
L	0.20	-	-	
L1	0.12BSC			

Recommend PCB Solder Land Dimension (Unit : mm)

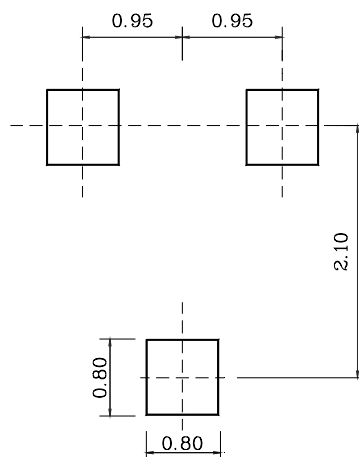

Outline Dimension (Unit : mm)

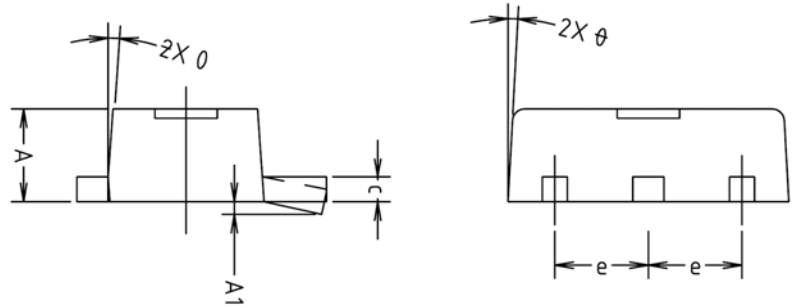
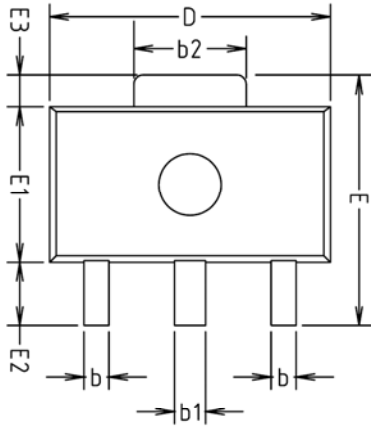

SYMBOL	MILLIMETERS			NOTE
	MINIMUM	NOMINAL	MAXIMUM	
A	1.40	1.50	1.60	
A1	0.00	-	0.10	
b	0.38	0.42	0.48	
b1	0.48	0.52	0.58	
b2	1.79	1.82	1.87	
c	0.40	0.42	0.46	
D	4.40	4.50	4.70	
E	3.70	4.00	4.30	
E1	2.40	2.50	2.70	
E2	0.80	1.00	1.20	
E3	0.40	0.50	0.60	
e	1.50 TYP.			
theta	4° TYP.			

Recommend PCB Solder Land Dimension (Unit : mm)

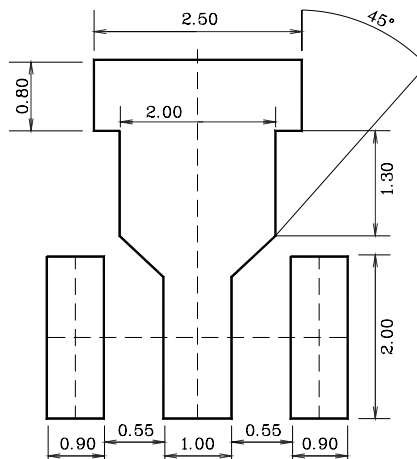

Outline Dimension (Unit : mm)

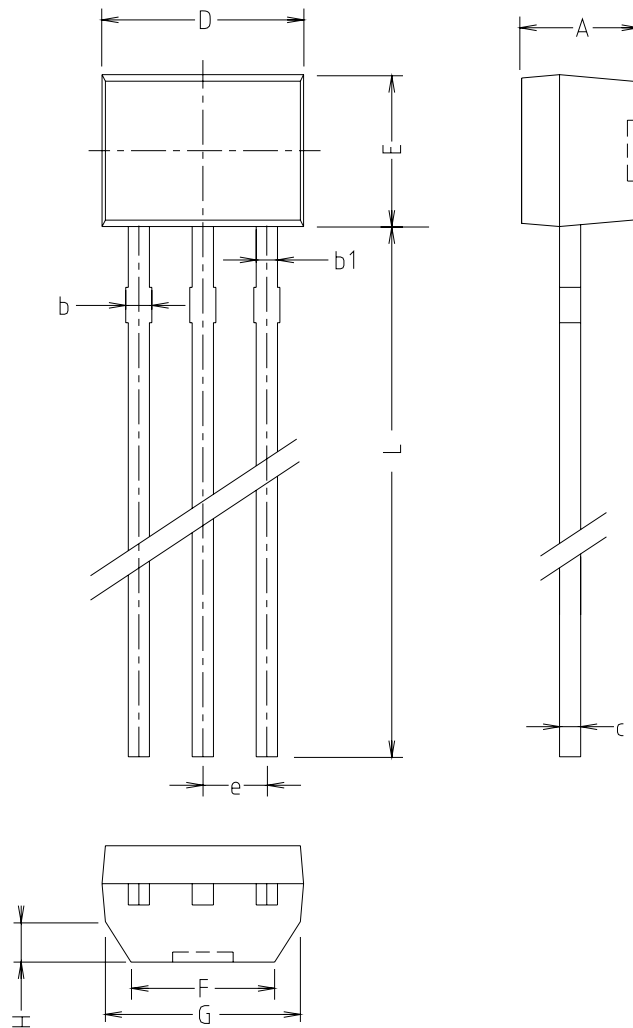

SYMBOL	MILLIMETERS(mm)		
	MINIMUM	NOMINAL	MAXIMUM
A	2.20	2.30	2.40
b	-	0.50	-
b1	-	0.44	-
c	-	0.42	-
D	3.90	4.00	4.10
E	2.90	3.00	3.10
e	-	1.27	-
L	-	14.50	15.00
F	2.80	2.85	2.90
G	3.80	-	-
H	-	0.70	-

Outline Dimension (Unit : mm)

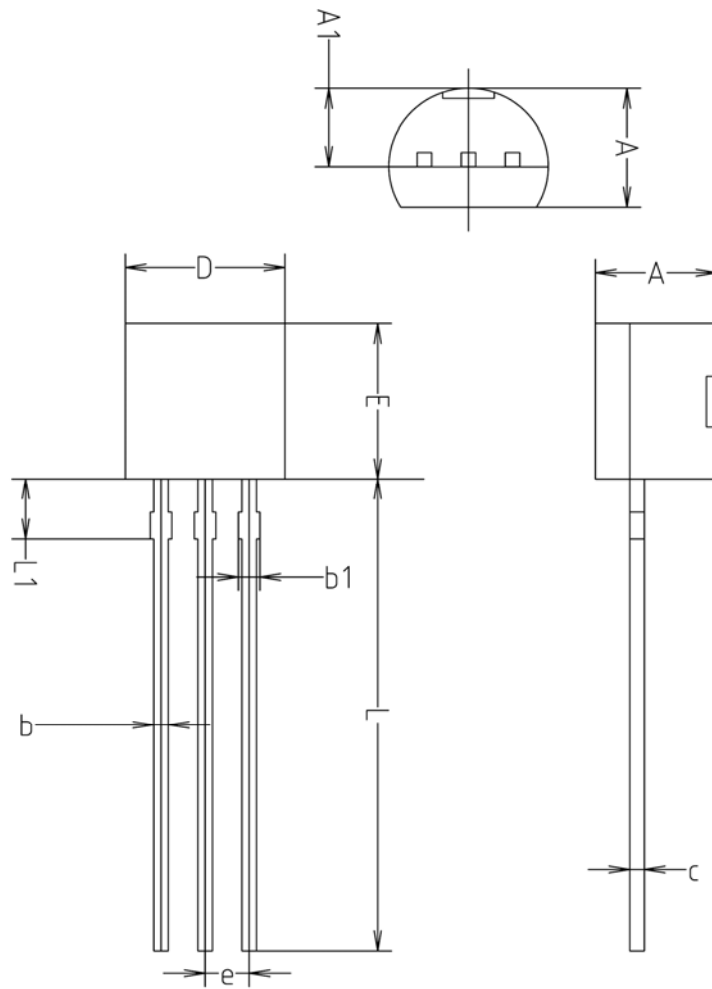

SYMBOL	MILLMETERS(mm)		
	MINIMUM	NOMINAL	MAXIMUM
A	3.40	3.50	3.66
A1	2.46	2.51	2.59
b	0.39	0.44	0.53
b1	0.39	-	0.63
c	0.35	0.42	0.47
D	4.48	4.60	4.70
E	4.48	4.60	4.70
e	1.17	1.27	1.37
L	13.70	14.00	14.77
L1	1.55	1.70	2.15

The AUK Corp. products are intended for the use as components in general electronic equipment (Office and communication equipment, measuring equipment, home appliance, etc.).

Please make sure that you consult with us before you use these AUK Corp. products in equipments which require high quality and / or reliability, and in equipments which could have major impact to the welfare of human life(atomic energy control, airplane, spaceship, transportation, combustion control, all types of safety device, etc.). AUK Corp. cannot accept liability to any damage which may occur in case these AUK Corp. products were used in the mentioned equipments without prior consultation with AUK Corp..

Specifications mentioned in this publication are subject to change without notice.

표준제목	SJ73Lxxx		코드 (CODE)	KSD-I5C011		
			개정번호 (REVISION)	002	페이지 (PAGE)	10/10
(REVISION HISTORY) 개정이력	개정일자	개정	내용		기안자	승인자
	2010.02.23	000	신규제정		구성훈	최재훈
	2010.09.06	001	3사 통합에 따른 CI변경		구성훈	최재훈
	2010.11.02	002	TO-92 Package 파생 [전체 Value 적용]		구성훈	최재훈
(NOTIFICATION) 배지면	이 표준은 표준화 규정 (KRB-3002) 및 동부속규정에서 정하는 승인 절차에 따라 등록 되었음을 확인 하고 그 사본은 배포함.		I HEREBY CERTIFY THAT THE ATTACHED COPY IS CORRECT, WHICH HAS BEEN REPRODUCED FROM THE ORIGINAL COPY CONTROLLED AND APPROVED IN ACCORDANCE WITH THE COMPANY REGULATION (KRB-3002) AND IT'S APPENDIX			
	SPECIFICATION CENTER					
관련문서 (REFERENCE)			실시일자 (EFFECTIVE)	등록 후 배포		
			파기일자	영구		