

# GOT-3126TL-830

12.1" SVGA TFT Extended Temp. Fanless Touch Panel Computer with Intel® Atom™ Processor (-20°C +55°C)

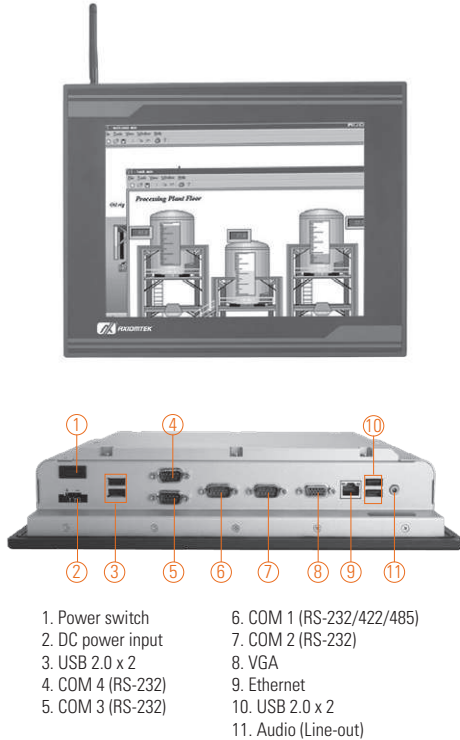

## Features

- 12" SVGA (800 x 600) color TFT LCD display
- Fanless cooling system with Intel® Atom™ N270 1.6 GHz
- Supports wide temperature range of -20°C +55°C
- Anti-vibration up to 1.3G (HDD, random)
- Supports WLAN antenna (optional)
- Easy for expansion: Mini Card
- Over-current protection-fuse
- Supports panel mount, wall mount, VESA arm, desktop stand (optional)



## Introduction

GOT-3126TL is the 12.1 fanless touch panel computer. By supporting a wide temperature range from -20°C to +55°C, the GOT-3126TL is especially designed for harsh environments. The GOT-3126TL adopts a modern, super sleek fanless design, is equipped with a 12.1" TFT LCD, and low power consumption Intel® Atom™ processor. In response to customer's requests for wireless applications, the GOT-3126TL has a Mini Card slot and an optional fixed rotational WLAN antenna for wireless network connection. By just plugging in the Mini Card WLAN card, customers have instant access wireless LAN. The GOT-3126TL is suitable for many applications including transportation, train, control platforms on ships, oil pipe monitoring systems, and environmental monitoring of steelworks.

### Wide-temperature (-20°C~ +55°C) supported

The GOT-3126TL adopts unique extended temperature technology, with a temperature range from -20°C to +55°C, with a fanless cooling system and compact design for harsh environments.

### Super slim design: 69mm

The GOT-3126TL is a super slim fanless touch panel computer for limited space environments. This fanless touch panel computer is designed around the concept of curved lines and soft edges by incorporating an ULV Intel® Atom™ processor and a streamlined mechanical layout.

### WLAN antenna supported (optional)

The GOT-3126TL provides a Mini Card slot and an optional fixed rotational WLAN antenna for wireless network connections. By simply plugging in the wireless LAN card, customers can use the unit in a wireless environment.

### Anti-vibration up to 1.3G

With a special vibration-resistant design patent, GOT-3126TL can work well under 1.3G (5-500Hz) in operation mode, and equipped with a 2.5 HDD.

## Specifications

Front Bezel	IP65, NEMA 4 rugged protection, aluminum front bezel	
LCD Panel	Display Type	12.1" SVGA TFT LCD
	Brightness (cd/m <sup>2</sup> )	450 nits
	Resolution	800 x 600
	View Angle (H/V)	160°/140°
Main System	CPU	Intel® Atom™ processor N270 1.6 GHz
	Chipset	Intel® 945GSE-ICH7M
	System Memory	1 x 200-pin DDR2 533 SO-DIMM max. up to 2 GB
	BIOS	AMI 8 Mbit with RPL/PXE LAN boot ROM
	Storage	1 x 2.5" SATA HDD 1 x CompactFlash™
	Watchdog Timer	255 levels, 0-255 sec.
	Onboard Graphics	Integrated Intel® 945GSE

## Specifications

I/O Connector	3 x RS-232 (COM 2/3/4) 1 x RS-232/422/485 (COM 1) 1 x VGA 1 x Audio (Line-out) 4 x USB 2.0 1 x 10/100/1000Mbps Ethernet
Expansion Interface	1 x PCIe Mini Card
Touchscreen	Resistive type
Power Supply	12/24VDC, 36W, w/ fuse power protection
Dimensions	332 mm (13") (W) x 70.5 mm (2.77") (D) x 267 mm (10.5") (H)
Packing Dimensions	510 mm (20.08") (W) x 190 mm (7.48") (D) x 540 mm (21.26") (H)
Weight (net/gross)	4.6 kg (10.14 lb)/6.4 kg (14.1 lb)
Environment	Operating temperature: -20°C ~ +55°C (-4°F ~ 131°F) (with W.T. DRAM/HDD/CF) Storage Temperature: -30°C ~ +80°C (-22°F ~ +176°F) Relative humidity: 10% ~ 95% @ 40°C; non-condensing Operation vibration: 1.3G, 5 ~ 500Hz, random for 2.5" HDD 2G, 5 ~ 500Hz, random for CompactFlash™
Certification	CE

\* W.T.: Wide Temperature. All W.T. supported products have to be sorted by Axiomtek.

## Ordering Information

GOT-3126TL-830	12.1 SVGA TFT fanless touch panel computer with Intel® Atom™ N270 (-20°C~ +55°C)
Wall/VESA kit	Wall/VESA mount kit for GOT-3126TL
Desktop stand	Desktop stand kit for GOT-3126TL
Wireless	802.11 b/g wireless LAN kit
50966A23040E	Power adapter, 70W, 110-230VAC to 24VDC

\* Specification and certifications are based on options and may vary.

## Optional EOS Installation

Window® XP Embedded
Windows® CE.NET

## Optional OS Installation

Windows® XP
-------------

Overview

Industrial Panel Computers & Monitors

Heavy-duty Fanless Touch Panel Computers

Digital Signage Solutions

Healthcare & Medical Solutions

Open Frame Panel Computers

Accessories

## Dimensions

