

P1158-822

15" XGA Intel® Pentium® M Slim Industrial Panel Computer

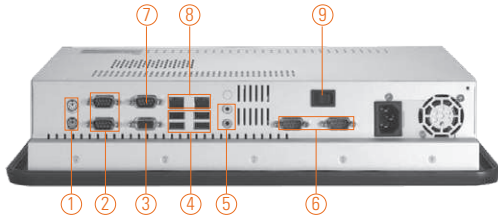

- | | |
|----------------------------|---------------------|
| 1. PS/2 K/B+M/S x 2 | 6. COM 5/6 (RS-232) |
| 2. COM 1/2 (RS-232) | 7. COM3 (RS-232) |
| 3. VGA | 8. Ethernet x 2 |
| 4. USB 2.0 x 4 | 9. Power switch |
| 5. Audio (Mic-in/Line-out) | |

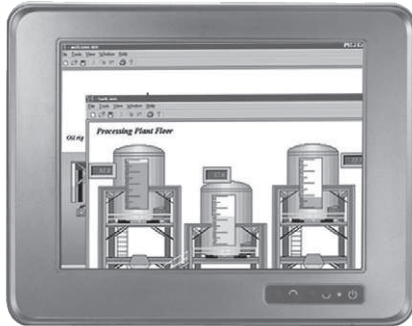

DualView

Introduction

The P1158-822 is a 15" multi-media panel PC for kiosk application. It has a fashionable mechanism design and industrial-grade material front bezel which can avoid damage from chemical corrosion. To meet the demand of multimedia application, the P1158-822 supports Intel® Pentium® M and Celeron® M processor and incorporates two Gigabit Ethernet and WLAN for wireless network connection. This slim industrial panel PC is most suitable for kiosk, factory automation and more.

Industrial-grade front bezel

The P1158-822 adopts industrial-grade material front bezel which incorporates the advantages of light weight, high degree of hardness, better heat releasing, easy-to-shape and anti-corrosion ability. Therefore, the P1158-822 is especially suitable for most rugged industrial environments.

Features

- 15" XGA TFT LCD display
- Industrial-grade material front bezel: anti-corrosion
- Slim design: 86 mm
- Supports panel mount, rack mount, VESA arm, desktop stand
- Supports dimming control



▲ Side view

Specifications

Front Bezel	IP65, NEMA 4 rugged protection, Industrial-grade material front bezel		
LCD Panel	Display Type	15" XGA TFT LCD	
	Brightness (cd/m ²)	250 nits	
	Resolution	1024 x 768 pixels	
	Viewing Angle (H/V)	140°/120°	
Main System	CPU	Socket 478 for Intel® Pentium® M/ Celeron® M processor with FSB 400 MHz	
	Chipset	Intel® 910GML + ICH6M	
	System Memory	2 x 240-pin DDR2 DIMM max. up to 2 GB	
	BIOS	Award 4Mbit with RPL/PEX LAN boot ROM, Smartview and customer CMOS backup	
	Storage	1 x 3.5" or 2 x 2.5" SATA HDD	
	Watchdog Timer	255 levels, 1~255 sec.	

Specifications

I/O Connector	5 x RS-232 (COM 1-5) 4 x USB 2.0 2 x PS/2 keyboard/mouse 2 x 10/100/1000Mbps Ethernet 1 x Audio (Mic-in/Line-out) 1 x D-sub 15-pin for VGA output
Touchscreen	5-wire resistive type Light Transmission 79% 1 million activations (typical) at a single point
Power Supply	100 ~ 240VAC, 180W
Dimensions	420 mm (16.54") (W) x 86.4 mm (3.40") (D) x 335 mm (13.2") (H)
Packing Dimensions	610 mm (24.02") (W) x 260 mm (10.24") (D) x 590 mm (23.23") (H)
Weight (net/gross)	5.5 kg (12.1 lb)/9.3 kg (20.5 lb)
Environment	Operating temperature: 0° ~ +45°C (32°F ~ 113°F) Storage Temperature: -20°C ~ +65°C (-4°F ~ +149°F) Relative humidity: 10% ~ 95% @ 40°C, non-condensing Operation vibration: 1.0G, 5-500Hz, random
Certification	CE, FCC, UL60950

Ordering Information

P1158-822	15" XGA TFT socket 478 Intel® Pentium® M slim industrial panel PC
-----------	---

* Specification and certifications are based on options and may vary.

Optional Accessories

82211580080E	2.5" HDD kit
82211580090E	VESA ARM kit
82211530110E	Wireless LAN kit
E202003330	VM-101 (VESA ARM clamp type)
E202003329	VM-105 (VESA ARM wall-mount)
82261580070E	Rack mount kit

Optional OS Installation

Windows® XP/Vista

Overview

Industrial Panel Computers & Monitors

Heavy-duty Fanless Touch Panel Computers

Digital Signage Solutions

Healthcare & Medical Solutions

Open Frame Panel Computers

Accessories

Dimensions

