





The DCSA Series is a loop-powered, linear output current transducer that provides an output that is directly proportional to the RMS AC current passing through the LCSC10T12 sensor. The DCSA provides either an analog current or voltage: 4 - 20 mA, 1 to 5VDC, or 2 to 10VDC. Each unit is factory calibrated for monitoring (with the LCSC10T12 connected) in one of four ranges; 0 - 5, 0 - 10, 0 - 20, or 0 - 50A. Zero and span adjustments allow field calibration if needed. The DCSA mounts on both DIN 1 and DIN 3 rails.

For more information see:
Appendix B, page 166, Figure 22 for dimensional drawing.
Appendix C, page 169, Figure 21 for connection diagram.

Features:

- Mounts on DIN 1 or DIN 3 rail
 - 0 - 50A in 4 ranges using LCSC10T12 sensor
 - Loop powered from 10 to 30VDC
 - Linear output from 4 - 20mA, 1 - 10VD
 - Zero & span adjustments
 - Separate sensor & control unit
- Approvals:   

Auxiliary Products:

- **Current sensor:**
P/N: LCSC10T12

Available Models:

DCSA50
LCSC10T12

If desired part number is not listed, please call us to see if it is technically possible to build.

Operation

The DCSA varies the effective resistance of its output in direct proportion to the current flowing in the conductor monitored by the LCSC10T12. Connecting the power supply to terminals C & D provides a 4 to 20mA DC current. Connect the power supply to terminals C & A to get 1 to 5VDC at terminal D. Connect the power supply to terminals C & B to get 2 to 10VDC at terminal D.

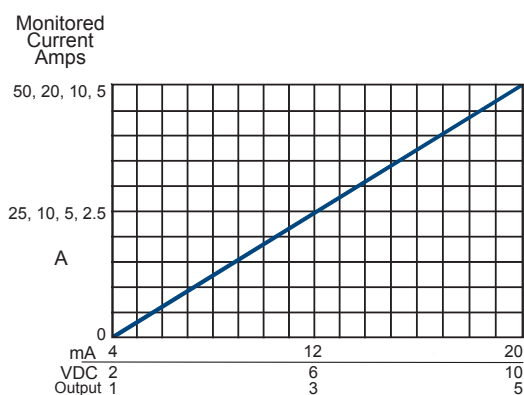

Order Table:

<u>Current Range with LCSC10T12</u>	<u>DCSA Input Range (F to E)</u>	<u>Part Number</u>
0-5A	0-5mA AC	DCSA5
0-10A	0-10mA AC	DCSA10
0-20A	0-20mA AC	DCSA20
0-50A	0-50mA AC	DCSA50

Toroidal Current Sensor LCSC10T12

Specifications

Input	
Ranges (without LCSC10T12 connected)	
4 factory calibrated ranges in mA AC	0 - 5mA, 0 - 10mA, 0 - 20mA, or 0 - 50mA AC
Factory calibration	±0.5% of full scale
Repeat Accuracy	±0.25% of full scale under fixed conditions
Response Time	≅ 300ms
Temperature Coefficient	±0.05%/°C
Input To Output	Not isolated
Output	
Type	Analog
Range	Current directly proportional to input current
Supply Voltage*	4 - 20mA, or 1 to 5VDC or 2 to 10VDC
Momentary Voltage	10 to 30VDC
Zero Adjust	40VDC for 1m
Span Adjust	≅ 3.75 - 4.25mA
Adjustment	18mA - 22mA
Protection	Mini-screw, multi-turn potentiometer
Dielectric Breakdown	≥ 2500V RMS terminals to mounting surface
Insulation Resistance	≥ 100 MΩ
Polarity	Units are reverse polarity protected

Mechanical	
Mounting	DIN 1 & DIN 3 rail mounting
Termination	Wire clamp For 22 - 14AWG (.336 mm ² ... 2.5 mm ²)
Environmental	
Operating / Storage Temperature	-30° to 60°C / -40° to 85°C
Humidity	95% relative, non-condensing
Weight	≅ 1.6 oz (45.4 g)

Accessory - LCSC10T12 Toroidal Sensor	
Number of Turns	1000
Nominal Output Current Full Range	0 - 50 mA
Maximum Allowable Current	Steady 50A turns
	Inrush 300A turns for 10s
Burden	≤ 0.5 VA
Frequency	0 - 20A / 21 - 50A 20/100 Hz / 30/100 Hz
Sensor Hole	0.36 in. (9.14 mm) for up to #4 AWG (21.1 mm ²) THHN wire
Weight	≅ 1 oz (28.3 g)

*Minimum loop-power supply voltage equals the minimum sensor voltage 10VDC plus the voltage drop developed across all the other loop devices at 20mA.

Appendix B - Dimensional Drawings

FIGURE 13

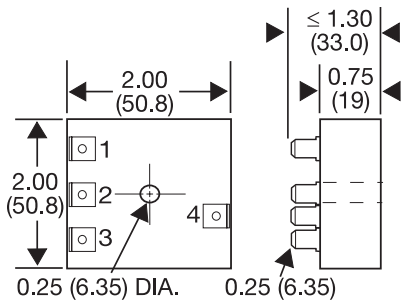

AF

FIGURE 14

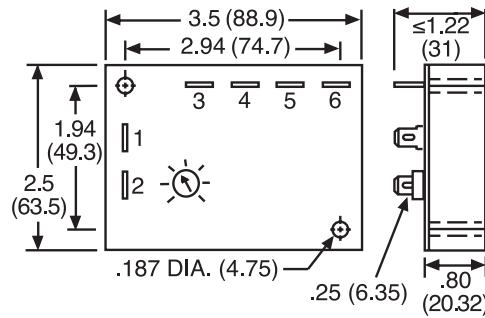

SC3; SC4; SQ

FIGURE 15

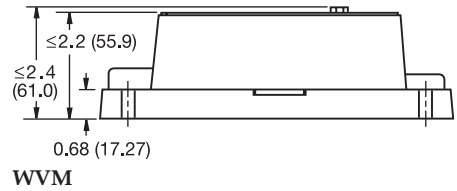
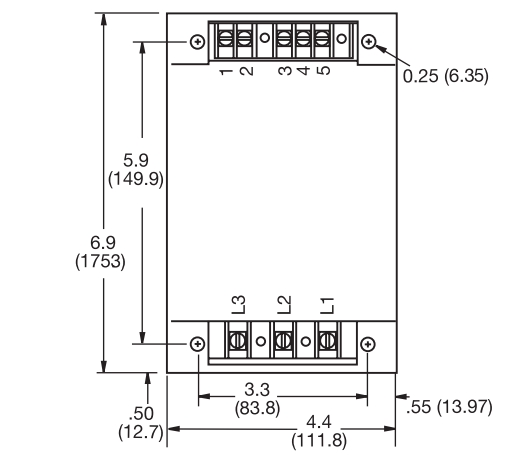

WVM

FIGURE 16

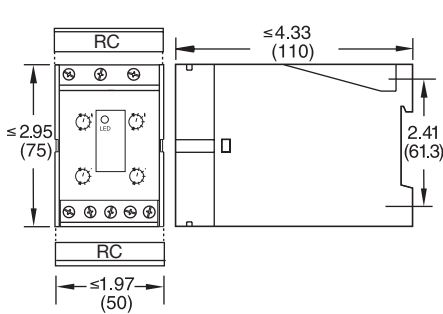

DLMU

FIGURE 17

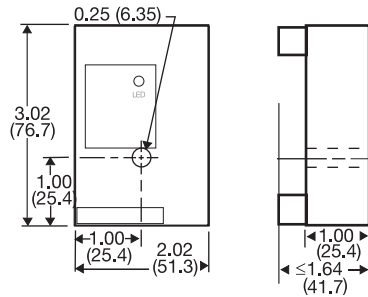

FB9L; HLMU; SCR9L

FIGURE 18

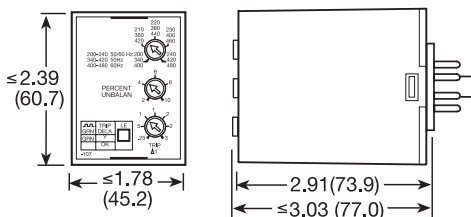

PLMU

FIGURE 19

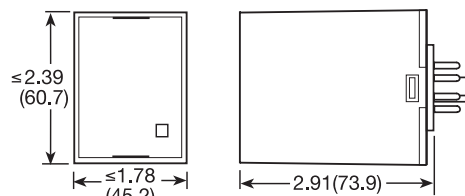

LLC4; LLC6; PLS

FIGURE 20

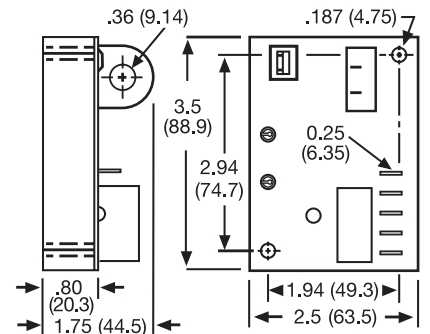

ECS; ECSW (ECS has spade connectors and ECSW has terminal board)

FIGURE 21

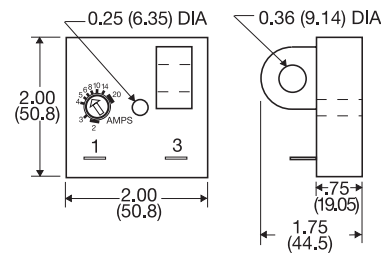

TCS; TCSA

FIGURE 22

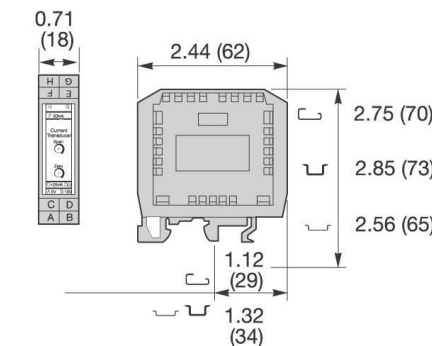

DCSA

FIGURE 23

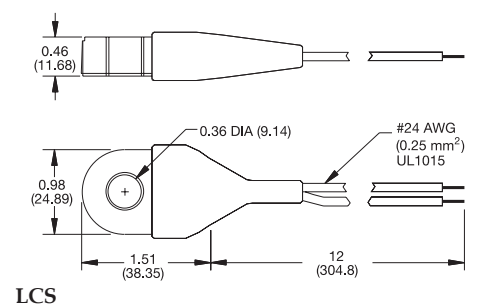

LCS

inches (millimeters)

Appendix C - Connection Diagrams

FIGURE 15 - HLV Series

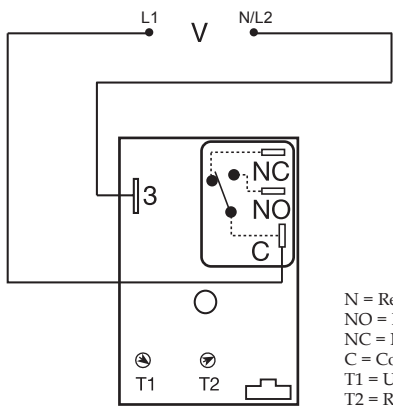

N = Relay contacts are non-isolated.
 NO = Normally Open
 NC = Normally Closed
 C = Common
 T1 = Undervoltage Trip Point
 T2 = Restart Delay

FIGURE 16 - KVM Series

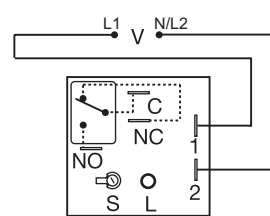

V = Voltage
 L = LED
 S = Undervoltage Setpoint
 NO = Normally Open
 NC = Normally Closed
 C = Common, Transfer Contact

FIGURE 17 - ECS Series

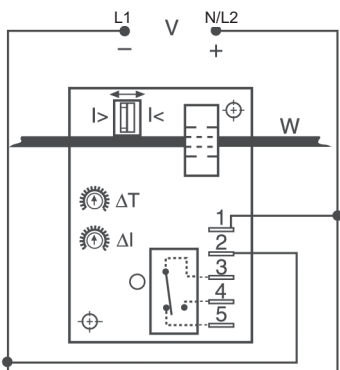

V = Voltage
 W = Insulated Wire Carrying Monitored Current
 I> = Overcurrent
 I< = Undercurrent
 Relay contacts are isolated.

FIGURE 18 - ECSW Series

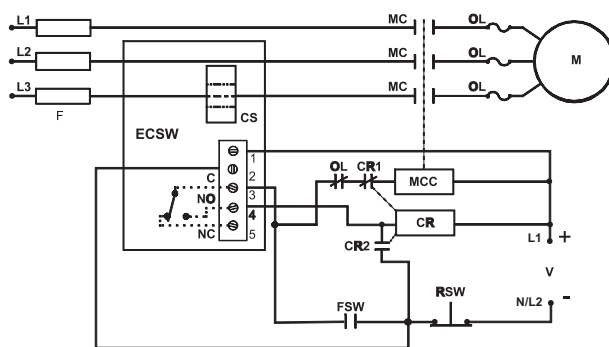

MC = Motor Contactor
 M = Motor
 F = Fuses
 OL = Overload
 RSW = Reset Switch
 FSW = Fan or Float Contacts
 CR = Control Relay
 CS = Current Sensor
 MCC = Motor Contactor Coil

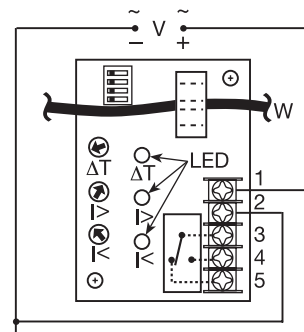

V = Voltage
 I> = Adjustable Overcurrent
 I< = Adjustable Undercurrent
 W = Monitored Wire
 ΔT = Adjustable Trip Delay

FIGURE 19 - TCS Series

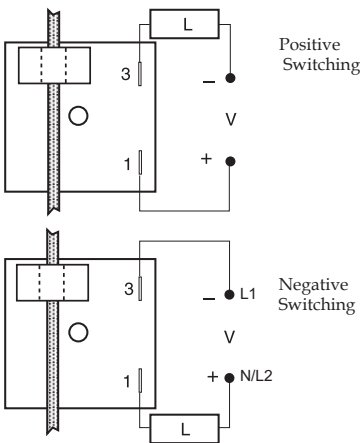

Positive Switching

Negative Switching

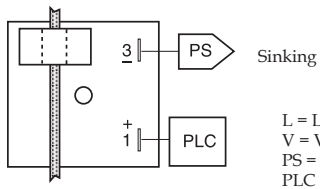

Sinking

L = Load
 V = Voltage
 PS = Power Supply
 PLC = PLC Digital Input Module

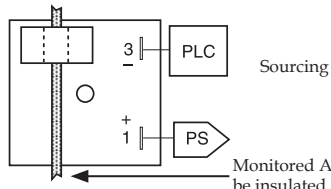

Sourcing

Monitored AC conductor must be insulated.

FIGURE 20 - TCSA Series

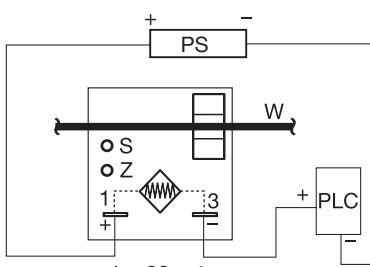

4... 20 mA
 PS = Power Supply
 Z = Zero Adjust
 S = Span Adjust
 W = Insulated Wire Carrying Monitored Current
 PLC = PLC Analog Input or Meter Input

FIGURE 21 - DCSA Series

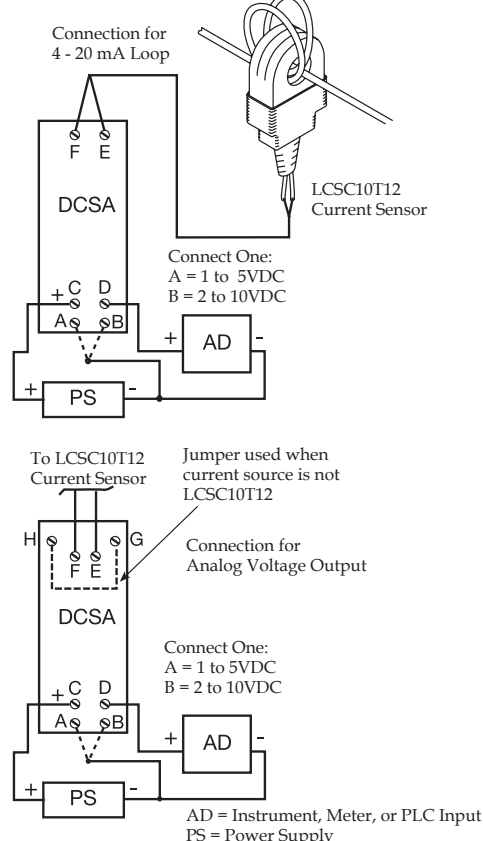

Connection for 4 - 20 mA Loop

LCSC10T12 Current Sensor

Connect One:
 A = 1 to 5VDC
 B = 2 to 10VDC

To LCSC10T12 Current Sensor
 Jumper used when current source is not LCSC10T12
 Connection for Analog Voltage Output

Connect One:
 A = 1 to 5VDC
 B = 2 to 10VDC

AD = Instrument, Meter, or PLC Input
 PS = Power Supply