

The FS100 Series (medium amp) may be used to control inductive, incandescent, or resistive loads. Input voltages of 24, 120, or 230VAC are available. Factory fixed flash rate of 90 FPM or may be ordered with a fixed, custom flash rate ranging from 10 to 300 FPM. Encapsulation provides protection against shock, vibration, and humidity. This group of solid-state flashers has proven reliability with years of use throughout the world.

Operation

Upon application of input voltage, the T2 OFF time begins. At the end of the OFF time, the T1 ON time begins and the load energizes. At the end of T1, T2 begins and the load de-energizes. This cycle repeats until input voltage is removed.

Reset: Removing input voltage resets the output and the sequence to T2.

For more information see:

- Appendix A, page 164 for Flasher (OFF First) function.
- Appendix B, page, 165, Figure 1 for dimensional drawing.
- Appendix C, page 168, Figure 3 for connection diagram.

Order Table:

Input Voltage	Rating	Part Number
24VAC	3A	FS143
120VAC	3A	FS152
230VAC	3A	FS162

Add the suffix "-##" to any part number to indicate the custom flash rate.

Specifications

Technical Data

Operation	OFF/ON solid-state flasher (continuous duty)
Flash Rate	Fixed at 90 FPM ±10%
Custom Flash Rates	10 - 300 FPM ±10%
ON/OFF Ratio	≅ 50%

Input

Voltage/Frequency 24, 120, or 230VAC ±15%/50/60 Hz

Output

Load Type Inductive, resistive, or incandescent
Output Fullwave AC, solid state, SPST

Maximum Load Rating 3A steady state
Inrush 10 times steady state current

Mechanical

Mounting Surface mount with one #10 (M5 x 0.8) screw
Dimensions 2 x 2 x 1.21 in. (50.8 x 50.8 x 30.7 mm)
Termination 0.25 in. (6.35 mm) male quick connect terminals

Protection

Circuitry Encapsulated

Environmental

Operating / Storage Temperature -20° to 60°C / -40° to 85°C
Weight ≅ 2.2 oz (62 g)

Features:

- Fixed at 90 FPM
- Custom flash rate 10 - 300 FPM
- Switches inrush currents up to 30A
- 24, 120, or 230VAC input voltages
- Totally solid state & encapsulated

Approvals:

Auxiliary Products:

- **Female quick connect:**
P/N: P1015-64 (AWG 14/16)
- **Quick connect to screw adaptor:**
P/N: P1015-18
- **Mounting bracket:** P/N: P1023-6
- **DIN rail:** P/N: C103PM (Al)
- **DIN rail adaptor:** P/N: P1023-20

Available Models:

FS143	FS152-60
FS152	FS162
FS152-30	FS162-30
FS152-50	

If desired part number is not listed, please call us to see if it is technically possible to build.

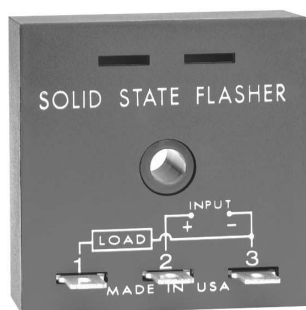

The FS200 Series may be used to control inductive, incandescent, or resistive loads. Input voltages of 12, 24, 36, 48, or 110VDC are available. Factory fixed flash rate of 90 FPM or may be ordered with a fixed custom flash rate ranging from 10 to 180 FPM. Encapsulation provides protection against shock, vibration, and humidity. Uniform performance, high inrush current capability, and low RFI, make this series ideal for general industrial applications.

Operation

Upon application of input voltage, the T2 OFF time begins. At the end of the OFF time, the T1 ON time begins and the load energizes. At the end of T1, T2 begins and the load de-energizes. This cycle repeats until input voltage is removed.

Reset: Removing input voltage resets the output and the sequence to T2.

For more information see:

- Appendix A, page 164 for Flasher (OFF First) function.
- Appendix B, page, 165, Figure 1 for dimensional drawing.
- Appendix C, page 168, Figure 4 for connection diagram.

Order Table:

Input Voltage	Rating	Part Number
12VDC ±20%	3A	FS219
24VDC ±20%	3A	FS224
36VDC ±20%	1A	FS236
48VDC ±15%	0.75A	FS248
110VDC ±15%	0.25A	FS290

Specifications

Technical Data

Operation	OFF/ON solid-state flasher (continuous duty)
Flash Rate	Fixed at 90 FPM ±10%
Custom Flash Rate	10 - 180 FPM
ON/OFF Ratio	≅ 50%

Input

Voltage 12, 24, 36, 48, or 110VDC

Output

Load Type Inductive, resistive, or incandescent
Maximum Load Rating 0.25 - 3A steady state
OFF State Leakage Current
12 & 24VDC ≤ 250 μA

Inrush 10 times steady state current

Mechanical

Mounting Surface mount with one #10 (M5 x 0.8) screw
Dimensions 2 x 2 x 1.21 in. (50.8 x 50.8 x 30.7 mm)
Termination 0.25 in. (6.35 mm) male quick connect terminals

Protection

Circuitry Encapsulated

Environmental

Operating / Storage Temperature -20° to 60°C / -40° to 85°C
Weight ≅ 2.2 oz (62 g)

Features:

- Fixed at 90 FPM
- Custom flash rate 10 - 180 FPM
- 3A, SPST output contact
- 12 to 110VDC input voltages in 5 ranges
- Totally solid state & encapsulated
- 0.25 in. (6.35 mm) male quick connects

Auxiliary Products:

- **Female quick connect:**
P/N: P1015-64 (AWG 14/16)
- **Quick connect to screw adaptor:**
P/N: P1015-18
- **Mounting bracket:** P/N: P1023-6
- **DIN rail:** P/N: C103PM (Al)
- **DIN rail adaptor:** P/N: P1023-20

Available Models:

FS224

If desired part number is not listed, please call us to see if it is technically possible to build.

Appendix A - Timer/Flasher Functions

Single Functions

Retriggerable Single Shot

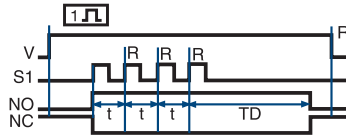
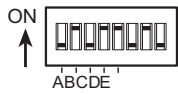

Accumulative Delay-on-Make

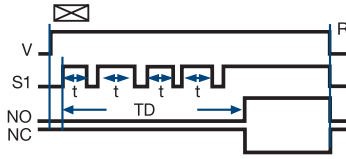
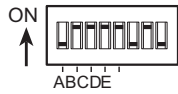

Dual Functions

* Recycle (OFF Time First) Both Times Adjustable

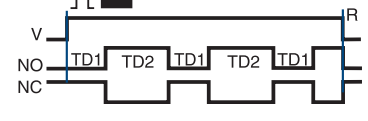
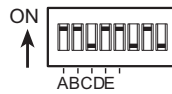

* Interval Delay-on-Make

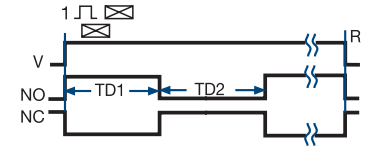
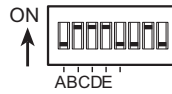

KEY

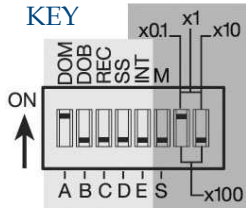

V=Voltage, R=Reset, S1=Initiate Switch, NO=Normally Open Contact, NC=Normally Closed Contact, TD,TD1,TD2=Complete Time Delay, t=Partial Time Delay, DOM=Delay-on-Make, DOB=Delay-on-Break, REC=Recycle, SS=Single Shot, INT=Interval, M=Minutes, S=Seconds, = Undefined time

5 Switches for Function Selection
3 Switches for Time Delay Range

NOTE: The time delay range is the same for both functions when dual functions are selected.

Accumulative Delay-on-Make Interval

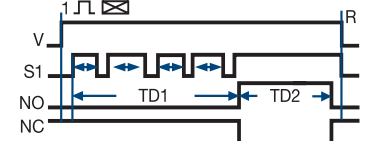
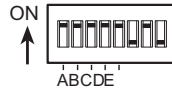

* 9 Functions included in the 8 pin DPDT models

Flasher Function Diagrams

Flasher (NC)

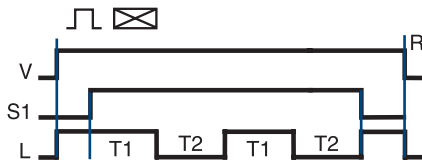

V = Voltage S1 = Initiate Switch L = Load
R = Reset T1 = ON Time T2 = OFF Time
T1 ≅ T2

Flasher (OFF First)

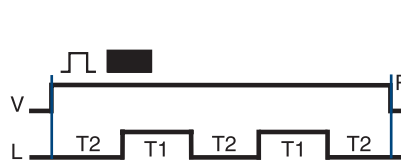

V = Voltage R = Reset L = Load
T1 = ON Time T2 = OFF Time
T1 ≅ T2

Flasher (ON First)

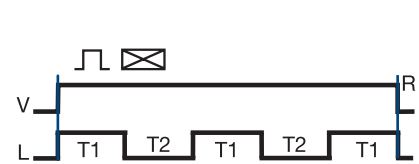

V = Voltage R = Reset L = Load
T1 = ON Time T2 = OFF Time T1 ≅ T2
ON time plus OFF time equals one complete flash.

Flasher (Alternating)

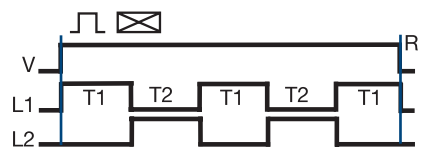

V = Voltage L1 = Load 1 L2 = Load 2
R = Reset T1 = ON Time T2 = OFF Time
T1 ≅ T2

Flasher (ON First-DPDT)

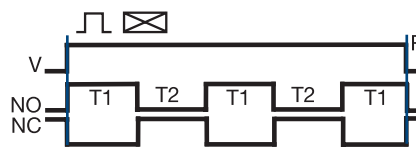

V = Voltage R = Reset
T1 = ON Time T2 = OFF Time
NO = Normally Open NC = Normally Closed

Flasher (Chasing)

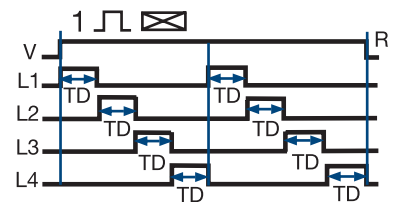

SC4 shown; SC3, L4 is eliminated and L1 TD begins as soon as L3 TD is completed.

V = Voltage R = Reset L (1...4) = Lamps
TD = Time Delay (all are equal)

Flashers & Aux. Modules

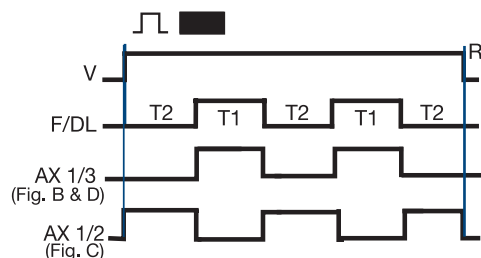

V = Voltage L = Load T1 = ON Time
T2 = OFF Time R = Reset
T1 ≅ T2

Appendix B - Dimensional Drawings

FIGURE 1

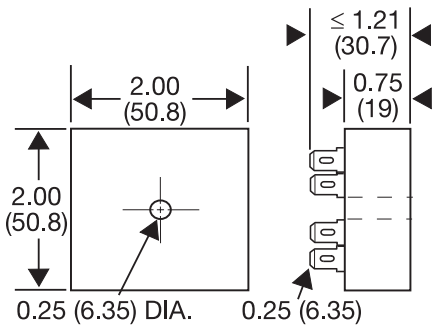

0.25 (6.35) DIA. 0.25 (6.35)

CT; ESD5; ESDR; FS100; FS200; FS300; KR3; KR9;
KRDB; KRDI; KRDM; KRDR; KRDS; KRPD; KRPS;
KSD1; KSD2; KSD3; KSD4; KSDB; KSDR; KSDS;
KSDU; KSPD; KSPS; KSPU; KVM; T2D; TA; TAC1;
TAC4; TDU; TDUB; TDUI; TDUS; TL; TMV8000;
TS1; TS2; TS4; TS6; TSB; TSD1; TSD2; TSD3; TSD4;
TSD6; TSD7; TSDB; TSDR; TSDS; TSS; TSU2000

FIGURE 2

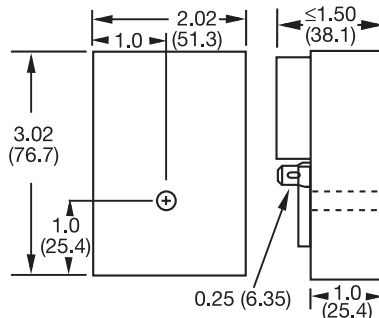

HLV; HRD3; HRD9; HRDB; HRDI;
HRDM; HRDR; HRDS; HRID; HRIS;
HRIU; HRPD; HRPS; HRPV; HRV; RS

FIGURE 3

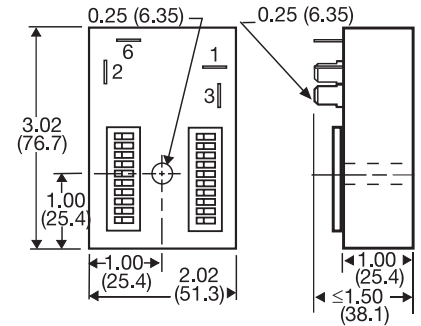

HSPZ

FIGURE 4

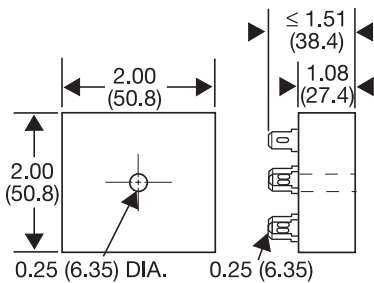

FA; FS; FSU1000*; NHPD; NHPS; NHPV;
NLF1*; NLF2*; PHS*; PTHF*; SIR1; SIR2;
SLR1*; SLR2*; TH1; TH2; THC; THD1;
THD2; THD3; THD4; THD7; THDB; THDM;
THDS; THS

*If unit is rated @ 1A, see Figure 1

FIGURE 5

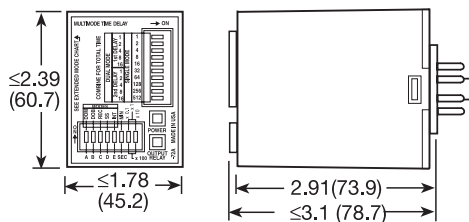

TRDU

FIGURE 6

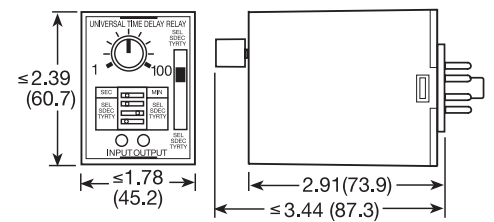

TRU

FIGURE 7

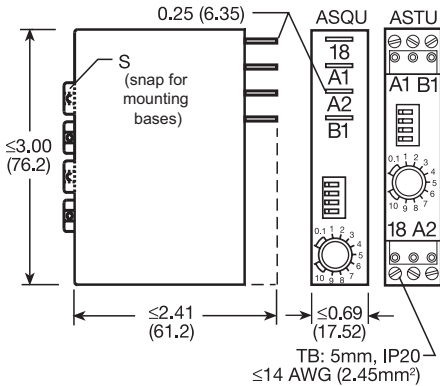

ASQU; ASTU; DSQU; DSTU

TB: 5mm, IP20
 ≤ 14 AWG (2.45mm²)

FIGURE 8

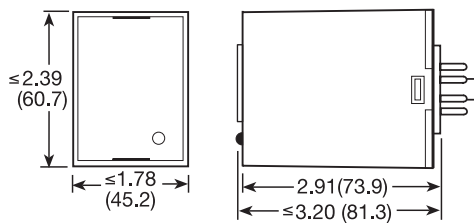

PLM; PLR; TDB; TDBH; TDBL; TDI; TDIH;
TDIL; TDM; TDMB; TDMH; TDML; TDR;
TDS; TDSH; TDSL

FIGURE 9

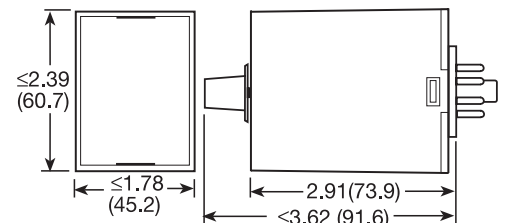

FS500; PRLB; PRM; PRLS; TRB; TRM; TRS

FIGURE 10

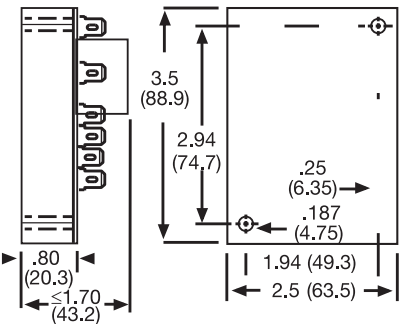

ERD3; ERDI; ERDM

FIGURE 11

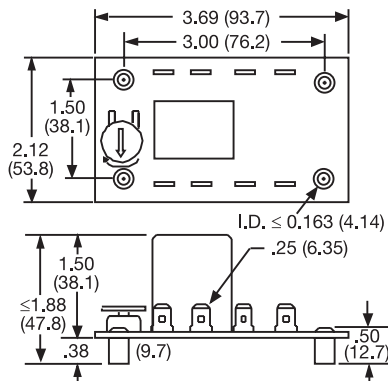

ORB; ORM; ORS

FIGURE 12

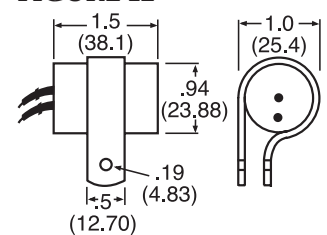

FS100; FS400

inches (millimeters)

Appendix C - Connection Diagrams

FIGURE 1 - FSU1000 Series

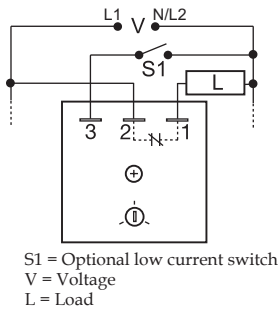

FIGURE 2 - FS100 Series

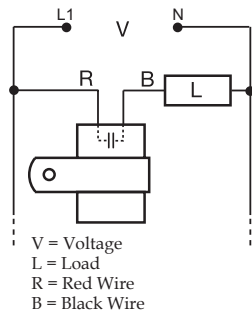

FIGURE 3 - FS100 Series

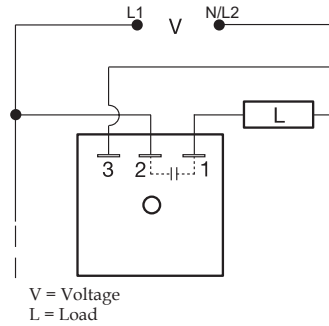

FIGURE 4 - FS200 Series

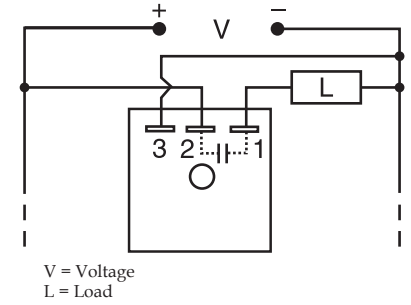

FIGURE 5 - FS300 Series

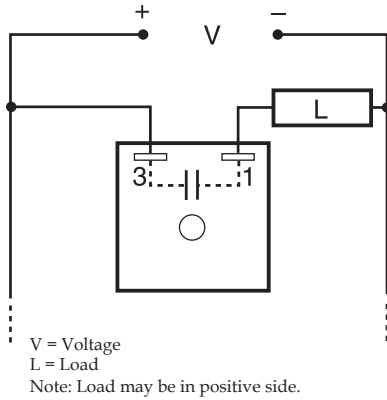

FIGURE 6 - FS400 Series

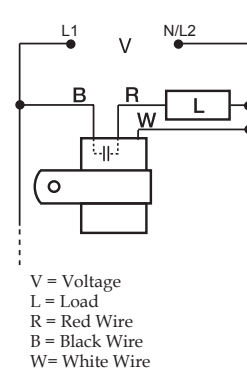

FIGURE 7 - AF Series

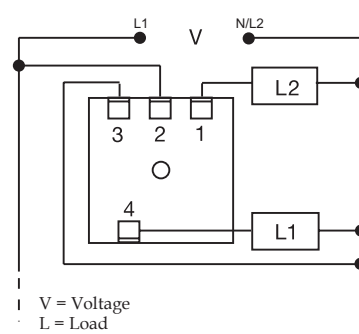

FIGURE 8 - FS500 Series

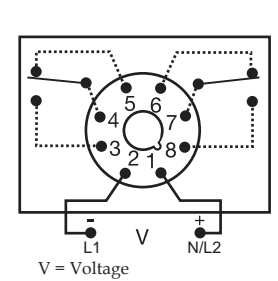

FIGURE 9 - SC3/SC4 Series

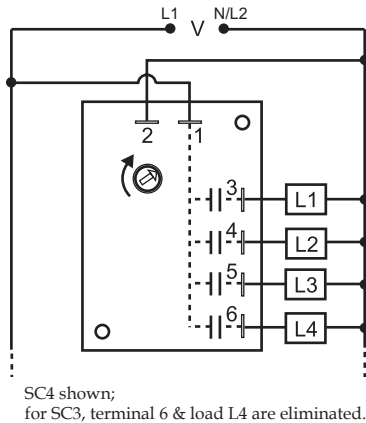

FIGURE 10 - WVM Series

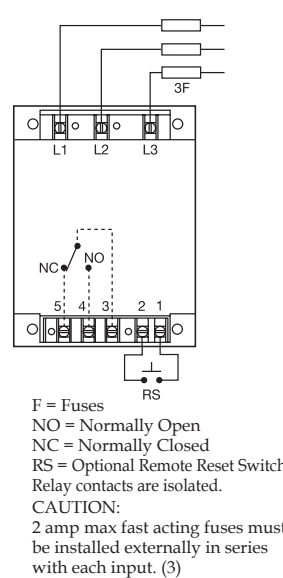

FIGURE 11 - DLMU Series

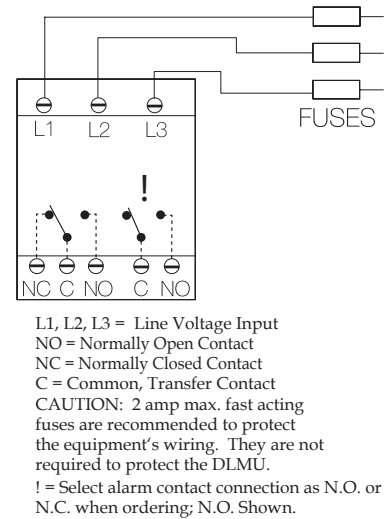

FIGURE 12 - HLMU Series

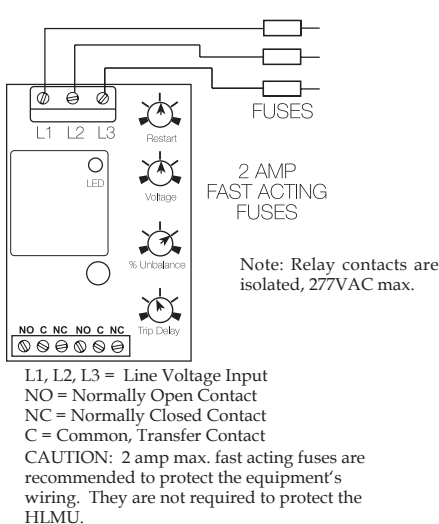

FIGURE 13 - PLMU/PLM/PLR/PLS Series

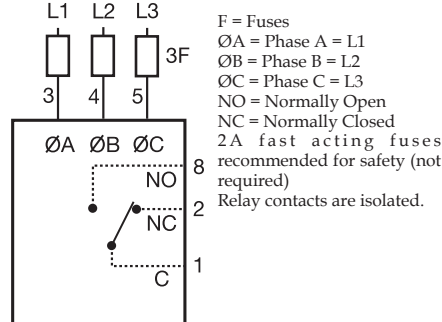

FIGURE 14 - TVM/TVW Series

