

The PLR Series provides a cost effective means of preventing 3-phase motor startup during adverse voltage conditions. Proper A-B-C sequence must occur in order for the PLR's output contacts to energize. In addition, the relay will not energize when an undervoltage or phase loss condition is present. The PLR protects a motor against undervoltage operation. The adjustment knob sets the undervoltage trip point.

For more information see:  
 Appendix B, page 165, Figure 8 for dimensional drawing.  
 Appendix C, page 168, Figure 13 for connection diagram.

## Operation

The output relay is energized and the LED glows when all voltages are acceptable and the phase sequence is correct. Undervoltage must be sensed for a continuous dropout delay period before the relay de-energizes. Reset is automatic upon correction of the fault condition. The output relay will not energize if a fault condition is sensed as power is applied.

**Field Adjustment:** Turn the adjustment knob fully counterclockwise and apply three-phase power. The LED should be ON. Increase adjustment until the LED goes OFF. Decrease adjustment until LED glows again. If nuisance tripping occurs, decrease the adjustment slightly.

**NOTE:** When properly adjusted and operating in an average system, a voltage unbalance of 10% or more is required for phase loss detection. When a phase is lost while the motor is running, a voltage will be induced into the open phase nearly equal in magnitude to the normal phase-to-phase voltage. This condition is known as regeneration. When regenerated voltages are present, the voltage unbalance during single phasing may not exceed 10% for some motors. The PLR Series may not provide protection under this condition. For systems that require superior phase loss protection, select the PLMU Series.

## Order Table:

| Voltage    | Part Number |
|------------|-------------|
| 95-140VAC  | PLR120A     |
| 190-270VAC | PLR240A     |
| 340-450VAC | PLR380A     |
| 380-500VAC | PLR480A     |

## Specifications

|                       |   |                   |
|-----------------------|---|-------------------|
| Line Voltage          | 3-phase delta or wye with no connection to neutral                  |                   |
| Type                  | Undervoltage Dropout Adj Range                                      | Line Voltage Max. |
| 120VAC                | 85 to 130VAC  | 143VAC            |
| 240VAC                | 170 to 240VAC   | 270VAC            |
| 380VAC                | 310 to 410VAC   | 480VAC            |
| 480VAC                | 350 to 480VAC   | 530VAC            |
| AC Line Frequency     | 50/60Hz   |                   |
| Phase Sequence        | ABC   |                   |
| <b>Response Times</b> |   |                   |
| Pull-in               | ≤ 400ms   |                   |
| Drop-out              | ≤ 100ms   |                   |
| Hysteresis            | Pull-in/Drop-out ≅ 2%   |                   |
| <b>Output</b>         |   |                   |
| Type                  | Electromechanical relay, energized when all voltages are acceptable |                   |
| Form                  | SPDT  |                   |
| Rating                | 5A resistive @ 240VAC, 1/4 Hp @ 120VAC                              |                   |
| Maximum Voltage       | 250VAC  |                   |

|                   |                          |                             |
|-------------------|--------------------------|-----------------------------|
| <b>Protection</b> |                          |                             |
| Surge             | IEEE C62.41-1991 Level B |                             |
| Isolation Voltage | 120 & 240VAC             | ≥ 1500V RMS input to output |
|                   | 380 & 480VAC             | ≥ 2500V RMS input to output |

|                                |   |  |
|--------------------------------|---|--|
| <b>Mechanical</b>              |   |  |
| Dimensions                     | 3.2 x 2.39 x 1.78 in. (81.3 x 60.7 x 45.2 mm) |  |
| Mounting*                      | Plug-in socket                                |  |
| Termination                    | Octal 8-pin, plug-in                          |  |
| <b>Environmental</b>           |   |  |
| Operating/ Storage Temperature | 0° to 55°C / -40° to 85°C                     |  |
| Weight                         | ≅ 6 oz (170 g)                                |  |

\*CAUTION: Select an octal socket rated for 600VAC operation.

## Features:

- Protects against phase loss (on startup), phase reversal & undervoltage
- Used where moderate voltage unbalance protection is not required
- Direct replacement for most popular 3-phase monitors
- 8-pin octal base connection
- Isolated, 5A, SPDT output contacts
- AMSE A17.1 rule 210.6
- NEMA MG1 14.30, 14.35
- IEEE C62.41-1991 Level B

Approvals:   

## Auxiliary Products:

- **Panel mount kit:** P/N: BZ1
- **Octal 8-pin socket:** P/N: OT08PC
- **3-phase fuse block/disconnect:** P/N: FH3P
- **2 Amp fuse:** P/N: P0600-11
- **DIN rail:** P/N: C103PM (AI)

## Available Models:

PLR120A  
 PLR240A  
 PLR380A  
 PLR480A

If desired part number is not listed, please call us to see if it is technically possible to build.

# Appendix B - Dimensional Drawings

**FIGURE 1**

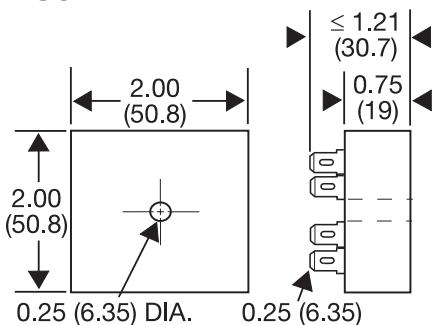

0.25 (6.35) DIA. 0.25 (6.35)

CT; ESD5; ESDR; FS100; FS200; FS300; KR3; KR9; KRDB; KRDI; KRDM; KRDR; KRDS; KRPD; KRPS; KSD1; KSD2; KSD3; KSD4; KSDB; KSDR; KSDS; KSDU; KSPD; KSPS; KSPU; KVM; T2D; TA; TAC1; TAC4; TDU; TDUB; TDUI; TDUS; TL; TMV8000; TS1; TS2; TS4; TS6; TSB; TSD1; TSD2; TSD3; TSD4; TSD6; TSD7; TSDB; TSDR; TSDS; TSS; TSU2000

**FIGURE 2**

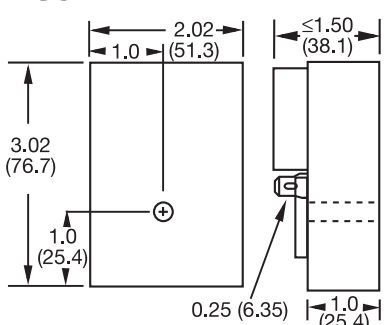

HLV; HRD3; HRD9; HRDB; HRDI; HRDM; HRDR; HRDS; HRID; HRIS; HRIU; HRPD; HRPS; HRPV; HRV; RS

**FIGURE 3**

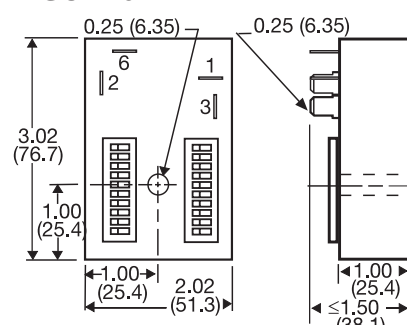

HSPZ

**FIGURE 4**

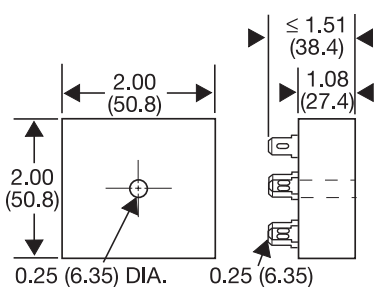

0.25 (6.35) DIA. 0.25 (6.35)

FA; FS; FSU1000\*; NHPD; NHPS; NHPV; NLF1\*; NLF2\*; PHS\*; PTHF\*; SIR1; SIR2; SLR1\*; SLR2\*; TH1; TH2; THC; THD1; THD2; THD3; THD4; THD7; THDB; THDM; THDS; THS

\*If unit is rated @ 1A, see Figure 1

**FIGURE 5**

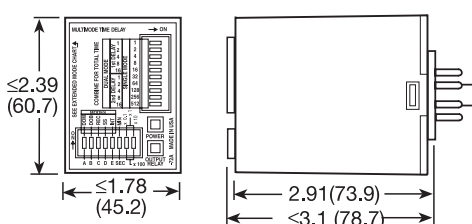

TRDU

**FIGURE 6**

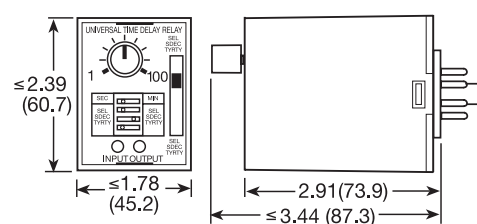

TRU

**FIGURE 7**

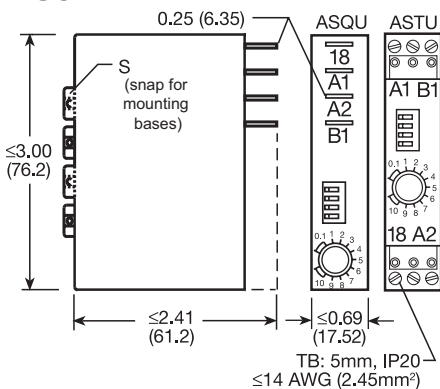

ASQU; ASTU; DSQU; DSTU

**FIGURE 8**

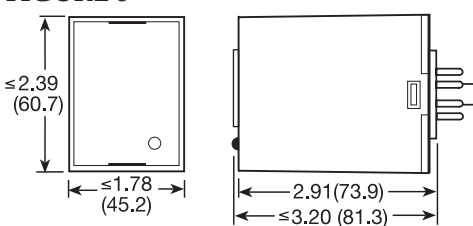

PLM; PLR; TDB; TDBH; TDBL; TDI; TDIH; TDIL; TDM; TDMB; TDMH; TDML; TDR; TDS; TDSH; TDSL

**FIGURE 9**

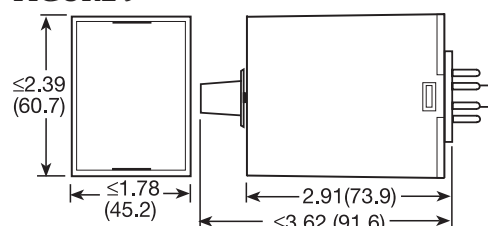

FS500; PRLB; PRM; PRLS; TRB; TRM; TRS

**FIGURE 10**

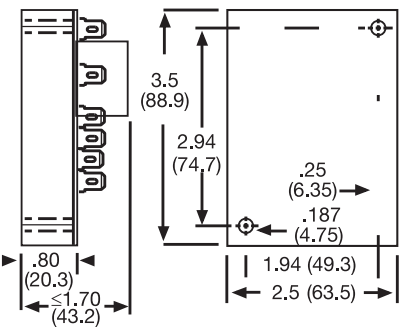

ERD3; ERDI; ERDM

**FIGURE 11**

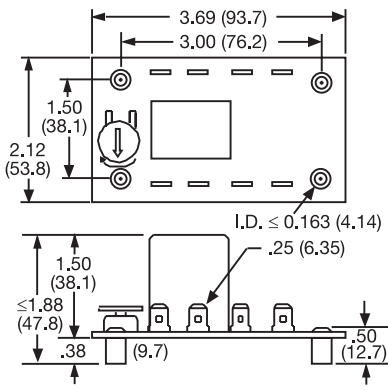

ORB; ORM; ORS

**FIGURE 12**

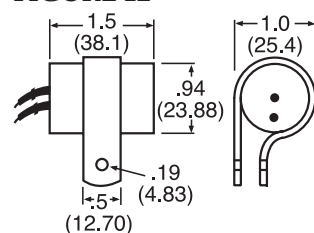

FS100; FS400

inches (millimeters)

# Appendix C - Connection Diagrams

**FIGURE 1 - FSU1000 Series**

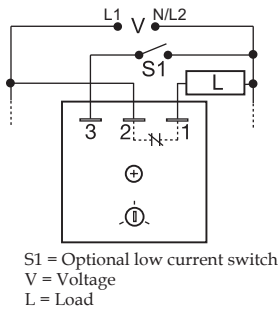

**FIGURE 2 - FS100 Series**

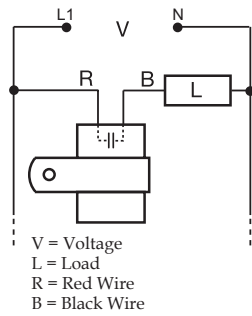

**FIGURE 3 - FS100 Series**

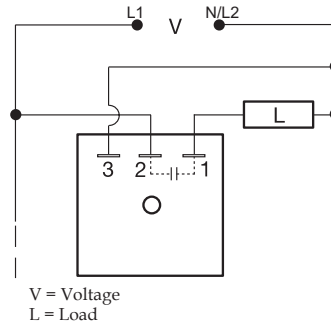

**FIGURE 4 - FS200 Series**

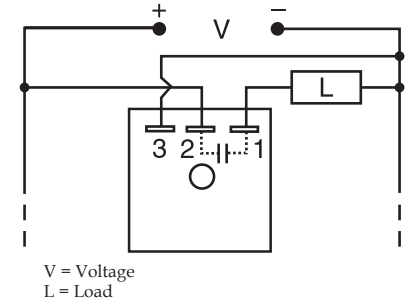

**FIGURE 5 - FS300 Series**

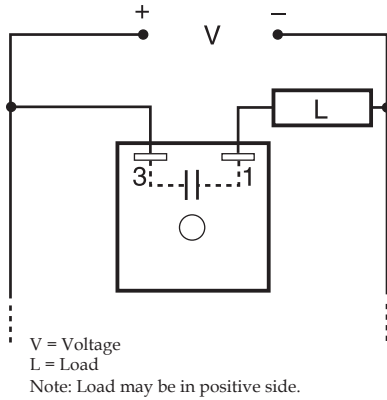

**FIGURE 6 - FS400 Series**

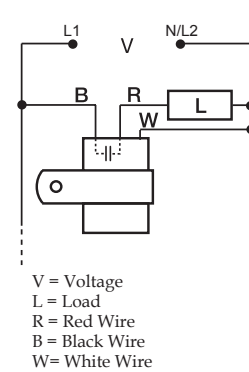

**FIGURE 7 - AF Series**

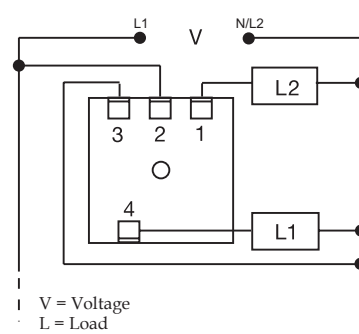

**FIGURE 8 - FS500 Series**

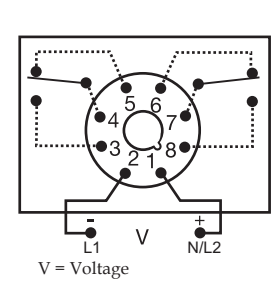

**FIGURE 11 - DLMU Series**

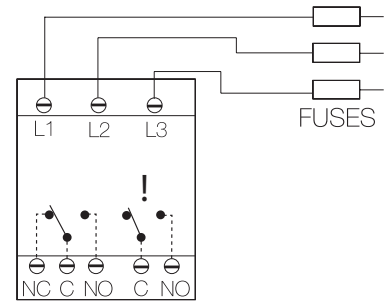

**FIGURE 9 - SC3/SC4 Series**

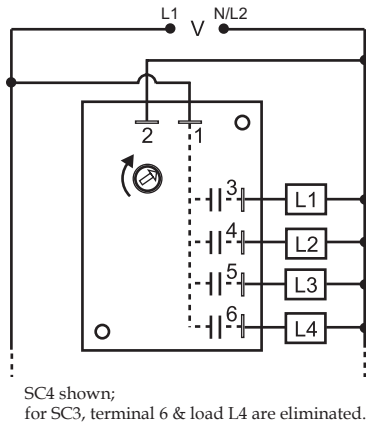

**FIGURE 10 - WVM Series**

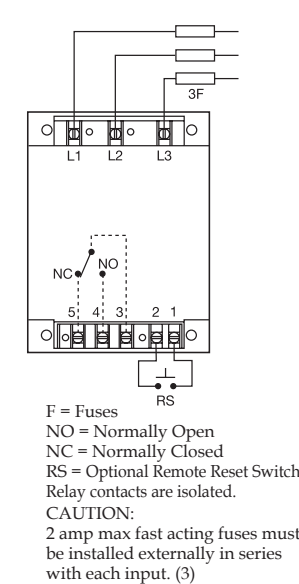

**FIGURE 12 - HLMU Series**

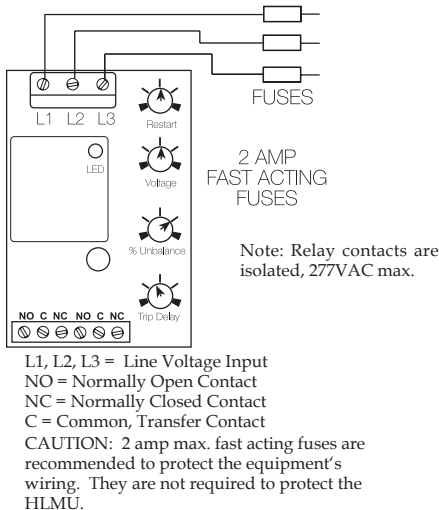

**FIGURE 13 - PLMU/PLM/PLR/PLS Series**

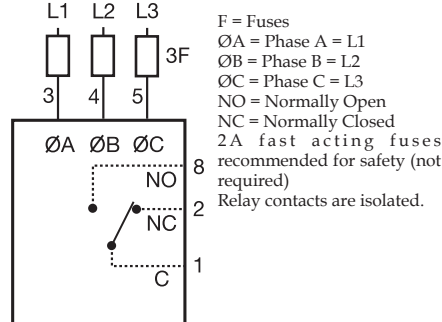

**FIGURE 14 - TVM/TVW Series**

