

Voltage Transducer CV 3-1000

For the electronic measurement of voltages: DC, AC, pulsed..., with galvanic isolation between the primary circuit (high voltage) and the secondary circuit (electronic circuit).

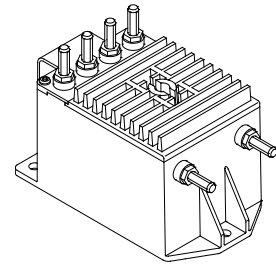

$$V_{PN} = 700 \text{ V}$$



Electrical data

V_{PN}	Primary nominal voltage rms	700	V
V_{PM}	Primary voltage, measuring range	0 .. ± 1000	V
V_S	(Analog) secondary voltage @ $V_{P \max}$	10	V
K_N	Conversion ratio	1000 V : 10 V	
R_L	Load resistance	≥ 1	k Ω
C_L	Capacitive loading	≤ 5	nF
V_C	Supply voltage ($\pm 5\%$)	± 15	V
I_C	Current consumption	$32 + V_S / R_L$	mA

Accuracy - Dynamic performance data

X_G	Overall accuracy @ $V_{P \max}$	$T_A = 25^\circ\text{C}$ - 40°C .. + 85°C	Max ± 0.2	%
V_O	Offset voltage @ $V_p = 0$	$T_A = 25^\circ\text{C}$ - 40°C .. + 85°C	± 0.6 ± 5 ± 13	% mV mV
t_r	Response time ¹⁾ to 90 % of V_{PN} step		0.3	μs
dv/dt	dv/dt accurately followed		800	V/ μs
BW	Frequency bandwidth (- 1 dB) @ 50 % of V_{PN}		DC .. 500	kHz

General data

T_A	Ambient operating temperature	- 40 .. + 85	$^\circ\text{C}$
T_S	Ambient storage temperature	- 45 .. + 90	$^\circ\text{C}$
P	Total primary power loss	3.1	W
R_1	Primary resistance	160	k Ω
m	Mass	560	g
	Standards	EN 50155: 1995	

Note: ¹⁾With a dv/dt of 800 V/ μs .

Features

- Closed loop (compensated) voltage transducer
- Isolated plastic case recognized according to UL 94-V0.

Advantages

- Excellent accuracy
- Very good linearity
- Low thermal drift
- Low response time
- High bandwidth
- High immunity to external interference
- Low disturbance in common mode.

Applications

- Single or three phases inverter
- Propulsion and braking chopper
- Propulsion converter
- Auxiliary converter
- Battery charger.

Application Domain

- Traction.

Voltage transducer CV 3-1000

Isolation characteristics

V_d	Rms voltage for AC isolation test, 50/60 Hz, 1 min	6	kV
V_e	Partial discharge extinction voltage rms @ 10pC	2	kV
dCp	Creepage distance	83.80	mm
dCl	Clearance distance	76.40	mm
CTI	Comparative Tracking Index (group I)	600	

Safety



This transducer must be used in electric/electronic equipment with respect to applicable standards and safety requirements in accordance with the manufacturer's operating instructions.



Caution, risk of electrical shock

When operating the transducer, certain parts of the module can carry hazardous voltage (eg. primary busbar, power supply).

Ignoring this warning can lead to injury and/or cause serious damage.

This transducer is a build-in device, whose conducting parts must be inaccessible after installation.

A protective housing or additional shield could be used.

Main supply must be able to be disconnected.

Dimensions CV 3-1000 (in mm. 1 mm = 0.0394 inch)

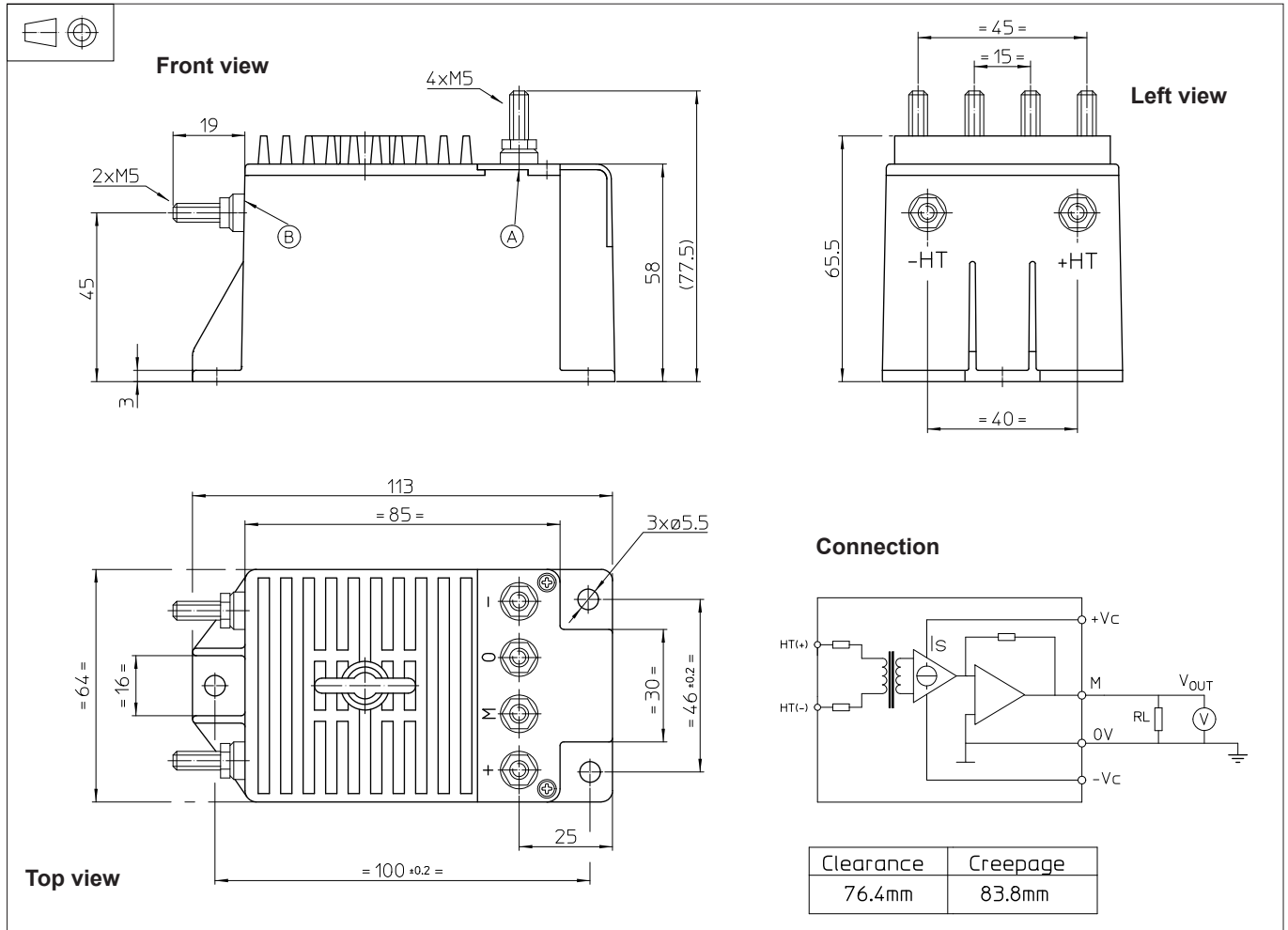

Mechanical characteristics

- General tolerance ± 0.3 mm
- Transducer fastening
 - 3 holes $\varnothing 5.5$ mm
 - 3 M5 steel screws
 - Recommended fastening torque 3.8 Nm or 2.80 Lb.-Ft.
- Connection of primary 2 M5 threaded studs
- Connection of secondary 4 M5 threaded studs
- Recommended fastening torque 2.2 Nm or 1.62 Lb.-Ft.

Remarks

- V_s is positive when V_p is applied on terminal +HT.
- CEM tested with a shielded secondary cable, shield connected to 0 V at both ends, or disconnected.
- This is a standard model. For different versions (supply voltages, turns ratios, unidirectional measurements...), please contact us.