

DIODE MODULE (F.R.D.)

FRS300CA50

UL;E76102(M)

FRS300CA50 is a high speed (fast recovery) isolated diode module designed for high power switching application. FRS300CA50 is suitable for high frequency application requiring low loss and high speed control.

- High Speed $t_{rr} \leq 200\text{ns}$
- $I_F (AV)$ 300A
- Isolated Mounting base.
- High Surge Capability

(Applications)

- Inverter Welding Power Supply
- Power Supply for Telecommunication
- Various Switching Power Supply.

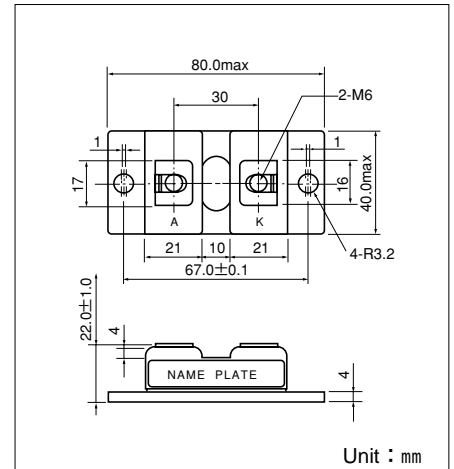
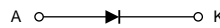

Maximum Ratings

($T_j=25^\circ\text{C}$ unless otherwise specified)

Symbol	Item	Ratings		Unit
		FRS300CA50		
V_{RRM}	Repetitive Peak Reverse Voltage	500		V
$V_{R(DC)}$	D.C. Reverse Voltage	400		V

Symbol	Item	Conditions	Ratings	Unit
$I_F (AV)$	Forward Current	D.C., $T_c : 116^\circ\text{C}$	300	A
I_{FMS}	Surge Forward Current	$1/2$ cycle, 60Hz, peak value, non-repetitive	4000	A
I^2t	I^2t	Value for one cycle of surge current	66600	A^2S
T_j	Operating Junction Temperature		-40 to +150	$^\circ\text{C}$
T_{stg}	Storage Temperature		-40 to +125	$^\circ\text{C}$
V_{iso}	Isolation Breakdown Voltage (R.M.S.)	A.C. 1 minute	2500	V
Mounting Torque	Mounting (M6)	Recommended Value 2.5-3.9 (25-40)	4.7 (48)	N·m (kgf·cm)
	Terminal (M6)	Recommended Value 2.5-3.9 (25-40)	4.7 (48)	
	Mass	Typical Value	170	g

Electrical Characteristics

Symbol	Item	Conditions	Ratings			Unit
			Min.	Typ.	Max.	
I_{RRM}	Repetitive Peak Reverse Current	$V_{RRM}=500\text{V}$, $T_j=125^\circ\text{C}$			300	mA
V_{FM}	Forward Voltage Drop	$I_F=300\text{A}$, Inst. measurement			1.3	V
t_{rr}	Reverse Recovery Time	$I_F=300\text{A}$, $-di/dt=300\text{A}/\mu\text{s}$			200	ns
$R_{th(j-c)}$	Thermal Impedance	Junction to case			0.085	$^\circ\text{C}/\text{W}$

