

OA172SAPL Series

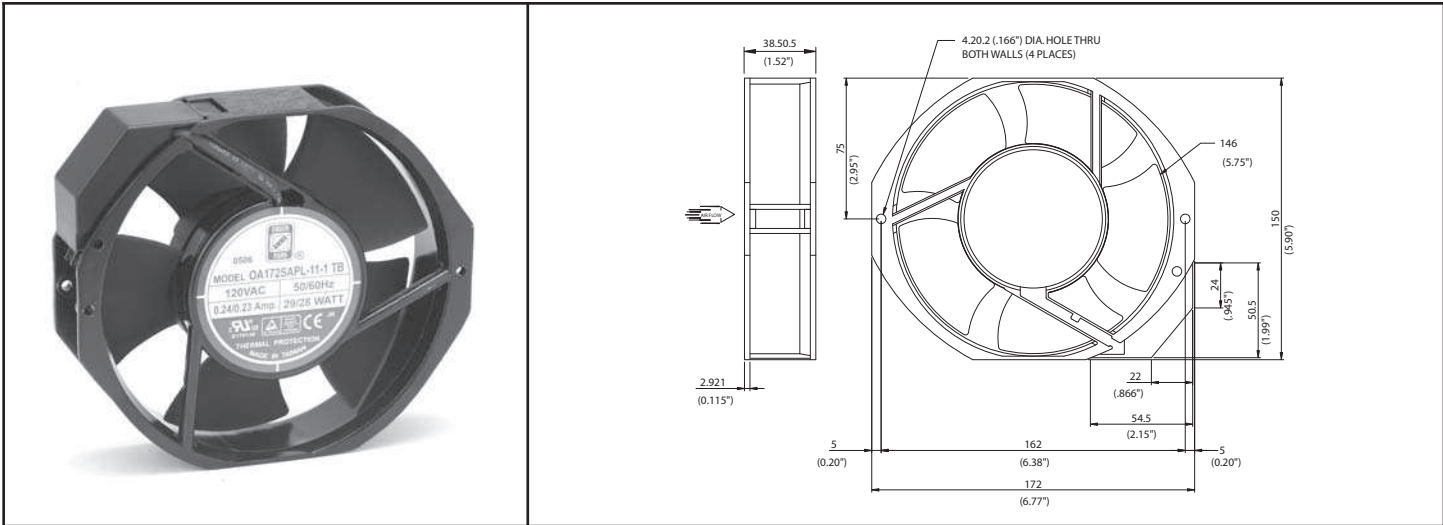

172 x 150 x 38mm
(6.7"x 5.9"x 1.5")



Frame	Diecast Aluminum	<p><u>Operating Temperature</u> Ball Bearing -20C ~ +80C</p> <p><u>Life Expectancy</u> Ball Bearing 60,000 hours (L10 at 40C)</p>	
Impeller	PBT, UL94V-O plastic		
Connection	2x Lead Wires or Terminals		
Motor	Capacitor drive, thermally protected		
Bearing System	Dual ball		
Insulation Resistance	>100M ohm between lead-wire and frame (500VDC)		
Dielectric Strength	1 min at 1500 VAC, 50/60Hz		

Model Number	Speed (RPM)	Airflow (CFM)	Noise (dB)	Volts AC	Voltage Range	Watts	Max. Static Pressure ("H2O)
OA172SAPL-11-1 *	3400	228	58	115	103~126	28	0.87
OA172SAPL-11-2 *	2750	162	50	115	103~126	27	0.35
OA172SAPL-11-3 *	1700	103	44	115	103~126	26	0.26
OA172SAPL-22-1 *	3400	228	58	230	160~260	28	0.87
OA172SAPL-22-3 *	1700	103	44	230	160~260	26	0.26

* Indicate "TB" (Terminal Ball Bearing), "WB" (12" Wire Leads, Ball Bearing)