

UM9980/8 November 2009

Features

- Allows full evaluation and investigation of the **CMX998 Cartesian Feedback Transmitter IC**
- Operational range: **100MHz to 1GHz**
- Access to RF, control and baseband signals via connectors and test points
- Complete demonstration of Cartesian Feedback Loop functionality: default is **450MHz** and configurable for **800MHz**
- Support and interfacing for customer PAs
- Interfaces to **CMX981 EvKit**
- Differential or single-ended I and Q inputs
- Can utilise **PE0002 EvKit interface** to work with a PC or can be used with custom interface equipment

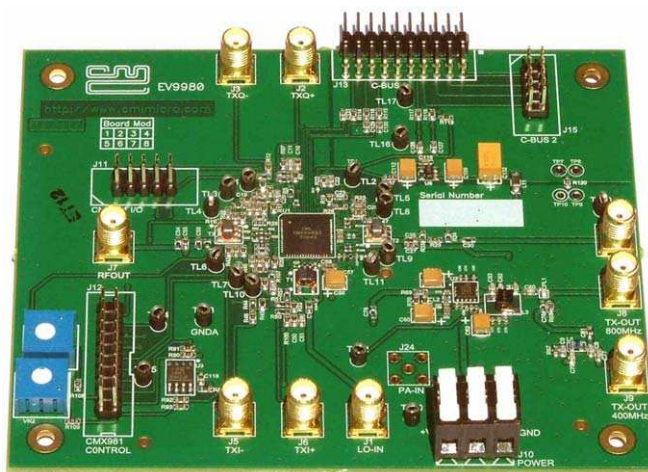

1 Brief Description

The EV9980 EvKit allows rapid and full evaluation of the CMX998 Cartesian Feedback Transmitter IC.

In the form of a populated PCB, this flexible platform enables users, using a control interface, to configure and evaluate the CMX998 to various applications and frequency bands.

Access is provided to all CMX998 RF, baseband and control signals by either connector or test points. Test access points are available to accept common test equipments such as RF and baseband signal generators and spectrum analysers.

All signal paths are matched by suitable components and the EvKit provides a power amplifier (PA) device at 450MHz which can be modified to provide operation at 800MHz. The EvKit can also be configured for an external PA. The overall operating evaluation frequency range of the EvKit is for RF frequencies between 100MHz and 1GHz.

The EV9980 can be configured to work with the CMX981 Digital Radio Baseband processor IC, standard test equipment or with a custom baseband system.

No software is required for use of the EvKit; the on-board CMX998 is controlled via its C-BUS serial interface and control system. This can be controlled by a PE0002 interface card (available separately) or, alternatively, a custom C-BUS interface and control system can be used.

CONTENTS

<u>Section</u>	<u>Page</u>
1	Brief Description 1
1.1	History 4
2	Preliminary Information 6
2.1	Laboratory Equipment 6
2.1.1	Power Supply 6
2.2	Handling Precautions 6
2.2.1	Static Protection 6
2.2.2	Contents - Unpacking 6
2.3	Approvals 7
3	Quick Start 8
3.1	Make External Connections and Apply Power 8
3.2	Configure and Trim 9
3.3	Operate 10
4	Signal Lists 11
5	Circuit Schematics and Board Layouts 15
6	Detailed Description 17
6.1	Hardware Description 17
6.1.1	Cartesian Feedback Loop (CFBL) 17
6.1.2	Power Amplifiers 17
6.1.3	Local Oscillator (LO) 18
6.1.4	I/Q Baseband Inputs 18
6.1.5	CMX981 Interface 18
6.1.6	Manual DC Nulling 18
6.1.7	Power Supply 18
6.2	Adjustments and Controls 18
6.2.1	800MHz Operation using the RF2173 19
6.2.2	850MHz Operation using RF5110G 19
6.2.3	Improved Wideband Noise in 450MHz Operation 21
6.2.4	Using an External Power Amplifier 21
6.3	Software Description 22
6.3.1	The CMX998 Regs (\$01-\$06) Tab 22
6.3.2	The CMX998 Regs (\$07-\$08, \$F2-\$F8) Tab 23
6.3.3	The Script Handler Tab 24
6.4	Application Information 25
6.4.1	Error Configuration 25
6.4.2	Typical Performance of Closed Loop Configuration 25
6.4.3	450MHz TETRA Operation and Wideband Noise 33
6.4.4	Testing the CMX998 with the CMX981 34
6.5	Troubleshooting 39
6.5.1	Closed Loop Operation 39
6.5.2	Open Loop Operation 39
7	Performance Specification 40
7.1	Electrical Performance 40
7.1.1	Absolute Maximum Ratings 40
7.1.2	Operating Limits 40
7.1.3	Operating Characteristics 41

<u>Table</u>	<u>Page</u>
Table 1 – Signal List.....	12
Table 2 – PE0002 Interface	12
Table 3 – Test Loops	13
Table 4 – Test Points	14
Table 5 – Component changes to EV9980 for 850MHz operation with RF5110G.....	19
Table 6 – Changes to EV9980 for 850MHz closed-loop operation	20
Table 7 – EV9980 Typical wideband noise performance	33
Table 8 – EV9980 and EV9810 interconnection details	34
Table 9 – Closed Loop possible errors	39
Table 10 – Open Loop possible errors	39
<u>Figure</u>	<u>Page</u>
Figure 1 – Block Diagram	5
Figure 2 – Typical Evaluation Connections for EV9980	8
Figure 3 – PCB Layout: top.....	15
Figure 4 – PCB Layout: bottom.....	16
Figure 5 – RF5110G 850MHz, 0dBm Input Power.....	20
Figure 6 – EV9980 Configuration with an external power amplifier	21
Figure 7 – The CMX998 (\$01-\$06) Tab.....	22
Figure 8 – The CMX998 (\$07-\$08, \$F2-\$F8) Tab.....	23
Figure 9 – The Script Handler Tab	24
Figure 10 – Error Amplifier Configuration	25
Figure 11 – CMX998 and RF2175 performance at 450MHz.....	25
Figure 12 – CMX998 and RF5110G performance at 450MHz	26
Figure 13 – CMX998 and RF5110G performance at 450MHz	27
Figure 14 – CMX998 and RF2173 performance at 800MHz.....	28
Figure 15 – CMX998 and RF2173 performance at 800MHz.....	28
Figure 16 – CMX998 and RF2173 performance at 800MHz.....	29
Figure 17 – CMX998 and RF2173 performance at 800MHz.....	29
Figure 18 – Broadband (1MHz) plot of CMX998 and RF2173 performance at 800MHz	30
Figure 19 – RF5110G Closed Loop Operation at 850MHz	31
Figure 20 - Two-tone linearization improvement	31
Figure 21 – Wideband (1MHz) plot of linearised two-tone signal.....	32
Figure 22 - Wideband response at extreme loop phase settings	32
Figure 23 – TETRA adjacent channel power measurement.....	34
Figure 24 – CMX998 Input Amplifier Configuration	35
Figure 25 – CMX998 Configuration for testing with CMX981	36
Figure 26 – 1 st and 2 nd ACP Performance	36
Figure 27 – Open and closed loop performance comparison	37
Figure 28 – Trellis Diagram.....	37
Figure 29 – Constellation Diagram	38
Figure 30 – Symbol/Error Table.....	38

It is always recommended that you check for the latest product datasheet version from the Datasheets page of the CML website: [www.cmlmicro.com].

1.1 History

Version	Changes	Date
8	<ul style="list-style-type: none"> References changed from two PAs to a single PA, as only one is fitted. Block Diagram (Figure 1) modified, to show which blocks are not fitted in the kit. Component values for T3 added. Component values in Table 5 and section 6.2.3 updated Input Amplifier Configuration (Figure 24) updated with component references and component changes list (below) also updated Minor typographical changes and style updates 	17/11/09
7	<ul style="list-style-type: none"> Updated to include reference to using PE0002 instead of PE0001. Removed the definition of "Mod State" and associated list of modifications, which are only applicable to earlier pcb revisions. Section 7.1.3; the LO input drive level range was incorrect. 	13/11/08
6	<ul style="list-style-type: none"> This version applies to PCB555D 'Mod States' 2, 3, 4 and 5. Mod states are updated to reflect that RF2173 (U2) is now optional (section 5) PA description in section 6.1.2 now states U2 (RF2173) is not fitted as standard and notes that the RF5110G can be used at ~800MHz. Section 6.2.1 is now specific to RF2173, noting that this device needs to be fitted for PCBs of 'Mod state' 4 and 5. New section 6.2.2 added concerning RF5110G at 850MHz, subsequent sections re-numbered. Section 6.4.2 separated into sub-sections for each PA configuration. Figure 12, Figure 13 formatting corrected. Results from RF5110G at 850MHz added in 6.4.2.3. Section 6.4.3: text formatting corrected. V_{PA} absolute maximum voltage increased to 6.0V and normal operating voltage to 4.8V - in line with RFMD limits for RF5110G and RF2173. (Sections 6.1.7, 7.1.1, 7.1.2 and 3.1) Correct TL referenced for RF5110G PA (TL20 not TL13) in section 6.5.1 Nominal V_{PA} increased to 3.7V (Section 7.1.3) 	16/7/08
5	<ul style="list-style-type: none"> Extensive changes. This version applies to PCB555D 'Mod States' 2 and 3 only 	25/6/08
4	<ul style="list-style-type: none"> Not issued 	
3	<ul style="list-style-type: none"> Applies to PCB555C ('Mod State' 1) and PCB555B ('Mod State' 1 or 2). 	20/11/06

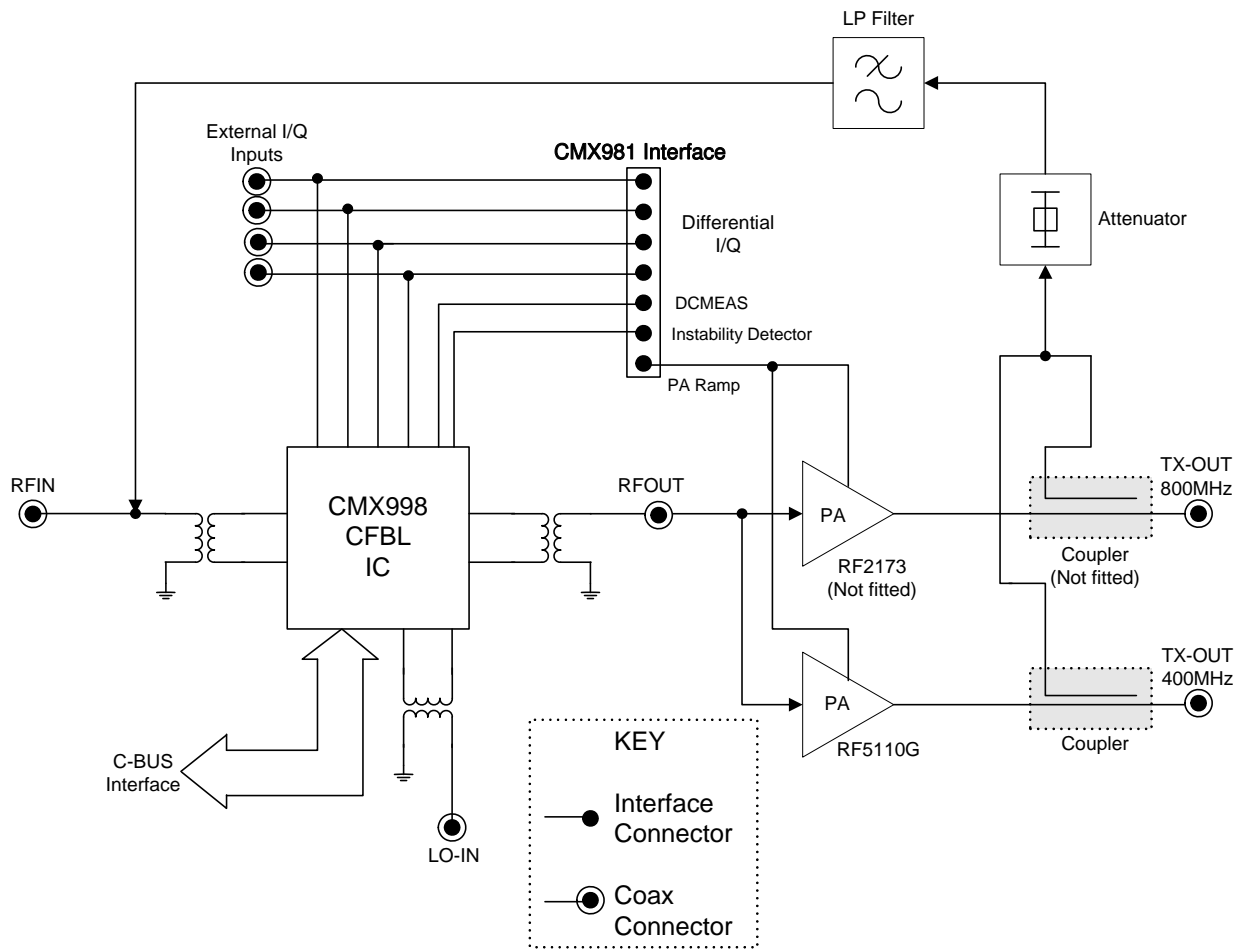

Figure 1 – Block Diagram

2 Preliminary Information

The EV9980 provides a platform for the evaluation of the CMX998. To use the EV9980, a separate micro-controller or PC, for example, is required to program the CMX998 via its C-BUS interface. This controlling device is not included on the EV9980 but there is a CML product available to provide the controlling functionality: the PE0002 with EV9980 PC software (ES9980xx.exe).

2.1 Laboratory Equipment

The following laboratory equipment is needed to use this evaluation kit:

- Dual Power Supply (Triple Power Supply if using PE0002).
- Spectrum Analyzer (100MHz to 1GHz)
- RF Attenuator
- RF Signal Generator (100MHz to 2GHz)
- I/Q Signal Source

For more detailed design or investigation work the customer may require other RF test equipment.

2.1.1 Power Supply

The supply input voltage to the PCB, for all circuits except the PA, is 7.2V (5.25V to 8V acceptable). On board regulators are provided to generate all voltage rails used on the PCB (3.3V and 5V rails are used).

The supply to the PA is directly connected to the PA: a voltage of 3.6V, at the PA, is recommended. (See also section 6.5.1)

The 7.2V supply should be rated at 1A and the 3.6V supply rated at 2A.

NOTE: Care should be exercised with the supplies, as they are not protected for reverse polarity. For optimum RF performance, the PA supply is connected directly to the RF2173 and RF5110G device so care is required to ensure the RF2173 and RF5110G manufacturer's ratings are not exceeded.

NOTE: When using the EV9980 kit with a PE0002 kit, power is not supplied to the PE0002 via the C-BUS connector (J13). The PE0002 must be connected directly to a separate 5.0V dc regulated power supply.

2.2 Handling Precautions

Like most evaluation kits, this product is designed for use in office and laboratory environments. The following practices will help ensure its proper operation.

2.2.1 Static Protection

This product uses low power CMOS circuits that can be damaged by electrostatic discharge. Partially damaged circuits can function erroneously, leading to misleading results. Observe ESD precautions at all times when handling this product.

2.2.2 Contents - Unpacking

Please ensure that you have received all of the items on the separate information sheet (EK9980) and notify CML within 7 working days if the delivery is incomplete.

2.3 Approvals

This product is not approved to any EMC or other regulatory standard. Users are advised to observe local statutory requirements, which may apply to this product and the radio frequency signals that may emanate from it.

3 Quick Start

This section provides instructions, in three main steps, for users who wish to experiment immediately with the evaluation kit at 450MHz, which frequency is the kit's default hardware configuration. A more complete description of the kit and its use appears later in this document. The EV9980 includes a CMX998 device that is described in its own, separate, datasheet.

Accordingly, before using the EV9980 the user should read the current CMX998 datasheet.

3.1 Make External Connections and Apply Power

In this first main step external connections are made to the EV9980 and then power is applied. Perform the following steps in sequence:

1. **Connect the power amplifier output (J9) to a suitable 50Ω load.** The default frequency of operation for the EV9980 is 450MHz.
Failure to connect and use a suitable external 50Ω load may damage the PA stage.
2. Connect test leads as shown below in Figure 2.
3. Connect a host μ Controller to C-BUS interface J13 or J15 (alternatively the CML PE0002 card and ES9980xx.exe software can be used – see section 6.3).
4. A connection should be made to J12 pin 15 to allow the PA control volts to be adjusted.
5. Power should be applied to the main supply (7.2V nominal).
6. Power should be applied to the power amplifier supply connector (circa 3.6V to 3.8V).

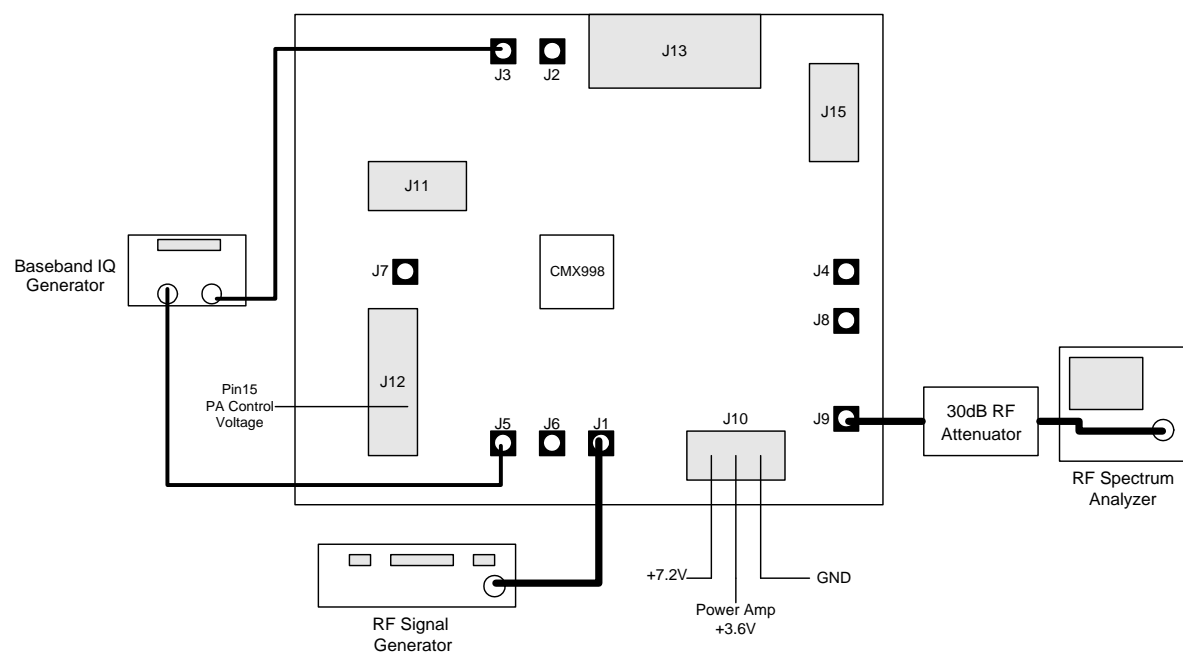

Figure 2 – Typical Evaluation Connections for EV9980

3.2 Configure and Trim

In this second step the EV9980 is configured and then trimmed while operating it with 0V dc on I/Q baseband input signals.

Perform the following three steps in sequence:

1. Set the applied signals and or register value per the following table. (Setting CMX998 registers requires the use of the host connected per section 3.1 step 3, above. The CMX998 datasheet gives details of the registers and commands).

Signal or Register	Setting	Connector	Note
LO input	900MHz at -10 dBm	J1	This frequency is twice the RF output frequency that will be developed
I/Q baseband inputs	0V dc	J3, J5	These inputs must be connected to 0V dc; do not leave them unconnected or open circuit
CMX998 General Control register (\$02)	Set CMX998 General Control register bits 0 and 1 to their normal operation state (set both to '0') and enable all of: <ul style="list-style-type: none"> • Forward path • Feedback path • Bias circuits • Filter amplifiers • Input amplifiers • Error amplifiers 		
Phase Control register (\$03)	315 degrees		This is a typical setting for 450MHz
Forward Path Gain Control register (\$05)	0 dB		
Feedback Path Gain Control register (\$06)	17 dB		
Frequency Control register (\$08)	Divide by 2 mode (b4 cleared to '0')		This means the externally applied LO must be twice the desired RF carrier frequency
Auxiliary Control register (\$07)	Leave all bits cleared to '0'		
PA_CNTRL	Apply 1.2V dc to this PA control input	Pin 15 of J12	This provides nominal PA output power

2. Analyse the RF PA output to ensure the loop phase has been correctly set.
3. Adjust VR1 and VR2 to minimise the RF PA output carrier level. (This step reduces dc signal path errors by adjusting EAQP and EAIP input offsets, respectively).

3.3 Operate

Baseband I/Q signals (typically 1.6V p-p to 2.0V p-p) can now be applied to develop a linearised, modulated RF output of >+32 dBm PEP.

Notes:

- a) The output of the CMX998's input amplifiers should be 0.8V p-p nominal and 1.0V p-p maximum. Any user changes to the input amplifier's external components and applied baseband I/Q signal levels should ensure the amplifiers' output level remains at 0.8V p-p nominal and 1.0V p-p maximum.
- b) The peak to average power ratio of the user-provided modulation will determine the mean RF output power delivered by the EV9980. This is true for any RF PA.
- c) Applying low I/Q baseband input signal levels will needlessly raise the noise floor of the RF PA output and so should be avoided.

4 Signal Lists

CONNECTOR PINOUT				
Connector Ref.	Connector Pin No.	Signal Name	Signal Type	Description
J1	N/A	LO-IN	RF	LO input can be applied at 2 x RF output frequency or 4 x RF output frequency. Nominal input level is -10dBm.
J2	N/A	TXQ+	Baseband	Q input signal (non-inverting input of input amplifier)
J3	N/A	TXQ-	Baseband	Q input signal (inverting input of input amplifier)
J4	N/A	RFIN	RF	RF input to feedback path
J5	N/A	TXI-	Baseband	I input signal (inverting input of input amplifier)
J6	N/A	TXI+	Baseband	I input signal (non-inverting input of input amplifier)
J7	N/A	RFOUT	RF	Upconverter RF output
J8	N/A	TX-OUT 800MHz	RF	800MHz PA output (800MHz PA not fitted)
J9	N/A	TX-OUT 400MHz	RF	450MHz PA output
J10	3	+7.2V	DC	7.2V power supply input
J10	2	+3.6V	DC	3.6V power supply for RF power amplifier
J10	1	GND	DC	Power supply ground
J11	1, 3, 7, 9	TXQ+, TXQ- TXI-, TXI+	Baseband	Differential I/Q input from the CMX981 evaluation board
J11	2, 4, 5, 6, 8, 10	GNDA	Baseband	Connection to Analogue Ground
J12	1	INSTAB	Baseband	Instability detector output to CMX981 connector
J12	3	DCMEAS	Baseband	DCMEAS output to CMX981 connector
J12	5	FW_Q	Baseband	Forward path baseband Q signal to CMX981 connector
J12	7	FB_Q	Baseband	Feedback path baseband Q signal to CMX981 connector
J12	9	FB_I	Baseband	Feedback path baseband I signal to CMX981 connector
J12	11	FW_I	Baseband	Forward path baseband I signal to CMX981 connector
J12	15	PA_CNTRL	DC	PA control voltage external or from CMX981 evaluation board

CONNECTOR PINOUT				
Connector Ref.	Connector Pin No.	Signal Name	Signal Type	Description
J13	1 - 20	C-BUS Interface	Logic	C-BUS interface from PE0002 or host / controller PC. See schematics and CMX998 datasheet for details.
J15	1 - 10	Alternative C-BUS Interface	Logic	Alternative header for C-BUS interface

Table 1 – Signal List

CONNECTOR PINOUT for J13			
Connector Pin No.	Signal Name	Signal Type	Description
1	RESET	I/P	General RESET (RESET active low)
2	CSN	I/P	C-BUS Enable
3	~	~	Spare pin. Leave unconnected
4	S_DATA_IN	I/P	C-BUS Data Input
5	~	~	Spare pin. Leave unconnected
6	S_CLOCK	I/P	C-BUS Clock
7	~	~	Spare pin. Leave unconnected
8	S_DATA_OUT	O/P	C-BUS Data Output
9	~	~	Spare pin. Leave unconnected
10	IRQN	I/P	Interrupt request - if required. Not used
11	GNDD	Power	Connection to Digital Ground
12	GNDD	Power	Connection to Digital Ground
13	~	~	Spare pin. Leave unconnected
14	~	~	Spare pin. Leave unconnected
15	~	~	Spare pin. Leave unconnected
16	~	~	Spare pin. Leave unconnected
17	~	~	Spare pin. Leave unconnected
18	~	~	Spare pin. Leave unconnected
19	~	~	Spare pin. Leave unconnected
20	~	~	Spare pin. Leave unconnected

Table 2 – PE0002 Interface

TEST LOOPS		
Test Loop Ref.	Default Measurement	Description
TL1	1.6V dc	Q Input Amplifier Output
TL2		Instability Detector Output
TL3		Q Image Filter Amplifier Output
TL4		Q Error Amplifier Output
TL5		BVREF Buffered Vref
TL6		I Error Amplifier Output
TL7		I Image Filter Amplifier Output
TL8		Demodulator Output (Q channel)
TL9		Demodulator Output (I channel)
TL10		I Input Amplifier Output
TL11		Connection point for AVdd on CMX981 evaluation board
TL12		800MHz power amplifier (U2) control voltage <i>(800MHz PA not fitted)</i>
TL13		Void
TL14		DCMEAS Output
TL15		Spare connection on J12:J13
TL16		C-BUS Data Output
TL17		IRQN (not used)
TL18		GND probe point
TL19		GND probe point
TL20		RF5110G power amplifier (U10) control voltage

Table 3 – Test Loops

TEST POINTS		
Test Point Ref.	Default Measurement	Description
TP1	3.3V	3.3V regulator output for digital circuits
TP2	3.3V	3.3V regulator output for analogue circuits
TP3	5.0V	5.0V regulator output for RF circuits
TP7	0V	Digital Ground
TP8	0V	Digital Ground
TP9	0V	Analogue Ground
TP10	0V	Analogue Ground

Table 4 – Test Points

Notes:

I/P	=	Input
O/P	=	Output
BI	=	Bidirectional
TL	=	Test Loop
TP	=	Test Point

5 Circuit Schematics and Board Layouts

For clarity, circuit schematics and board layouts are available as separate high-resolution files. These can be obtained via the CML website.

The layout on each side of the pcb is also shown in Figure 3 and Figure 4.

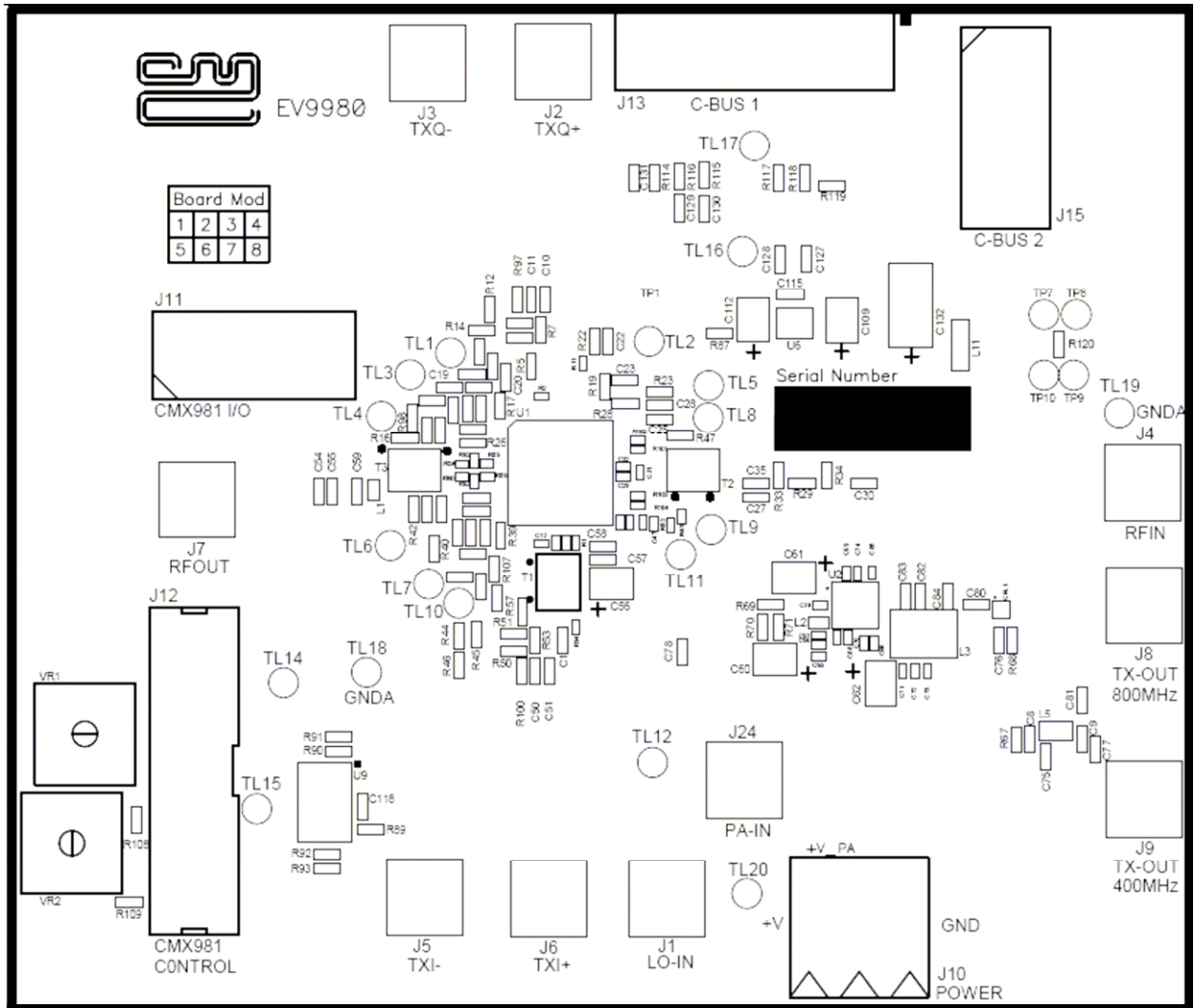

Figure 3 – PCB Layout: top

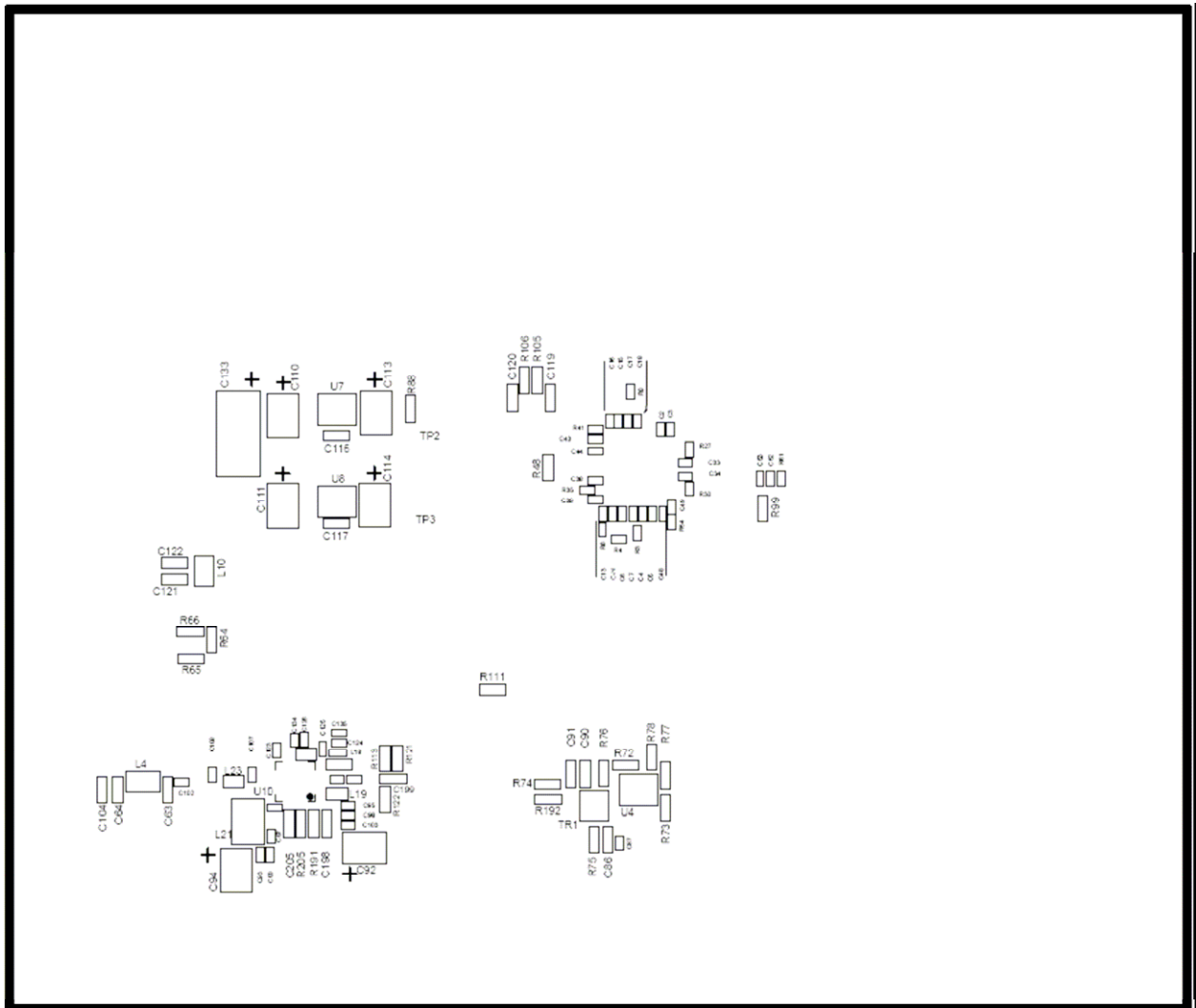

Figure 4 – PCB Layout: bottom

6 Detailed Description

The CMX998 datasheet (available at www.cmlmicro.com) should be referred to for a detailed description of the CMX998 device.

The EV9980 functionality includes:

- Demonstration of the CFBL RF functionality. One PA device has been included to allow operation at 450MHz to be evaluated in detail
- Operation at 100MHz to 1000MHz
- Support for customer power amplifiers at different powers and frequencies over the full operating range of the CFBL IC
- C-BUS Interface that allows the card to be connected to a host μ Controller. Interface to a PC for initial test and customer evaluation is available separately with suitable PC software that allows control of all device functions
- Interface directly to CMX981 evaluation card allows demonstration of:
 - $\pi/4$ -DQPSK modulation
 - burst and continuous transmission

In summary, the EV9980 allows the user to create experiments to investigate all aspects of the CMX998 device. The EV9980 is designed to allow user modification, to support detailed investigation of each user's specific and different applications.

6.1 Hardware Description

6.1.1 Cartesian Feedback Loop (CFBL)

The card is configured to allow the CFBL to operate in normal operation with single ended external inputs. The gains are set in the baseband amplifier sections to suit the input drive levels in section 6.1.4. The error amplifier is configured with a loop filter optimised for operation with the on-board power amplifier, but can be configured with user values for any other requirements. It is possible to access the up-converter output and the down-converter input so that customers can connect their own power amplifiers into the loop (section 6.2.4). The LO input and modulator output are matched with broadband balun transformers to allow wideband operation from 200MHz to 1GHz. *NOTE: EV9980 is supplied with transformer (T3) fitted with a TC4-14+ from Mini Circuits; this is recommended for applications between 200MHz and 1GHz. For operation at 100MHz to 200MHz, customers are recommended to fit an alternative component, e.g. Coilcraft WBC4-1WL.*

The RESET pin (active low) is pulled high with 100k ohms. The user can pull this pin low to reset the device (or the software reset can be used).

6.1.2 Power Amplifiers

The card includes footprints for power amplifiers to demonstrate the CFBL IC at ~450MHz or ~800MHz. The default connection uses U10 (RF5110G) configured for 450MHz operation and is capable of producing 29~30dBm (mean) output power with $\pi/4$ -DQPSK modulation. An option of using an 800MHz power amplifier (U2, RF2173) is included in the design and this is also capable of 29~30dBm (mean) output with $\pi/4$ -DQPSK modulation. U2 is not fitted to the EV9980 as supplied but can be fitted by the user. Alternatively the RF5110G can also be reconfigured for ~800MHz operation. Component changes are required to make use of either of these options, see section 6.2.1 or 6.2.2.

Gain control has been included which allows the power amplifiers to be connected to the CMX981 Ramping DAC or to an external variable voltage source.

6.1.3 Local Oscillator (LO)

The local oscillator has not been provided on the EV9980. A connector is provided to allow an external oscillator source to be injected at twice or four times the RF output frequency depending on the oscillator mode selected in the CM998 Frequency Control register.

6.1.4 I/Q Baseband Inputs

The board allows the I/Q inputs to come from the CMX981 or from an alternative external source. The input can be differential or single ended. Adjusting the values around the CMX998 input amplifiers creates the required input configuration. The default setup is for single ended inputs, which are applied to TXI- and TXQ-. A typical input signal would be ~1.6V p-p at 0V dc bias.

6.1.5 CMX981 Interface

The EV9980 has an interface to allow connection to the CMX981 Evaluation card (EV9810). There are two connectors J11 and J12 that include the following signals:

- I/Q Input signals from CMX981
- DCMEAS pin from CMX998 to CMX981 AUX ADC
- Ramping DAC signal from CMX981 to EV9980 power amplifiers
- Instability detector output
- DC Nulling signal input (optional)

6.1.6 Manual DC Nulling

The dc nulling can be done manually through the use of VR1 and VR2 variable resistors. They affect the dc level of at the input to the modulator so that the carrier can be nulled to a minimum manually. Automatic control can be implemented through the CMX981 interface (see CML Application Note 'Cartesian Feedback Loop DC Calibration').

6.1.7 Power Supply

The input to the PCB for CMX998 and interface circuits is nominally 7.2V (5.25V to 8V is acceptable). On board regulators are provided to generate voltage rails used on the EV9980 (3.3V used for CFBL IC).

The power supply to the PA is provided directly from a separate 3.6V (nominal) input. This supply can be in the range 3.6V to 3.8V to achieve +33dBm PEP output power.

6.2 Adjustments and Controls

The user has the ability to configure the EV9980 for a number of different operational scenarios.

6.2.1 800MHz Operation using the RF2173

The default operating frequency is 450MHz, so the following components need to be changed to enable the EV9980 to work at 800MHz:

- For PCBs 'Mod State' 4 or 5, U2 (RF2173 - not supplied) will need to be fitted.
- C81, R111, R192 become not fitted (NF)
- C76, C78 should be 1nF
- R74 should be 0R
- L10 should be 0R
- C121, C122 should become not fitted (NF)

Typical values for CMX998 registers at 800MHz are (+32dBm PEP output):

- phase control = 67.5 degrees
- forward path attenuation = 0 dB
- feedback path attenuation = 14 dB
- Input (to TXI- & TXQ-) = 2V p-p

(Note: for 450MHz typical register values see section 3.2)

6.2.2 850MHz Operation using RF5110G

The RF5110G power amplifier on EV9980 is configured for 450MHz operation however the device is also capable of 800MHz - 900MHz operation. To use the RF5110G at 850MHz the changes in Table 5 must be implemented. A typical response of the power amplifier with these changes applied is shown in Figure 5 (measured using the PA connector, J24).

The 450MHz directional coupler is not appropriate for 850MHz operation and the low pass filter (C121 / C122 / L10) is not required. As a result further changes are required before the CMX998 can be used in closed-loop mode to linearise the RF5110G. These changes are detailed in Table 6.

Reference Designator	New Value (Old)
L25	1.6nH 0603 (0R)
C107	18pF (4.7pF)
C108	6.8pF (22pF)
C126	27pF (NF)
C134	39pF (NF)
L23	1.6nH (2.2nH)
L21	8.8nH (12.55nH)
R112	NF (180R)
R113	12nH 0603 (0R)
C98	27pF (330pF)

Table 5 – Component changes to EV9980 for 850MHz operation with RF5110G

Reference Designator	New Value (Old)
L4	0R (15nH)
C63 & C64	NF (6.8pF)
C77	NF (1pF)
R67	NF (51R)
L5	18R (15nH)
C8 & C9	270R (6.8pF)
L10	0R (18nH)
C121 & C122	NF (8.2pF)

Table 6 – Changes to EV9980 for 850MHz closed-loop operation

Typical values for CMX998 registers at 850MHz using the RF5110G, and modifications applied to EV9980 as detailed in Table 5 and Table 6, are (+32dBm PEP output):

- phase control = 202.5 degrees
- forward path attenuation = 0 dB
- feedback path attenuation = 24 dB
- Input (to TXI- & TXQ-) = 700mV p-p

(Note: for 450MHz typical register values see section 3.2 and for 800MHz with RF2173 PA see section 6.2.1)

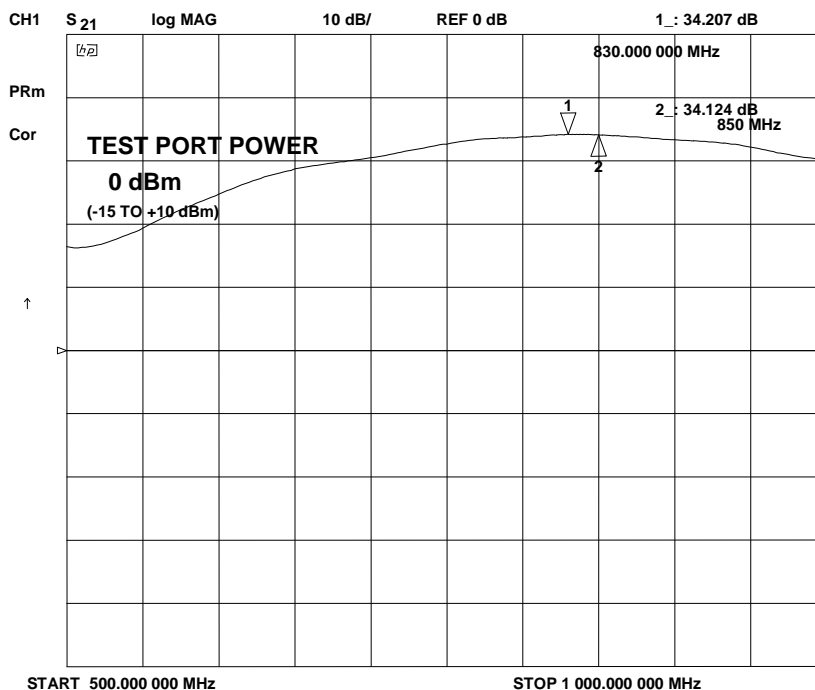

Figure 5 – RF5110G 850MHz, 0dBm Input Power

6.2.3 Improved Wideband Noise in 450MHz Operation

The EV9980 in default configuration is optimised for linearity. The RF5110G has circa 40dB of gain producing a high loop gain and excellent linearization. This is at the expense of wideband noise because the action of the loop causes the CMX998 up-converter output levels to back-off. The wideband noise can be improved by adding a 15dB attenuator before the RF5110G with the following changes:

- R113 becomes 150R (formerly 0R)
- R121 and R122 become 68R (formerly NF)

For further details see section 6.4.3.

6.2.4 Using an External Power Amplifier

The EV9980 can be used with an external power amplifier using connectors J7 and J4. The PA should be connected as shown in Figure 6 In addition the following changes should be made:

- Move C55 (1nF) to C54
- Move C27 (1nF) to C30
- Fit C35 as a 0R (0603 resistor)

The external power amplifier should require a drive level of approximately 0dBm. The feedback signal to J4 should meet the requirements of the CMX998 down-converter input. The output power of the PA can be any value as long as the feedback level to J4 is within the operating range of the IC; the optional attenuator is shown where this levels can be adjusted.

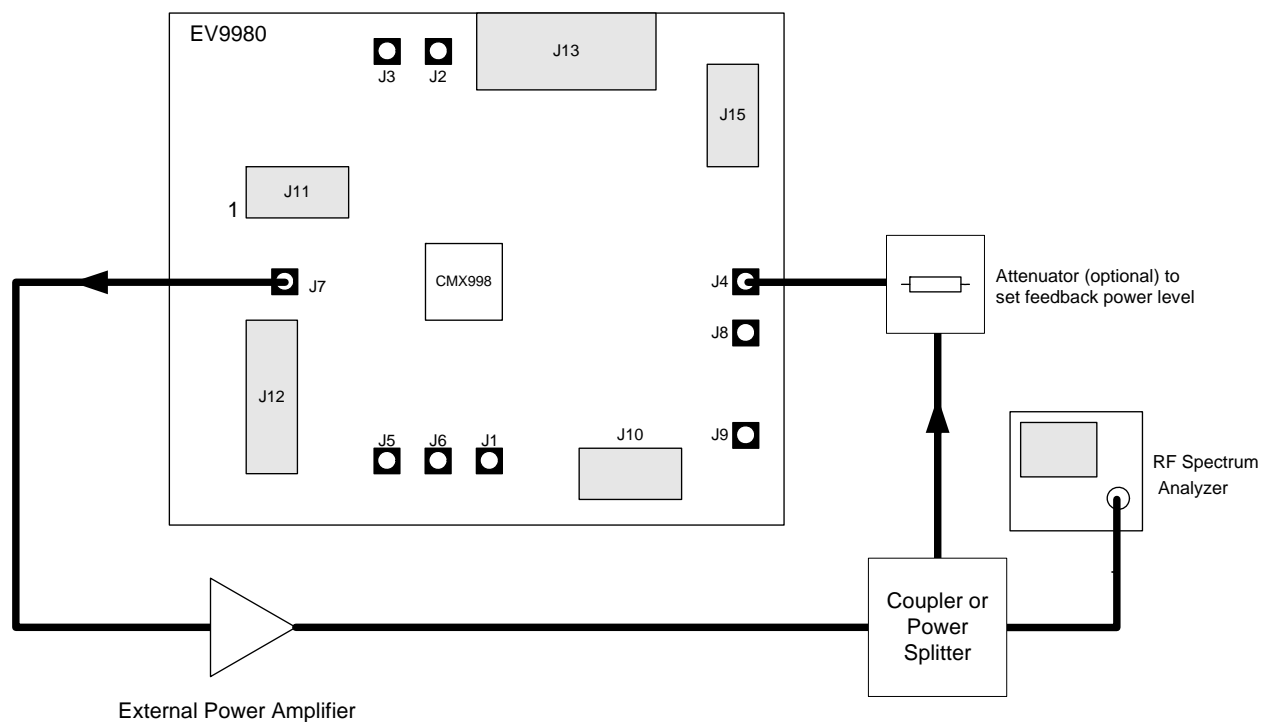

Figure 6 – EV9980 Configuration with an external power amplifier

6.3 Software Description

The EV9980 does not require any embedded firmware. The CML product PE0002, available separately, can be used with the EV9980 and the related PC software (ES9980xx.exe). The ES9980 application allows the user to interact with the EV9980 via an easy to use graphical interface. It consists of three tabs: each one representing a particular set of registers or a particular function of the CMX998.

To select a tab simply click on the corresponding name in the row at the top of the program window. Setting or clearing the check box associated with a bit of a register will cause that bit to be set or cleared when the register is next written to. If the 'Auto Write' check box is set a register will be written whenever a check box or list box associated with it is modified. This removes the need to click the 'Write' button associated with that register. The program can be closed at any time by clicking the 'Close' button or by pressing 'Alt' and 'F4' keys simultaneously.

6.3.1 The CMX998 Regs (\$01-\$06) Tab

The CMX998 Regs (\$01-\$06) Tab gives access to the General Control register, Gain Control register, Phase Control register and General Reset command, see Figure 7. Also on this tab, the C-BUS header to be used can be selected.

In the case of the gain and phase control registers, slide bars have been used to allow easy control during operation.

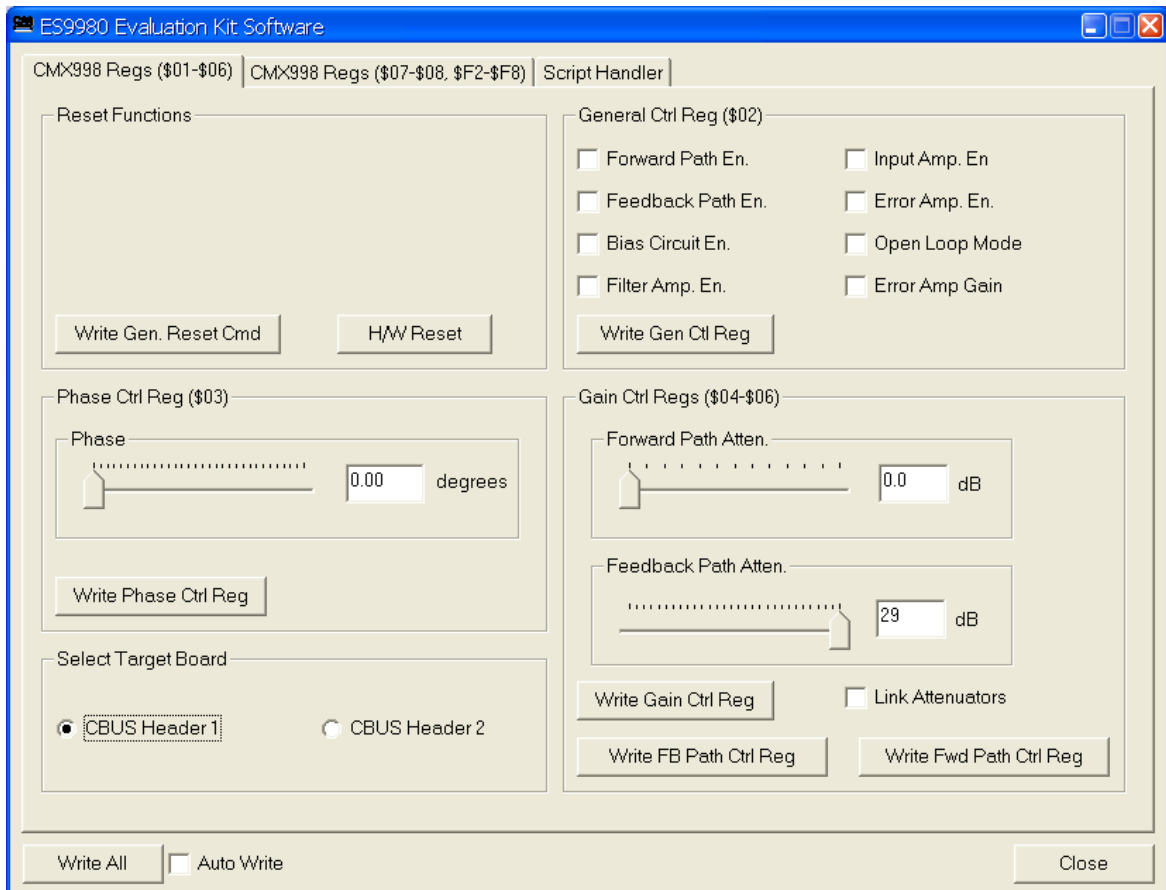

Figure 7 – The CMX998 (\$01-\$06) Tab

6.3.2 The CMX998 Regs (\$07-\$08, \$F2-\$F8) Tab

The CMX998 Regs (\$07-\$08, \$F2-\$F8) Tab gives access to the Aux Control and Frequency Control registers, see Figure 8. This tab also allows the registers \$F2 to \$F8 to be read individually.

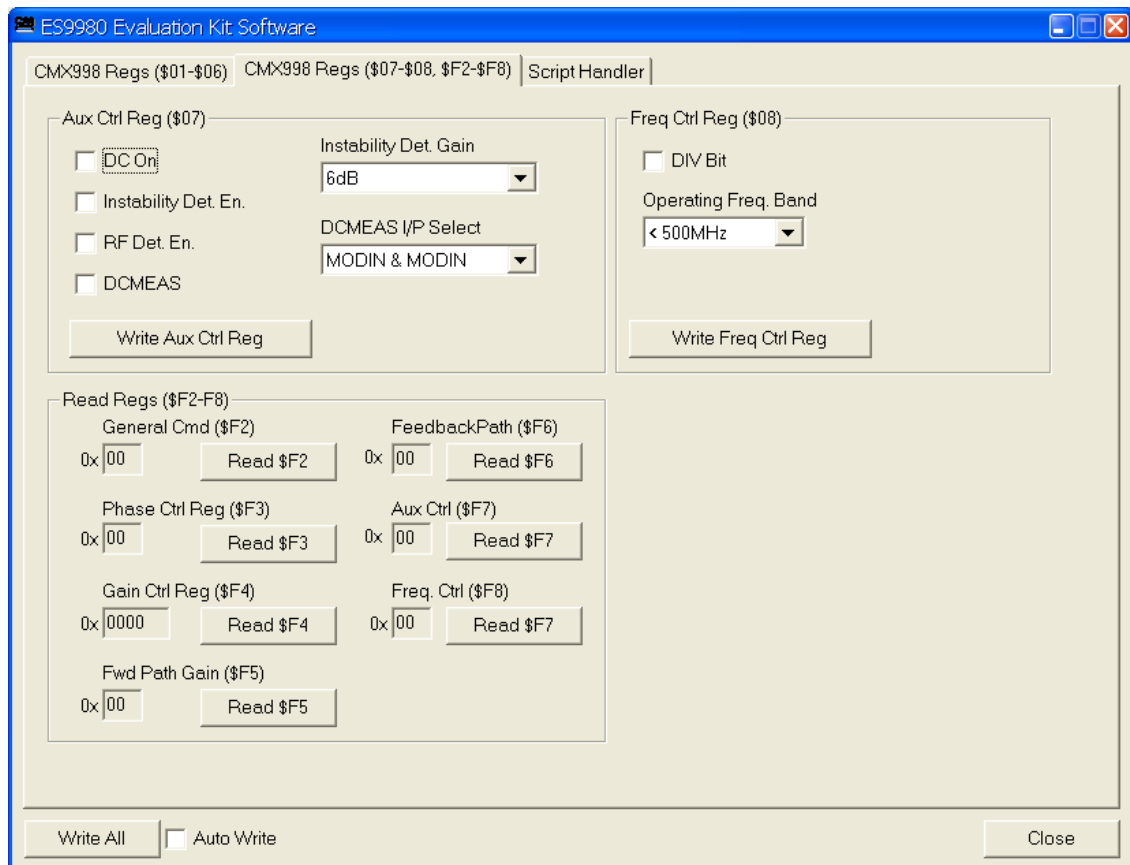

Figure 8 – The CMX998 (\$07-\$08, \$F2-\$F8) Tab

6.3.3 The Script Handler Tab

The Script Handler Tab (shown in Figure 9) allows the execution of script files consisting of register write, read, and delay commands. These are plain text files on the PC, which are compiled via the GUI but executed by the E2 Microprocessor on the PE0002 board. The script language is documented separately in the “Script Language Reference” document, which can be downloaded with the PE0002 support package from the CML website. Control of the EV9980 does not require the use of script files.

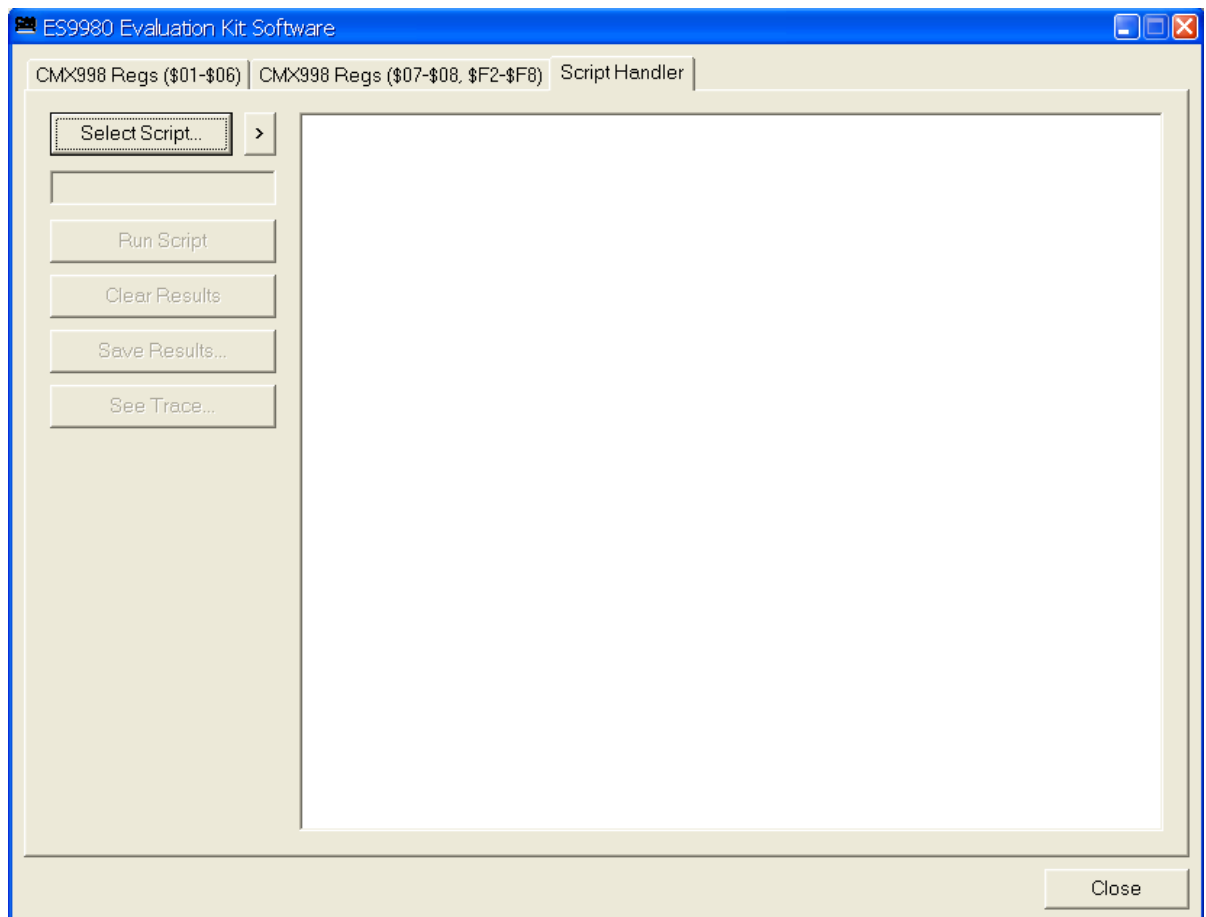

Figure 9 – The Script Handler Tab

To select a script file, click on the ‘Select Script’ button. The Open File Dialog is displayed. Browse and select the script file. The folder that contains the script file will be the working folder of the script (i.e. all the files referenced in the script will be searched in this folder). Alternatively, select a script file from the recent files list. Click on the ‘>’ button to display the list.

The results window displays the values returned by the script. These results can be saved to a text file or discarded by clicking on the ‘Save Results’ or ‘Clear Results’ buttons, respectively. When a script file is being executed the ‘Run Script’ button will change to be the ‘Abort’ button, the rest of the tab will be disabled and the other tabs cannot be selected.

After a script has finished running and when trace data is available, the ‘See Trace...’ button will be enabled. Up to 131072 C-BUS transactions can be logged in the PE0002 board. Click in the ‘See Trace...’ button to display the Trace dialog box. Note that the C-BUS transactions are only logged if the feature has been enabled in the script. See the “Script Language Reference” document for details.

6.4 Application Information

6.4.1 Error Configuration

The error amplifier configuration used on the EV9980 is shown in Figure 10. The following conditions apply to the values fitted on the EV9980, the 1st Pole is at ~16kHz, the 2nd Pole is at ~32kHz and the Zero is at ~320kHz. These can be changed for any user requirement.

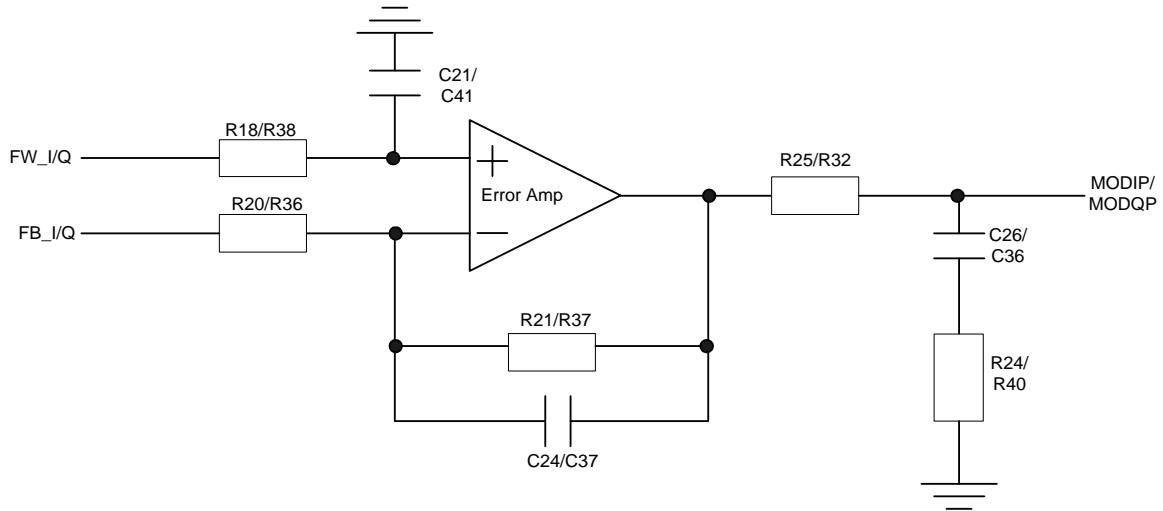

Figure 10 – Error Amplifier Configuration

6.4.2 Typical Performance of Closed Loop Configuration

Typical performance of the EV9980 with two-tone and 18ksymbols/s $\pi/4$ DQPSK modulation is given in the following sections.

6.4.2.1 RF5110G Operation at 450MHz

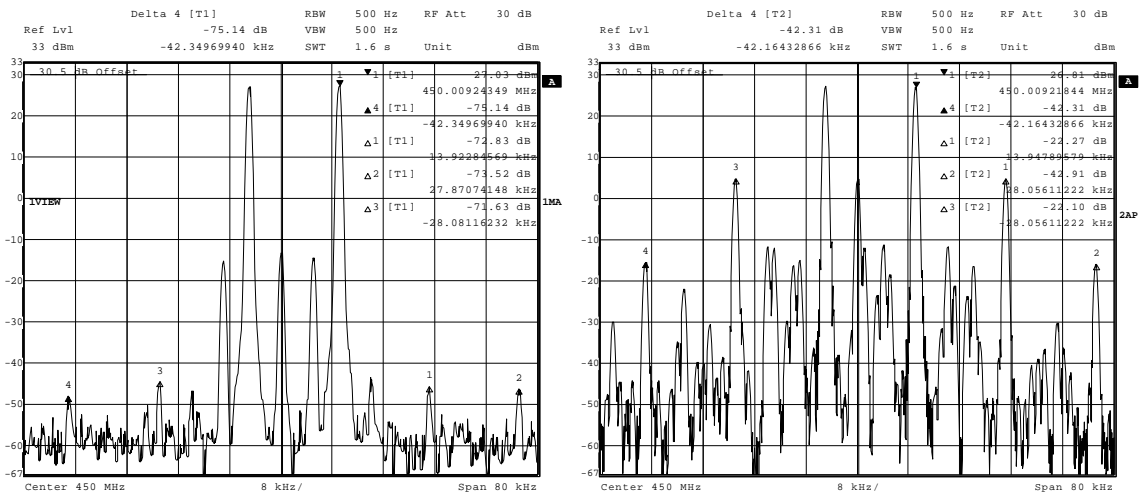

Figure 11 – CMX998 and RF2175 performance at 450MHz (closed loop (left) and open loop (right) at approximately the same PEP output level)

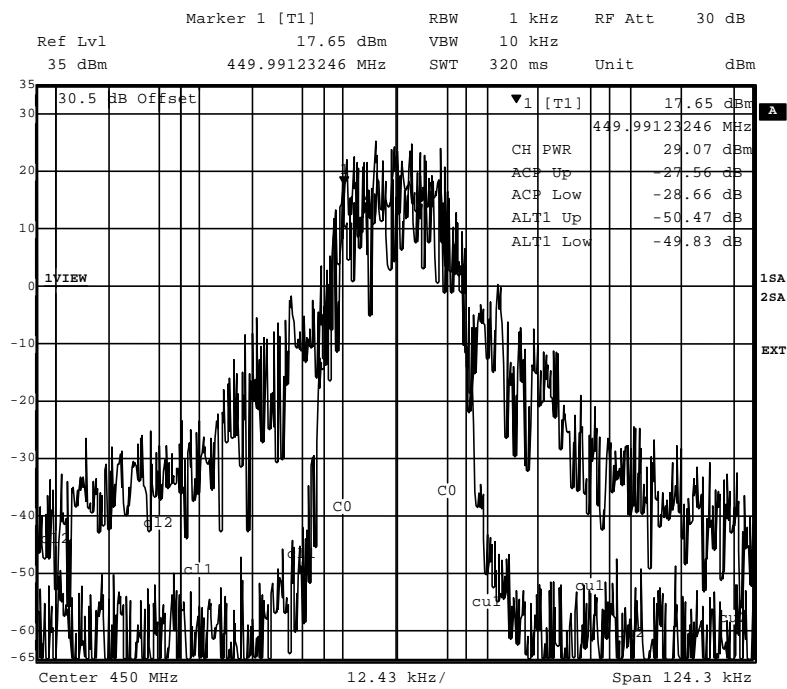
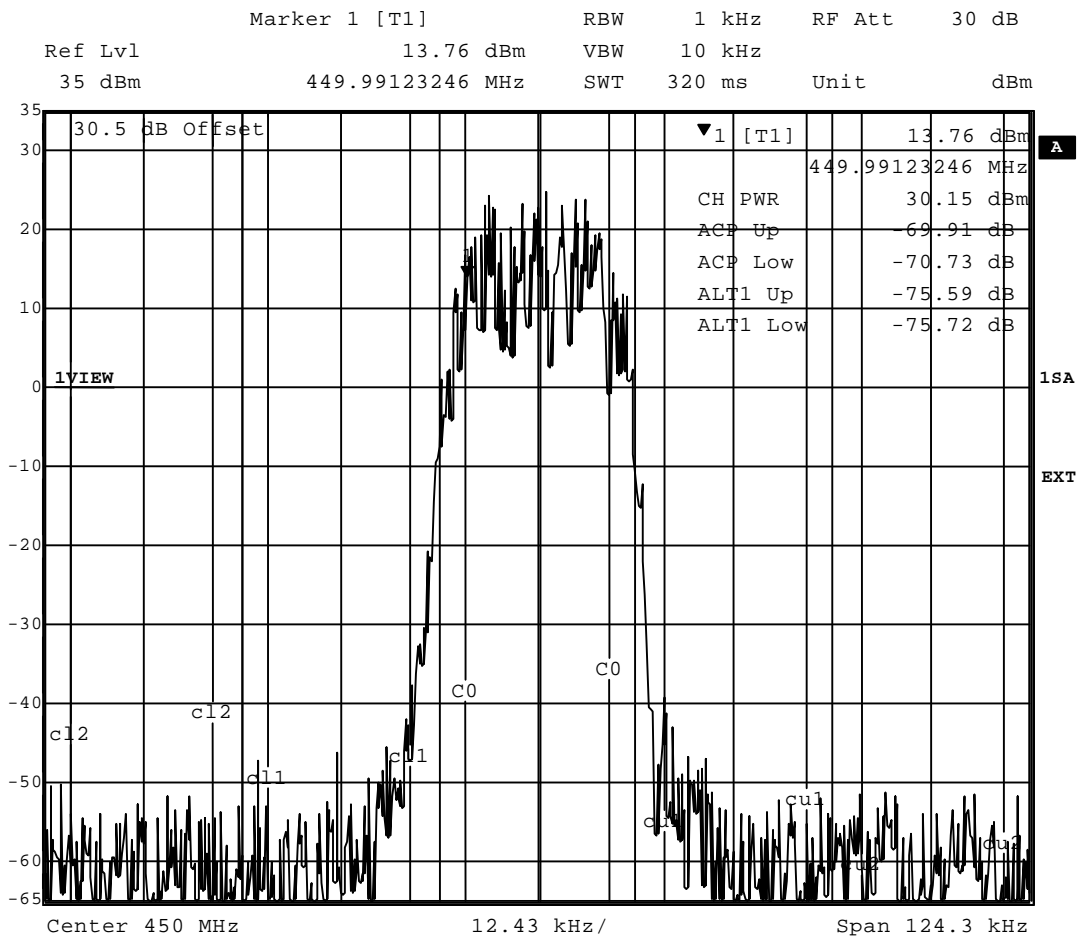

Figure 12 – CMX998 and RF5110G performance at 450MHz
(closed loop (lower) and open loop (upper) same PEP output level with 18ksymbols/s $\pi/4$ DQPSK modulation)



**Figure 13 – CMX998 and RF5110G performance at 450MHz
(closed loop with 18ksymbols/s $\pi/4$ DQPSK modulation)**

6.4.2.2 RF2173 at 800MHz

The EV9980 may be configured for 800MHz operation using the RF2173 power amplifier, see section 6.2.1 for details.

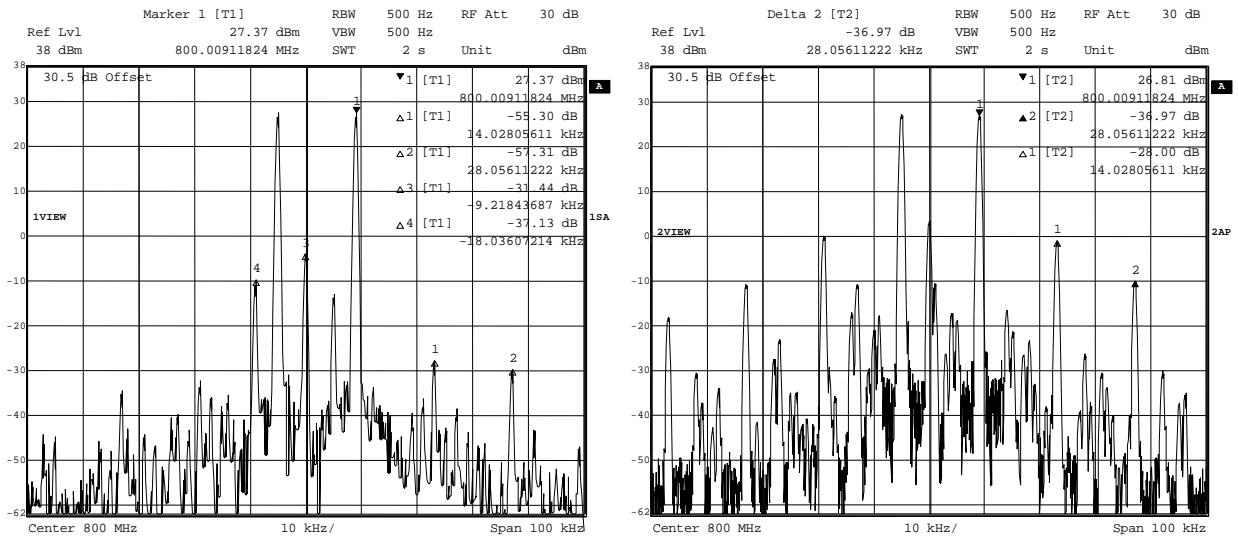

Figure 14 – CMX998 and RF2173 performance at 800MHz (closed loop (left) and open loop (right) at approximately the same PEP output level)

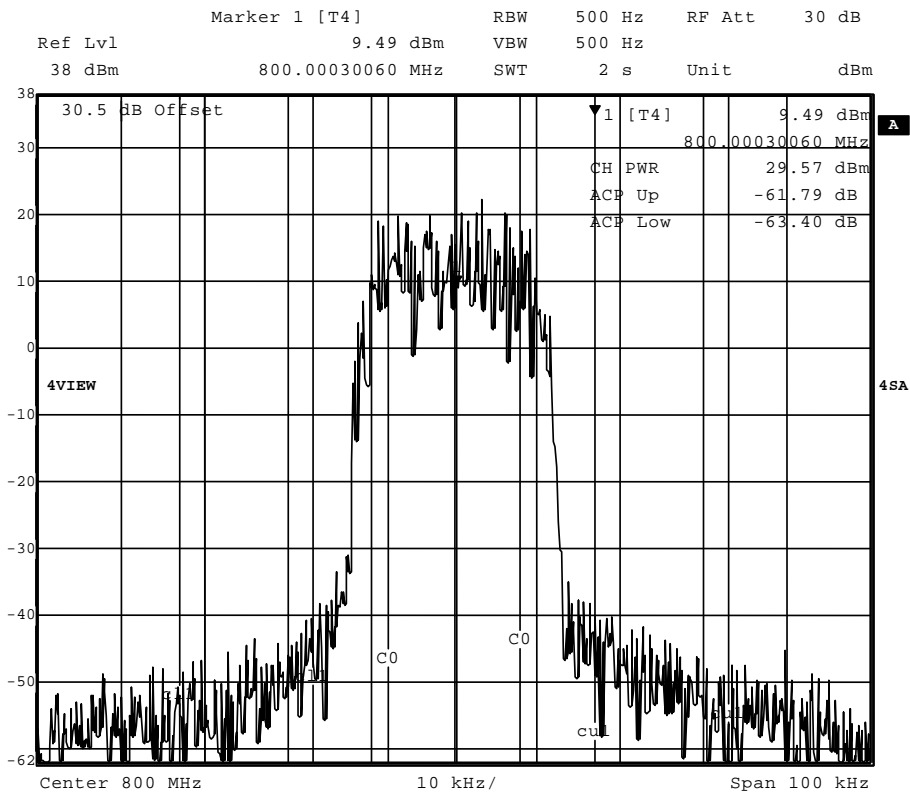

Figure 15 – CMX998 and RF2173 performance at 800MHz (closed loop 14dB feedback path attenuation, 18ksymbols/s $\pi/4$ DQPSK modulation)

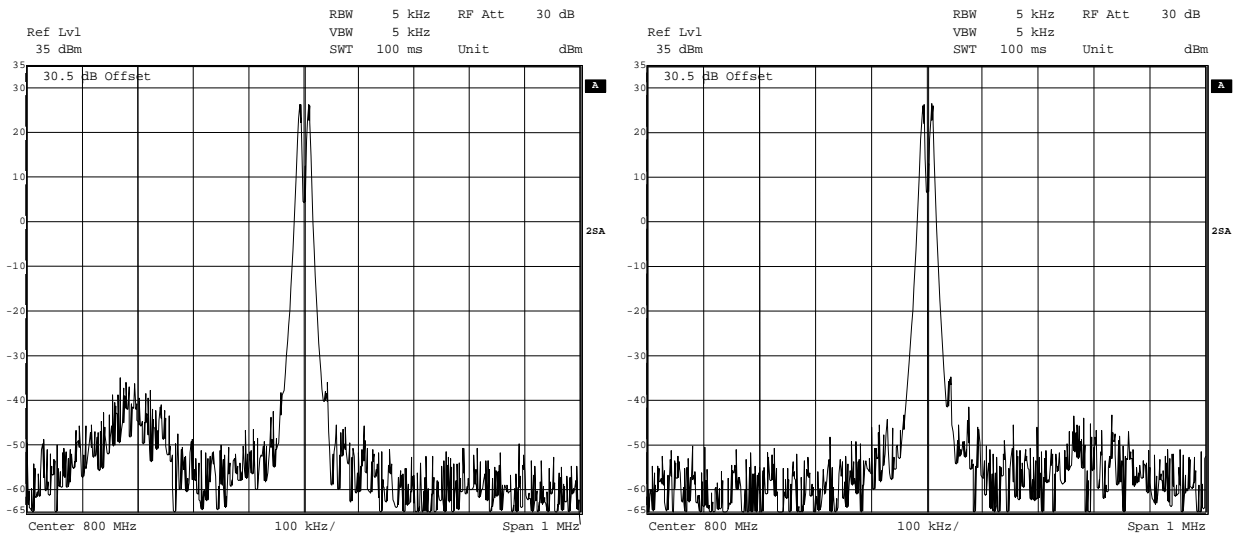

Figure 16 – CMX998 and RF2173 performance at 800MHz

(closed loop with phase control at extremes of stability = 123.75 deg. (left) and 11.25 deg. (right), showing classic peaking of noise when feedback phase is incorrect)

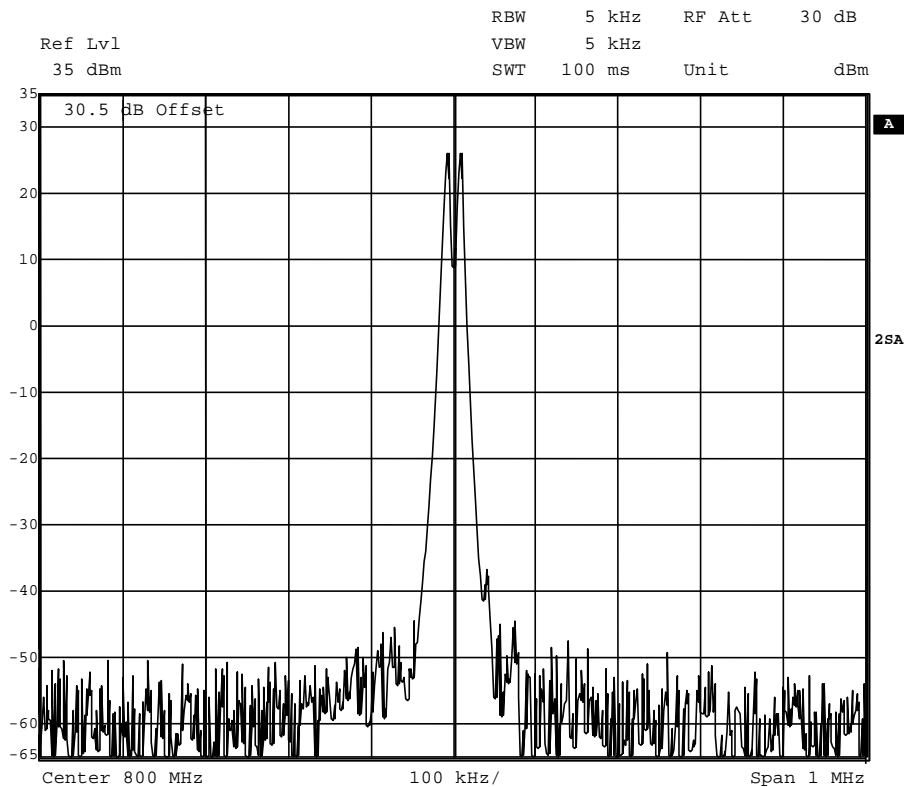
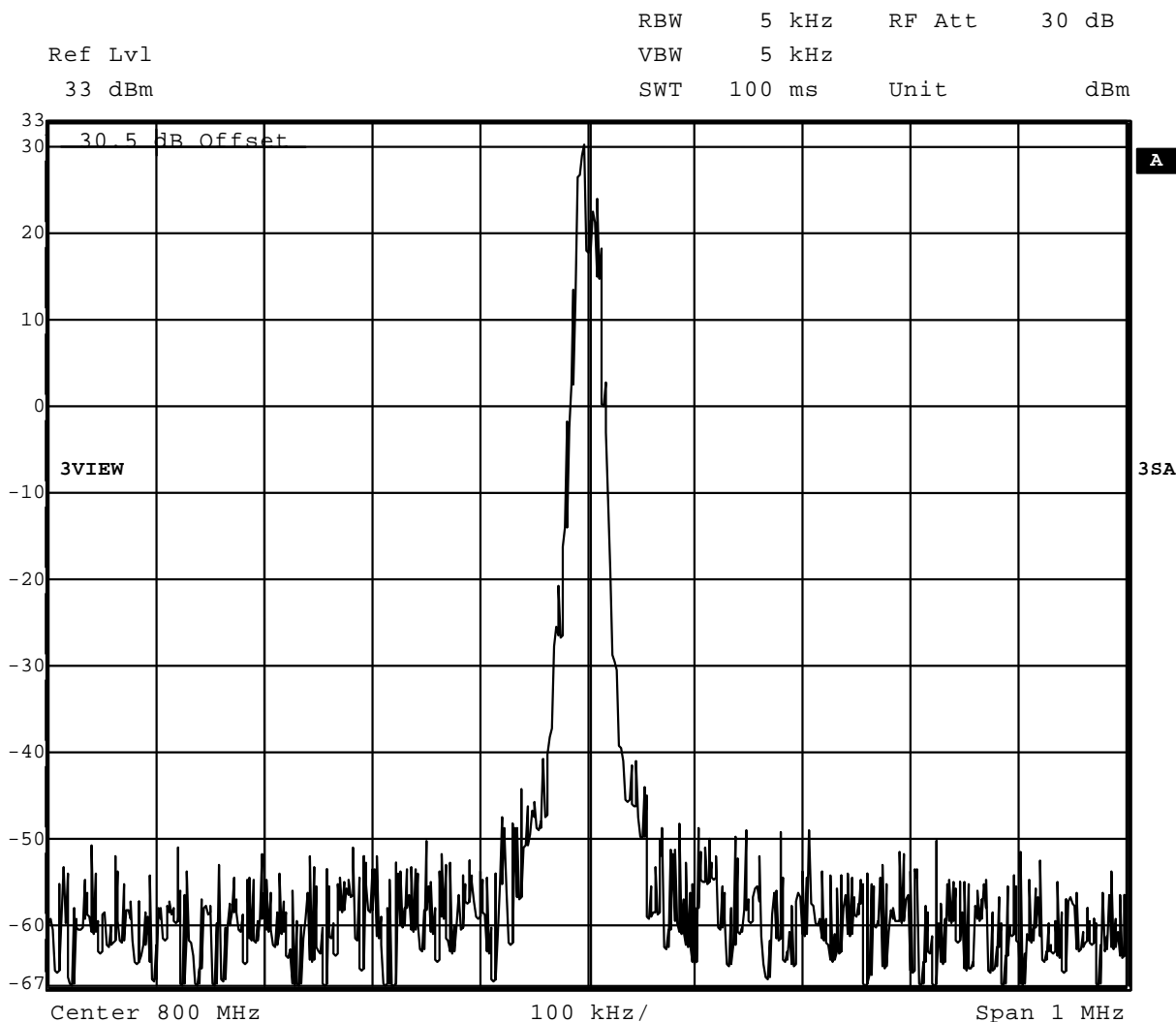

Figure 17 – CMX998 and RF2173 performance at 800MHz

(correctly adjusted closed loop with phase control of 67.5 deg. resulting in a clean spectrum)

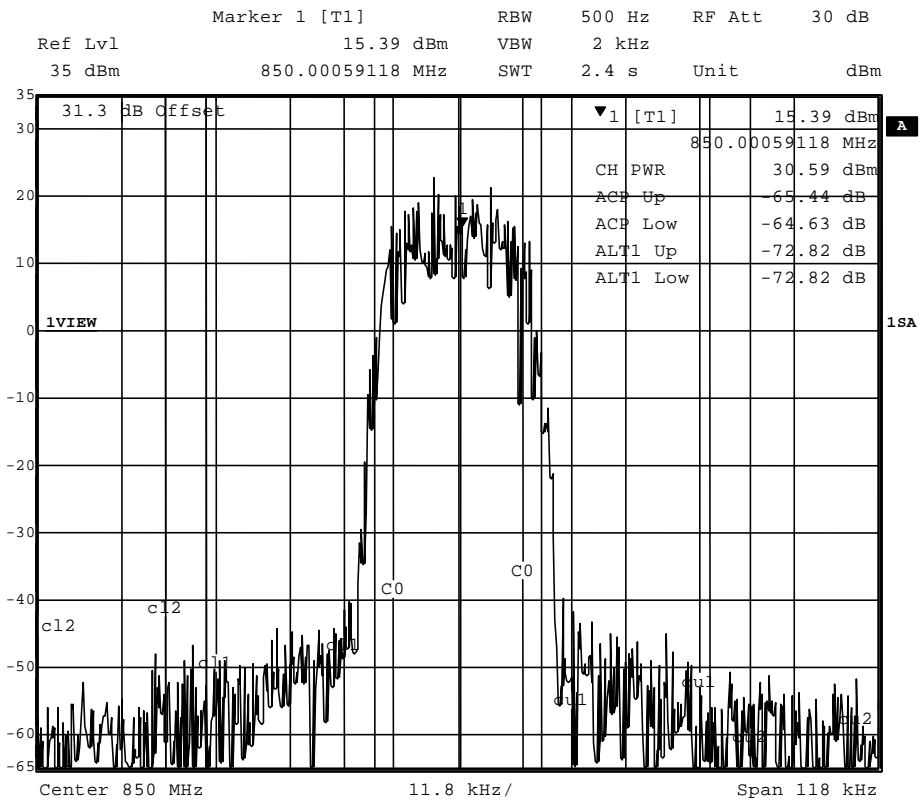

**Figure 18 – Broadband (1MHz) plot of CMX998 and RF2173 performance at 800MHz
(closed loop with 18ksymbols/s $\pi/4$ DQPSK modulation)**

6.4.2.3 RF5110G at 850MHz

The EV9980 may be configured for 800MHz operation using the RF5110G power amplifier, see section 6.2.2 for details.

Measured with TETRA $\pi/4$ -DQPSK modulation adjacent channel power is circa 64dB and alternate channels 73dB. The two-tone linearization is circa 30dB, as shown in Figure 20 (Phase shifter = 202.5 degrees, Forward path = 0 dB, Feedback path = -24 dB). The clean linearised spectrum is shown in Figure 21 and the edges of stability are shown by the characteristic noise 'humps' in Figure 22.



**Figure 19 – RF5110G Closed Loop Operation at 850MHz
(closed loop with 18ksymbols/s $\pi/4$ DQPSK modulation)**

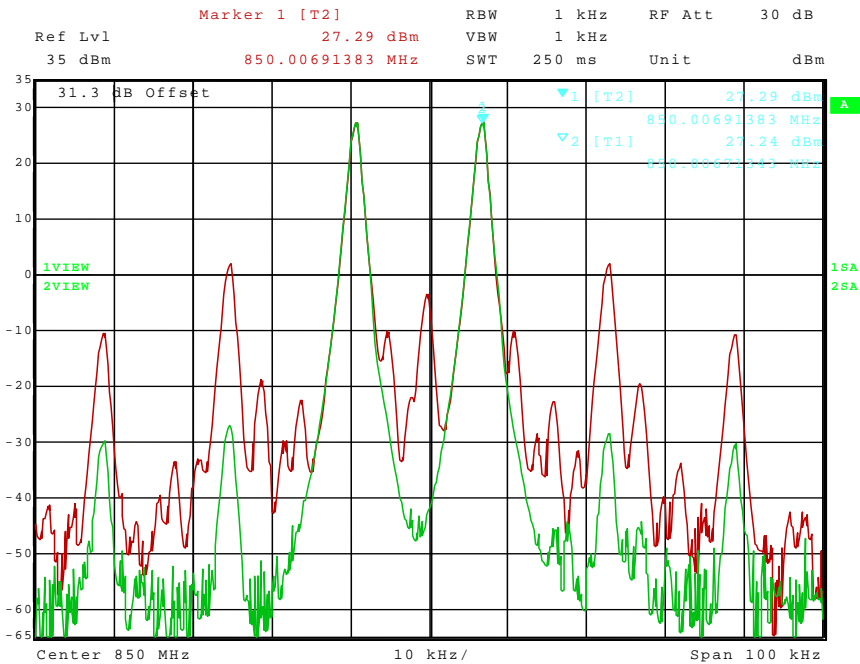

Figure 20 - Two-tone linearization improvement

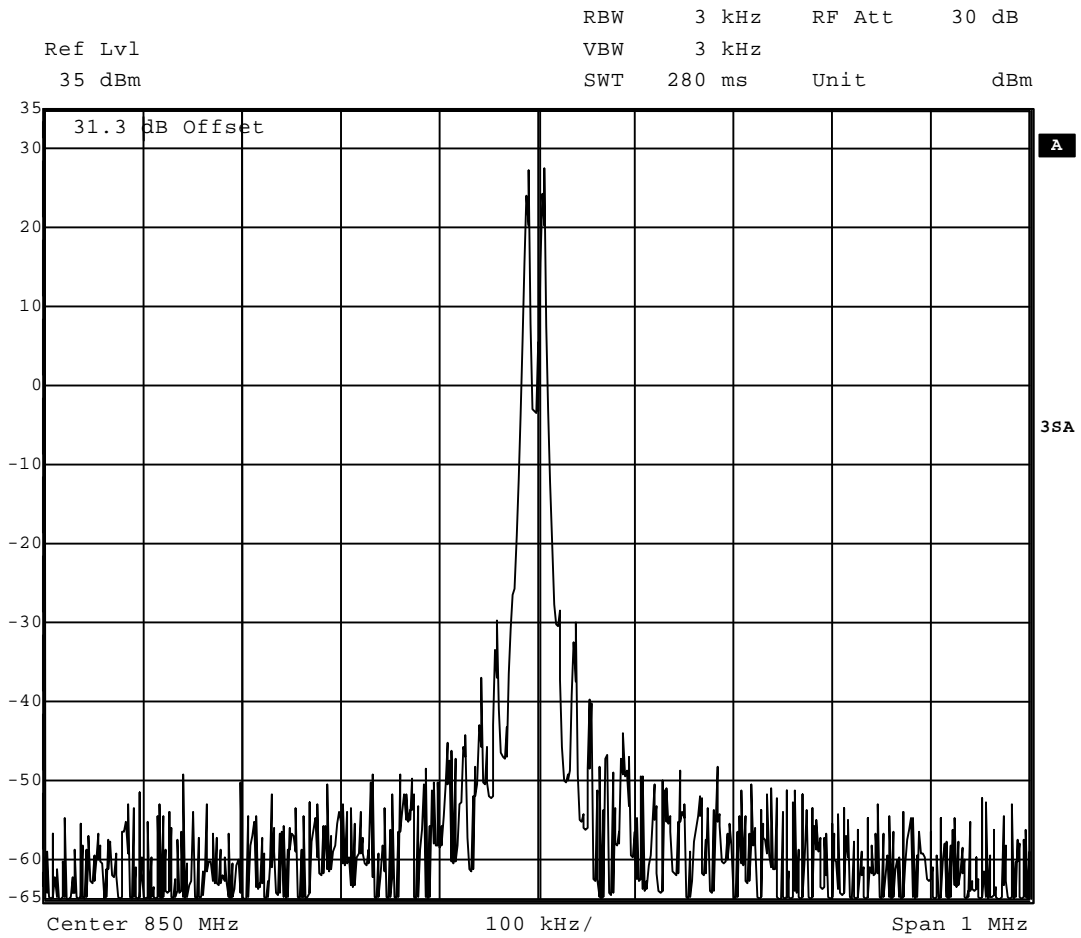
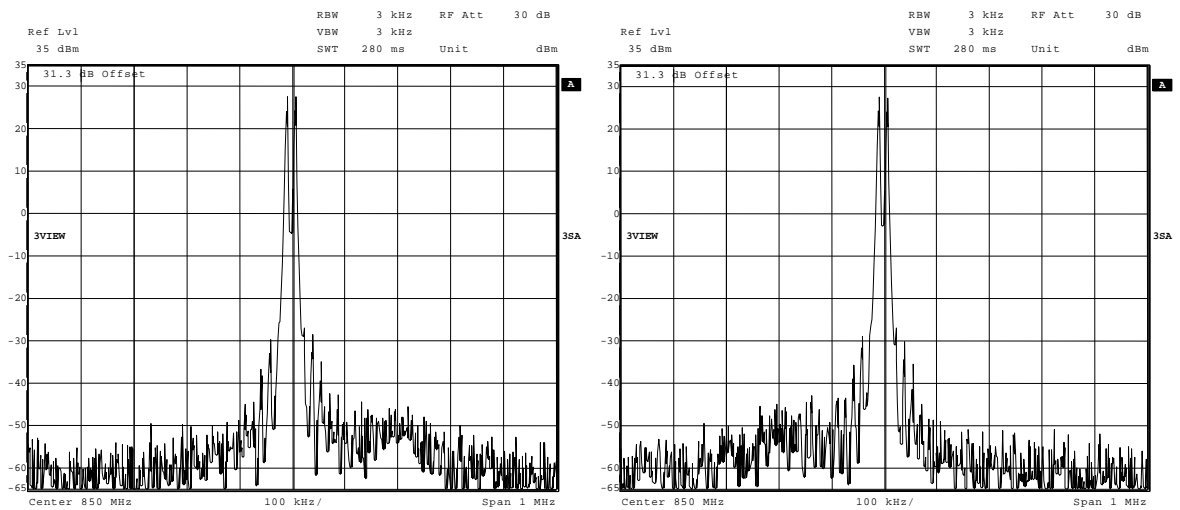

Figure 21 – Wideband (1MHz) plot of linearised two-tone signal



**Figure 22 - Wideband response at extreme loop phase settings
(168.75 degrees - left and 247.5 degrees - right)**

6.4.3 450MHz TETRA Operation and Wideband Noise

The EV9980 is initially configured for optimum linearization, as demonstrated by the plots in section 6.4.2. For compliance with the TETRA standard it is necessary to trade-off some of the linearity for better wideband noise. In the default configuration, noise measured at 5MHz offset is typically -137dBc/Hz . This is due the high gain (circa 40dB) of the RF5110G. The action of the Cartesian loop causes the output of the CMX998 to reduce to achieve the appropriate PA output (as controlled by the feedback path levels), the result being that the output signal of the CMX998 up-converter is reduced to circa -15dBm . Introducing an attenuator before the PA corrects for the PA gain raising the output level of circa 0dBm. This results in an improvement in measured wideband noise to circa -147dBc/Hz or better. The attenuator used in the following measurements has a nominal loss of 15dB and details are given in section 6.2.3.

Frequency Offset	Measurement	TETRA Limit (1W, 450MHz)	TETRA Limit (3W, 450MHz)
100 kHz	-79.5 dBc	75 dBc	78 dBc
250 kHz	-86 dBc	80 dBc	83 dBc
500 kHz	-90 dBc	80 dBc	85 dBc
5 MHz	-104 dBc	100 dBc	100 dBc

Table 7 – EV9980 Typical wideband noise performance

(measured at 467.5MHz, noise measured in TETRA filter bandwidth (18kHz) relative to the transmitter mean power)

With the improved wideband noise linearity is slightly degraded, however it is still satisfactory with adjacent channel power of 63dB and alternate channel power of 72dB.

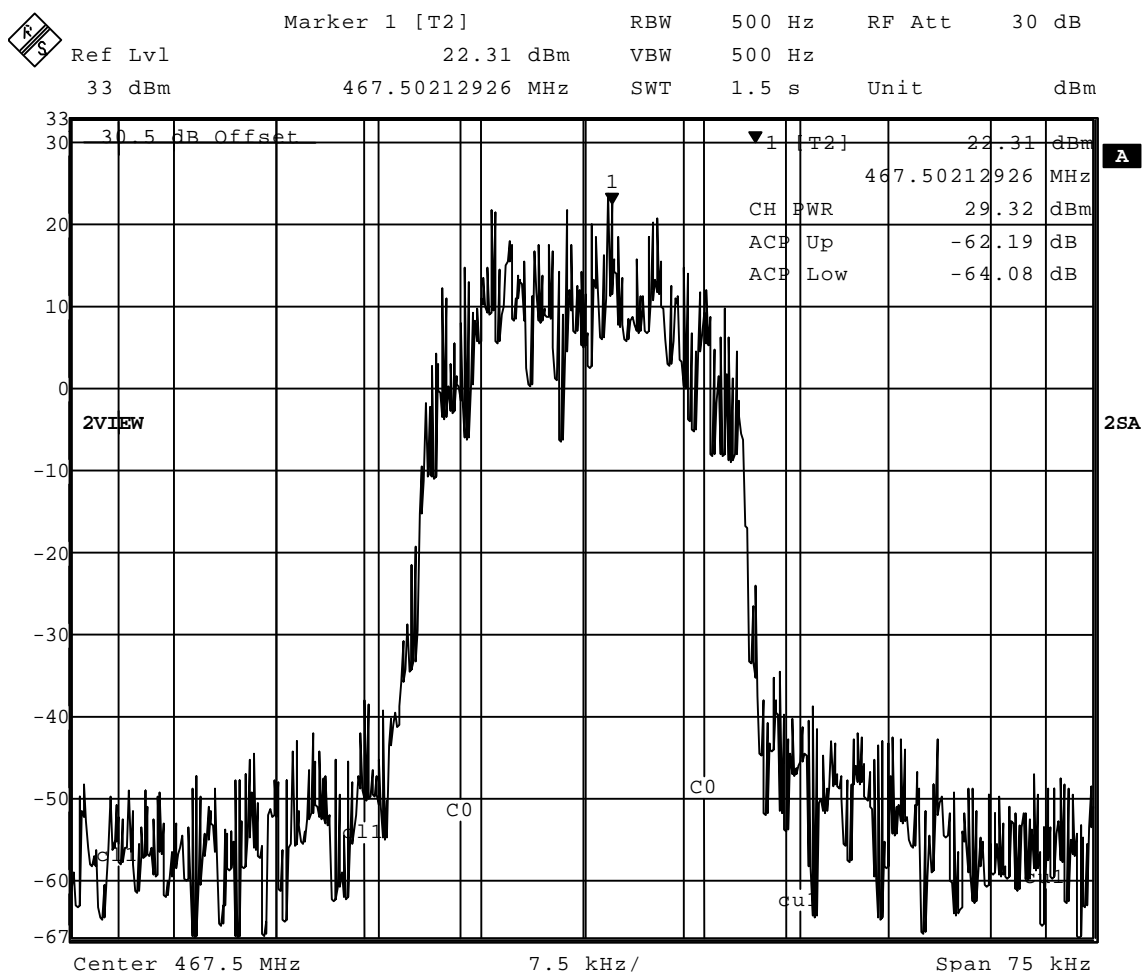

Figure 23 – TETRA adjacent channel power measurement (with reduced loop gain and optimised wideband noise)

6.4.4 Testing the CMX998 with the CMX981

The EV9980 has an I/Q interface to the EV9810 through the use of a 10-way header. The connections should be made, as follows:

EV9980 (J11)		EV9810 (J9)	
Label	Pin No	Label	Pin No
981_Q+	1	QTXP	10
981_Q-	3	QTXN	8
GND A	5	GNDANALOG	6
981_I-	7	ITXN	4
981_I+	9	ITXP	2

Table 8 – EV9980 and EV9810 interconnection details

(Note: See also Figure 25).

The Tx output of the CMX981 is differential I/Q, with a single ended signal level of 1V p-p @1.28V dc. The CMX998 input amplifiers need to convert this differential signal into a single ended 1V p-p @1.6V dc signal. A typical configuration for the input amplifiers on the CMX998 is shown in Figure 24.

NOTE: The default component values fitted to the EV9980 are not those shown in Figure 24. The user must modify the CMX998 Input Amplifier configuration on the EV9980 in order to operate with an EV9810 kit.

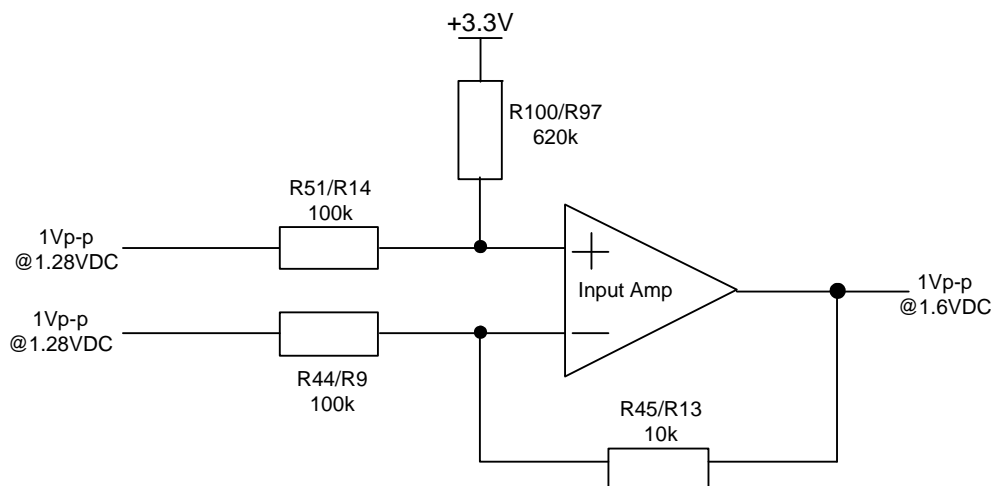

Figure 24 – CMX998 Input Amplifier Configuration

The results shown in this section were taken with the CMX998 configured as Figure 25. The component changes to the EV9980 to allow this configuration to work are:

- Move C55 to C54
- Move C27 to C30
- Make C35 a 0R (0603 resistor)
- Open circuit the PA input
- Do not connect V_{PA}

To get ~ 0 dBm after the splitter (splitter loss assumed to be ~ 3 dB) the attenuator in the forward path = 0dB, the attenuator in the feedback path ~ 23 -24dB. The optimal phase setting will vary between setups as it is determined by the length of leads used to complete the RF loop. On a 1MHz span on the spectrum analyser, check for noise humping to ensure correct phase has been set.

The plots in Figure 26, Figure 27, Figure 28, Figure 29 and Figure 30 show the ACP performance, an open and closed loop comparison, trellis diagram, constellation diagram and symbol/error table respectively.

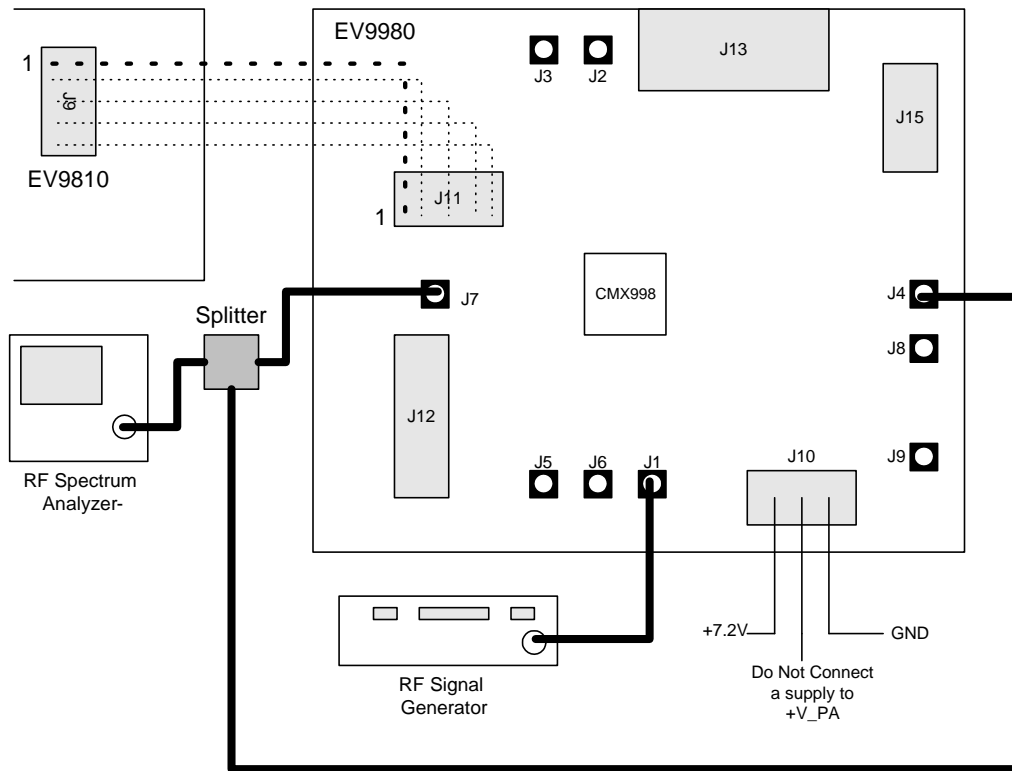

Figure 25 – CMX998 Configuration for testing with CMX981

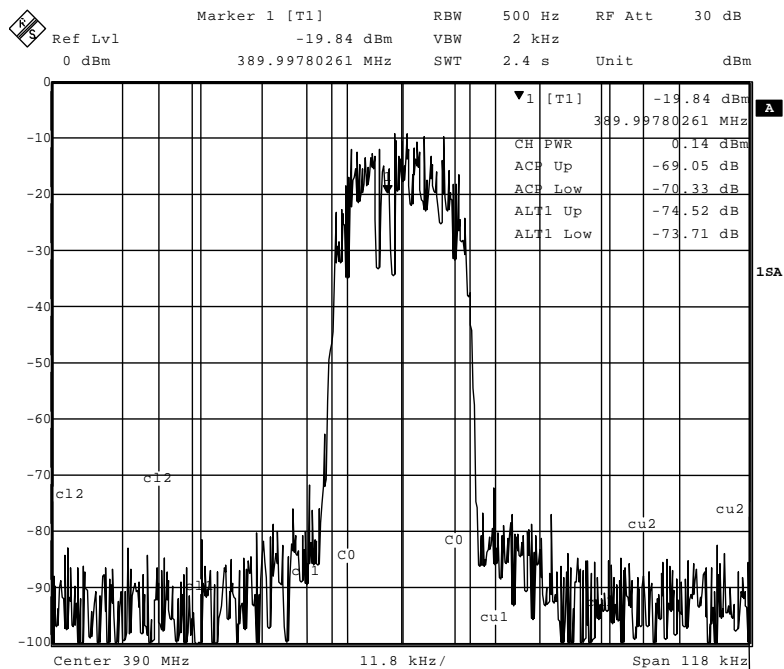

Figure 26 – 1st and 2nd ACP Performance

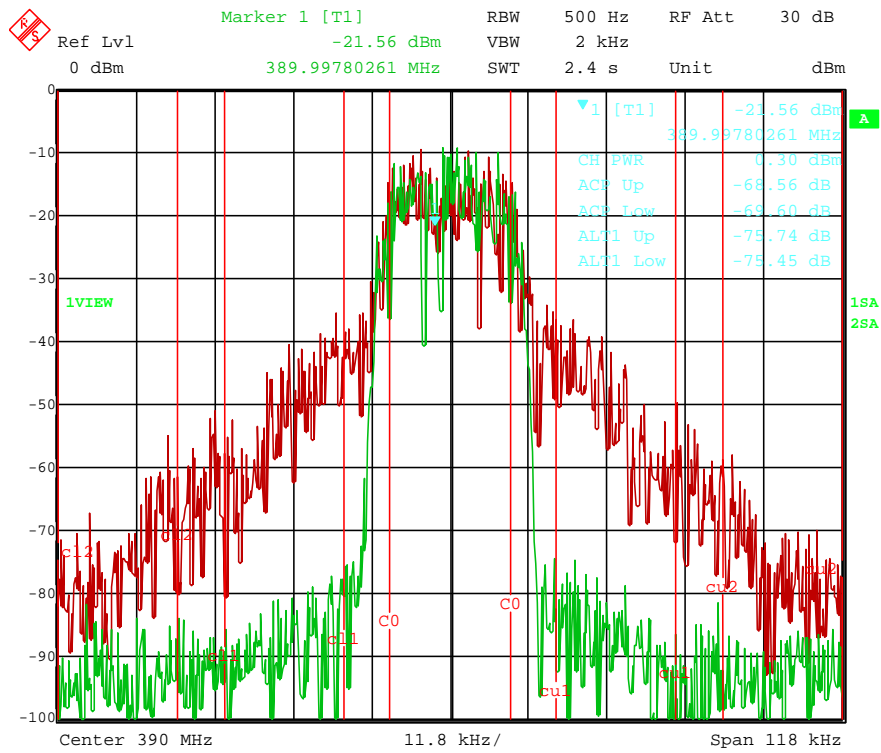

Figure 27 – Open and closed loop performance comparison

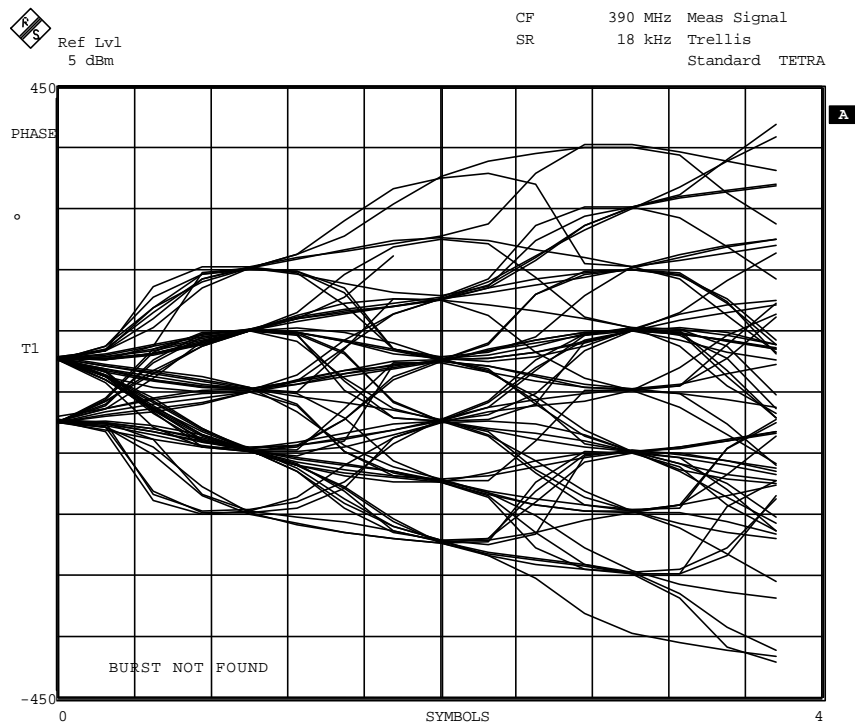

Figure 28 – Trellis Diagram

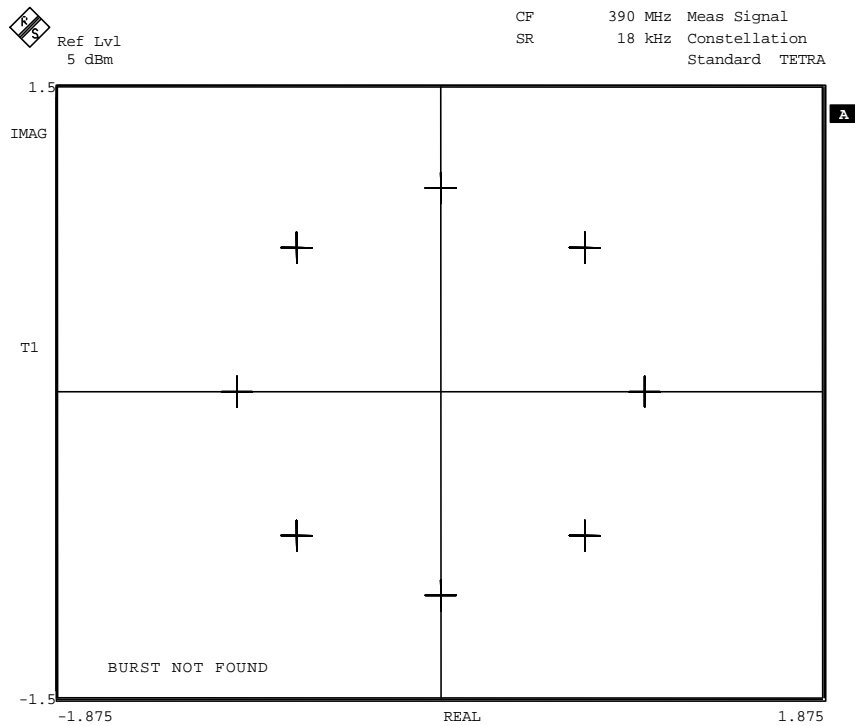

Figure 29 – Constellation Diagram

Ref Lvl 5 dBm

CF 390 MHz
SR 18 kHz Symbol/Errors Standard TETRA

Symbol Table					
0	1111001	10010011	00000100	01110100	10111011
40	01110010	10010101	01011011	11010111	01011010
80	00111001	10000111	10111110	01000110	01110100
120	11010011	10110010	00000111	11110110	11000110
160	11100110	11101000	10111110	10101110	01001011
200	00100010	11001111	11110111	01100101	11101011
240	11110010	00000100	01100000	11010111	01010011
280	10001111	10010011	10011011	00101001	10101001
320	11100110	00000000	10000001	01011111	00110110
360	11010010	01011100	11011010	01110001	00000111
400	00101100	01111101	01111000	01111010	00001111
440	11100011	11011111	11011001	00111101	10101101
480	00000111	1000			

Error Summary		BURST NOT FOUND	
Error Vector Mag	3.62 % rms	6.81 %	Pk at sym 8
Magnitude Error	2.64 % rms	-6.02 %	Pk at sym 6
Phase Error	1.42 deg rms	2.97 deg	Pk at sym 205
Freq Error	-3.50 Hz	-3.50 Hz	Pk
Amplitude Droop	0.79 dB/sym	Rho Factor	0.9977
IQ Offset	3.48 %	IQ Imbalance	0.54 %

Figure 30 – Symbol/Error Table

6.5 Troubleshooting

The CMX998/EV9980 is a complex RF system. If incorrectly programmed or modified, results will be at variance from datasheet performance. Please study the IC datasheet, this manual and the associated schematics and layout drawings carefully when troubleshooting.

This section provides some suggestions to help users resolve application issues they might encounter.

6.5.1 Closed Loop Operation

Error Observed	Possible Cause	Remedy
Instability, poor adjacent channel performance	Loop Phase is incorrect	Try adjusting the Phase Control register while analysing the RF output to see if spectrum improves
PA supply draws more 1.5A	Loop Phase incorrect	See above remedy above
No RF Output	PA control volts are low, relevant circuitry not enabled or I/Q signals not applied	Check control volts at TL20 (or TL12 for RF2173) to see if voltage is close to +2.8V dc, try re-enabling circuitry in CMX998 or measure I/Q signal at TL1
No linearization of PA appears to be happening	Loop switch in wrong position, forward/reverse attenuator incorrectly set	Check state of loop switch, and adjust attenuator to see if spectrum improves
No linearization of PA appears to be happening	Error amp gain reduction mode has been selected	
Discrete spurious present on transmission at 18kHz offset from carrier causing degrading adjacent channel power when using EV9810 to generate modulation	Insufficient isolation between EV9980 and EV9810 power supplies	Ensure sufficient de-coupling between power supplies or use separate bench power supplies for EV9810 and EV9980
RF output from 450MHz PA is low (e.g. +27dBm mean)	Voltage drop in wires to PA results in a low supply voltage	Measure the PA supply voltage at the PA pin. Increase supply voltage so that at least 3.6V is seen at the pin. NB: Do not exceed manufactures absolute maximum value when the PA is not transmitting

Table 9 – Closed Loop possible errors

6.5.2 Open Loop Operation

Error Observed	Possible Cause	Remedy
No RF Output	Relevant circuitry not enable, or I/Q signals not applied	Try re-enabling circuitry in CMX998 or measure I/Q signal at TL1

Table 10 – Open Loop possible errors

7 Performance Specification

7.1 Electrical Performance

7.1.1 Absolute Maximum Ratings

Exceeding these maximum ratings can result in damage to the Evaluation Kit.

	Min.	Max.	Units
Supply Voltage ($V_{IN} - V_{SS}$)	0	8.0	V
Supply Voltage ($V_{PA} - V_{SS}$)	0	6.0	V
Current into or out of V_{IN} , V_{PA} and V_{SS} pins	0	+2.0	A
Current into or out of any other connector pin	-20	+20	mA

7.1.2 Operating Limits

Correct operation of the Evaluation Kit outside these limits is not implied.

	Notes	Min.	Max.	Units
Supply Voltage ($V_{IN} - V_{SS}$)		5.25	8.0	V
Supply Voltage ($V_{PA} - V_{SS}$)	1	3.0	4.8	V

Notes:

1. PA supply voltage should be measured at the Power Amplifier (U2 or U10) power supply pin.

7.1.3 Operating Characteristics

For the following conditions unless otherwise specified:

$$V_{IN} - V_{SS} = 7.2V, V_{PA} - V_{SS} = 3.7V, T_{amb} = +25^{\circ}C.$$

	Notes	Min.	Typ.	Max.	Units
DC Parameters (Excluding PA Supply)					
I _{DD} (CMX998 powersaved)	2	–	3	–	mA
I _{DD} (All CMX998 Circuitry Enabled)	2	–	140	–	mA
AC Parameters					
Up-Converter Output					
Output power		–	0	–	dBm
Attenuator Range		0	–	30	dB
Attenuator Step Size		–	2.5	–	dB
Down-Converter Input					
Input impedance		–	50	–	Ω
Input Level		-22	–	+7	dBm
Attenuator Range		0	–	29	dB
Attenuator Step Size		–	1.0	–	dB
I/Q Input Signal					
Amplitude		–	1.6	2.0	Vp-p
DC Level		–	0	–	V dc
LO Input					
Input impedance		–	50	–	Ω
Frequency range		200	–	2000	MHz
Input Level		-15	-10	–	dBm
450MHz PA Output					
Input impedance		–	50	–	Ω
Frequency range		450	460	470	MHz
Output Level (PEP)	3	–	+33	–	dBm
Adjacent Channel Power	4	-65	-69	–	dBc
Alternate Channel Power	4	-70	-75	–	dBc
800MHz PA Output (when PA is fitted)					
Input impedance		–	50	–	Ω
Frequency range		–	800	–	MHz
Output Level (PEP)		–	+33	–	dBm

C-BUS Interface

See CMX998 Datasheet

Notes:

2. PCB current consumption, not current consumption of the CMX998.
3. +32dBm is generally achieved with continuous operation; +33dBm can be achieved using burst transmission typical in TDMA systems.
4. Using TETRA $\pi/4$ -DQPSK modulation at 18ks/s, 18kHz measurement bandwidth for adjacent channel power.

CML does not assume any responsibility for the use of any circuitry described. No IPR or circuit patent licences are implied. CML reserves the right at any time without notice to change the said circuitry and any part of this product specification. Evaluation kits and demonstration boards are supplied for the sole purpose of demonstrating the operation of CML products and are supplied without warranty. They are intended for use in a laboratory environment only and are not for re-sale, end-use or incorporation into other equipments. Operation of these kits and boards outside a laboratory environment is not permitted within the European Community. All software/firmware is supplied "as is" and is without warranty. It forms part of the product supplied and is licensed for use only with this product, for the purpose of demonstrating the operation of CML products. Whilst all reasonable efforts are made to ensure that software/firmware contained in this product is virus free, CML accepts no responsibility whatsoever for any contamination which results from using this product and the onus for checking that the software/firmware is virus free is placed on the purchaser of this evaluation kit or development board.

 CML Microcircuits (UK) Ltd <small>COMMUNICATION SEMICONDUCTORS</small>	 CML Microcircuits (USA) Inc. <small>COMMUNICATION SEMICONDUCTORS</small>	 CML Microcircuits (Singapore) Pte Ltd <small>COMMUNICATION SEMICONDUCTORS</small>
Tel: +44 (0)1621 875500 Fax: +44 (0)1621 875600 Sales: sales@cmlmicro.com Tech Support: techsupport@cmlmicro.com	Tel: +1 336 744 5050 800 638 5577 Fax: +1 336 744 5054 Sales: us.sales@cmlmicro.com Tech Support: us.techsupport@cmlmicro.com	Tel: +65 67450426 Fax: +65 67452917 Sales: sg.sales@cmlmicro.com Tech Support: sg.techsupport@cmlmicro.com
- www.cmlmicro.com -		