

Features

- Full-Duplex Audio Processing
- On-Chip Filters
- Carrier Rejection >55dB
- Uses IF (10.24 MHz) Clock
- Excellent Audio Quality
- Low Power Operation (3.0V)
- Battery Powered Portability

Applications

- Cordless Telephones
- Wireless PBX
- Two-Way Radio
- Leisure Radio (FRS, GMRS, MURS, PMR446)

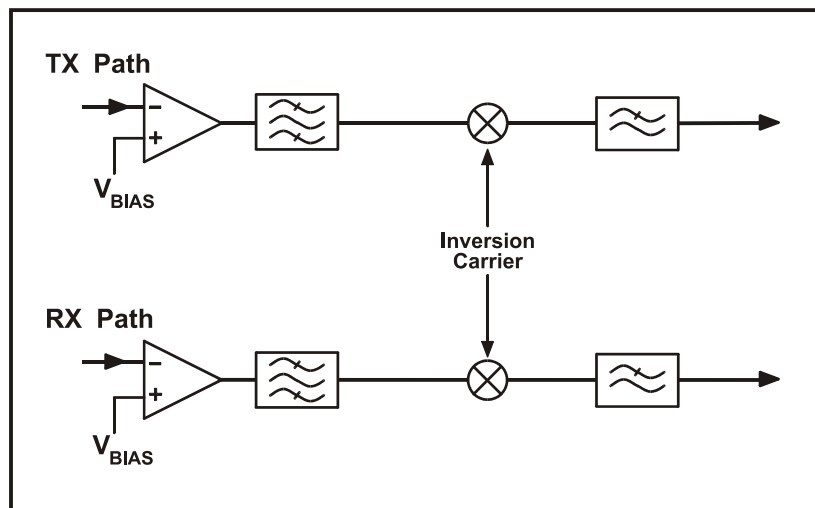

1.1 Brief Description

The FX/MX128 is a full-duplex frequency inversion scrambler designed to provide secure conversations. The Rx and Tx audio paths consist of the following:

1. A switched-capacitor balanced modulator with high baseband and carrier rejection.
2. A 3.3 kHz inversion carrier (injection tone).
3. A 3100 Hz lowpass filter.
4. Input op-amps with externally adjustable gain.

The FX/MX128 uses mixed signal CMOS switched-capacitor filter technology and operates from a single supply in the range of 3.0 to 5.5 volts. The inversion carrier's frequency and filter switching clock are generated on-chip using an external 10.24 MHz or 3.58/3.6864 MHz crystal or clock input (selectable).

This device is available in the following package styles: 16-pin SOIC, TSSOP and PDIP.

CONTENTS

Section	Page
1.2 Block Diagram	3
1.3 Signal List	4
1.4 External Components	5
1.5 Application	6
1.6 Application Notes	6
1.7 Performance Specification	7
1.7.1 Electrical Performance	7
1.7.2 Packaging.....	10

1.2 Block Diagram

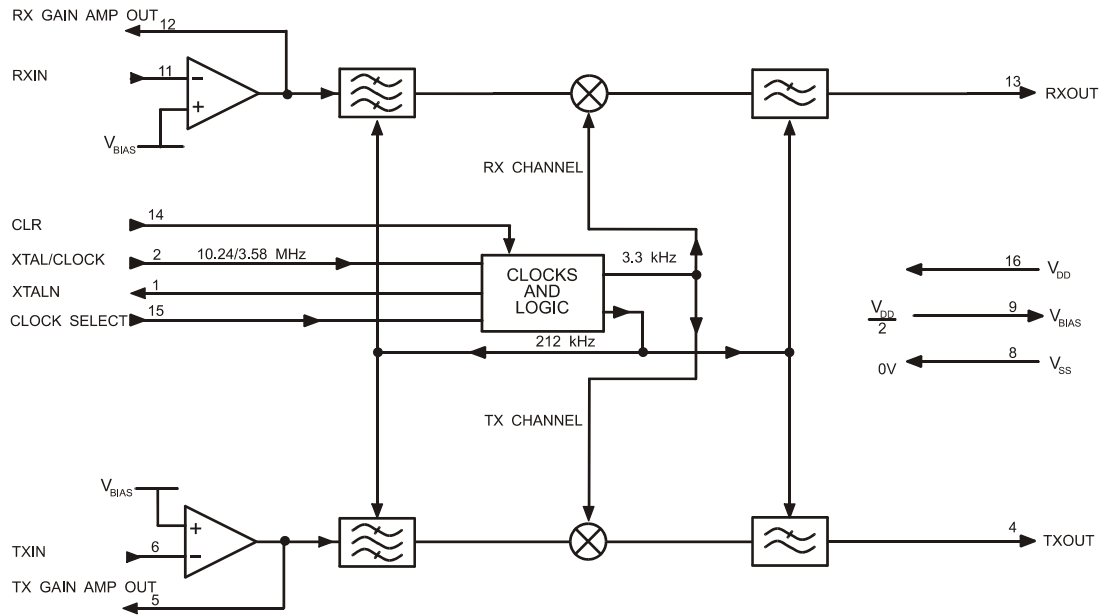

Figure 1: Block Diagram

1.3 Signal List

All Packages	Signal		Description
Pin No.	Name	Type	
1	XTALN	O/P	This is the output of the clock oscillator inverter.
2	XTAL/CLOCK	I/P	10.24 MHz, 3.58/3.6864 MHz, or an externally derived clock is injected at this pin. See Figure 1.
3	-	N/C	No connection should be made to this pin.
4	TXOUT	O/P	This is the analogue output of the transmit channel. It is internally biased at $V_{DD}/2$.
5	TX GAIN AMP OUT	O/P	This is the output pin of the transmit channel gain adjusting op-amp. See Figure 3 for gain setting components.
6	TXIN	I/P	This is the analogue signal input to the transmit channel. This input goes to a gain adjusting op-amp whose gain is set by external components. See Figure 3.
7	-	N/C	No connection should be made to this pin.
8	V_{SS}	Power	Negative supply (GND)
9	V_{BIAS}	O/P	This is an internally generated bias voltage output ($V_{DD}/2$). It should NOT be decoupled with a capacitor.
10	-	N/C	No connection should be made to this pin.
11	RXIN	I/P	This is the analogue signal input to the receive channel. This input goes to a gain adjusting op-amp whose gain is set by external components. See Figure 3.
12	RX GAIN AMP OUT	O/P	This is the output pin of the receive channel gain adjusting op-amp. See Figure 3 for gain setting components.
13	RXOUT	O/P	This is the analogue output of the receive channel. It is internally biased at $V_{DD}/2$.
14	CLR	I/P	A logic 1 on this input selects the invert mode. A logic 0 selects the clear (not inverted) mode.
15	CLOCK SELECT	I/P	Selects either 10.24 or 3.58/3.6864 MHz clock frequency. A logic "1" selects 10.24 MHz, and a logic "0" selects 3.58/3.6864 MHz. This input is internally pulled high.
16	V_{DD}	Power	Positive supply of 3.0V to 5.5 V

Notes:

I/P = Input
O/P = Output
N/C = No Connection

1.4 External Components

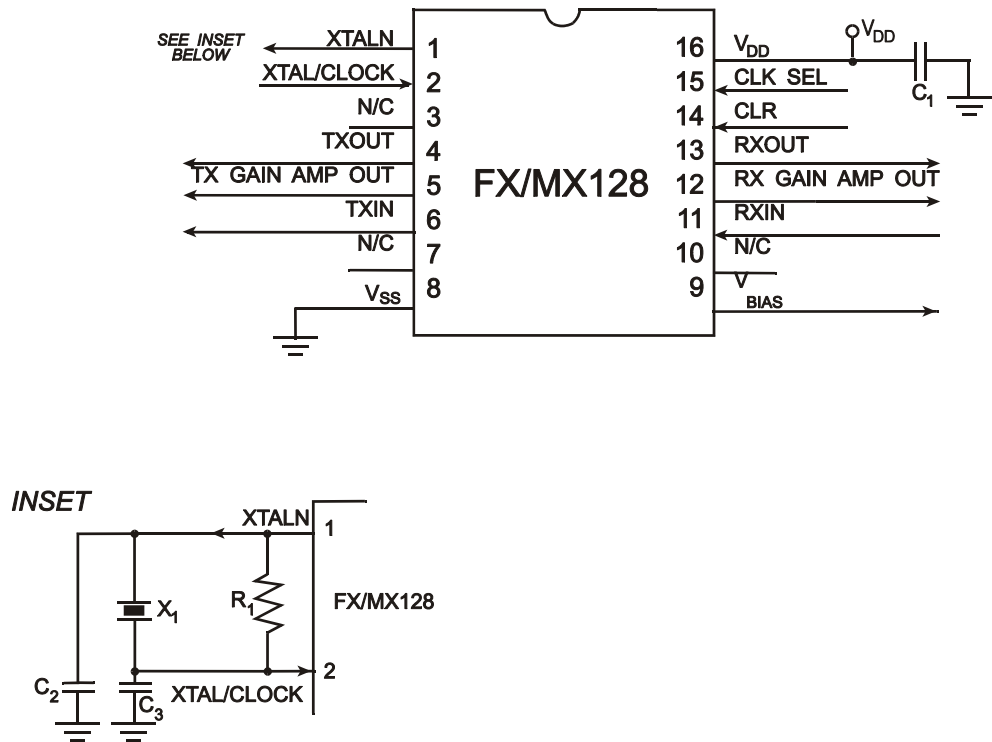

Components	Value	Value
X1	10.24MHz	3.58/3.6864 MHz
R1	1.0MΩ	1.0MΩ
C1	0.47μF	0.47μF
C2	22.0pF	33.0pF
C3	22.0pF	47.0pF

Note: Xtal circuitry shown is in accordance with CML's Xtal Application Note.

Figure 2: Recommended External Components

1.5 Application

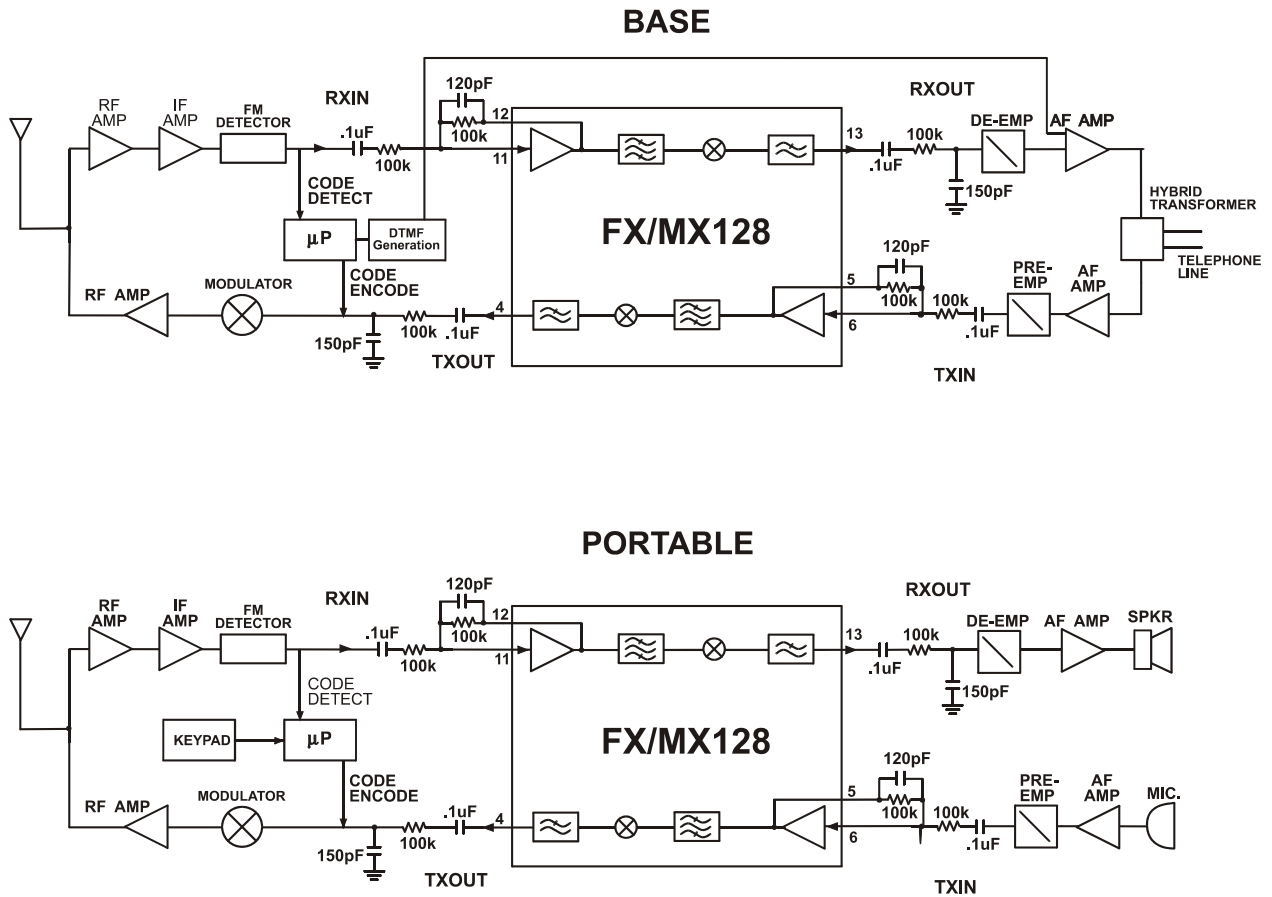

Note: Components shown set a gain of 0dB.

Figure 3: Block Diagram of a Typical Application of the FX/MX128 (Cordless Phone)

1.6 Application Notes

Formulae for calculating the carrier frequency, upper cutoff frequency and lower cutoff frequency with clock select pin high are as follows:

- Carrier Frequency = (3.2995kHz / 10.24MHz) * XTAL frequency
- Upper Cutoff Frequency = (2.800kHz / 10.24MHz) * XTAL frequency
- Lower Cutoff Frequency = (400Hz / 10.24MHz) * XTAL frequency

Formulae for calculating the carrier frequency, upper cutoff frequency and lower cutoff frequency with clock select pin low are as follows:

- Carrier Frequency = (3.2995kHz / 3.415MHz) * XTAL frequency
- Upper Cutoff Frequency = (2.800kHz / 3.415MHz) * XTAL frequency
- Lower Cutoff Frequency = (400Hz / 3.415MHz) * XTAL frequency

1.7 Performance Specification

1.7.1 Electrical Performance

Absolute Maximum Ratings

Exceeding these maximum ratings can result in damage to the device.

General	Min.	Max.	Units
Supply ($V_{DD} - V_{SS}$)	-0.3	7.0	V
Voltage on any pin to V_{SS}	-0.3	$V_{DD} + 0.3$	V
Current in or out V_{DD} and V_{SS} pins	-30	+30	mA
Current in or out of any other pin	-20	+20	mA

E4/P3/D4 Packages	Min.	Max.	Units
Total Device Dissipation (P3 and D4) at $T_{AMB} = 25^{\circ}\text{C}$	—	1000	mW
...Derating (P3 and D4)	—	13	mW/ $^{\circ}\text{C}$
Total Device Dissipation (E4) at $T_{AMB} = 25^{\circ}\text{C}$	—	400	mW
...Derating (E4)	—	5.3	mW/ $^{\circ}\text{C}$
Storage Temperature	-55	+125	$^{\circ}\text{C}$
Operating Temperature	-40	+85	$^{\circ}\text{C}$

Operating Limits

Correct operation of the device outside these limits is not implied.

	Min.	Max.	Units
Supply ($V_{DD} - V_{SS}$)	3.0	5.5	V
Operating Temperature	-40	+85	$^{\circ}\text{C}$
Clock Frequency	—	10.24	MHz

Operating Characteristics

For the following conditions unless otherwise specified:

$V_{DD} = 3.3V$ at $T_{AMB} = 25^{\circ}C$

Clock Frequency = 10.24MHz

Audio Level 0dB ref. at 1kHz = $(V_{DD}-1) \times 150mV_{RMS}$ e.g. $V_{DD} = 3.3V$ 0dB = $345mV_{RMS}$.

	Notes	Min.	Typ.	Max	Units
Static Values					
Supply Current		—	2.0	3.0	mA
Input Impedance					
Digital	2	100	—	—	k Ω
Amplifiers	2	1.0	10.0	—	M Ω
Output Impedance (RXOUT, TXOUT)		—	1.0	—	k Ω
Input Logic 1 Voltage	1	70%	—	—	V_{DD}
Input Logic 0 Voltage	1	—	—	30%	V_{DD}
Dynamic Values					
General					
Analogue Signal Input Levels	3	-16.0	—	3	dB
Analogue Output Noise	3,4	—	2.5	5.0	mV_{RMS}
Clear Mode					
Passband -3dB Cutoff Frequencies					
Low	3	—	—	300	Hz
High	3	3000	—	—	Hz
Passband Ripple (300-3000Hz)					
Rx Channel	3	0	—	3.6	dB
Tx Channel	3	0	—	2.9	dB
Passband Ripple (500-2750Hz)					
Rx Channel	3	0	—	2.2	dB
Tx Channel	3	0	—	2.0	dB
Filter Attenuation at 3.3 kHz					
Rx and Tx Channel	3	—	30	—	dB
Filter Attenuation at 3.6 kHz					
Rx and Tx Channel	3	—	45	—	dB

	Notes	Min.	Typ.	Max	Units
Passband Gain (@1kHz ref.)					
Rx and Tx Channel	3	-1.5	—	0.5	dB
Switched-Capacitor Filter Sampling		—	211.066	—	kHz
Carrier Frequency		—	3298	—	Hz
Invert Mode Combined Tx and Rx Response					
Passband -3dB Cutoff Frequencies					
Low	3	—	—	400	Hz
High	3	2800	—	—	Hz
Passband Gain	3	-3	—	0.5	dB
Distortion (@1kHz)	3	—	1.75	2.75	%
Passband Gain (@1kHz ref.)	3,5	-2.5	-1.5	0	dB
Low Frequency Roll-off (<200 Hz)	3	12	—	—	dB/oct.
Invert Mode Single Channel Response					
Unwanted Modulation Products					
Rx and Tx Channel	2	—	-40	—	dB
Carrier Breakthrough					
Rx and Tx Channel	2	—	-55	—	dB
Baseband Breakthrough					
Rx and Tx Channel	2	—	-40	—	dB

Operating Characteristics Notes:

1. Batch sampled only
2. By characterisation only
3. Includes the combined effects of an external single pole anti-alias (low pass) input filter and an external single pole reconstruction (low pass) output filter, each having a corner frequency of 10kHz. See Figure 3 for an example circuit.
4. Short circuit Rx or Tx input, measure noise at corresponding analogue output, in 30kHz bandwidth
5. Op Amp gain 0dB
6. Clear mode only

1.7.2 Packaging

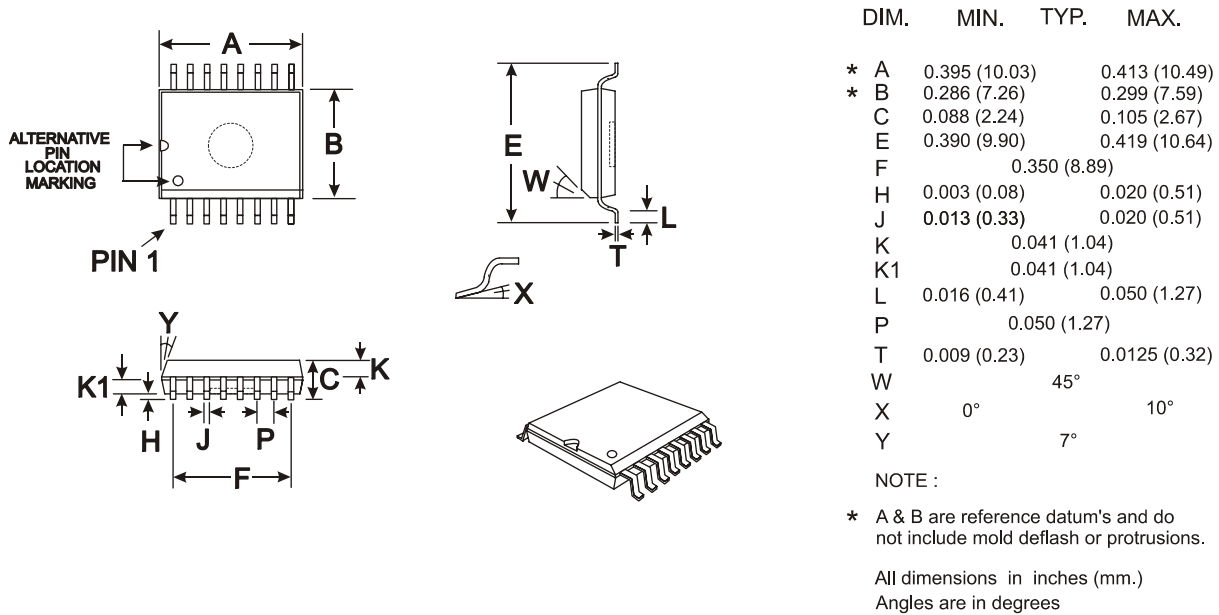

Figure 4: 16-pin SOIC Mechanical Outline: Order as part no. FX128D4 or MX128DW

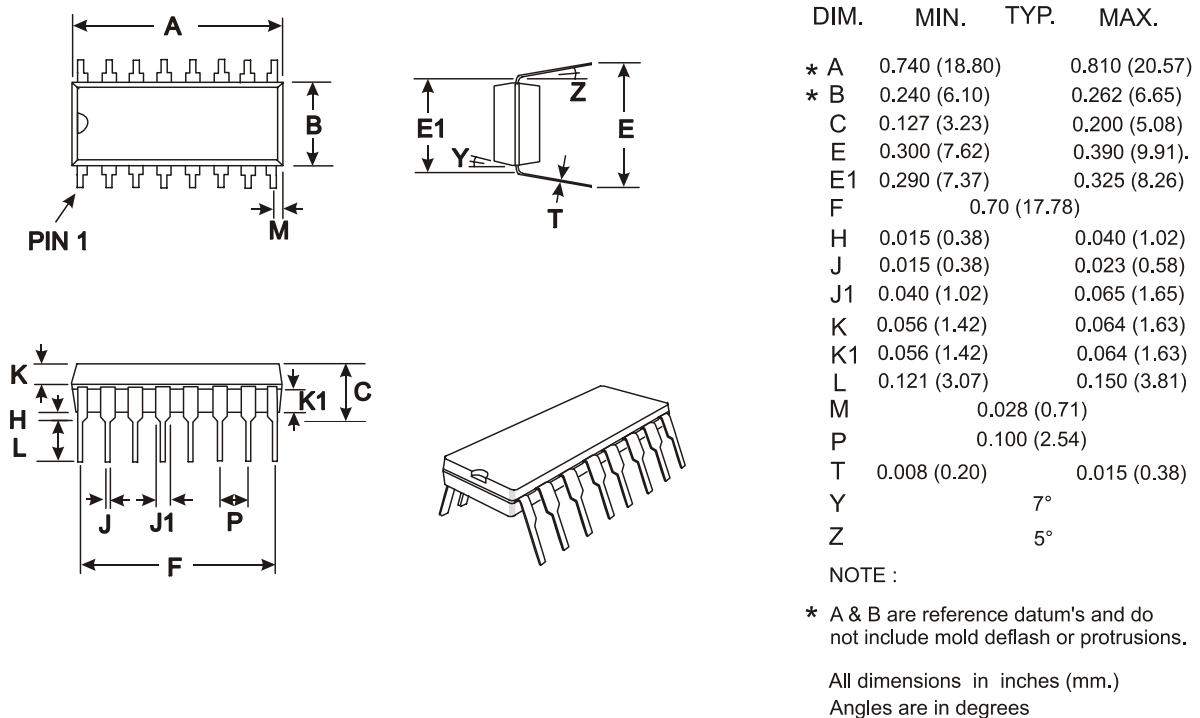

Figure 5: 16-pin PDIP Mechanical Outline: Order as part no. FX128P3 or MX128P

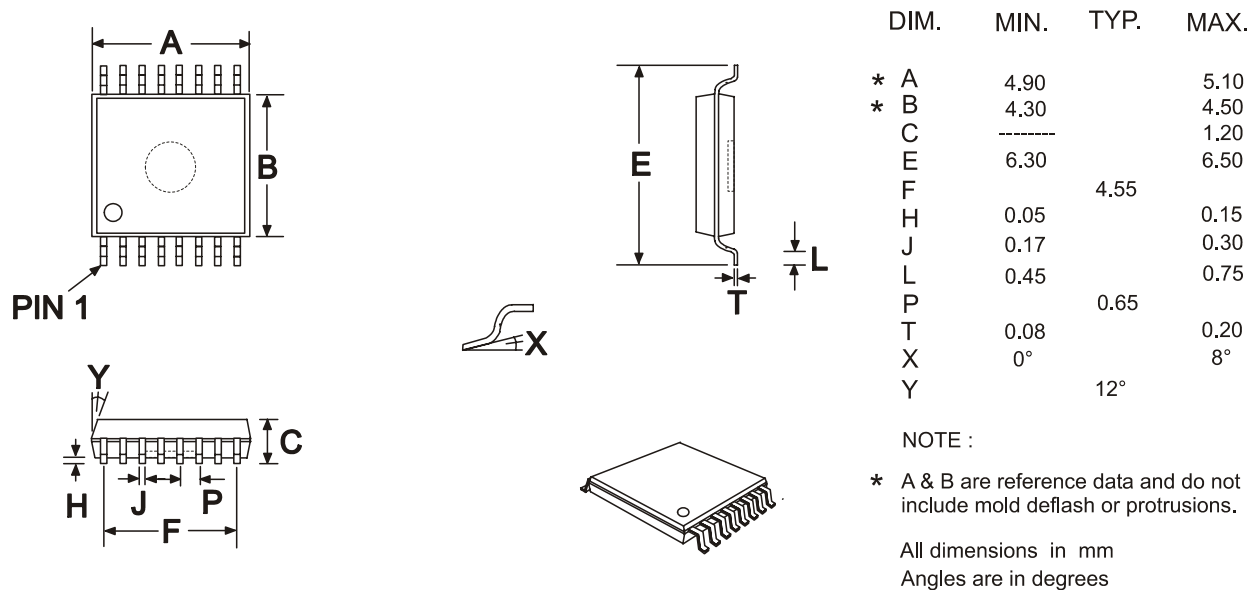

Figure 6: 16-pin TSSOP Mechanical Outline: Order as part no. FX128E4 or MX128E4



Handling precautions: This product includes input protection, however, precautions should be taken to prevent device damage from electro-static discharge. CML does not assume any responsibility for the use of any circuitry described. No IPR or circuit patent licences are implied. CML reserves the right at any time without notice to change the said circuitry and this product specification. CML has a policy of testing every product shipped using calibrated test equipment to ensure compliance with this product specification. Specific testing of all circuit parameters is not necessarily performed.

www.cmlmicro.com

For FAQs see: www.cmlmicro.com/products/faqs/

For a full data sheet listing see: www.cmlmicro.com/products/datasheets/download.htm

For detailed application notes: www.cmlmicro.com/products/applications/

 <p>CML Microcircuits (UK) Ltd COMMUNICATION SEMICONDUCTORS</p>	 <p>CML Microcircuits (USA) Inc. COMMUNICATION SEMICONDUCTORS</p>	 <p>CML Microcircuits (Singapore) Pte Ltd COMMUNICATION SEMICONDUCTORS</p>	
<p>Oval Park, Langford, Maldon, Essex, CM9 6WG - England.</p> <p>Tel: +44 (0)1621 875500 Fax: +44 (0)1621 875600</p> <p>Sales: sales@cmlmicro.com</p> <p>Technical Support: techsupport@cmlmicro.com</p>	<p>4800 Bethania Station Road, Winston-Salem, NC 27105 - USA.</p> <p>Tel: +1 336 744 5050, 800 638 5577 Fax: +1 336 744 5054</p> <p>Sales: us.sales@cmlmicro.com</p> <p>Technical Support: us.techsupport@cmlmicro.com</p>	<p>No 2 Kallang Pudding Road, #09 to 05/06 Mactech Industrial Building, Singapore 349307</p> <p>Tel: +65 6745 0426 Fax: +65 6745 2917</p> <p>Sales: sg.sales@cmlmicro.com</p> <p>Technical Support: sg.techsupport@cmlmicro.com</p>	<p>No. 218, Tian Mu Road West, Tower 1, Unit 1008, Shanghai Kerry Everbright City, Zhabei, Shanghai 200070, China.</p> <p>Tel: +86 21 6317 4107 +86 21 6317 8916 Fax: +86 21 6317 0243</p> <p>Sales: cn.sales@cmlmicro.com.cn</p> <p>Technical Support: sg.techsupport@cmlmicro.com</p>