

# CML Semiconductor Products

## Bell 202 Compatible Modem **FX614**

D/614/4 October 1997  
Advance Information

### 1.0 Features

- 1200bits/sec 1/2 Duplex Bell 202 compatible Modem with:
  - Optional 5bits/sec and 150bits/sec Back Channel
  - Optional 1200bits/sec Data Retiming Facility
  - 3.0 to 5.5V Supply; 1.0mA at 3V 'Zero-Power' Mode; 1 $\mu$ A
  - Optional Line Equalisation
  - -40°C to +85°C Operating Temperature
  - 16-pin SOIC and DIL Packages
  - 3.58MHz Xtal/Clock Rate

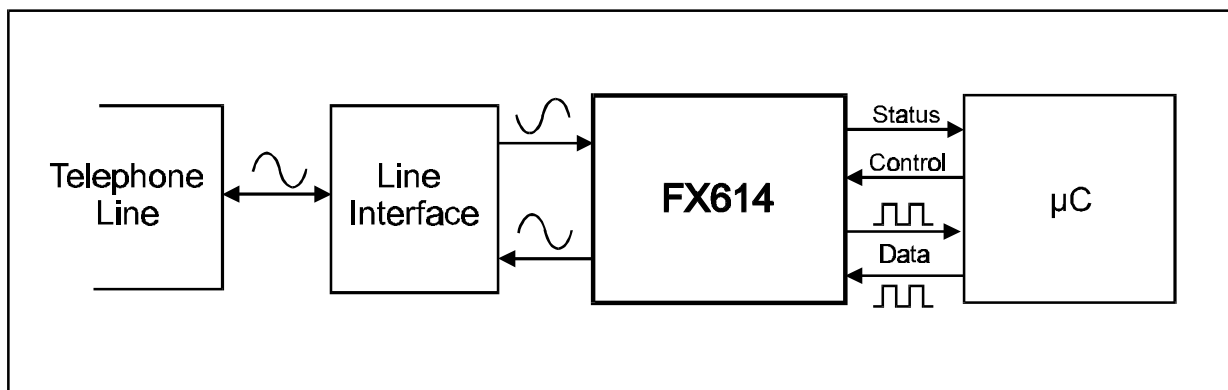

### 1.1 Brief Description

The FX614 is a low power CMOS integrated circuit for the reception or transmission of asynchronous 1200bits/sec data and is suitable for use in Bell 202 type systems. It is also capable of generating the 5bits/sec or 150bits/sec 'back channel'.

The device incorporates an optional Tx and Rx data retiming function that removes the need for a UART in the associated  $\mu$ C when operating at 1200bits/sec. An optional line equaliser is incorporated into the receive path, this is controlled by an external logic level.

The FX614 may be used in a wide range of telephone telemetry systems. With a low operating voltage of 3.0V, a very low current 'sleep' mode (1 $\mu$ A) and an operating current of 1mA the device is ideal for portable, terminal and line powered applications. A 3.58MHz standard Xtal/Clock rate is required and the device operates from a 3.0V to 5.5V supply. Both SOIC (D4) and Plastic DIL (P3) 16-pin package types are available.

**CONTENTS**

<u>Section</u>	<u>Page</u>
<b>1.0 Features .....</b>	<b>1</b>
<b>1.1 Brief Description.....</b>	<b>1</b>
<b>1.2 Block Diagram .....</b>	<b>3</b>
<b>1.3 Signal List.....</b>	<b>3</b>
<b>1.4 External Components.....</b>	<b>5</b>
<b>1.5 General Description.....</b>	<b>5</b>
<b>1.5.1 Xtal Osc and Clock Dividers .....</b>	<b>5</b>
<b>1.5.2 Mode Control Logic .....</b>	<b>6</b>
<b>1.5.3 Rx Input Amplifier .....</b>	<b>6</b>
<b>1.5.4 Receive Filter and Equaliser.....</b>	<b>6</b>
<b>1.5.5 Energy Detector .....</b>	<b>7</b>
<b>1.5.6 FSK Demodulator.....</b>	<b>7</b>
<b>1.5.7 FSK Modulator and Transmit Filter .....</b>	<b>7</b>
<b>1.5.8 Rx Data Retiming .....</b>	<b>9</b>
<b>1.5.9 Tx Data Retiming.....</b>	<b>10</b>
<b>1.6 Application Notes .....</b>	<b>12</b>
<b>1.6.1 Line Interface.....</b>	<b>12</b>
<b>1.7 Performance Specification.....</b>	<b>13</b>
<b>1.7.1 Electrical Performance.....</b>	<b>13</b>
<b>1.7.2 Packaging.....</b>	<b>16</b>

### 1.2 Block Diagram

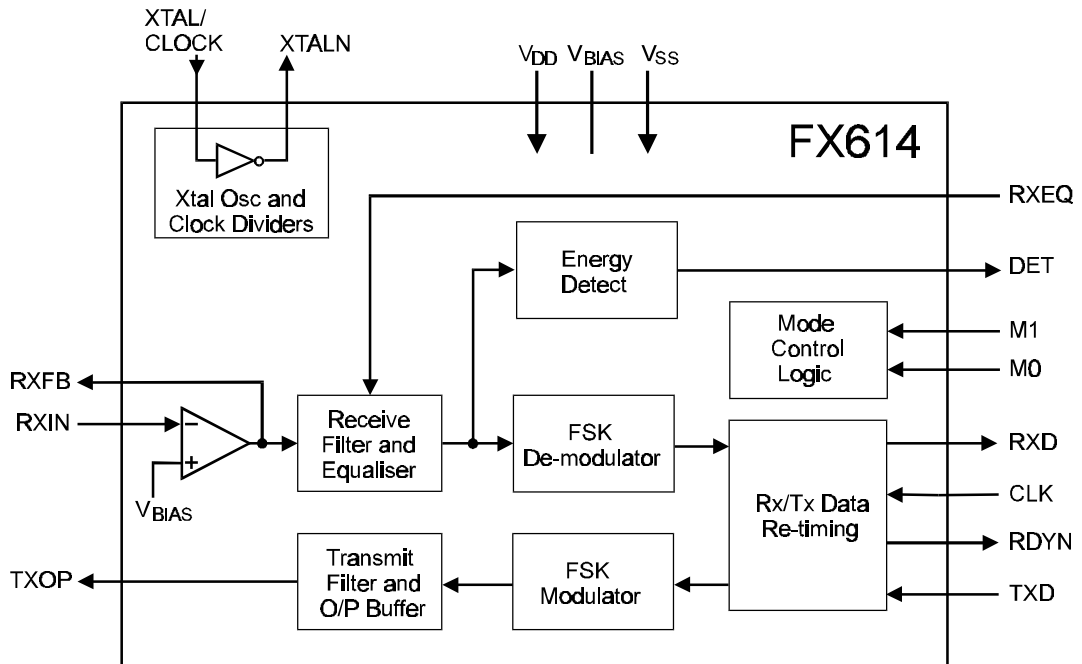

Figure 1 Block Diagram

### 1.3 Signal List

FX614 D4/P3	Signal		Description
Pin No.	Name	Type	
1	XTALN	O/P	The output of the on-chip Xtal oscillator inverter.
2	XTAL/CLOCK	I/P	The input to the on-chip Xtal oscillator inverter.
3	M0	I/P	A logic level input for setting the mode of the device. See section 1.5.2.
4	M1	I/P	A logic level input for setting the mode of the device. See section 1.5.2.
5	RXIN	I/P	Input to the Rx input amplifier.
6	RXFB	O/P	Output of the Rx input amplifier, and the input to the Rx filter.
7	TXOP	O/P	The output of the FSK generator.
8	V <sub>SS</sub>	Power	The negative supply rail (ground).

FX614 D4/P3	Signal		Description
Pin No.	Name	Type	
9	V <sub>BIAS</sub>	O/P	Internally generated bias voltage, held at V <sub>DD</sub> /2 when the device is not in 'Zero-Power' mode. Should be decoupled to V <sub>SS</sub> by a capacitor mounted close to the device pins.
10	RXEQ	I/P	A logic level input for enabling/disabling the equaliser in the receive filter. See section 1.5.4.
11	TXD	I/P	A logic level input for either the raw input to the FSK Modulator or data to be re-timed depending on the state of the M0, M1 and CLK inputs. See section 1.5.9.
12	CLK	I/P	A logic level input which may be used to clock data bits in or out of the FSK Data Retiming block.
13	RXD	O/P	A logic level output carrying either the raw output of the FSK Demodulator or re-timed characters depending on the state of the M0, M1 and CLK inputs. See section 1.5.8.
14	DET	O/P	A logic level output of the on-chip Energy Detect circuit.
15	RDYN	O/P	"Ready for data transfer" output of the on-chip data retiming circuit. This open-drain active low output may be used as an Interrupt Request/Wake-up input to the associated $\mu$ C. An external pull-up resistor should be connected between this output and V <sub>DD</sub> .
16	V <sub>DD</sub>	Power	The positive supply rail. Levels and thresholds within the device are proportional to this voltage. Should be decoupled to V <sub>SS</sub> by a capacitor mounted close to the device pins.

**Notes:** I/P = Input  
O/P = Output

This device is capable of detecting and decoding small amplitude signals. To achieve this V<sub>DD</sub> and V<sub>BIAS</sub> decoupling and protecting the receive path from extraneous in-band signals are very important. It is recommended that the decoupling capacitors are placed so that connections between them and the device pins are as short as practicable. A ground plane protecting the receive path will help attenuate interfering signals.

### 1.4 External Components

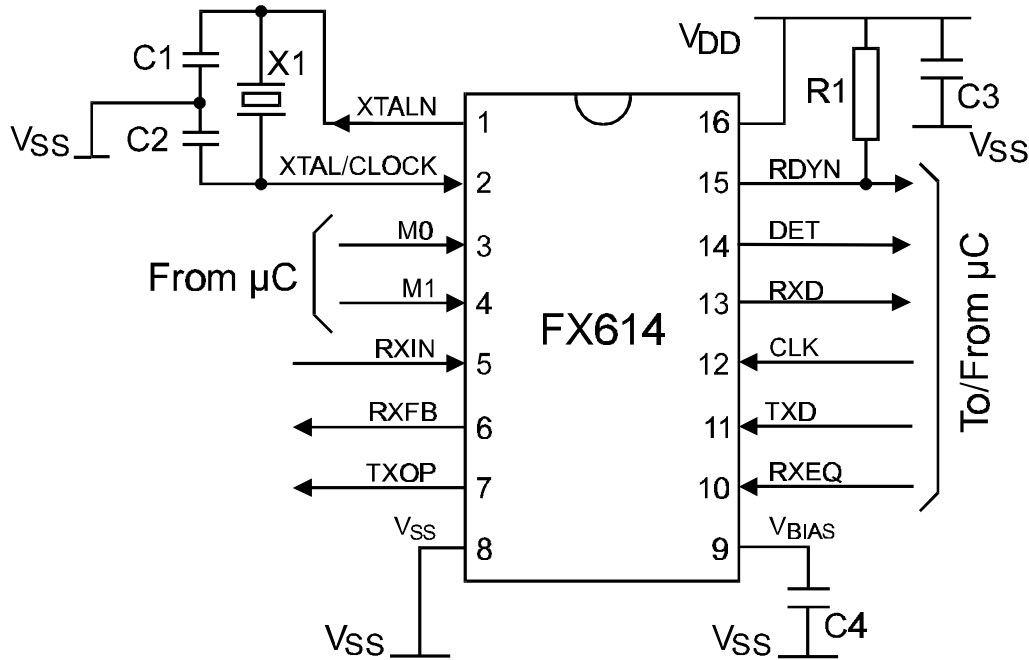

R1	100kΩ	C1, C2	18pF
X1	3.579545MHz	C3	0.1µF
		C4	0.1µF

Resistors ±5%, capacitors ±10% unless otherwise stated.

**Figure 2 Recommended External Components for Typical Application**

### 1.5 General Description

#### 1.5.1 Xtal Osc and Clock Dividers

Frequency and timing accuracy of the FX614 is determined by a 3.579545MHz clock present at the XTAL/CLOCK pin. This may be generated by the on-chip oscillator inverter using the external components C1, C2 and X1 of Figure 2, or may be supplied from an external source to the XTAL/CLOCK input. If supplied from an external source, C1, C2 and X1 should not be fitted.

The on-chip oscillator is turned off in the 'Zero-Power' mode.

If the clock is provided by an external source which is not always running, then the 'Zero-Power' mode must be set when the clock is not available. Failure to observe this rule may cause a significant rise in the supply current drawn by FX614 as well as generating undefined states of the RXD, DET and RDYN outputs.

### 1.5.2 Mode Control Logic

The FX614's operating mode is determined by the logic levels applied to the M0 and M1 input pins:

M1	M0	Rx Mode	Tx Mode	Data Retime <sup>[1]</sup>
0	0	1200bits/sec	150bits/sec	Rx
0	1	Off	1200bits/sec	Tx
1	0	1200bits/sec	Off / 5bits/sec	Rx
1	1	'Zero-Power'		-

[1] If enabled.

In the 'Zero-Power' (ZP) mode, power is removed from all internal circuitry. When leaving the 'ZP' mode there must be a delay of 20ms before any Tx data is passed to, or Rx data read from, the device to allow the bias level, filters and oscillator to stabilise. On applying power to the device the mode must be set to 'ZP', i.e. M0 = '1', M1 = '1', until  $V_{DD}$  has stabilised.

### 1.5.3 Rx Input Amplifier

This amplifier is used to adjust the received signal to the correct amplitude for the FSK receiver and Energy Detect circuits (see section 1.6.1).

### 1.5.4 Receive Filter and Equaliser

Is used to attenuate out of band noise and interfering signals, especially the locally generated transmit tones which might otherwise reach the 1200bits/sec FSK Demodulator and Energy Detector circuits. This block also includes a switchable equaliser section. When the RXEQ pin is low, the overall group delay of the receive filter is flat over the 1200bits/sec frequency range. If the RXEQ pin is high the receive filter's typical overall group delay will be as shown in Figure 3.

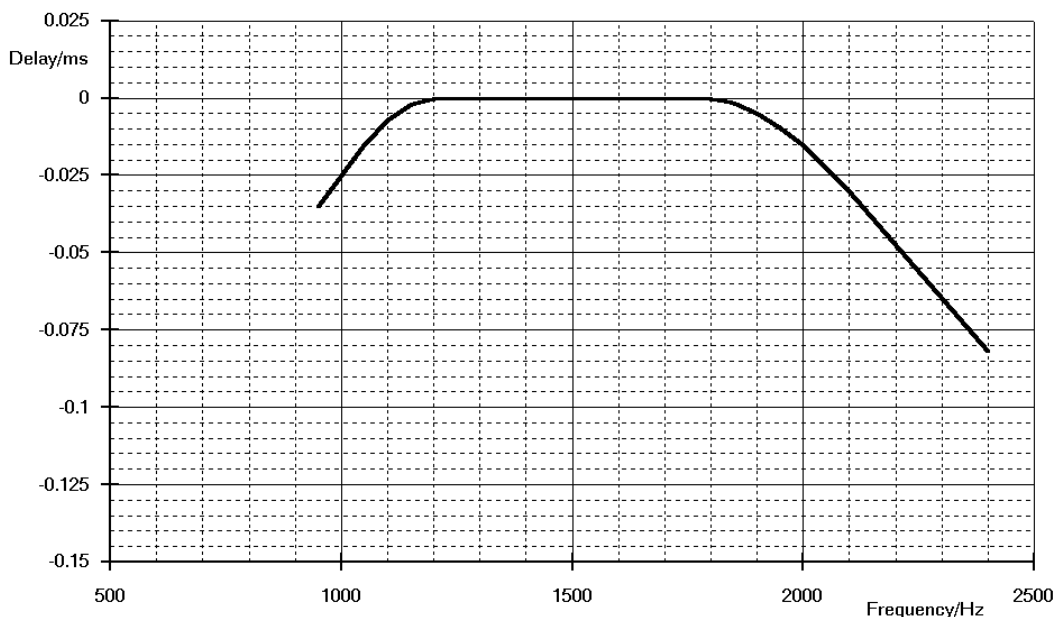

Figure 3 Rx Equaliser Group Delay (RXEQ = '1') wrt 1700Hz

### 1.5.5 Energy Detector

This block operates by measuring the level of the signal at the output of the Receive Filter, and comparing it against a preset threshold.

The DET output will be set high when the level has exceeded the threshold for sufficient time. Amplitude and time hysteresis are used to reduce chattering of the DET output in marginal conditions.

Note that this circuit may also respond to non-FSK signals such as speech.

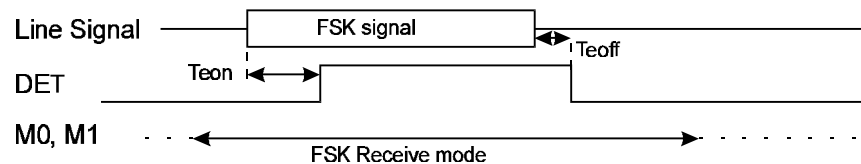

See section 1.7.1 for definitions of Teon and Teoff

**Figure 4 FSK Level Detector Operation**

### 1.5.6 FSK Demodulator

This block converts the 1200bits/sec FSK input signal to a logic level received data signal which is output via the RXD pin as long as the Data Retiming function is not enabled (see section 1.5.8). This output does not depend on the state of the DET output.

When the Rx 1200bits/sec mode is 'Off' or in 'ZP' the DET and RXD pins are held low.

Note that in the absence of a valid FSK signal, the demodulator may falsely interpret speech or other extraneous signals as data. For this reason it is advised that the RXD pin is read only when data is expected.

### 1.5.7 FSK Modulator and Transmit Filter

These blocks produce a tone according to the TXD, M0 and M1 inputs as shown in the table below, assuming data retiming is not being used:

M1	M0	TXD = '0'	TXD = '1'
1	1	-	-
1	0	0Hz <sup>[1]</sup>	387Hz
0	0	487Hz	387Hz
0	1	2200Hz	1200Hz

Note: [1] TXOP held at approx  $V_{DD}/2$ .

When modulated at the appropriate baud rates, the Transmit Filter and associated external components (see section 1.6.1) limit the FSK out of band energy sent to the line in accordance with Figures 5a and 5b, assuming that the signal on the line is at -6dBm or less.

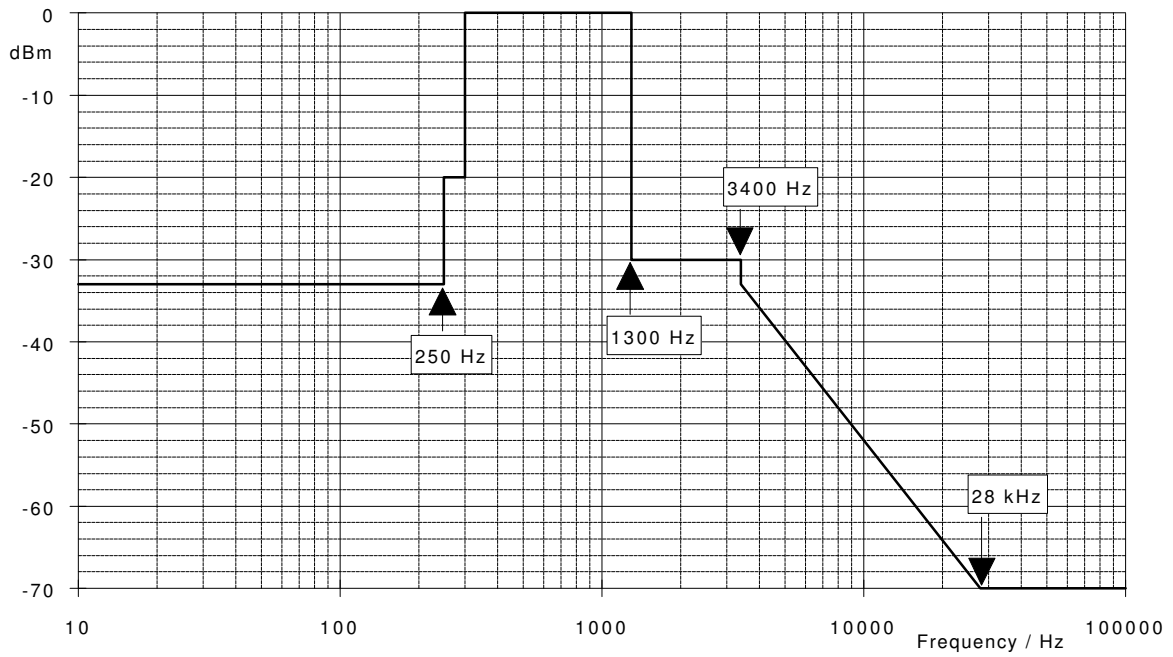

Figure 5a Tx limits at 5bits/sec or 150bits/sec rate

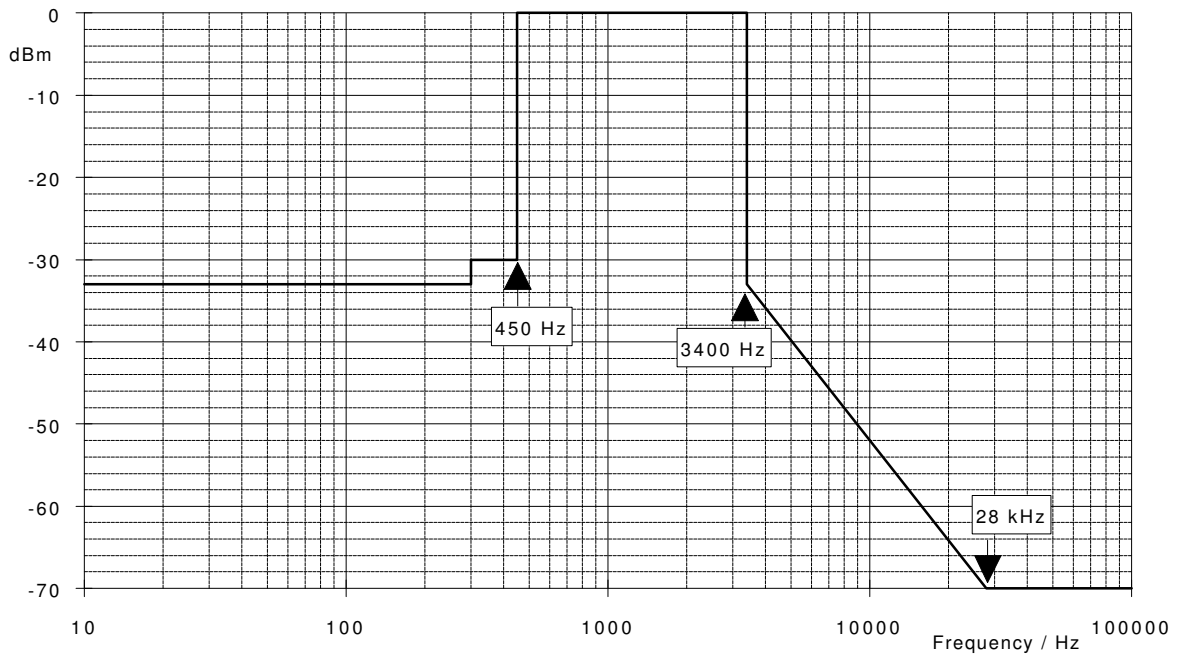

Figure 5b Tx limits at 1200bits/sec rate



### 1.5.8 Rx Data Retiming

This function may be used when the received data consists of 1200bits/sec asynchronous characters, each character consisting of one start bit followed by a minimum of 9 formatted bits as shown in the table below.

Data bits	Parity bits	Stop bits
7	0	>=2
7	1	>=1
8	0	>=1
8	1	>=1
9	0	>=1

The Data Retiming block, when enabled in receive mode, extracts the first 9 bits of each character following the start bit from the received asynchronous data stream, and presents them to the  $\mu$ C under the control of strobe pulses applied to the CLK input. The timing of these pulses is not critical and they may easily be generated by a simple software loop. This facility removes the need for a UART in the  $\mu$ C without incurring an excessive software overhead.

The receive retiming block consists of two 9-bit shift registers, the input of the first is connected to the output of the FSK demodulator and the output of the second is connected to the RXD pin. The first register is clocked by an internally generated signal that stores the 9 received bits following the timing reference of a high to low transition at the output of the FSK demodulator. When the 9th bit is clocked into the first register these 9 bits are transferred to the second register, a new stop-start search is initiated and the CLK input is sampled. If the CLK input is low at this time the RDYN pin is pulled low and the first received bit is output on the RXD pin. The CLK pin should then be pulsed high 9 times, the first 8 high to low transitions will be used by the device to clock out the bits in the second register. The RDYN output is cleared the first time the CLK input goes high. At the end of the 9th pulse the RXD pin will be connected to the FSK demodulator output.

So to use the Data Retiming function, the CLK input should be kept low until the RDYN output goes low; if the Data Retiming function is not required the CLK input should be kept high at all times.

The only restrictions on the timing of the CLK waveform are those shown in Figure 6a and the need to complete the transfer of all nine bits into the  $\mu$ C within the time of a complete character at 1200bits/sec.

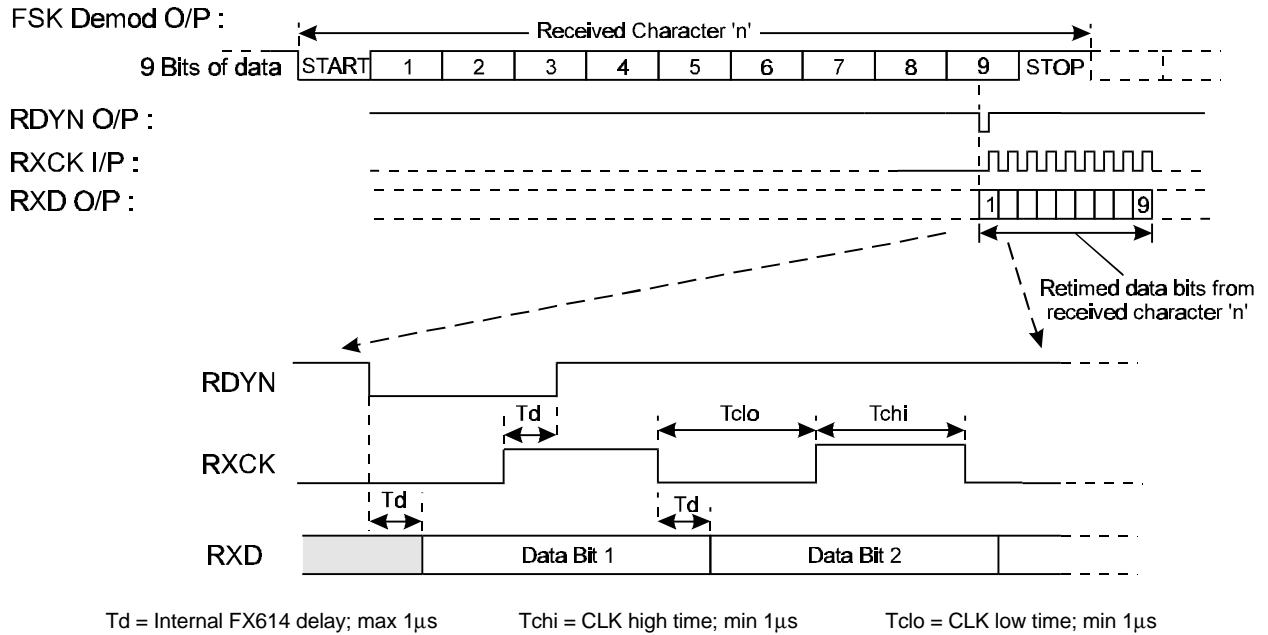

**Figure 6a FSK Operation with Rx Data Retiming**

Note that, if enabled, the Data Retiming block may interpret speech or other signals as random characters.

If the Data Retiming facility is not required, the CLK input to the FX614 should be kept high at all times. The asynchronous data from the FSK Demodulator will then be connected directly to the RXD output pin, and the RDYN output will not be activated by the FSK signal. This case is illustrated by the example in Figure 6b.

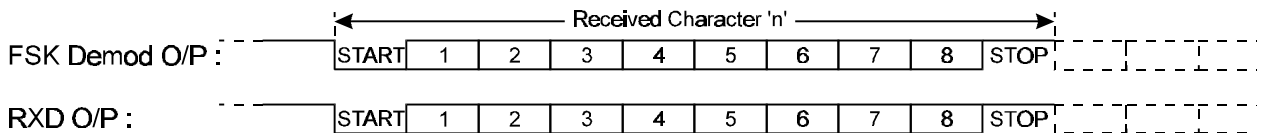

**Figure 6b FSK Operation without Rx Data Retiming (CLK always high)**

### 1.5.9 Tx Data Retiming

The Data Retiming block, when enabled in 1200bits/sec transmit mode, requires the controlling µC to load one bit at a time into the device by a pulse applied to the CLK input. The timing of this pulse is not critical and it may easily be generated by a simple software loop. This facility removes the need for a UART in the µC without incurring an excessive software overhead.

The Tx re-timing circuit consists of two 1-bit registers in series, the input of the first is connected to the TXD pin and the output of the second feeds the FSK modulator. The second register is clocked by an internally generated 1200Hz signal and when this occurs the CLK input is sampled. If the CLK input is high the TXD pin directly controls the FSK modulator, if the CLK input is low the FSK modulator is controlled by the output of the second register and the RDYN pin is pulled low. The RDYN output is reset by a high level on the CLK input pin. A low to high change on the CLK input pin will latch the data from the TXD input pin into the first register ready for transfer to the second register when the internal 1200Hz signal next occurs.

So to use the retiming option the CLK input should be held low until the RDYN output is pulled low. When the RDYN pin goes low the next data bit should be applied at the TXD input and the CLK input pulled high and then low within the time limits set out in Figure 6c.

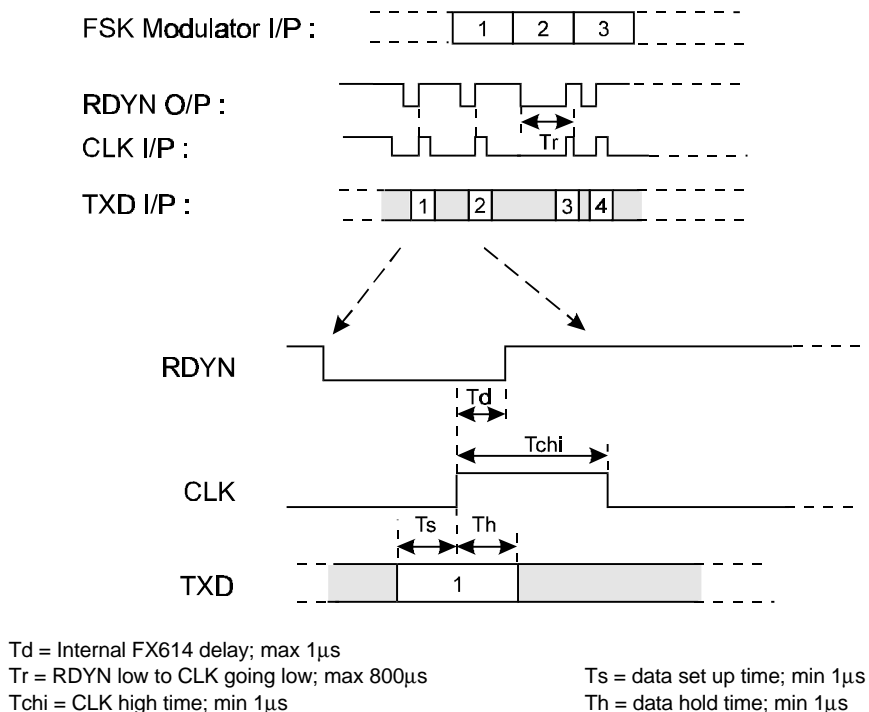

**Figure 6c FSK Operation with Tx Data Retiming**

To ensure synchronisation between the controlling device and the FX614 when entering Tx retiming mode the TXD pin must be held at a constant logic level from when the CLK pin is first pulled low to the end of loading in the second retimed bit. Similarly when exiting Tx retiming mode the TXD pin should be held at the same logic level as the last retimed bit for at least 2 bit times after the CLK line is pulled high.

If the data retiming facility is not required, the CLK input to the FX614 should be kept high at all times. The asynchronous data to the FSK modulator will then be connected directly to the TXD input pin. This is illustrated in Figure 6d and will also be the case when transmitting 5bits/sec or 150bits/sec data which have no retime option.

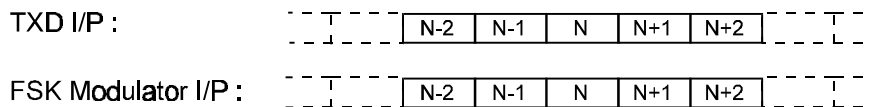

**Figure 6d FSK Operation without Tx Data Retiming (CLK always high)**

## 1.6 Application Notes

### 1.6.1 Line Interface

The signals on the telephone line are not suitable for direct connection to the FX614. A Line Interface circuit is necessary to:

- Provide high voltage and dc isolation
- Attenuate the Tx signal present at the Rx input
- Provide the low impedance drive necessary for the line
- Filter the Tx and Rx signals

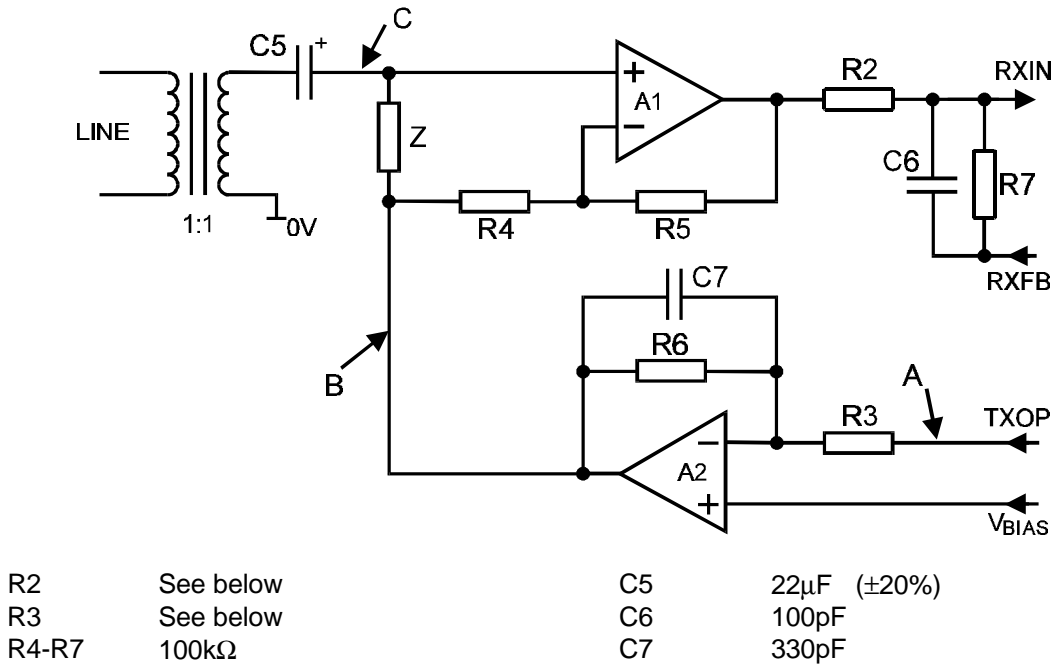

Resistors  $\pm$ 1%, capacitors  $\pm$ 10% unless otherwise stated.

**Figure 7 Line Interface Circuit**

Notes:

- The components 'Z' between points B and C should match the line impedance.
- Device A2 must be able to drive 'Z' and the line.
- R2: For optimum results R2 should be set so that the gain is  $V_{DD}/5.0$ , i.e.  $R2 = 100k\Omega$  at  $V_{DD} = 5.0V$ , rising to  $150k\Omega$  at  $V_{DD} = 3.3V$ .
- R3: The levels in dB (relative to a 775mV rms signal) at 'A', 'B' and 'C' in the line interface circuit are:
 

Level at	'A' = $20\text{Log}(V_{DD}/5)$
"	'B' = 'A' + $20\text{Log}(100k\Omega/R3)$
"	'C' = 'B' - 6

Example:

V <sub>DD</sub>	'A'	R3	'B'	'C'
3.3V	-3.6dB	100k $\Omega$	-3.6dB	-9.6dB
5.0V	0dB	150k $\Omega$	-3.5dB	-9.5dB

## 1.7 Performance Specification

### 1.7.1 Electrical Performance

#### Absolute Maximum Ratings

Exceeding these maximum ratings can result in damage to the device.

	Min.	Max.	Units
Supply ( $V_{DD} - V_{SS}$ )	-0.3	7.0	V
Voltage on any pin to $V_{SS}$	-0.3	$V_{DD} + 0.3$	V
Current into or out of $V_{DD}$ and $V_{SS}$ pins	-30	+30	mA
Current into or out of any other pin	-20	+20	mA

<b>D4 Package</b>	Min.	Max.	Units
Total Allowable Power Dissipation at $T_{amb} = 25^{\circ}\text{C}$		800	mW
... Derating		13	mW/ $^{\circ}\text{C}$
Storage Temperature	-55	+125	$^{\circ}\text{C}$
Operating Temperature	-40	+85	$^{\circ}\text{C}$

<b>P3 Package</b>	Min.	Max.	Units
Total Allowable Power Dissipation at $T_{amb} = 25^{\circ}\text{C}$		800	mW
... Derating		13	mW/ $^{\circ}\text{C}$
Storage Temperature	-55	+125	$^{\circ}\text{C}$
Operating Temperature	-40	+85	$^{\circ}\text{C}$

#### Operating Limits

Correct operation of the device outside these limits is not implied.

	Notes	Min.	Max.	Units
Supply ( $V_{DD} - V_{SS}$ )		3.0	5.5	V
Operating Temperature		-40	+85	$^{\circ}\text{C}$
Xtal Frequency	1	3.575965	3.583125	MHz

**Notes:** 1. A Xtal/Clock frequency of 3.5795MHz  $\pm$ 0.1% is required for correct FSK operation.

**Operating Characteristics**

For the following conditions unless otherwise specified:

$V_{DD} = 3.0V$  at  $T_{amb} = 25^{\circ}C$  and  $V_{DD} = 3.3V$  to  $5.5V$  at  $T_{amb} = -40$  to  $+85^{\circ}C$ ,

Xtal Frequency =  $3.579545MHz \pm 0.1\%$

0dBV corresponds to  $1.0V_{rms}$

0dBm corresponds to  $775mV_{rms}$  into  $600\Omega$ .

	Notes	Min.	Typ.	Max.	Units
<b>DC Parameters</b>					
$I_{DD}$ (M0 = '1', M1 = '1')	1, 2	-	1.0	-	$\mu A$
$I_{DD}$ (M0 or M1 = '0') at $V_{DD} = 3.0V$	1	-	1.0	1.25	mA
$I_{DD}$ (M0 or M1 = '0') at $V_{DD} = 5.0V$	1	-	1.7	2.5	mA
Logic '1' Input Level		70%	-	-	$V_{DD}$
Logic '0' Input Level		-	-	30%	$V_{DD}$
Logic Input Leakage Current ( $V_{in} = 0$ to $V_{DD}$ ), Excluding XTAL/CLOCK Input		-1.0	-	+1.0	$\mu A$
Output Logic '1' Level ( $I_{OH} = 360\mu A$ )		$V_{DD}-0.4$	-	-	V
Output Logic '0' Level ( $I_{OL} = 360\mu A$ )		-	-	0.4	V
RDYN O/P 'off' State Current ( $V_{out} = V_{DD}$ )		-	-	1.0	$\mu A$
<b>FSK Demodulator</b>					
Bit Rate		0	1200	1212	Baud
Mark (Logical '1') Frequency		1188	1200	1212	Hz
Space (Logical '0') Frequency		2178	2200	2222	Hz
Valid Input Level Range	3	-40.0	-	-8.0	dBV
Maximum Twist (Mark Level wrt Space Level)		$\pm 6.0$	-	-	dB
Acceptable Signal to Noise Ratio	4	20.0	-	-	dB
Level Detector 'On' Threshold Level	3	-	-	-40.0	dBV
Level Detector 'Off' to 'On' Time (Figure 4 Teon)		-	-	25.0	ms
Level Detector 'On' to 'Off' Time (Figure 4 Teoff)		8.0	-	-	ms
<b>FSK Retiming</b>					
Acceptable Rx Data Rate		1188	1200	1212	Baud
Tx Data Rate		1194	-	1206	Baud
<b>FSK Modulator</b>					
TXOP Level	5	-1.0	0	+1.0	dB
Twist (Mark Level wrt Space Level)		-2.0	0	+2.0	dB
<b>Tx 1200bits/sec (M1 = '0', M0 = '1').</b>					
Bit Rate		0	1200	1212	Baud
Mark (Logical '1') Frequency		1197	-	1203	Hz
Space (Logical '0') Frequency		2196	-	2204	Hz
<b>Tx 150bits/sec (M1 = '0', M0 = '0')</b>					
Bit Rate		0	150	152	Baud
Mark (Logical '1') Frequency		385	-	389	Hz
Mark (Logical '0') Frequency		485	-	489	Hz

	Notes	Min.	Typ.	Max.	Units
<b>Tx 5bits/sec (M1 = '1', M0 = '0').</b>					
Bit Rate		0	5.0	5.1	Baud
Mark (Logical '1') Frequency		385	-	389	Hz
Space (Logical '0') Frequency	6	-	0	-	Hz
<b>Data and Mode Timing</b>					
Rx Data Delay (RXIN to RXD)	9	-	2.55	-	ms
Tx Data Delay (TXD to TXOP)	9	-	0.1	-	ms
Mode ZP to Tx or Rx	10	-	-	20	ms
Mode Tx1200 to Rx1200	10	-	-	4.0	ms
Mode Rx1200 to Tx1200	10	-	-	0.2	ms
<b>Input Amplifier</b>					
Impedance (RXIN Pin)	7	10.0	-	-	MΩ
Voltage Gain	7	-	500	-	V/V
<b>XTAL/CLOCK Input</b>					
'High' Pulse Width	8	100	-	-	ns
'Low' Pulse Width	8	100	-	-	ns

- Notes:**
1. At 25°C, not including any current drawn from the FX614 pins by external circuitry other than X1, C1 and C2.
  2. TXD, RXEQ and CLK inputs at  $V_{SS}$ , M0 and M1 inputs at  $V_{DD}$ .
  3. Measured at the Rx Input Amplifier output (pin RXFB) for 1200Hz and  $V_{DD}= 5.0V$ .  
The internal threshold levels are proportional to  $V_{DD}$ . To cater for other supply voltages or different signal level ranges the voltage gain of the Rx Input Amplifier should be adjusted by selecting the appropriate external components as described in section 1.6.1
  4. Flat noise in 200 - 3200Hz band.
  5. Relative to 775mVrms at  $V_{DD}= 5.0V$  for load resistances greater than 40kΩ.
  6. TXOP held at approximately  $V_{DD}/2$ .
  7. Open loop, small signal low frequency measurements.
  8. Timing for an external input to the XTAL/CLOCK pin.
  9. Assuming data retiming is not enabled.
  10. Delay from mode change to reliable data at TXOP or RXD pins.

1.7.2 Packaging

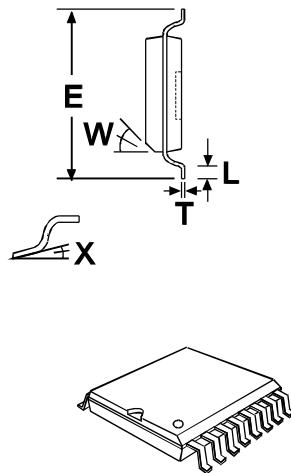
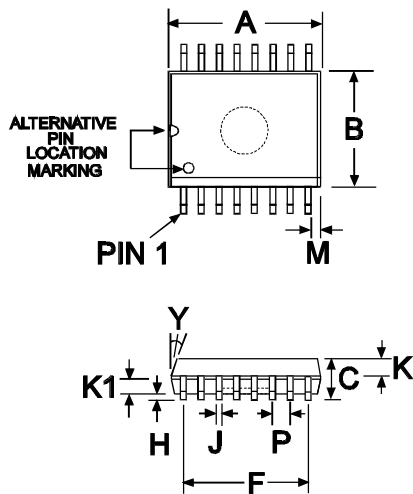

DIM.	MIN.	TYP.	MAX.
A	0.395 (10.03)		0.413 (10.49)
B	0.291 (7.39)		0.299 (7.59)
C	0.093 (2.36)		0.105 (2.67)
E	0.394 (10.01)		0.419 (10.64)
F		0.366 (9.29)	
H	0.004 (0.10)		0.012 (0.30)
J	0.013 (0.33)		0.019 (0.48)
K		0.041 (1.04)	
K1		0.041 (1.04)	
L	0.016 (0.41)		0.050 (1.27)
M	0.021 (0.53)		0.031 (0.79)
P		0.050 (1.27)	
T	0.009 (0.23)		0.012 (0.30)
W		45°	
X		0°	8°
Y		7°	

NOTE: All dimensions in inches (mm.)  
Angles in degrees

Figure 8 16-pin SOIC (D4) Mechanical Outline: Order as part no. FX614D4

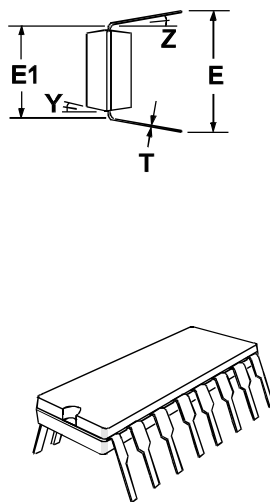
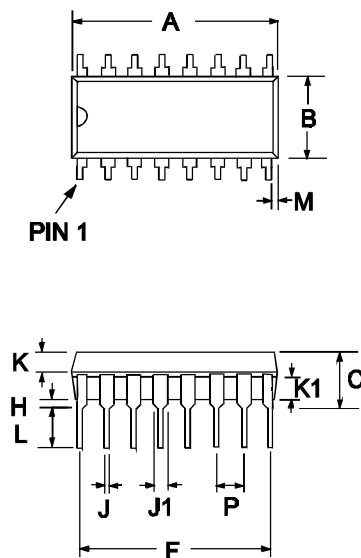

DIM.	MIN.	TYP.	MAX.
A	0.740 (18.80)		0.810 (20.57)
B	0.240 (6.10)		0.260 (6.60)
C	0.135 (3.43)		0.175 (4.45)
E	0.300 (7.62)		0.390 (9.91)
E1	0.290 (7.37)		0.325 (8.26)
F		0.70 (17.78)	
H	0.015 (0.38)		0.035 (0.89)
J	0.015 (0.38)		0.023 (0.58)
J1	0.040 (1.02)		0.065 (1.65)
K	0.056 (1.42)		0.064 (1.63)
K1	0.056 (1.42)		0.064 (1.63)
L	0.121 (3.07)		0.150 (3.81)
M		0.028 (0.72)	
P		0.100 (2.54)	
T	0.008 (0.20)		0.015 (0.38)
Y		7°	
Z		5°	

NOTE: All dimensions in inches (mm.)  
Angles in degrees

Figure 9 16-pin DIL (P3) Mechanical Outline: Order as part no. FX614P3

Handling precautions: This product includes input protection, however, precautions should be taken to prevent device damage from electro-static discharge. CML does not assume any responsibility for the use of any circuitry described. No IPR or circuit patent licences are implied. CML reserves the right at any time without notice to change the said circuitry and this product specification. CML has a policy of testing every product shipped using calibrated test equipment to ensure compliance with this product specification. Specific testing of all circuit parameters is not necessarily performed.



**CONSUMER MICROCIRCUITS LIMITED**

1 WHEATON ROAD  
WITHAM - ESSEX  
CM8 3TD - ENGLAND

Telephone: +44 1376 513833  
Telefax: +44 1376 518247  
e-mail: sales@cmlmicro.co.uk  
http://www.cmlmicro.co.uk





**CML Microcircuits**

COMMUNICATION SEMICONDUCTORS

## CML Product Data

In the process of creating a more global image, the three standard product semiconductor companies of CML Microsystems Plc (*Consumer Microcircuits Limited (UK)*, *MX-COM, Inc (USA)* and *CML Microcircuits (Singapore) Pte Ltd*) have undergone name changes and, whilst maintaining their separate new names (*CML Microcircuits (UK) Ltd*, *CML Microcircuits (USA) Inc* and *CML Microcircuits (Singapore) Pte Ltd*), now operate under the single title **CML Microcircuits**.

These companies are all 100% owned operating companies of the CML Microsystems Plc Group and these changes are purely changes of name and do not change any underlying legal entities and hence will have no effect on any agreements or contacts currently in force.

### CML Microcircuits Product Prefix Codes

Until the latter part of 1996, the differentiator between products manufactured and sold from MXCOM, Inc. and Consumer Microcircuits Limited were denoted by the prefixes MX and FX respectively. These products use the same silicon etc. and today still carry the same prefixes. In the latter part of 1996, both companies adopted the common prefix: CMX.

This notification is relevant product information to which it is attached.

Company contact information is as below:



**CML Microcircuits  
(UK) Ltd**

COMMUNICATION SEMICONDUCTORS

Oval Park, Langford, Maldon,  
Essex, CM9 6WG, England  
Tel: +44 (0)1621 875500  
Fax: +44 (0)1621 875600  
uk.sales@cmlmicro.com  
www.cmlmicro.com



**CML Microcircuits  
(USA) Inc.**

COMMUNICATION SEMICONDUCTORS

4800 Bethania Station Road,  
Winston-Salem, NC 27105, USA  
Tel: +1 336 744 5050,  
0800 638 5577  
Fax: +1 336 744 5054  
us.sales@cmlmicro.com  
www.cmlmicro.com



**CML Microcircuits  
(Singapore) Pte Ltd**

COMMUNICATION SEMICONDUCTORS

No 2 Kallang Pudding Road, 09-05/  
06 Mactech Industrial Building,  
Singapore 349307  
Tel: +65 7450426  
Fax: +65 7452917  
sg.sales@cmlmicro.com  
www.cmlmicro.com