

Description

The ZXSC410/420/440 are DC-DC boost controllers. Their wide input voltage range make suitable for operation from a number of battery configurations including single Li-Ion cell and 2-3 alkaline/NiCd/NiMH cells. Using high gain Diodes Zetex-brand switching npn-transistors allow high voltage boost ratios and/or high output current depending on transistor. The ZXSC410/440 has a shutdown feature that can also be used for some dimming functionality. ZXSC420/440 includes an End of Regulation flag that can be used to indicate when the regulator is no longer able to maintain the regulated output voltage/current or has reached the required current/voltage. The ZXSC440 combines the features of the ZXSC410 and ZXSC420 into one device.

Features

- 1.65V to 8V supply range
- Typical output regulation of $\pm 1\%$
- Over 85% typical efficiency
- Output currents up to 300mA
- 4.5 μ A typical shutdown current ZXSC410/440
- End of regulation output ZXSC420/440
- Available in SOT26 and MSOP-8
- **Totally Lead-Free & Fully RoHS compliant (Notes 1 & 2)**
- **Halogen and Antimony Free. "Green" Device (Note 3)**

Notes: 1. No purposely added lead. Fully EU Directive 2002/95/EC (RoHS) & 2011/65/EU (RoHS 2) compliant.
 2. See <http://www.diodes.com> for more information about Diodes Incorporated's definitions of Halogen- and Antimony-free, "Green" and Lead-free.
 3. Halogen- and Antimony-free "Green" products are defined as those which contain <900ppm bromine, <900ppm chlorine (<1500ppm total Br + Cl) and <1000ppm antimony compounds.

Pin Assignments

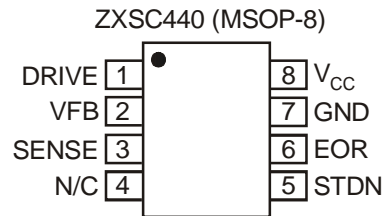
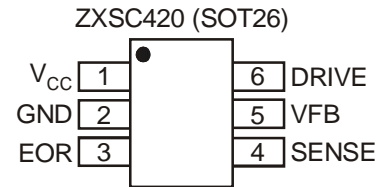
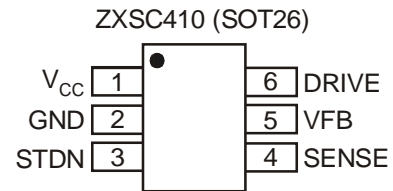

Applications

- System power for battery portable products
- LCD bias
- Local voltage conversion
- High Brightness LED driving

Typical Application Circuit

Pin Descriptions

Pin Name	Pin Number			Description
	ZXSC410	ZXSC420	ZXSC440	
V _{CC}	1	1	8	Supply Voltage
GND	2	2	7	Ground
STDN	3	-	5	Shutdown (ZXSC410 and ZXSC440)
EOR		3	6	End of regulation (ZXSC420 and ZXSC440)
Sense	4	4	3	Inductor current sense input. Internal threshold voltage set to 28mV. Connect external sense resistor.
V _{FB}	5	5	2	Reference voltage. Internal threshold set to 300mV. Connect external resistor network to set output voltage.
Drive	6	6	1	Drive output for external switching transistor. Connect to base or gate of external switching transistor.
NC			4	No connection

Functional Block Diagram

Absolute Maximum Ratings

Parameter	Rating	Unit
V _{CC}	-0.3 to +10	V
Drive	-0.3 to V _{CC} +0.3	V
EOR	-0.3 to V _{CC} +0.3	V
STDN	-0.3 to The lower of (+5.0) or (V _{CC} +0.3)	V
V _{FB} , Sense	-0.3 to The lower of (+5.0) or (V _{CC} +0.3)	V
Operating Temperature	-40 to +85	°C
Storage Temperature	-55 to +120	°C
Power Dissipation @ +25°C	450	mW

Caution: Stresses greater than the 'Absolute Maximum Ratings' specified above, may cause permanent damage to the device. These are stress ratings only; functional operation of the device at these or any other conditions exceeding those indicated in this specification is not implied. Device reliability may be affected by exposure to absolute maximum rating conditions for extended periods of time. Semiconductor devices are ESD sensitive and may be damaged by exposure to ESD events. Suitable ESD precautions should be taken when handling and transporting these devices.

Recommended Operating Conditions

Symbol	Parameter	Min	Max	Unit
V _{CC}	V _{CC} range	1.8	8	V
T _A	Ambient Temperature Range	-40	+85	°C
V _{IH}	Shutdown threshold	1.5	V _{CC}	V
V _{IL}	Shutdown threshold	0	0.55	V

Electrical Characteristics ($V_{CC} = 3V$, $T_A = -40^{\circ}C$ to $+85^{\circ}C$ unless otherwise specified.)

Symbol	Parameter	Conditions	Min	Typ	Max	Unit
I_Q (Note 4)	Quiescent current	$V_{CC} = 8V$			220	μA
I_{STDN}	Shutdown current			4.5		μA
E_{FF} (Note 5)	Efficiency	$50mA > I_{OUT} > 300mA$		85		%
ACC_{REF}	Reference tolerance	$1.8V < V_{CC} < 8V$	-3.0		+3.0	%
TCO_{REF}	Reference temp co.			0.005		%/ $^{\circ}C$
T_{DRV}	Discharge pulse width	$1.8V < V_{CC} < 8V$		1.7		μs
F_{OSC}	Operating frequency				200	kHz
Input Parameters						
V_{SENSE}	Sense voltage		22	28	34	mV
I_{SENSE}	Sense input current	$V_{FB} = 0V$; $V_{SENSE} = 0V$	-1	-7	-15	μA
V_{FB}	Feedback voltage	$T_A = +25^{\circ}C$	291	300	309	mV
I_{FB} (Note 5)	Feedback input current	$V_{FB} = 0V$; $V_{SENSE} = 0V$	-1.2		-4.5	μA
dV_{LN}	Line voltage regulation			0.5		%/V
Output Parameters						
I_{OUT} (Note 6)	Output current	$V_{IN} > 2V$, $V_{OUT} = V_{IN}$	300			mA
I_{DRIVE}	Transistor drive current	$V_{DRIVE} = 0.7V$	2	3.4	5	mA
V_{DRIVE}	Transistor voltage drive	$1.8V < V_{CC} < 8V$	0		$V_{CC} - 0.4$	V
C_{DRIVE}	MOSFET gate drive cap			300		pF
V_{OHEOR}	EOR flag output high	$I_{EOR} = -300nA$	2.5		V_{CC}	V
V_{OLEOR}	EOR flag output low	$I_{EOR} = 1mA$	0		1.15	V
T_{EOR}	EOR delay time	$T_A = +25^{\circ}C$	70	195	250	μs
dI_{LD}	Load current regulation				0.01	%/mA

- Notes:
4. Excluding gate/base drive current.
 5. I_{FB} is typically half of these values at 3V.
 6. System not device soec, including recommended transistors.

Typical Characteristics

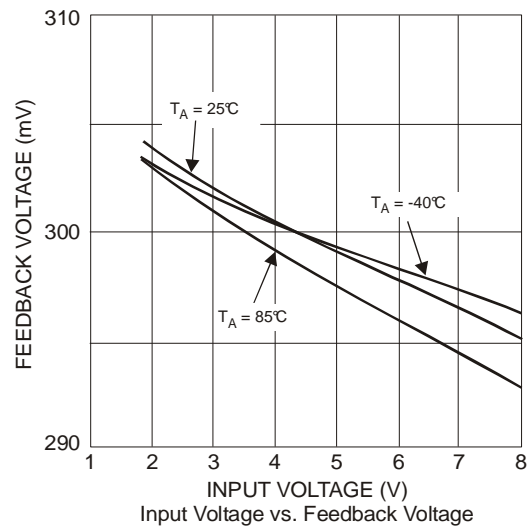
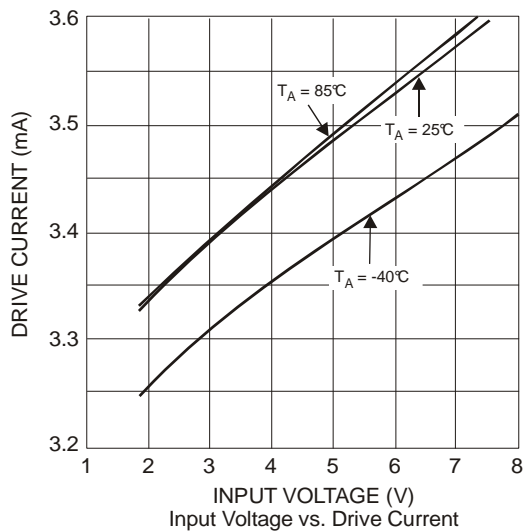
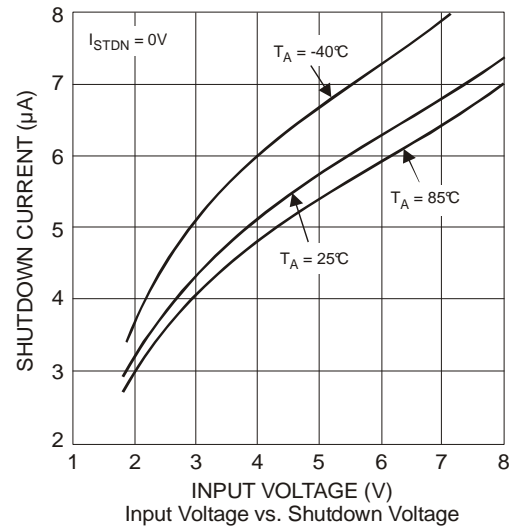
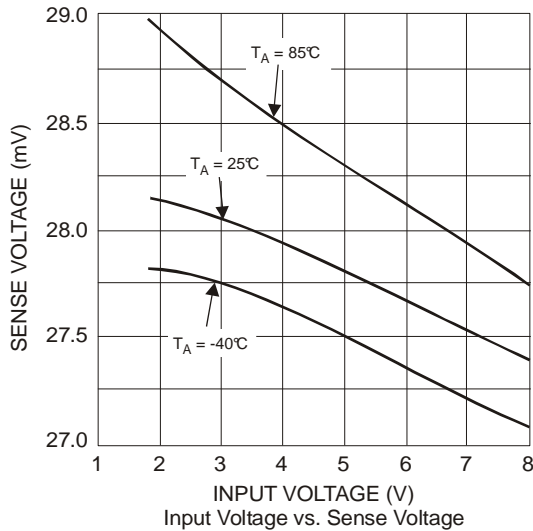

Application Information

Functional Blocks

Bandgap Reference

All threshold voltages and internal currents are derived from a temperature compensated bandgap reference circuit with a reference voltage of 1.22V nominal.

Dynamic Drive Output

Depending on the input signal, the output is either "LOW" or "HIGH". In the high state a 2.5mA current source (max drive voltage = $V_{CC} - 0.4V$) drives the base or gate of the external transistor. In order to operate the external switching transistor at optimum efficiency, both output states are initiated with a short transient current in order to quickly discharge the base or the gate of the switching transistor.

Switching Circuit

The switching circuit consists of two comparators, Comp1 and Comp2, a gate U1, a monostable and the drive output. Normally the DRIVE output is "HIGH"; the external switching transistor is turned on. Current ramps up in the inductor, the switching transistor and external current sensing resistor. This voltage is sensed by comparator, Comp2, at input I_{SENSE} . Once the current sense voltage across the sensing resistor exceeds 20mV, comparator Comp2 through gate U1 triggers a re-triggerable monostable and turns off the output drive stage for 2 μ s. The inductor discharges to the load of the application. After 2 μ s a new charge cycle begins, thus ramping the output voltage. When the output voltage reaches the nominal value and VFB gets an input voltage of more than 300mV, the monostable is forced "on" from Comp1 through gate U1, until the feedback voltage falls below 300mV. The above action continues to maintain regulation.

EOR, End of Regulation Detector (ZXSC420/440)

The EOR circuit is a retriggerable 120 μ s monostable, which is re-triggered by every down regulating action of comparator Comp1. As long as regulation takes place, output EOR is "HIGH" (high impedance, 100K to V_{CC}). Short dips of the output voltage of less than 120 μ s are ignored. If the output voltage falls below the nominal value for more than 120 μ s, output EOR goes "LOW". The reason for this to happen is usually a slowly progressing drop of input voltage from the discharging battery. Therefore the output voltage will also start to drop slowly. With the EOR detector, batteries can be used to the ultimate end of discharge, with enough time left for a safe shutdown. It can also be used in high-voltage photoflash with the ZXSC440 to show when the capacitor is fully charged.

Shutdown Control

The ZXSC410/440 offers a shutdown mode that consumes a standby current of less than 5 μ A. The ZXSC410/440 is enabled, and is in normal operation, when the voltage at the STDN pin is between 1V and 8V (and also open circuit). The ZXSC410/440 is shutdown with the driver disabled when the voltage at the STDN pin is 0.7V or lower. The STDN input is a high impedance current source of 1 μ A typ. The driving device can be an open-collector or -drain or a logic output with a "High" voltage of 5V max. The device shutdown current depends on the supply voltage, see typical characteristics graph. The ZXSC440 with its STDN pin and EOR pins can be used as a camera flash driver.

The STDN pin is used to initiate the high voltage capacitor charge cycle. The EOR pin is used as flag to show when the capacitor has been charged to the appropriate level.

A transformer is used to boost the voltage. If designing a transformer, bear in mind that the primary current may be over an amp and, if this flows through 10 turns, the primary flux will be 10 Amp. Small number of turns and small cores will need an air gap to cope with this value without saturation. Secondary winding capacitance should not be too high as this is working at 300V and could soon cause excessive losses.

External Component Selection

Switching Transistor Selection

The choice of switching transistor has a major impact on the converter efficiency. For optimum performance, a bipolar transistor with low $V_{CE(SAT)}$ and high gain is required. The V_{CEO} of the switching transistor is also an important parameter as this sees the full output voltage when the transistor is switched off. Diodes SOT26 transistors are an ideal choice for this application.

Schottky Diode Selection

As with the switching transistor, the Schottky rectifier diode has a major impact on the converter efficiency. A Schottky diode with a low forward voltage and fast recovery time should be used for this application.

The diode should be selected so that the maximum forward current rating is greater or equal to the maximum peak current in the inductor, and the maximum reverse voltage is greater or equal to the output voltage. The Diodes ZHCS Series meet these needs.

Inductor Selection

The inductor value must be chosen to satisfy performance, cost and size requirements of the overall solution.

Inductor selection has a significant impact on the converter performance. For applications where efficiency is critical, an inductor with a series resistance of 500m Ω or less should be used.

Application Information (cont.)

Output Capacitors

Output capacitors are a critical choice in the overall performance of the solution. They are required to filter the output and supply load transient currents. There are three parameters which are paramount in the selection of the output capacitors, capacitance, I_{RIPPLE} and ESR. The capacitance value is selected to meet the load transient requirements. The capacitors I_{RIPPLE} rating must meet or exceed the current ripple of the solution.

The ESR of the output capacitor can also affect loop stability and transient performance. The capacitors selected for the solutions, and indicated in the reference designs, are optimised to provide the best overall performance.

Input Capacitors

The input capacitor is chosen for its voltage and RMS current rating. The use of low ESR electrolytic or tantalum capacitors is recommended. Capacitor values for optimum performance are suggested in the reference design section.

Also note that the ESR of the input capacitor is effectively in series with the input and hence contributes to efficiency losses in the order of I_{RMS}^2 ESR.

Peak Current Definition

In general, the I_{PK} value must be chosen to ensure that the switching transistor, Q1, is in full saturation with maximum output power conditions, assuming worse case input voltage and transistor gain under all operating temperature extremes. Once I_{PK} is decided the value of R_{SENSE} can be determined by:

$$R_{SENSE} = \frac{V_{SENSE}}{I_{PK}}$$

Sense Resistor

A low value sense resistor is required to set the peak current. Power in this resistor is negligible due to the low sense voltage threshold, V_{SENSE} .

Output Power Calculation

By making the above assumptions for inductance and peak current the output power can be determined by:

$$P_{OUT} = I_{AV} \times V_{IN} \times \eta = (\text{Watts})$$

where

$$I_{AV} = \frac{I_{PK}}{2} \times \frac{(T_{ON} + T_{DIS})}{(T_{ON} + T_{OFF})}$$

and

$$T_{ON} = \frac{I_{PK} \times L}{V_{IN}}$$

and

$$T_{DIS} = \frac{I_{PK} \times L}{V_{IN} - V_{OUT}}$$

and

$$T_{OFF} \approx 1.7\mu\text{s} \text{ (internally set by ZXSC410)}$$

and

$$\eta = \text{efficiency i.e. } 100\% = 1$$

Operating frequency can be derived by:

$$F = \frac{1}{T_{ON} + T_{OFF}}$$

Output Adjustment

The ZXSC410/420 are adjustable output controllers allowing the end user the maximum flexibility. They can be used both as switching voltage regulators and as constant current regulators. A feedback voltage of 300mV provides a good compromise for both voltage and current regulation.

For a constant output voltage operation a potential divider network is connected as follows:

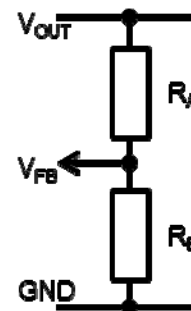

The output voltage is determined by the equation:

$$V_{OUT} = V_{FB} \left(1 + \frac{R_A}{R_B} \right)$$

where $V_{FB} = 300\text{mV}$

The resistor values, R_A and R_B , should be maximised to improve efficiency and decrease battery drain. Optimisation can be achieved by providing a minimum current of $I_{FB(MAX)} = 200\text{nA}$ to the VFB pin. Output is adjustable from V_{FB} to the $(BR)V_{CEO}$ of the switching transistor, Q1.

Note: For the reference designs, R_A is assigned the label R2 and R_B the label R3.

The ZXSC410/420/440 can also be used to generate a constant current between boosted output rail and the VFB pin by connecting a single resistor between VFB and GND.

Application Information (cont.)

LED Driving

The ZXSC410/420/440 make simple low voltage boost LED drivers.

The resistor value is determined by the following:

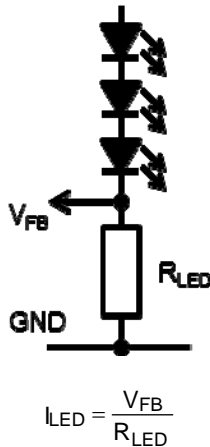

Open-Circuit Protection

As a boost converter if the load (LED chain) should become open-circuit a Zener diode can be connected across the LED chain preventing over-voltage and possible damage to the main switching transistor. The Zener diodes should be selected by ensuring its voltage rating is higher than the combined forward voltage of the LED chain. Under open circuit conditions the current in the Zener diode defines the output current as:

$$I_Z = \frac{V_{FB}}{R_Z}$$

The circuit example below give an open circuit output current of 300µA.

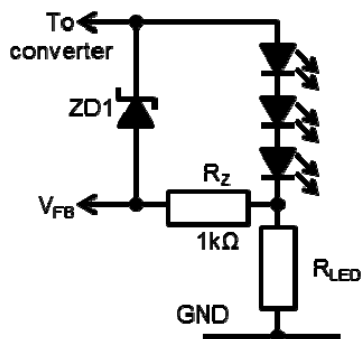

Dimming Control

There are four types of dimming control that can be implemented for the ZXSC410/440.

Dimming Control using the Shutdown Pin

The first method uses the shutdown pin. By injecting a PWM waveform on this pin and varying the duty cycle, LED current and hence LED brightness can be adjusted.

To implement this method of brightness control on the ZXSC410/440, a PWM signal with amplitude of between 0.7V and ZXSC410/ZXSC420/ZXSC440
Document number: DS33618 Rev. 3 - 2

V_{CC} at a frequency of 120Hz or above (to eliminate LED flicker) should be applied to the STDN pin. The LED current and hence LED brightness is linearly proportional to the duty cycle ratio, so for brightness control adjust duty cycle ratio as necessary. For example, a 10% duty cycle equates to 10% of full LED brightness.

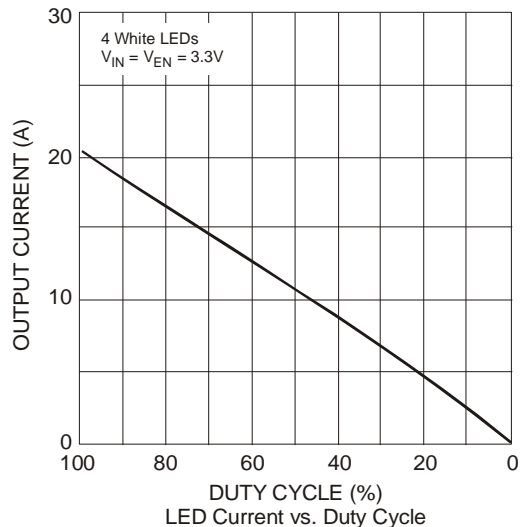

Dimming Control using a DC Voltage

For applications where a PWM signal is not available a DC voltage can be used to control dimming by modulating the V_{FB} pin.

By adding resistors R2 and R3 and applying a DC voltage, the LED current can be adjusted from 100% to 0%. As the DC voltage increases, the voltage drop across R2 increases and the voltage drop across R1 decreases, thus reducing the current through the LEDs.

Selection of R2 and R3 should ensure that the current from the DC voltage is much less than the LED current and much larger than the feedback current. The component values in the diagram above represent 0% to 100% dimming control from a 0 to 2V DC voltage.

Application Information (cont.)

Dimming Control Using a Filtered PWM Signal

The filtered PWM signal can be considered as an adjustable DC voltage by applying a RC filter. The values shown in the diagram below are configured to give 0% to 100% dimming for a 1kHz to 100kHz PWM signal with a 2V amplitude. e.g. a 50% duty cycle will give 50% dimming.

Dimming Control using a Logic Signal

For applications where the LED current needs to be adjusted in discrete steps a logic signal can be applied as shown in the diagram below.

When Q1 is 'off', R1 sets the minimum LED current. When Q1 is 'on', R2 sets the LED current that will be added to the minimum LED current. The formula for selecting values for R1 and R2 are given below:

MOSFET 'off'

$$I_{LED(MIN)} = \frac{V_{FB}}{R_1} I$$

MOSFET 'on'

$$I_{LED(MAX)} = \frac{V_{FB}}{R_2} + I_{LED(MIN)}$$

Layout Issues

Layout is critical for the circuit to function in the most efficient manner in terms of electrical efficiency, thermal considerations and noise.

For 'step-up converters' there are four main current loops, the input loop, power-switch loop, rectifier loop and output loop. The supply charging the input capacitor forms the input loop. The power-switch loop is defined when Q1 is 'on', current flows from the input through the inductor, Q1, R_{SENSE} and to ground. When Q1 is 'off', the energy stored in the inductor is transferred to the output capacitor and load via D1, forming the rectifier loop. The output loop is formed by the output capacitor supplying the load when Q1 is switched back off.

To optimise for best performance each of these loops kept separate from each other and interconnected with short, thick traces thus minimising parasitic inductance, capacitance and resistance. Also the R_{SENSE} resistor should be connected, with minimum trace length, between emitter lead of Q1 and ground, again minimizing stray parasitics.

Application Examples

ZXSC410 DC-DC Boost Voltage Regulators

$V_{IN} = 2.5V$ to $4.2V$, $V_{OUT} = 5V$; $I_{LOAD} = 100mA$

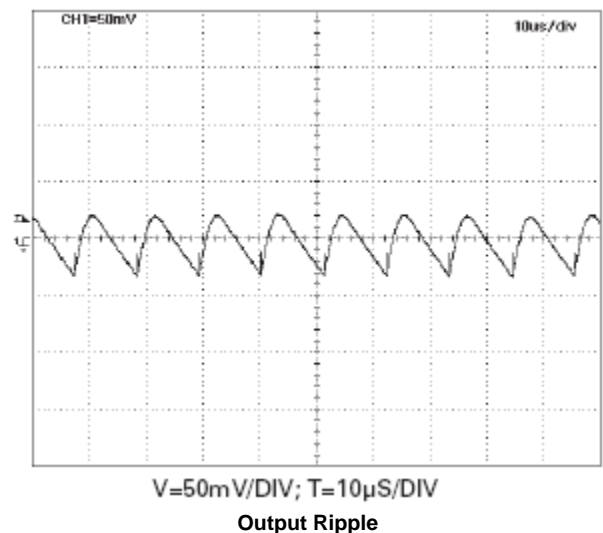
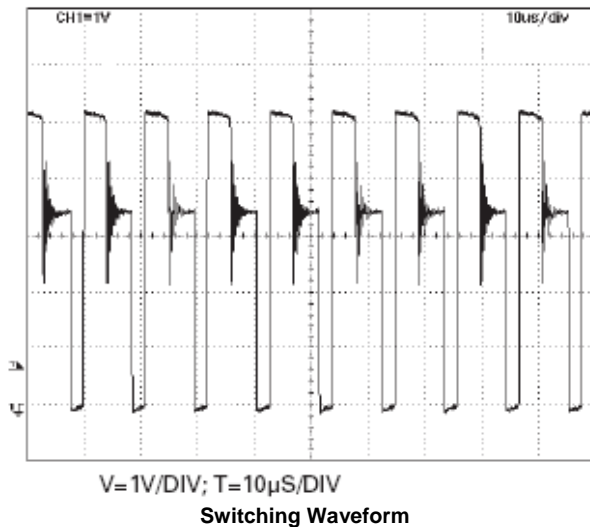
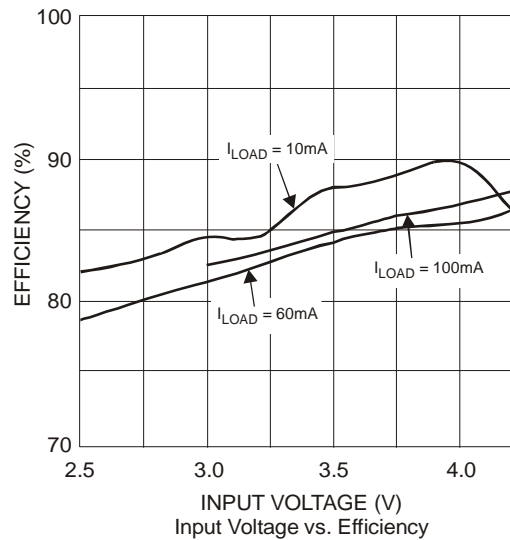
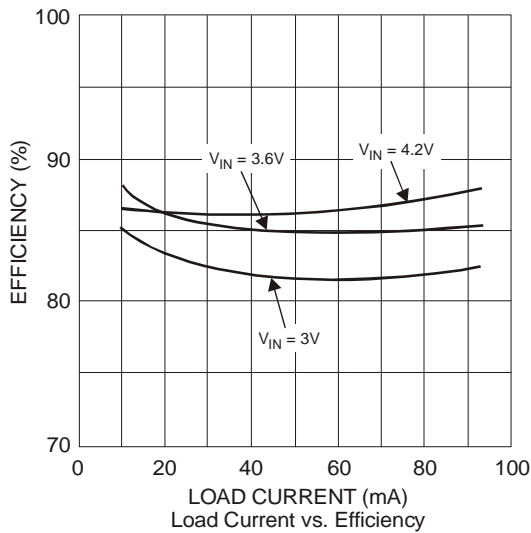

Application Examples (cont.)

Triple Output TFT Bias Generator

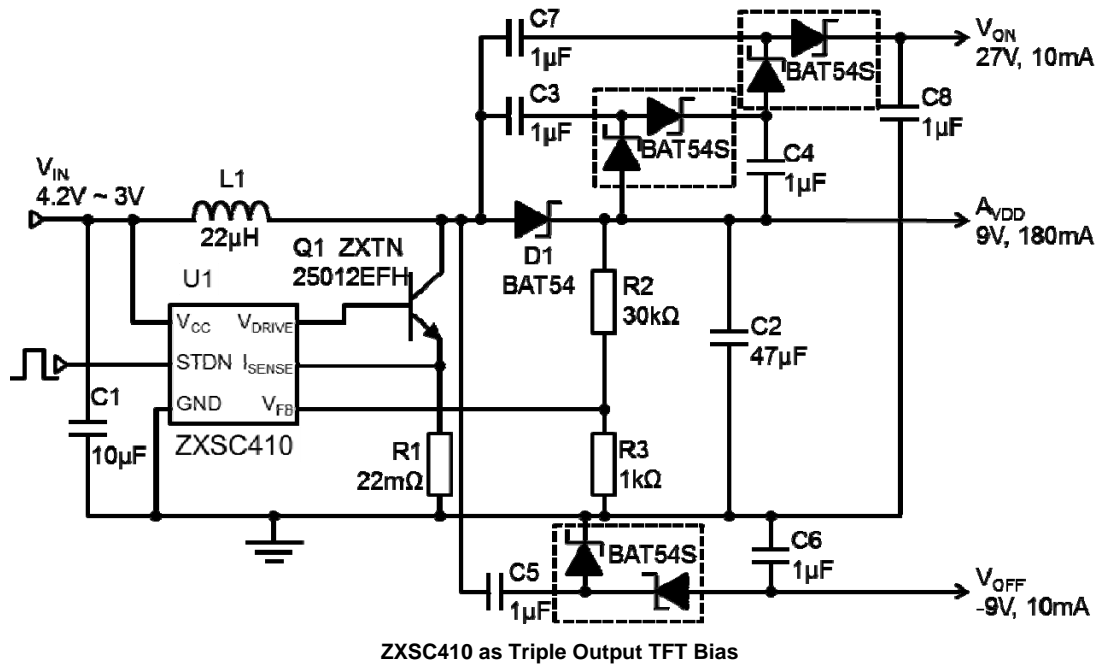

Sequencing A_{VDD} and V_{ON}

By adding the circuit below to the LCD bias output (V_{ON}) of the converter a 10ms delay can be achieved between A_{VDD} power up and V_{ON} power up. The circuit operates by a delay in turning the PMOS transistor on, which transfers to a 10ms delay between input and output of the circuit.

The delay is set by the RC time constant of R1 and C1. The diode, D1, discharges the gate of the PMOS when the main system supply is turned off, guaranteeing a delay every turn on cycle.

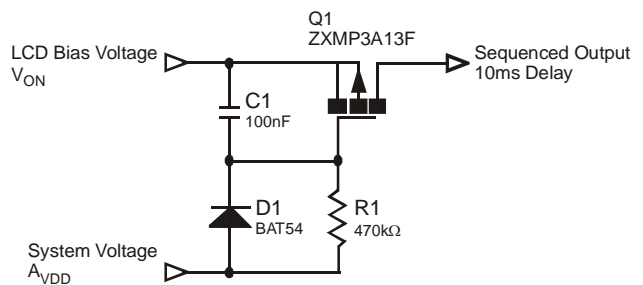

Application Examples (cont.)

Battery Powered Two 1W LED Lamp

This application shows the ZXSC410/420/440 driving 2 serial LEDs. The input voltage ranges from 2V to 3.6V with a maximum output current of 360mA from 2.6V input.

The wide input voltage range allows the use of different battery cell combinations. This could be dual alkaline cells with voltage starting from 3V down to 2V or triple NiCad/NiMH cells with voltage starting from 3.6V down to 2.7V.

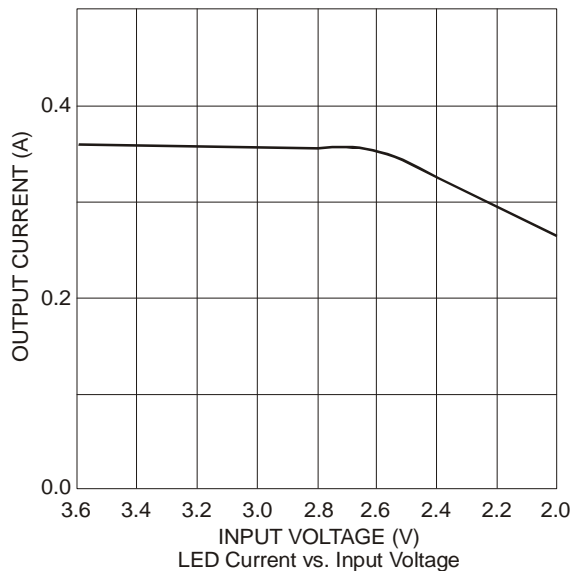
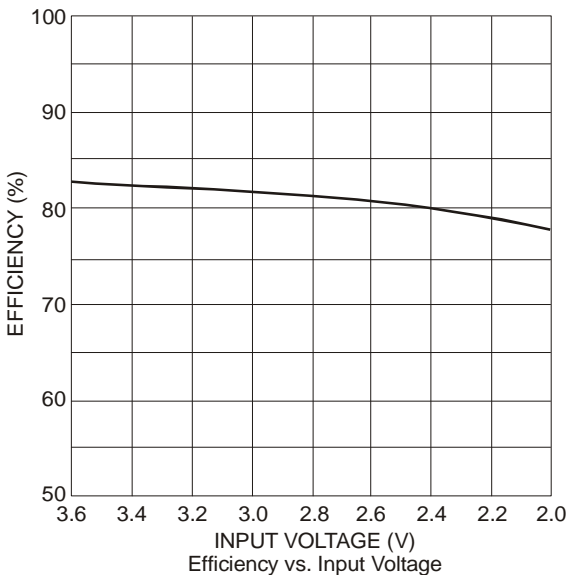

Application Circuits (cont.)

High Current LED Photoflash

The input voltage is 3V with a maximum pulsed output current of 1A for 2ms.

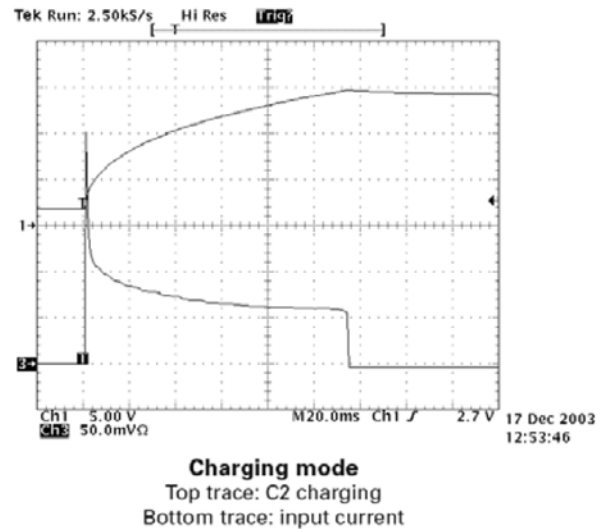
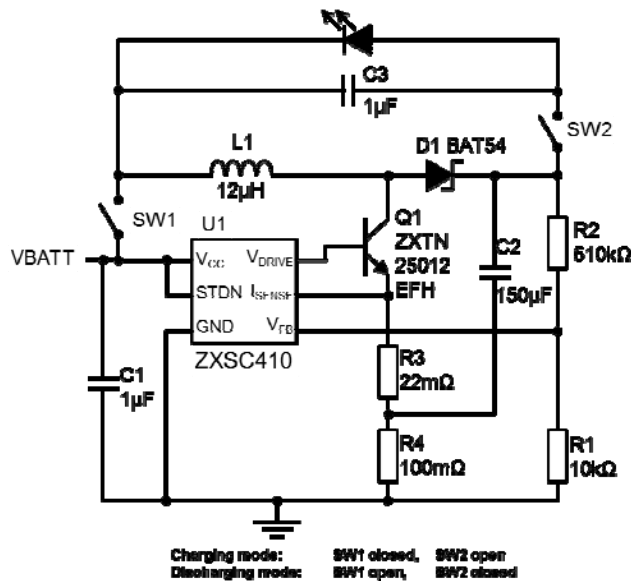

Operation

In charging mode, SW1 is closed and SW2 is open the ZXSC410/420/440 is configured as a typical boost converter, charging capacitor C2 up the regulated output voltage set by the ratio of R1 and R2. This is typically 16V. The peak current of the converter (current drawn from the battery) is controlled by R3 plus R4, and is typically 280mA for this application. When C2 is charged to 16V the SW1 is opened and SW2 is closed, converting the ZXSC400 to a step down converter to provide a 1A constant current for 2ms to the photoflash LED. During step down operation, current flows from C2, through the photoflash LED, L1, U2 and is returned to C2 through R3. This means that the peak current is set at a higher value than in charging mode, typically 1A. When the current reaches its peak value, U2 is switched off and current flows from L1 through the Schottky diode in U2, to the photoflash LED. This cyclic process is repeated until C2 is discharged.

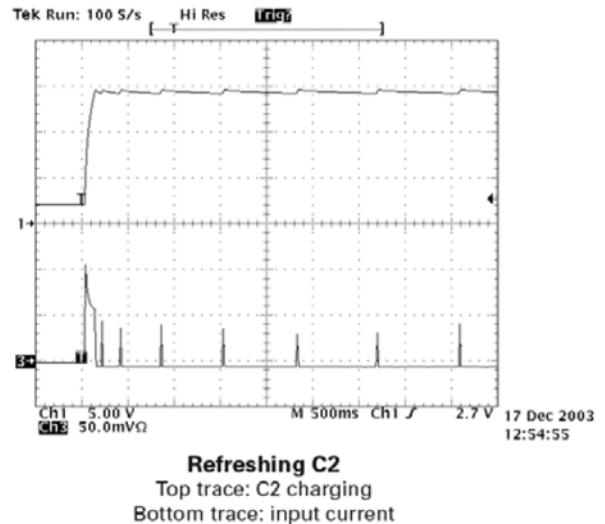

Ordering Information

Device	Part Mark	Package Code	Packaging	7" Tape & Reel	
				Quantity	Part Number Suffix
ZXSC410E6TA	C410	E6	SOT26	3000	TA
ZXSC420E6TA	C420	E6	SOT26	3000	TA
ZXSC440X8TA	ZXSC 440	X8	MSOP-8	1000	TA

Package Outline Dimensions (All Dimensions in mm)

SOT26

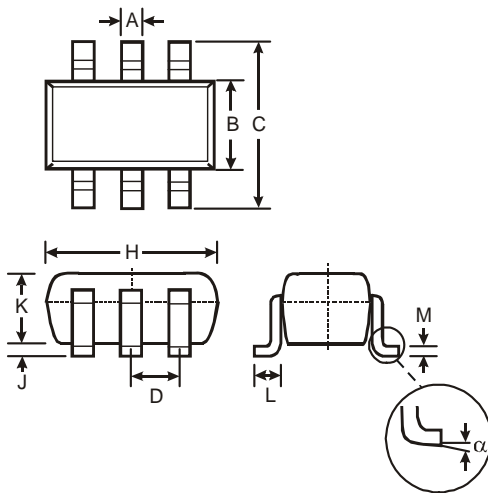

SOT26			
Dim	Min	Max	Typ
A	0.35	0.50	0.38
B	1.50	1.70	1.60
C	2.70	3.00	2.80
D	—	—	0.95
H	2.90	3.10	3.00
J	0.013	0.10	0.05
K	1.00	1.30	1.10
L	0.35	0.55	0.40
M	0.10	0.20	0.15
α	0°	8°	—
All Dimensions in mm			

MSOP-8

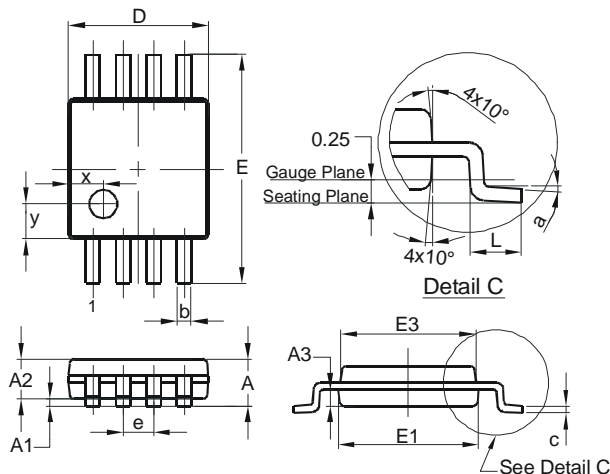

MSOP-8			
Dim	Min	Max	Typ
A	-	1.10	-
A1	0.05	0.15	0.10
A2	0.75	0.95	0.86
A3	0.29	0.49	0.39
b	0.22	0.38	0.30
c	0.08	0.23	0.15
D	2.90	3.10	3.00
E	4.70	5.10	4.90
E1	2.90	3.10	3.00
E3	2.85	3.05	2.95
e	-	-	0.65
L	0.40	0.80	0.60
a	0°	8°	4°
x	-	-	0.750
y	-	-	0.750
All Dimensions in mm			

Suggested Pad Layout

SOT26

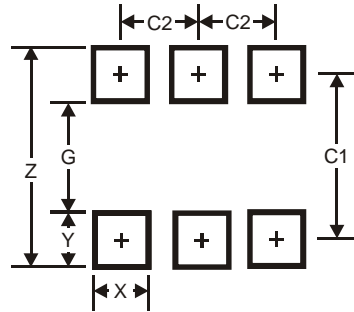

Dimensions	Value (in mm)
Z	3.20
G	1.60
X	0.55
Y	0.80
C1	2.40
C2	0.95

MSOP-8

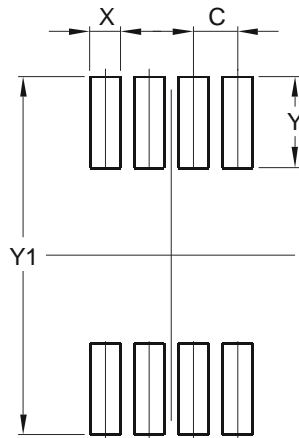

Dimensions	Value (in mm)
C	0.650
X	0.450
Y	1.350
Y1	5.300

IMPORTANT NOTICE

DIODES INCORPORATED MAKES NO WARRANTY OF ANY KIND, EXPRESS OR IMPLIED, WITH REGARDS TO THIS DOCUMENT, INCLUDING, BUT NOT LIMITED TO, THE IMPLIED WARRANTIES OF MERCHANTABILITY AND FITNESS FOR A PARTICULAR PURPOSE (AND THEIR EQUIVALENTS UNDER THE LAWS OF ANY JURISDICTION).

Diodes Incorporated and its subsidiaries reserve the right to make modifications, enhancements, improvements, corrections or other changes without further notice to this document and any product described herein. Diodes Incorporated does not assume any liability arising out of the application or use of this document or any product described herein; neither does Diodes Incorporated convey any license under its patent or trademark rights, nor the rights of others. Any Customer or user of this document or products described herein in such applications shall assume all risks of such use and will agree to hold Diodes Incorporated and all the companies whose products are represented on Diodes Incorporated website, harmless against all damages.

Diodes Incorporated does not warrant or accept any liability whatsoever in respect of any products purchased through unauthorized sales channel.

Should Customers purchase or use Diodes Incorporated products for any unintended or unauthorized application, Customers shall indemnify and hold Diodes Incorporated and its representatives harmless against all claims, damages, expenses, and attorney fees arising out of, directly or indirectly, any claim of personal injury or death associated with such unintended or unauthorized application.

Products described herein may be covered by one or more United States, international or foreign patents pending. Product names and markings noted herein may also be covered by one or more United States, international or foreign trademarks.

LIFE SUPPORT

Diodes Incorporated products are specifically not authorized for use as critical components in life support devices or systems without the express written approval of the Chief Executive Officer of Diodes Incorporated. As used herein:

- A. Life support devices or systems are devices or systems which:
1. are intended to implant into the body, or
 2. support or sustain life and whose failure to perform when properly used in accordance with instructions for use provided in the labeling can be reasonably expected to result in significant injury to the user.
- B. A critical component is any component in a life support device or system whose failure to perform can be reasonably expected to cause the failure of the life support device or to affect its safety or effectiveness.

Customers represent that they have all necessary expertise in the safety and regulatory ramifications of their life support devices or systems, and acknowledge and agree that they are solely responsible for all legal, regulatory and safety-related requirements concerning their products and any use of Diodes Incorporated products in such safety-critical, life support devices or systems, notwithstanding any devices- or systems-related information or support that may be provided by Diodes Incorporated. Further, Customers must fully indemnify Diodes Incorporated and its representatives against any damages arising out of the use of Diodes Incorporated products in such safety-critical, life support devices or systems.

Copyright © 2012, Diodes Incorporated

www.diodes.com