

# Features

## Unregulated Converter

- Fully RoHS 6/6 Conform
- Full Power at 100°C Ambient Temperature
- 1kVDC Isolation
- Suitable for Fully Automated Assembly (including Vapour Phase Soldering)
- Optional Continuous Short Circuit Protection

### Selection Guide

Part Number SMD	Input Voltage (VDC)	Output Voltage (VDC)	Output Current (mA)	Efficiency typ. (%)	Max Capacitive Load <sup>(1)</sup> **
R1DA**xx3.33.3	3.3, 5, 9, 12, 15, 24	3.3/3.3	150/150	75	470µF/470µF
R1DA**xx0505	3.3, 5, 9, 12, 15, 24	5/5	100/100	72-78	470µF/470µF
R1DA**xx0909	3.3, 5, 9, 12, 15, 24	9/9	56/56	74-78	220µF/220µF
R1DA**xx1212	3.3, 5, 9, 12, 15, 24	12/12	42/42	75-80	68µF/68µF
R1DA**xx1515	3.3, 5, 9, 12, 15, 24	15/15	33/33	75-82	68µF/68µF

xx = Input Voltage (other input and output voltage combinations available on request)

\* add Suffix "P" for Continuous Short Circuit Protection, e. g. R1DA-050505/P

\* add Suffix -R for Tape & Reel Packing e.g. R1DA-050505-R. For more Details see Application Notes.

### Specifications (measured at T<sub>A</sub> = 25°C, nominal input voltage, full load and after warm-up)

Input Voltage Range			±10%
Output Voltage Accuracy			-1% typ., ±5% max.
Line Voltage Regulation (Low Line to High Line @ max. Load)	All Variants	1% typ.	
Load Regulation (10% to 100% Load)	3.3V output types	15% typ., 20% max.	
	5V output types	12% typ. / 15% max.	
	9V output types	7% typ., 10% max.	
	2V, 15V output types	6% typ., 10% max.	
Output Ripple and Noise (20MHz BW limited)			50 mVp-p typ. / 100mVp-p max.
Operating Frequency			20kHz min. / 50kHz typ. / 90kHz max.
Efficiency at Full Load			See Selection Guide
Minimum Load = 0%	Specifications valid for 10% minimum Load only		
Isolation Voltage Input/Output	(tested for 1 second)	1000VDC	
Isolation Voltage Output/Output	(rated for 1 minute)	500VAC / 60Hz	
Isolation Capacitance			75pF max.
Isolation Resistance	V <sub>ISO</sub> =500V	10 GΩ min.	
Short Circuit Protection			1 Second
P-Suffix			Continuous
Operating Temperature Range			-40°C to +100°C (see Graph)
Storage Temperature Range			-50°C to +125°C
Reflow Temperature	RoHS compliant	245°C (30 sec), Peak 255°C (5 sec) max.	
Vapour Phase Process	(for more details see Application Notes)		230°C (90 sec) max.
Relative Humidity			95% RH
Humidity Susceptibility Test			1000 hrs / 90% humidity / +85°C ambient
Package Weight			1.2g
Packing Quantity			33 pcs per tube / 500 pcs per reel
MTBF	Using MIL-HDBK 217F (+25°C)	1045 x 10 <sup>3</sup> hours	
	Using MIL-HDBK 217F (+85°C)	183 x 10 <sup>3</sup> hours	

Detailed Information see Application Notes chapter „MTBF“

# ECONOLINE

## DC/DC-Converter



# 1 Watt SMD Dual Independent Outputs



**EN-60950-1-Certified**  
**UL-60950-1-Certified**

# R1DA

### Description

The R1DA converters are of the enclosed open frame type, i.e. they are not potted.

The converters are typically used in general purpose and industrial low power isolation and voltage matching applications where an SMD converter is required.

The converter series feature an extended ambient temperature operating range of -40°C - +100°C without derating and optional continuous short circuit protection.

In addition to single, dual and independent outputs, two isolation options and three different case formats, the converters are also available pre-packed as tape and reel for use with automatic insertion machines.

Refer to Application Notes

## Specifications - continued

### Certifications

EN General Safety	Report: 10010807-2009	EN-60950-1, 2nd Edition
Conducted Emissions		EN55022 Class B with Filter
Radiated Emissions		EN55022 Class B with Filter
UL General Safety	Report: E224736-A9-UL	UL60950-1, 2nd Edition

### Notes

Note 1: Maximum capacitive load is defined as the capacitive load that will allow start up in under 1 second without damage to the converter.

## Derating-Graph (Ambient Temperature)

### R1DA-0505

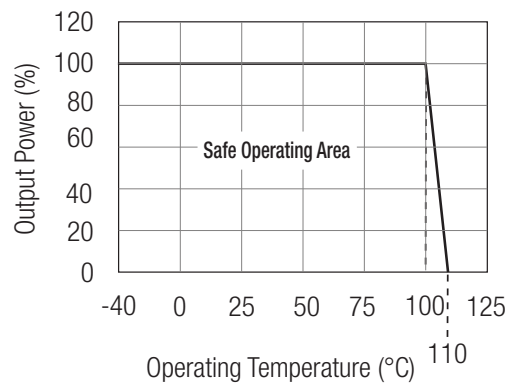

## Tolerance Envelope

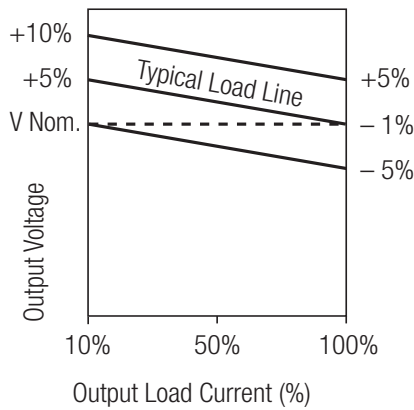

## Typical Characteristics

### R1DA-xx0505

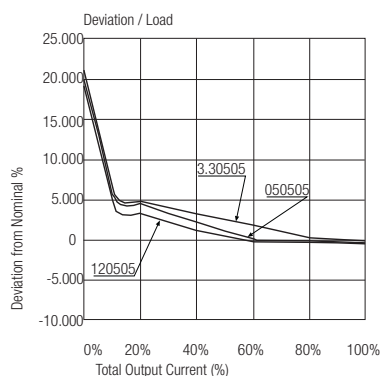
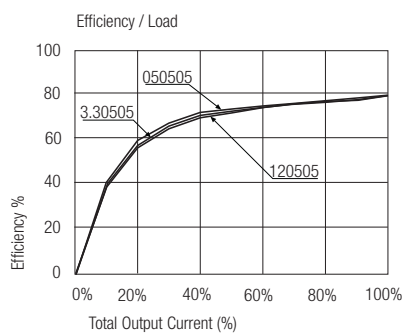

### R1DA-xx1212

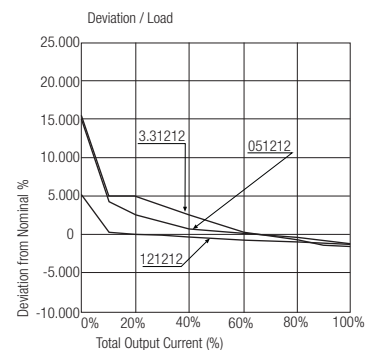
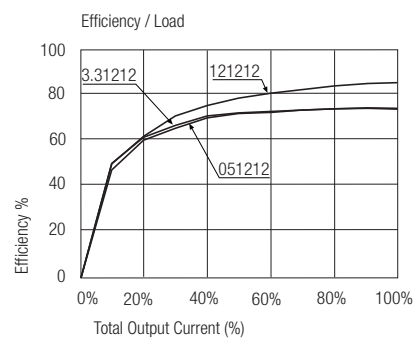

### Package Style and Pinning (mm)

#### 2 PIN Dual SMD Package

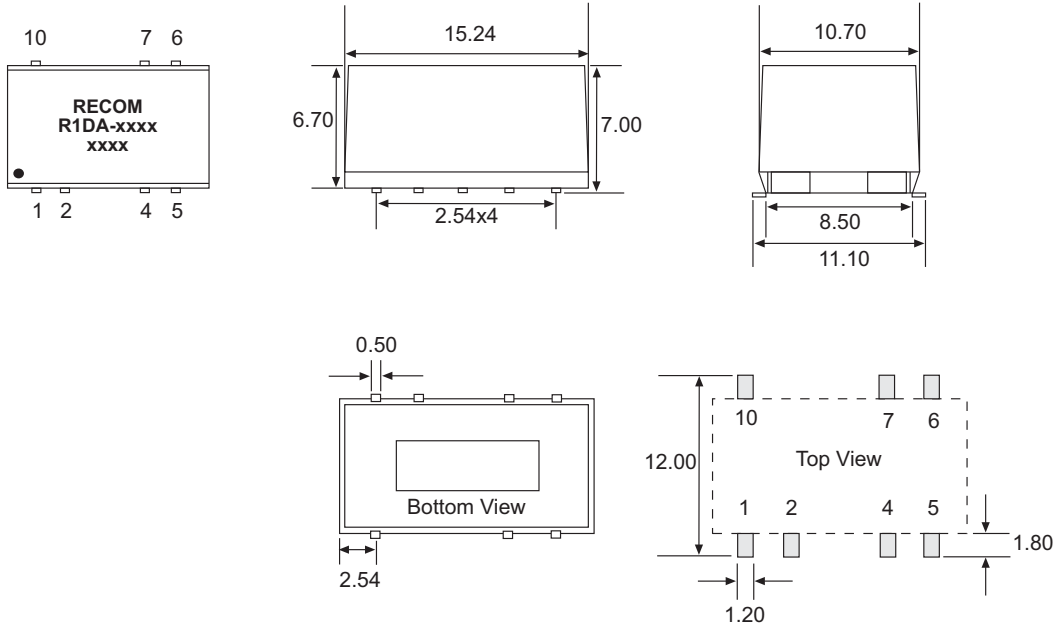

#### Pin Connections

Pin #	Function
1	-Vin
2	+Vin
4	-Vout1
5	+Vout1
6	-Vout2
7	+Vout2
10	NC

NC= No Connection

### EMC Filtering - Suggestion for EN55022 Class B (Conducted and Emited)

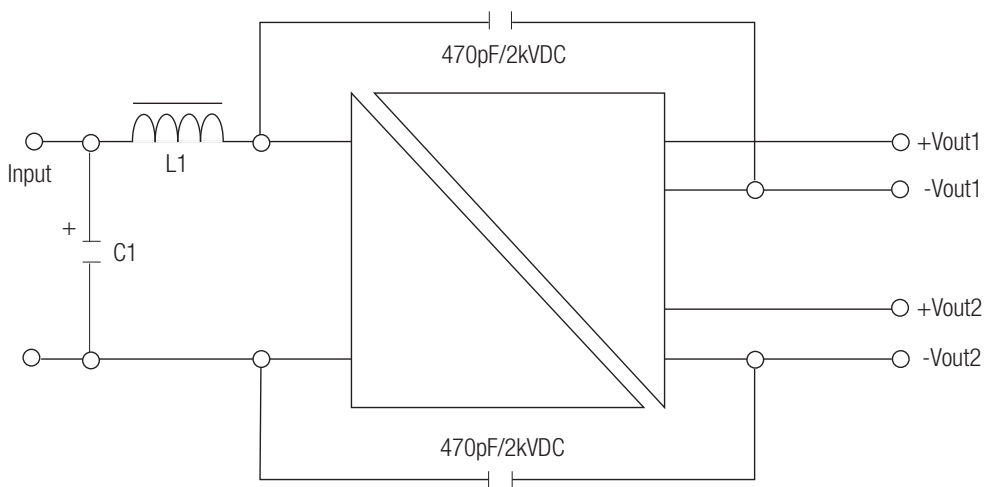

#### Standard

C1	L1	Vin
2.2µF	4.7µH	3.3V
2.2µF	4.7µH	5V
2.2µF	10µH	9V
2.2µF	10µH	12V
2.2µF	10µH	15V
2.2µF	22µH	24V

#### /P versions

C1	L1	Vin
4.7µF	10µH	3.3V
4.7µF	10µH	5V
4.7µF	10µH	9V
4.7µF	10µH	12V
4.7µF	22µH	15V

C1 = MLCC  
L1 = SMD Inductor