

## Features

- Non-Isolated
- Synchronous rectification design
- Adjustable Output voltage
- 2, 3, 4AMP Adjustable Positive Step Down Integrated Switching Regulator
- Over load protection (125% full load typical)
- Remote ON/OFF Control(Ground Off)
- Wide Input Range
- UL94V-0 Package Material
- Continuous short circuit protection (Very low short current  $I_{sc} < 50mA$ )
- Input voltage range 4.5V~28V
- Efficiency to 97%

## Description

The R-7XXX series is a high performance 2.5V to 15V , 2Amp to 4Amp, 12-Pin SIP (single in-line package), Integrated switching regulator (ISR). The Synchronous - rectified design yields excellent efficiencies up to 97%. Short circuit protection with crowbar function reduces the short circuit current to under 50mA of input current.

## Selection Guide

| Part Number<br>SIP12 | Input Range<br>(V) | Nominal Output Voltage<br>(V) | Vout Adjust Range<br>(V) | Output Current<br>(A) | Efficiency (%) |     |          |
|----------------------|--------------------|-------------------------------|--------------------------|-----------------------|----------------|-----|----------|
|                      |                    |                               |                          |                       | Min. Vin       | 12V | Max. Vin |
| R-723.3x             | 4.5 – 28           | 3.3                           | 2.5 – 5.5                | 2                     | 95             | 93  | 89       |
| R-725.0x             | 6.5 – 28           | 5.0                           | 3.0 – 5.5                | 2                     | 96             | 95  | 91       |
| R-726.5x             | 8.5 – 28           | 6.5                           | 5.0 – 8.0                | 2                     | 97             | 96  | 93       |
| R-729.0x             | 12 – 28            | 9.0                           | 7.0 – 11                 | 2                     | 96             | -   | 93       |
| R-7212x              | 15 – 28            | 12                            | 10 – 14                  | 2                     | 97             | -   | 95       |
| R-7215x              | 19 – 28            | 15                            | 13 – 17                  | 2                     | 97             | -   | 96       |
| R-733.3x             | 4.5 – 28           | 3.3                           | 2.5 – 5.5                | 3                     | 94             | 93  | 89       |
| R-735.0x             | 6.5 – 28           | 5.0                           | 3.0 – 5.5                | 3                     | 95             | 95  | 92       |
| R-736.5x             | 8.5 – 28           | 6.5                           | 5.0 – 8.0                | 3                     | 97             | 96  | 93       |
| R-739.0x             | 12 – 28            | 9.0                           | 7.0 – 11                 | 3                     | 96             | -   | 94       |
| R-7312x              | 15 – 28            | 12                            | 10 – 14                  | 3                     | 97             | -   | 96       |
| R-7315x              | 19 – 28            | 15                            | 13 – 17                  | 3                     | 97             | -   | 96       |
| R-743.3x             | 4.5 – 28           | 3.3                           | 2.5 – 5.5                | 4                     | 93             | 92  | 88       |
| R-745.0x             | 6.5 – 28           | 5.0                           | 3.0 – 5.5                | 4                     | 95             | 94  | 91       |
| R-746.5x             | 8.5 – 28           | 6.5                           | 5.0 – 7.5                | 4                     | 96             | 96  | 93       |

Note:  $V_{in} - V_{out} \geq 1.5V - 4.0V$  depending on  $V_{out}$  if adjust function is used!

Suffix x: (see mechanical drawing for details)

x = P pins vertical through hole

x = D pins bent for horizontal through hole mounting

**INNOLINE**  
DC/DC-Converter  
with 3 year Warranty

**RECOM**

**2, 3, 4 AMP**  
**SIP12**  
**Vertical &**  
**Horizontal**



**EN-60950-1 Certified**

**R-7xxx**

**Specifications (refer to the standard application circuit, Ta: 25°C)**

| Characteristics   | Conditions   | Min.   | Typ.               | Max.   |
|---|--|--|--------------------|--|
| Output Voltage Range                                      | All Series   | 2.5  |                    | 17V  |
| Output Current  | R-72xxP/D<br>R-73xxP/D<br>R-74xxP/D  | 0.2<br>0.3<br>0.4  |                    | 2.0A<br>3.0A<br>4.0A                                       |
| Output Current Limit                                      | R-72xxP/D<br>R-73xxP/D<br>R-74xxP/D  |  | 2.5<br>3.75<br>5.0 | 3.0A<br>4.25A<br>5.5A                                      |
| Short Circuit Input Current                               | All Series   |  | 50                 | 100mA  |
| Short Circuit Protection                                  |  | Continuous, automatic recovery                                 |                    |  |
| Output Voltage Accuracy (At 100% Load)                    | All Series   |  | ±1%                | ±2%  |
| Line Voltage Regulation (Vin = min. to max. at full load) | All Series   |  | 0.5                | 1.0%   |
| Load Regulation (10 to 100% full load)                    | All Series   |  | 0.5                | 1.0%   |
| Ripple & Noise  | All Series   |  | 40mVp-p            | 70mVp-p  |
| Transient Response (see note 1)                           | 50% Load Change –<br>Vout Over / Undershoot  |  | 100µs              | 200µs<br>100mV   |
| Remote ON / OFF (see note 2)                              | Open or High (Power ON)<br>Low (Power OFF)   | 4.5  |                    | 28V<br>0.8V  |
| Max capacitance Load                                      | with normal start-up time, no external diodes<br>with <1 second start up time + diode protection circuit |  |                    | 200µF<br>6800µF  |
| Switching Frequency                                       |  | 270  | 300                | 330kHz   |
| Shutdown current  | ON / OFF Pin pulled low  |  |                    | 100µA  |
| Quiescent Current   | Vin = min. to max. at 0% load  |  |                    | 30mA   |
| Operating Temperature Range                               |  | -40°C  |                    | +85°C  |
| Operating Case Temperature                                |  |  |                    | +110°C   |
| Storage Temperature Range                                 |  | -40°C  |                    | +125°C   |
| Case Material   |  | Non-Conductive Black Plastic                                   |                    |  |
| Potting Material  |  | Epoxy (UL94V-0)  |                    |  |
| Thermal Impedance   | Natural Convection   |  |                    | 25°C/W   |
| Internal Power Dissipation                                | Ta < 60°C  |  |                    | 1.4W   |
| Package Weight  |  |  |                    | 9g   |
| Packing Quantity  |  |  |                    | 15 pcs per Tube  |
| MTBF (Nominal Vout, 100% load)                            | Tamb. = +25°C<br>Tamb. = +85°C   | } Detailed Information see<br>Application Notes chapter "MTBF" |                    | 749 x 10 <sup>3</sup> hours<br>150 x 10 <sup>3</sup> hours |

**Notes:**

- Requires a 100µF electrolytic or tantalum output capacitor for proper operation in all applications (the capacitor to be placed as close as possible to the output pins).
- ON / OFF pin driven by TTL (logic gate), open-collector bipolar transistor or open-drain MOSFET.

**Output Current vs Input Voltage**

**How to calculate the max output current**

The internal power dissipation(P<sub>D</sub>)follows the equation:

$$P_D = I_o \times V_o \times (1-\eta)$$

$$I_o = P_D / V_o \times (1-\eta)$$

Where P<sub>D</sub> = Internal power dissipation  
I<sub>o</sub> = Output current  
V<sub>o</sub> = Output voltage  
η = Efficiency

Example: R-745.0P , at Vin = 28Vdc , Vo = 5Vdc , η=91% (see "Selection Guide" table)

(a) When Ta = 60°C , P<sub>D</sub> = 1.4 Watt (see beside diagram)

$$I_o = 1.4(W) / 5(V) \times (1-0.91) = 3.11(A)$$

(b) When Ta = 85°C , P<sub>D</sub> = 1 Watt (see beside diagram)

$$I_o = 1(W) / 5(V) \times (1-0.91) = 2.222(A)$$

(c) At Vin = 12Vdc efficiency = 94% (see "Selection Guide" table)

When Ta = 85°C , P<sub>D</sub> = 1 Watt (see beside diagram)

$$I_o = 1(W) / 5(V) \times (1-0.94) = 3.33(A)$$

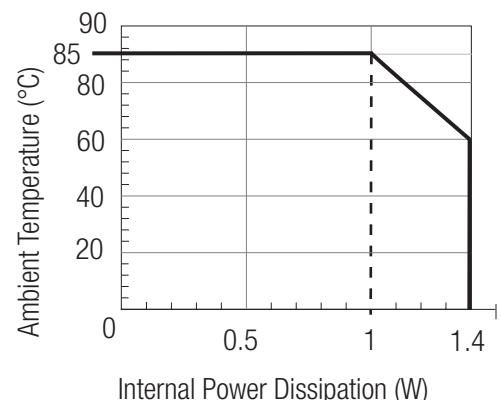

## Characteristics

R-72xx / R-73xx  
Ripple VS Vin

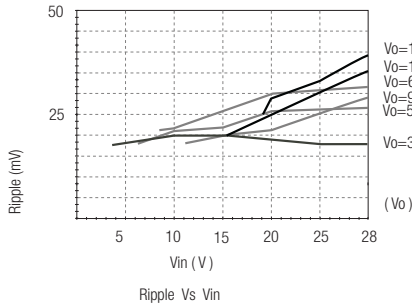

R-74xx  
Ripple VS Vin

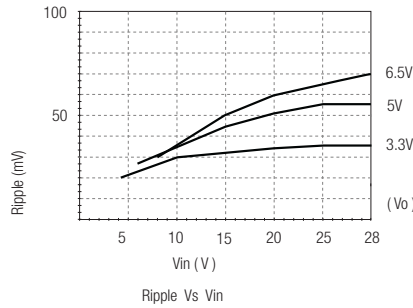

R-72xx / R-73xx  
Efficiency VS Vin

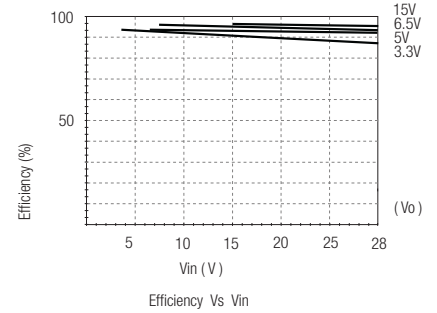

R-74xx  
Efficiency VS Vin

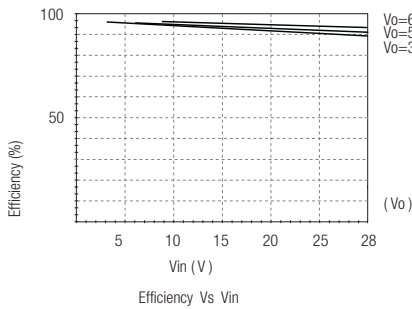

R-72xx / R-73xx / R-74xx  
Efficiency / Load Vin=Min

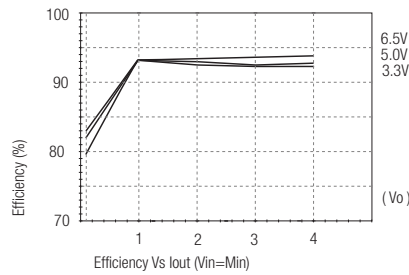

R-72xx / R-73xx / R-74xx  
Efficiency / Load Vin=Max

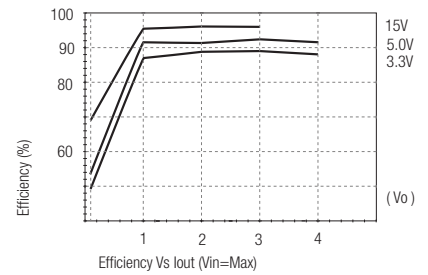

## Package Style and Pinning (mm)

SIP12 PIN Package

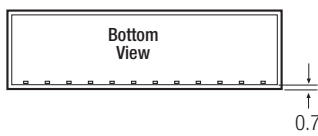
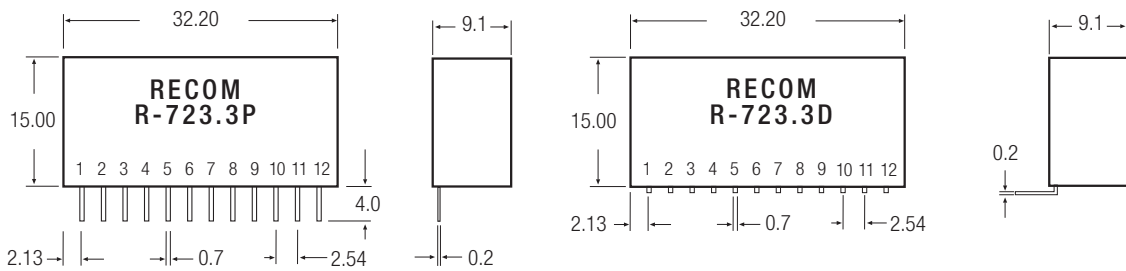

Tolerance:  $\pm 0.25$  mm

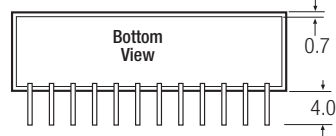

Pin Connections

| Pin #      | Name     | Description   |
|------------|----------|---|
| 1          | ON / OFF | Input pin : Active low (less than 0.8V) to disable the device |
| 2, 3, 4    | Vin      | Power input   |
| 5, 6, 7, 8 | GND      | Input and output ground (common)                              |
| 9, 10, 11  | Vout     | Power output  |
| 12         | Vout-Adj | With external resistors R1,R2 to selected output voltage      |

**Table 1: Adjustment Resistor Values**

| 2ADC           | R-723.3P/D | R-725.0P/D | R-726.5P/D | R-729.0P/D | R-7212P/D | R-7215P/D |        |       |       |       |       |       |
|----------------|------------|------------|------------|------------|-----------|-----------|--------|-------|-------|-------|-------|-------|
| 3ADC           | R-733.3P/D | R-735.0P/D | R-736.5P/D | R-739.0P/D | R-7312P/D | R-7315P/D |        |       |       |       |       |       |
| 4ADC           | R-743.3P/D | R-745.0P/D | R-746.5P/D |            |           |           |        |       |       |       |       |       |
| Vout (nominal) | 3.3Vdc     |            | 5.0Vdc     |            | 6.5Vdc    |           | 9.0Vdc |       | 12Vdc |       | 15Vdc |       |
| Vout (adj)     | R1         | R2         | R1         | R2         | R1        | R2        | R1     | R2    | R1    | R2    | R1    | R2    |
| 2.5            | 8.5KΩ      |            |            |            |           |           |        |       |       |       |       |       |
| 3.0            | 33KΩ       |            | 470Ω       |            |           |           |        |       |       |       |       |       |
| 3.2            | 110KΩ      |            | 1.6KΩ      |            |           |           |        |       |       |       |       |       |
| 3.3            |            |            | 2.2KΩ      |            |           |           |        |       |       |       |       |       |
| 3.4            |            | 36KΩ       | 3.0KΩ      |            |           |           |        |       |       |       |       |       |
| 3.6            |            | 11KΩ       | 4.7KΩ      |            |           |           |        |       |       |       |       |       |
| 3.9            |            | 4.7KΩ      | 8.5KΩ      |            |           |           |        |       |       |       |       |       |
| 4.5            |            | 1.6KΩ      | 30KΩ       |            |           |           |        |       |       |       |       |       |
| 4.9            |            | 820Ω       | 220KΩ      |            |           |           |        |       |       |       |       |       |
| 5.0            |            | 680Ω       |            |            | 11KΩ      |           |        |       |       |       |       |       |
| 5.1            |            | 560Ω       |            | 28KΩ       | 12KΩ      |           |        |       |       |       |       |       |
| 5.5            |            | 190Ω       |            | 2.6KΩ      | 20KΩ      |           |        |       |       |       |       |       |
| 6.0            |            |            |            |            | 47KΩ      |           |        |       |       |       |       |       |
| 6.5            |            |            |            |            |           |           |        |       |       |       |       |       |
| 7.0            |            |            |            |            |           | 560Ω      | 13KΩ   |       |       |       |       |       |
| 8.0            |            |            |            |            |           | 330Ω      | 31KΩ   |       |       |       |       |       |
| 9.0            |            |            |            |            |           |           |        |       |       |       |       |       |
| 10             |            |            |            |            |           |           |        | 2.2KΩ | 20KΩ  |       |       |       |
| 11             |            |            |            |            |           |           |        | 390Ω  | 47KΩ  |       |       |       |
| 12             |            |            |            |            |           |           |        |       |       |       |       |       |
| 13             |            |            |            |            |           |           |        |       |       | 2.4KΩ | 36KΩ  |       |
| 14             |            |            |            |            |           |           |        |       |       | 390Ω  | 76KΩ  |       |
| 15             |            |            |            |            |           |           |        |       |       |       |       |       |
| 16             |            |            |            |            |           |           |        |       |       |       |       | 2.6KΩ |
| 17             |            |            |            |            |           |           |        |       |       |       |       | 860Ω  |
| 18             |            |            |            |            |           |           |        |       |       |       |       |       |

R-7xxx

**Standard Application Circuit**

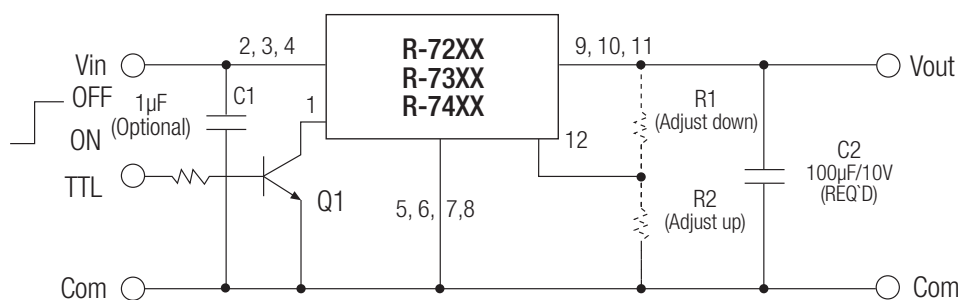

Add a blocking diode to Vout if current can flow backwards into the output, as this can damage the converter.

Protection diodes are required for high capacitive loads.

Refer to R-5xxxA Datasheet (see Optional Diode Protection Circuit) for circuit suggestions.