

Multimedia DAC with Class D Headphone and Line Out

DESCRIPTION

The WM8986 is a low power, high quality, feature-rich stereo DAC designed for portable multimedia applications that require low power consumption and high quality audio.

The device integrates preamps for stereo differential mics, and includes class D and class AB drivers for headphone and differential or stereo line output. External component requirements are reduced as no separate microphone or headphone amplifiers are required.

Advanced DSP features include a 5-band equaliser and a digital playback limiter. Highly flexible mixers enable many new application features, with the option to playback any combination of voice, line inputs and digital audio such as FM Radio or MP3.

The WM8986 digital audio interface can operate in master or slave mode, while an integrated PLL provides flexible clocking schemes.

The WM8986 operates at analogue supply voltages from 2.5V to 3.3V, although the digital core can operate at voltages down to 1.71V to save power. Additional power management control enables individual sections of the chip to be powered down under software control.

FEATURES

Stereo DAC:

- DAC SNR 100dB, THD -86dB ('A' weighted @ 48kHz)
- Headphone driver with 'capless' option
 - 40mW/channel output power into 16Ω / 3.3V AVDD2
 - Class D headphone driver
 - Class AB headphone / line Driver
 - PSRR 70dB at 217Hz
- Stereo, mono or differential line output

Mic Preamps:

- Stereo differential or mono microphone interfaces
- Programmable preamp gain
- Pseudo differential inputs with common mode rejection

Other Features:

- Enhanced 3-D function for improved stereo separation
- Digital playback limiter
- 5-band Equaliser
- Aux inputs for stereo analog input signals or 'beep'
- PLL supporting various clocks between 8MHz-50MHz
- Sample rates supported (kHz): 8, 11.025, 16, 12, 16, 22.05, 24, 32, 44.1, 48
- Low power, low voltage
- 2.5V to 3.6V analogue supplies
- 1.71V to 3.6V digital supplies
- 4x4mm 28-lead COL QFN package

APPLICATIONS

- Portable audio player / FM radio
- Multimedia Mobile Handsets

BLOCK DIAGRAM

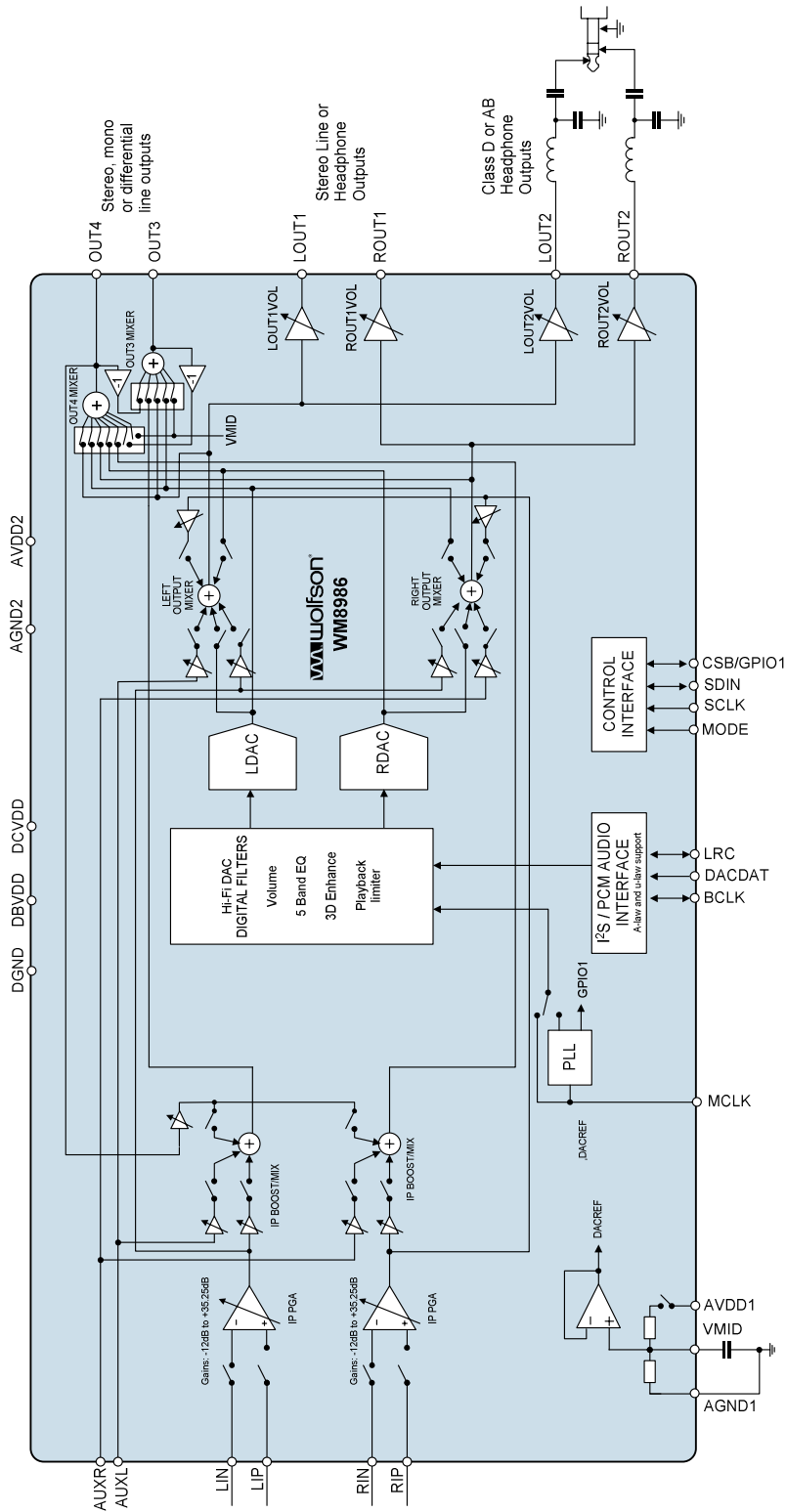
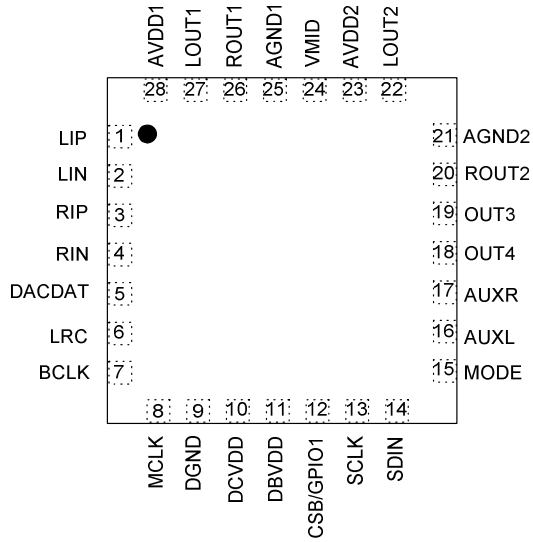

TABLE OF CONTENTS

DESCRIPTION	1
FEATURES	1
APPLICATIONS	1
BLOCK DIAGRAM	2
TABLE OF CONTENTS	3
PIN CONFIGURATION	4
ORDERING INFORMATION	4
PIN DESCRIPTION	5
ABSOLUTE MAXIMUM RATINGS	6
RECOMMENDED OPERATING CONDITIONS	6
ELECTRICAL CHARACTERISTICS	7
TERMINOLOGY	11
AUDIO PATHS OVERVIEW	12
SIGNAL TIMING REQUIREMENTS	14
SYSTEM CLOCK TIMING	14
AUDIO INTERFACE TIMING – MASTER MODE	14
AUDIO INTERFACE TIMING – SLAVE MODE.....	15
CONTROL INTERFACE TIMING – 3-WIRE MODE	16
CONTROL INTERFACE TIMING – 2-WIRE MODE	17
INTERNAL POWER ON RESET CIRCUIT	18
RECOMMENDED POWER UP/DOWN SEQUENCE	20
DEVICE DESCRIPTION	22
INTRODUCTION.....	22
INPUT SIGNAL PATH	23
OUTPUT SIGNAL PATH	31
3D STEREO ENHANCEMENT	37
ANALOGUE OUTPUTS.....	37
DIGITAL AUDIO INTERFACES.....	50
AUDIO SAMPLE RATES	54
MASTER CLOCK AND PHASE LOCKED LOOP (PLL).....	55
COMPANDING.....	58
GENERAL PURPOSE INPUT/OUTPUT	60
OUTPUT SWITCHING (JACK DETECT).....	61
CONTROL INTERFACE.....	62
RESETTING THE CHIP	63
POWER SUPPLIES	63
POWER MANAGEMENT	64
REGISTER MAP	65
REGISTER BITS BY ADDRESS	67
DAC DIGITAL FILTER CHARACTERISTICS	80
TERMINOLOGY	80
DAC FILTER RESPONSES.....	81
5-BAND EQUALISER.....	82
APPLICATIONS INFORMATION	86
RECOMMENDED EXTERNAL COMPONENTS	86
PACKAGE DIAGRAM	87
IMPORTANT NOTICE	88
ADDRESS:	88

PIN CONFIGURATION



ORDERING INFORMATION

ORDER CODE	TEMPERATURE RANGE	PACKAGE	MOISTURE SENSITIVITY LEVEL	PEAK SOLDERING TEMPERATURE
WM8986GECO/V	-40°C to +85°C	28-lead COL QFN (4 x 4 mm) (Pb-free)	MSL3	260°C
WM8986GECO/RV	-40°C to +85°C	28-lead COL QFN (4 x 4 mm) (Pb-free, tape and reel)	MSL3	260°C

Note:

Reel quantity = 3,500

PIN DESCRIPTION

PIN	NAME	TYPE	DESCRIPTION
1	LIP	Analogue input	Left MIC pre-amp positive input
2	LIN	Analogue input	Left MIC pre-amp negative input
3	RIP	Analogue input	Right MIC pre-amp positive input
4	RIN	Analogue input	Right MIC pre-amp negative input
5	DACDAT	Digital Input	DAC digital audio data input
6	LRC	Digital Input / Output	DAC sample rate clock
7	BCLK	Digital Input / Output	Digital audio bit clock
8	MCLK	Digital Input	Master clock input
9	DGND	Supply	Digital ground
10	DCVDD	Supply	Digital core logic supply
11	DBVDD	Supply	Digital buffer (I/O) supply
12	CSB/GPIO1	Digital Input / Output	3-Wire control interface chip Select / GPIO1 pin
13	SCLK	Digital Input	3-Wire control interface clock input / 2-wire control interface clock input
14	SDIN	Digital Input / Output	3-Wire control interface data input / 2-Wire control interface data input
15	MODE	Digital Input	Control interface selection
16	AUXL	Analogue input	Left auxiliary input
17	AUXR	Analogue input	Right auxiliary input
18	OUT4	Analogue Output	Right line output / mono mix output
19	OUT3	Analogue Output	Left line output
20	ROUT2	Analogue Output	Class D or class AB headphone output right
21	AGND2	Supply	Analogue ground (ground reference for ROUT2/LOUT2 and OUT3/OUT4)
22	LOUT2	Analogue Output	Class D or class AB headphone output left
23	AVDD2	Supply	Analogue supply (feeds output amplifiers ROUT2/LOUT2 and OUT3/OUT4)
24	VMID	Reference	Decoupling for DAC reference voltage
25	AGND1	Supply	Analogue ground (ground reference for all input amplifiers, PLL, DAC, intern bias circuits, output amplifiers LOUT1, ROUT1)
26	ROUT1	Analogue Output	Class AB headphone or line output right
27	LOUT1	Analogue Output	Class AB headphone or line output left
28	AVDD1	Supply	Analogue supply (feeds all input amplifiers, PLL, DAC, internal bias circuits, output amplifiers LOUT1, ROUT1)

ABSOLUTE MAXIMUM RATINGS

Absolute Maximum Ratings are stress ratings only. Permanent damage to the device may be caused by continuously operating at or beyond these limits. Device functional operating limits and guaranteed performance specifications are given under Electrical Characteristics at the test conditions specified.



ESD Sensitive Device. This device is manufactured on a CMOS process. It is therefore generically susceptible to damage from excessive static voltages. Proper ESD precautions must be taken during handling and storage of this device.

Wolfson tests its package types according to IPC/JEDEC J-STD-020B for Moisture Sensitivity to determine acceptable storage conditions prior to surface mount assembly. These levels are:

MSL1 = unlimited floor life at <30°C / 85% Relative Humidity. Not normally stored in moisture barrier bag.

MSL2 = out of bag storage for 1 year at <30°C / 60% Relative Humidity. Supplied in moisture barrier bag.

MSL3 = out of bag storage for 168 hours at <30°C / 60% Relative Humidity. Supplied in moisture barrier bag.

The Moisture Sensitivity Level for each package type is specified in Ordering Information.

CONDITION	MIN	MAX
DBVDD, DCVDD, AVDD1, AVDD2 supply voltages	-0.3V	+4.5V
Voltage range digital inputs	DGND -0.3V	DBVDD +0.3V
Voltage range analogue inputs	AGND1 -0.3V	AVDD1 +0.3V
Operating Temperature Range	-40°C	+85°C
Storage temperature prior to soldering	30°C max / 85% RH max	
Storage temperature after soldering	-65°C	+150°C

Notes:

1. Analogue and digital grounds must always be within 0.3V of each other.
2. All digital and analogue supplies are internally independent (i.e. not connected).
3. Analogue supply voltages AVDD1 and AVDD2 should be greater than or equal to the DCVDD digital supply voltage.
4. DBVDD must be greater than or equal to DCVDD.

RECOMMENDED OPERATING CONDITIONS

PARAMETER	SYMBOL	TEST CONDITIONS	MIN	TYP	MAX	UNIT
Digital supply range (Core)	DCVDD		1.71 ¹		3.6	V
Digital supply range (Buffer)	DBVDD		1.71		3.6	V
Analogue supply range	AVDD1, AVDD2		2.5 ¹		3.6	V
Ground	DGND, AGND1, AGND2			0		V

Notes:

1. Analogue supply voltages should not be less than digital supply voltages.
2. DBVDD must be greater than or equal to DCVDD.

ELECTRICAL CHARACTERISTICS

Test Conditions

DCVDD=1.8V, AVDD1=AVDD2=DBVDD=3.3V, T_A = +25°C, 1kHz signal, fs = 48kHz, 24-bit audio data unless otherwise stated.

PARAMETER	SYMBOL	TEST CONDITIONS	MIN	TYP	MAX	UNIT
Microphone Input PGA Inputs (LIP, LIN, RIP, RIN)						
INPPGAVOLL, INPPGAVOLR, PGABOOSTL and PGABOOSTR = 0dB						
Full-scale Input Signal Level – Single-ended input via LIN/RIN ¹				AVDD/3.3		V _{rms}
Full-scale Input Signal Level – Pseudo-differential input ^{1,2}				AVDD*0.7/ 3.3		V _{rms}
Input PGA equivalent input noise		INPPGAVOLL/R = +35.25dB No input signal 0 to 20kHz		150		µV
LIN, RIN input resistance		INPPGAVOLL and INPPGAVOLR = +35.25dB		1.6		kΩ
LIN, RIN input resistance		INPPGAVOLL and INPPGAVOLR = 0dB		46		kΩ
LIN, RIN input resistance		INPPGAVOLL and INPPGAVOLR = -12dB		71		kΩ
LIP, RIP input resistance		All gain settings		90		kΩ
Input Capacitance		All analogue input pins		10		pF
Input PGA Programmable Gain		Gain adjusted by INPPGAVOLL and INPPGAVOLL	-12		+35.25	dB
Programmable Gain Step Size		Guaranteed monotonic		0.75		dB
Input PGA Mute Attenuation		INPPGAMUTEL and INPPGAMUTER = 1		100		dB
Input Gain Boost		PGABOOSTL and PGABOOSTR = 0		0		dB
Input Gain Boost		PGABOOSTL and PGABOOSTR = 1		+20		dB
Auxiliary Analogue Inputs (AUXL, AUXR)						
Full-scale Input Signal Level ²				AVDD/3.3		V _{rms}
Input Resistance		Left Input boost and mixer enabled, at +6dB		11		kΩ
		Left Input boost and mixer enabled, at 0dB gain		22		kΩ
		Left Input boost and mixer enabled, at -12dB gain		60		kΩ
		Right Input boost, mixer enabled, at +6dB gain		11		kΩ
		Right Input boost, mixer enabled, at 0dB gain		22		kΩ
		Right Input boost, mixer enabled, at -12dB gain		60		kΩ
Input Capacitance		All analogue Inputs		10		pF
Gain range from AUXL and AUXR input to left and right input PGA mixers		Gain adjusted by AUXL2BOOSTVOL and AUXR2BOOSTVOL	-12		+6	dB
AUXLBOOSTVOL and AUXRBOOSTVOL step size				3		dB

Test ConditionsDCVDD=1.8V, AVDD1=AVDD2=DBVDD=3.3V, T_A = +25°C, 1kHz signal, f_s = 48kHz, 24-bit audio data unless otherwise stated.

PARAMETER	SYMBOL	TEST CONDITIONS	MIN	TYP	MAX	UNIT
DAC to left and right mixers into 10kΩ / 50pF load on LOUT1 and ROUT1 LOUT1VOL, ROUT1VOL, DACLVOL and DACRVOL = 0dB						
Full-scale output ¹		LOUT1VOL and ROUTVOL = 0dB		AVDD1/3.3		V _{rms}
Signal to Noise Ratio ³	SNR	A-weighted AVDD1=AVDD2=3.3V	90	100		dB
		A-weighted AVDD1=AVDD2=2.5V		96		dB
		22Hz to 20kHz AVDD1=AVDD2=3.3V		95.5		dB
		22Hz to 20kHz AVDD1=AVDD2=2.5V		93.5		dB
Total Harmonic Distortion ⁴	THD	0dBFS input AVDD1=AVDD2=3.3V		-86	-80	dBFS
		0dBFS input AVDD1=AVDD2=2.5V		-86		dBFS
Total Harmonic Distortion + Noise ⁵	THD+N	0dBFS input AVDD1=AVDD2=3.3V		-84	-78	dBFS
		0dBFS input AVDD1=AVDD2=2.5V		-84		dBFS
Channel Separation ⁶		1kHz signal		100		dB
DAC to L/R mixer into 10kΩ / 50pF load on L/ROUT2, class AB mode LOUT2VOL, ROUT2VOL, DACLVOL and DACRVOL = 0dB						
Full-scale output ¹		LOUT2VOL and ROUT2VOL = 0dB		AVDD1/3.3		V _{rms}
Signal to Noise Ratio ³	SNR	A-weighted AVDD1=AVDD2=3.3V	90	100		dB
		A-weighted AVDD1=AVDD2=2.5V		96		dB
		22Hz to 20kHz AVDD1=AVDD2=3.3V		95.5		dB
		22Hz to 20kHz AVDD1=AVDD2=2.5V		93.5		dB
Total Harmonic Distortion ⁴	THD	0dBFS input AVDD1=AVDD2=3.3V		-86	-80	dBFS
		0dBFS input AVDD1=AVDD2=2.5V		-82		dBFS
Total Harmonic Distortion + Noise ⁵	THD+N	0dBFS input AVDD1=AVDD2=3.3V		-84	-78	dBFS
		0dBFS input AVDD1=AVDD2=2.5V		-80		dBFS
Channel Separation ⁶		1kHz input signal		100		dB
DAC to OUT3 and OUT4 mixers to OUT3/OUT4 outputs into 10kΩ / 50pF load. DACVOLL and DACVOLR = 0dB						
Full-scale output voltage				AVDD2/3.3		V _{rms}
Signal to Noise Ratio ³	SNR	A-weighted AVDD1=AVDD2=3.3V	90	100		dB
		22Hz to 22kHz AVDD1=AVDD2=3.3V		96		dB
Total Harmonic Distortion ⁴	THD	full-scale signal AVDD1=AVDD2=3.3V		-87	-80	dBFS
Total Harmonic Distortion + Noise ⁵	THD+N	full-scale signal AVDD1=AVDD2=3.3V		-85	-78	dBFS
		full-scale signal		-80		dBFS

Test ConditionsDCVDD=1.8V, AVDD1=AVDD2=DBVDD=3.3V, T_A = +25°C, 1kHz signal, fs = 48kHz, 24-bit audio data unless otherwise stated.

PARAMETER	SYMBOL	TEST CONDITIONS	MIN	TYP	MAX	UNIT
		AVDD1=AVDD2=2.5V				
Channel Separation ⁶		1kHz signal		100		dB
DAC to left and right mixer into headphone (16Ω load on LOUT1 and ROUT1 LOUT1VOL, ROUT1VOL, DACLVOL and DACRVOL = 0dB						
Full-scale output				AVDD1/3.3		V _{rms}
Signal to Noise Ratio ³	SNR	A-weighted		100		dB
		22Hz to 20kHz		95.5		dB
Total Harmonic Distortion ⁴	THD	P _o = 20mW, RL=16Ω		-75		dB
Total Harmonic Distortion + Noise ⁵	THD+N	P _o = 20mW, RL=16Ω		-75		dB
Channel Separation ⁶		1kHz signal		100		dB
DAC to left and right mixer into headphone (16Ω load) on LOUT2 and ROUT2, Class AB mode LOUT2VOL, ROUT2VOL, DACLVOL and DACRVOL = 0dB						
Full-scale output				AVDD1/3.3		V _{rms}
Signal to Noise Ratio ³	SNR	A-weighted	90	97		dB
		22Hz to 20kHz		95.5		dB
Total Harmonic Distortion ⁴	THD	P _o = 20mW, RL=16Ω		-84	-75	dB
Total Harmonic Distortion + Noise ⁵	THD+N	P _o = 20mW, RL=16Ω		-81	-70	dB
Channel Separation ⁶		1kHz signal		100		dB
DAC to left and right mixer into headphone load on LOUT2 and ROUT2, Class D mode, L_{filter} = 33uH C_{filter} = 220nf LOUT2VOL, ROUT2VOL, DACLVOL and DACRVOL = 0dB						
Full-scale output		L/ROUT2VOL = 0dB		AVDD1/3.3		V _{rms}
Signal to Noise Ratio ³	SNR	A-weighted	80	90		dB
Total Harmonic Distortion ⁴	THD	P _o = 20mW, RL=16Ω		-78	-70	dB
Total Harmonic Distortion + Noise ⁵	THD+N	P _o = 20mW, RL=16Ω		-74	-70	dB
Channel Separation ⁶		1kHz signal		100		dB
PWM Rise Time				1.5		ns
PWM Fall Time				1.5		ns
PWM Switching Frequency		DCLKDIV = 1000		1.4		MHz
Efficiency		R _L = 16Ω, t _{PW} = 20ns, P _O = 20mW		72		%
Power Supply Rejection	PSRR	100mV _{pp} ripple @217Hz injected on AVDD2		70		dB
Idle Current		No analogue output signal on either channel		0.5		mA
PGA outputs to left and right output mixers. BYPL2LMIX = 1 and BYPR2RMIX = 1						
PGA gain range into mixer		Gain adjusted by BYPLMIXVOL and BYPRMIXVOL	-15	0	+6	dB
BYPLMIXVOL and BYPRMIXVOL gain step into mixer				3		dB
Mute attenuation		BYPL2LMIX = 0 BYPR2RMIX = 0		100		dB
Analogue outputs (LOUT1, ROUT1, LOUT2, ROUT2)						
Programmable Gain range		Gain adjusted by L/ROUT1VOL and L/ROUT2VOL	-57	0	+6	dB
Programmable Gain step size		Monotonic		1		dB
Mute attenuation		1kHz, full scale signal L/ROUT1MUTE = 1 L/ROUT2MUTE = 1		85		dB

Test ConditionsDCVDD=1.8V, AVDD1=AVDD2=DBVDD=3.3V, T_A = +25°C, 1kHz signal, fs = 48kHz, 24-bit audio data unless otherwise stated.

PARAMETER	SYMBOL	TEST CONDITIONS	MIN	TYP	MAX	UNIT
AUXL and AUXR into on OUT3/OUT4 outputs on 10kΩ / 50pF load INPPGAVOLL, INPPGAVOLR = 0dB						
Full-scale output voltage, 0dB gain				AVDD2/3.3		V _{rms}
Signal to Noise Ratio ³	SNR	A-weighted AVDD1=AVDD2=3.3V	85	98		dB
		A-weighted AVDD1=AVDD2=2.5V		96		dB
		22Hz to 22kHz AVDD1=AVDD2=3.3V		95.5		dB
		22Hz to 22kHz AVDD1=AVDD2=2.5V		93.5		dB
Total Harmonic Distortion ⁴	THD	full-scale signal AVDD1=AVDD2=3.3V		-90	-80	dB
		full-scale signal AVDD1=AVDD2=2.5V		-82		dB
Total Harmonic Distortion + Noise ⁵	THD+N	full-scale signal AVDD1=AVDD2=3.3V		-86	-78	dB
		full-scale signal AVDD1=AVDD2=2.5V		-80		dB
Channel Separation ⁶				100		dB
LIN and RIN into input PGA into LOUT1 and ROUT1 into 16Ω / 50pF loads BYPLMIXVOL, BYPRMIXVOL, LOUT1VOL and ROUT1VOL = 0dB						
Full-scale output voltage, 0dB gain				AVDD1/3.3		V _{rms}
Signal to Noise Ratio ³	SNR	A-weighted AVDD1=AVDD2=3.3V	85	100		dB
		A-weighted AVDD1=AVDD2=2.5V		96		dB
		22Hz to 22kHz AVDD1=AVDD2=3.3V		95.5		dB
		22Hz to 22kHz AVDD1=AVDD2=2.5V		93.5		dB
Total Harmonic Distortion ⁴	THD	P _o = 20mW, RL=16Ω AVDD1=AVDD2=3.3V		-87	-73	dB
Total Harmonic Distortion + Noise ⁵	THD+N	P _o = 20mW, RL=16Ω AVDD1=AVDD2=3.3V		-85	-70	dB
Channel separation ⁶		1kHz full scale signal		100		dB
LIN and RIN into input PGA into OUT3 and OUT4 into 10kΩ / 50pF loads INPPGAVOLL, INPPGAVOLR = 0dB						
Full-scale output voltage				AVDD2/3.3		V _{rms}
Signal to Noise Ratio ³	SNR	A-weighted AVDD1=AVDD2=3.3V		100		dB
	SNR	22Hz to 22kHz AVDD1=AVDD2=3.3V		95.5		dB
Total Harmonic Distortion ⁴	THD	full-scale signal AVDD1=AVDD2=3.3V		-87		dB
Total Harmonic Distortion + Noise ⁵	THD+N	full-scale signal AVDD1=AVDD2=3.3V		-85		dB
Channel Separation ⁶		1kHz signal		100		dB

Test ConditionsDCVDD=1.8V, AVDD1=AVDD2=DBVDD=3.3V, T_A = +25°C, 1kHz signal, fs = 48kHz, 24-bit audio data unless otherwise stated.

PARAMETER	SYMBOL	TEST CONDITIONS	MIN	TYP	MAX	UNIT
Digital Input / Output						
Input HIGH Level	V _{IH}		0.7×DBV DD			V
Input LOW Level	V _{IL}				0.3×DBVDD	V
Output HIGH Level	V _{OH}	I _{OL} =1mA	0.9×DBV DD			V
Output LOW Level	V _{OL}	I _{OH} =1mA			0.1×DBVDD	V
Input Capacitance		All digital pins		10		pF
Input leakage				11		pA

TERMINOLOGY

1. Full-scale input and output levels scale in relation to AVDD or AVDD2 depending upon the input or output used. For example, when AVDD = 3.3V, 0dBFS = 1V_{rms} (0dBV). When AVDD < 3.3V the absolute level of 0dBFS will decrease with a linear relationship to AVDD.
2. Input level to RIP and LIP in differential configurations is limited to a maximum of -3dB or performance will be reduced.
3. Signal-to-noise ratio (dBFS) – SNR is the difference in level between a reference full scale output signal and the device output with no signal applied. This ratio is also called idle channel noise. (No Auto-zero or Automute function is employed in achieving these results).
4. Total Harmonic Distortion (dBFS) – THD is the difference in level between a reference full scale output signal and the first seven odd harmonics of the output signal. To calculate the ratio, the fundamental frequency of the output signal is notched out and an RMS value of the next seven harmonics is calculated.
5. Total Harmonic Distortion plus Noise (dBFS) – THD+N is the difference in level between a reference full scale output signal and the sum of the harmonics, wide-band noise and interference on the output signal. To calculate the ratio, the fundamental frequency of the output signal is notched out and an RMS value of the total harmonics, wide-band noise and interference is calculated.
6. Channel Separation (dB) – Also known as Cross-Talk. This is a measure of the amount one channel is isolated from the other. Normally measured by sending a full scale signal down one channel and measuring the other.

POWER CONSUMPTION

Typical power consumption for various scenarios is shown below.

All measurements are made with quiescent signal.

Description	DCVDD(V)	DCVDD(mA)	DBVDD(V)	DBVDD(mA)	AVDD1(V)	AVDD1(mA)	AVDD2(V)	AVDD2(mA)	Total (mW)
Off (Default Settings)	1.8	0.002	1.8	0	2.5	0.01	2.5	0	0.03
	1.8	0.002	3.3	0	3	0.011	3	0	0.04
	1.8	0.002	3.3	0	3.3	0.012	3.3	0	0.04
	3.3	0.006	3.3	0	3.3	0.011	3.3	0	0.06
	3.6	0.008	3.6	0	3.6	0.012	3.6	0	0.07
Standby mode (Lowest Power)	1.8	0.002	1.8	0	2.5	0.117	2.5	0	0.30
	1.8	0.002	3.3	0	3	0.138	3	0	0.42
	1.8	0.002	3.3	0	3.3	0.149	3.3	0	0.50
	3.3	0.006	3.3	0	3.3	0.149	3.3	0	0.51
	3.6	0.008	3.6	0	3.6	0.157	3.6	0	0.59
DAC Playback 32Ω load L/ROUT2 - Class AB Mode fs=44.1kHz	1.8	3.336	1.8	0.003	2.5	2.238	2.5	0.28	12.31
	1.8	3.336	3.3	0.0021	3	2.728	3	0.35	15.24
	3.3	7.182	3.3	0.0021	3.3	3.025	3.3	0.39	34.98
	3.6	8.098	3.6	0.025	3.6	3.325	3.6	0.44	42.80

Table 1 Power Consumption

Contact [Wolfson](#) for more information on device power consumption.

AUDIO PATHS OVERVIEW

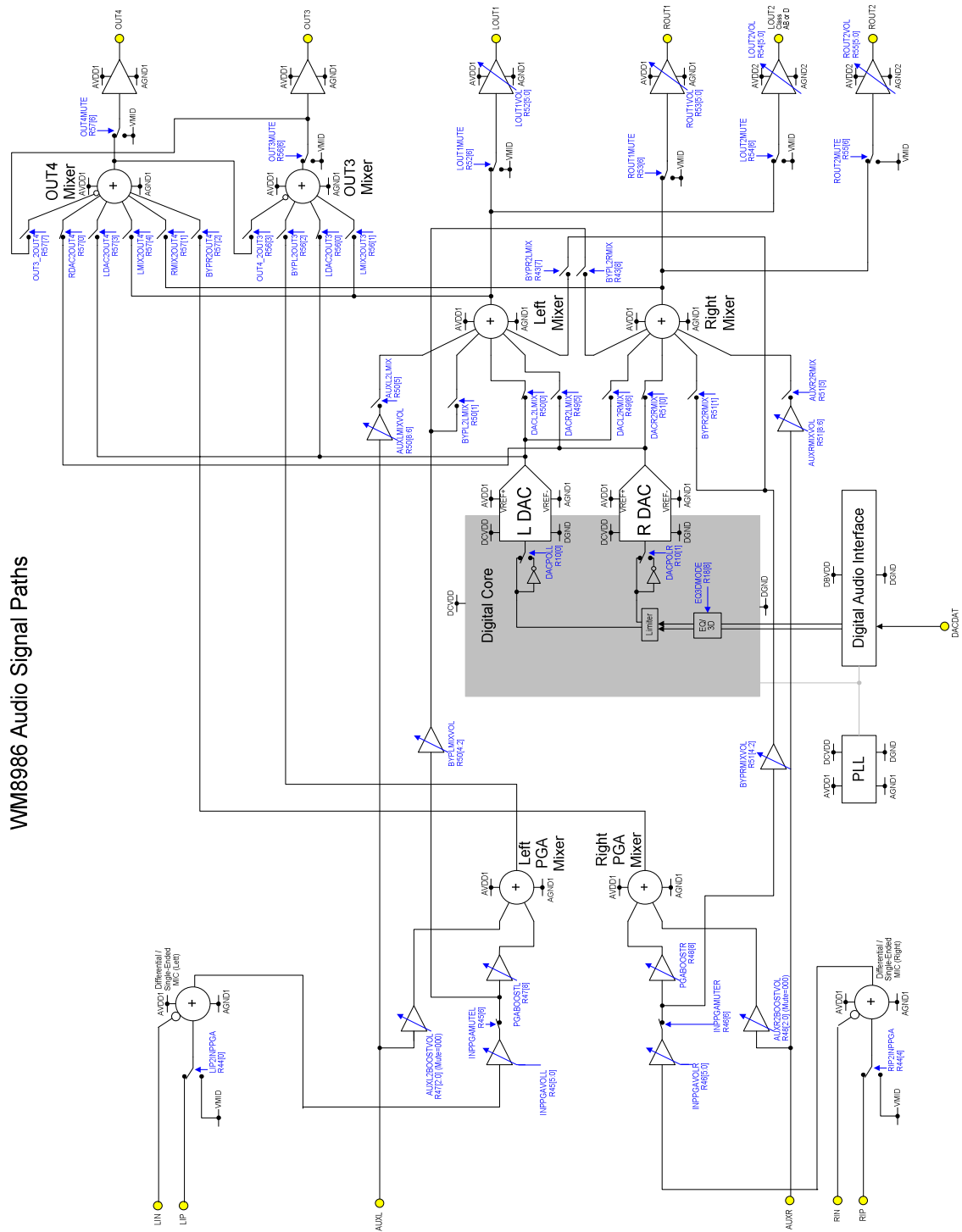

Figure 1 Audio Paths Overview

SIGNAL TIMING REQUIREMENTS

SYSTEM CLOCK TIMING

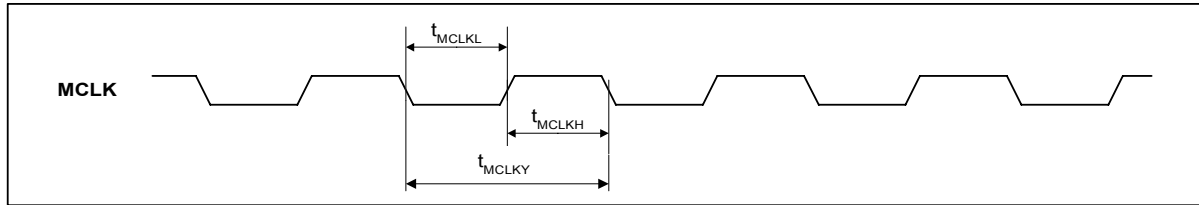

Figure 2 System Clock Timing Requirements

Test Conditions

DCVDD=1.8V, DBVDD=AVDD1=AVDD2=3.3V, DGND=AGND1=AGND2=0V, $T_A = +25^{\circ}\text{C}$, Slave Mode

PARAMETER	SYMBOL	CONDITIONS	MIN	TYP	MAX	UNIT
System Clock Timing Information						
MCLK cycle time	T_{MCLKY}	MCLK=SYSCLK (=256fs)	81.38			ns
		MCLK input to PLL ^{Note 1}	20			ns
MCLK duty cycle	T_{MCLKDS}		60:40		40:60	

Note:

1. PLL pre-scaling and PLL N and K values should be set appropriately so that SYSCLK is no greater than 12.288MHz.

AUDIO INTERFACE TIMING – MASTER MODE

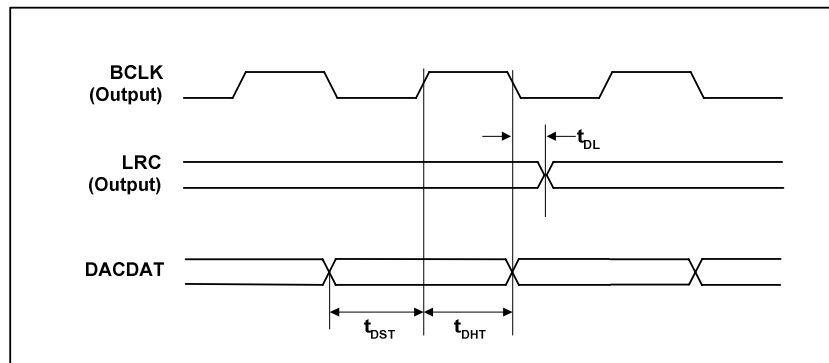

Figure 3 Digital Audio Data Timing – Master Mode (see Control Interface)

Test Conditions

DCVDD=1.8V, DBVDD=AVDD1=AVDD2=3.3V, DGND=AGND1=AGND2=0V, $T_A=+25^{\circ}\text{C}$, Master Mode, $f_s=48\text{kHz}$, MCLK=256fs, 24-bit data, unless otherwise stated.

PARAMETER	SYMBOL	MIN	TYP	MAX	UNIT
Audio Data Input Timing Information					
LRC propagation delay from BCLK falling edge	t_{DL}			10	ns
DACDAT setup time to BCLK rising edge	t_{DST}	10			ns
DACDAT hold time from BCLK rising edge	t_{DHT}	10			ns

AUDIO INTERFACE TIMING – SLAVE MODE

Figure 4 Digital Audio Data Timing – Slave Mode

Test Conditions

DCVDD=1.8V, DBVDD=AVDD1=AVDD2=3.3V, DGND=AGND1=AGND2=0V, $T_A=+25^{\circ}\text{C}$, Slave Mode, $f_s=48\text{kHz}$, MCLK= 256fs, 24-bit data, unless otherwise stated.

PARAMETER	SYMBOL	MIN	TYP	MAX	UNIT
Audio Data Input Timing Information					
BCLK cycle time	t_{BCY}	50			ns
BCLK pulse width high	t_{BCH}	20			ns
BCLK pulse width low	t_{BCL}	20			ns
LRC set-up time to BCLK rising edge	t_{LRSU}	10			ns
LRC hold time from BCLK rising edge	t_{LRH}	10			ns
DACDAT hold time from BCLK rising edge	t_{DH}	10			ns
DACDAT set-up time to BCLK rising edge	t_{Ds}	10			ns

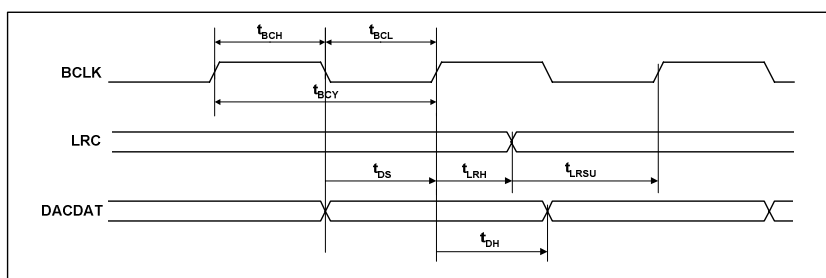
Note:

BCLK period should always be greater than or equal to MCLK period.

CONTROL INTERFACE TIMING – 3-WIRE MODE

3-wire mode is selected by connecting the MODE pin high.

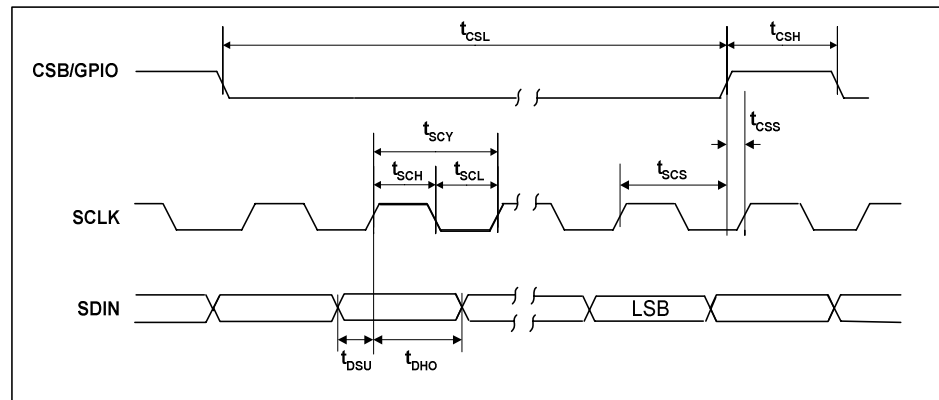

Figure 5 Control Interface Timing – 3-Wire Serial Control Mode

Test Conditions

DCVDD = 1.8V, DBVDD = AVDD1 = AVDD2 = 3.3V, DGND = AGND1 = AGND2 = 0V, T_A = +25°C, Slave Mode, fs = 48kHz, MCLK = 256fs, 24-bit data, unless otherwise stated.

PARAMETER	SYMBOL	MIN	TYP	MAX	UNIT
Program Register Input Information					
SCLK rising edge to CSB rising edge	t _{SCS}	80			ns
SCLK pulse cycle time	t _{SCY}	200			ns
SCLK pulse width low	t _{SCL}	80			ns
SCLK pulse width high	t _{SCH}	80			ns
SDIN to SCLK set-up time	t _{DSU}	40			ns
SCLK to SDIN hold time	t _{DHO}	40			ns
CSB pulse width low	t _{CSL}	40			ns
CSB pulse width high	t _{CSH}	40			ns
CSB rising to SCLK rising	t _{CSS}	40			ns
Pulse width of spikes that will be suppressed	t _{ps}	0		5	ns

CONTROL INTERFACE TIMING – 2-WIRE MODE

2-wire mode is selected by connecting the MODE pin low.

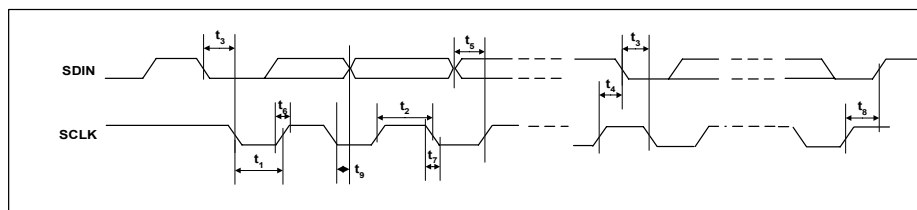

Figure 6 Control Interface Timing – 2-Wire Serial Control Mode

Test Conditions

DCVDD=1.8V, DBVDD=AVDD1=AVDD2=3.3V, DGND=AGND1=AGND2=0V, $T_A=+25^{\circ}\text{C}$, Slave Mode, $f_s=48\text{kHz}$, MCLK = 256fs, 24-bit data, unless otherwise stated.

PARAMETER	SYMBOL	MIN	TYP	MAX	UNIT
Program Register Input Information					
SCLK Frequency		0		526	kHz
SCLK Low Pulse-Width	t_1	1.3			us
SCLK High Pulse-Width	t_2	600			ns
Hold Time (Start Condition)	t_3	600			ns
Setup Time (Start Condition)	t_4	600			ns
Data Setup Time	t_5	100			ns
SDIN, SCLK Rise Time	t_6			300	ns
SDIN, SCLK Fall Time	t_7			300	ns
Setup Time (Stop Condition)	t_8	600			ns
Data Hold Time	t_9			900	ns
Pulse width of spikes that will be suppressed	t_{ps}	0		5	ns

INTERNAL POWER ON RESET CIRCUIT

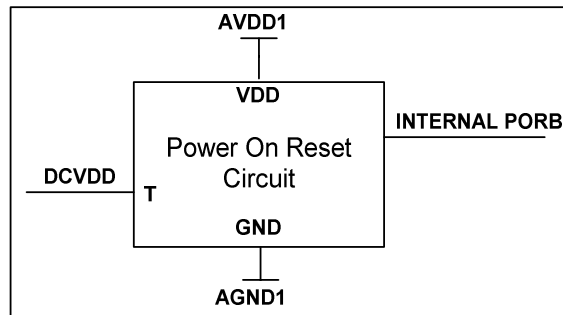

Figure 7 Internal Power on Reset Circuit Schematic

The WM8986 includes an internal Power-On-Reset Circuit, as shown in Figure 7, which is used to reset the digital logic into a default state after power up. The POR circuit is powered from AVDD1 and monitors DCVDD. It asserts PORB low if AVDD1 or DCVDD is below a minimum threshold.

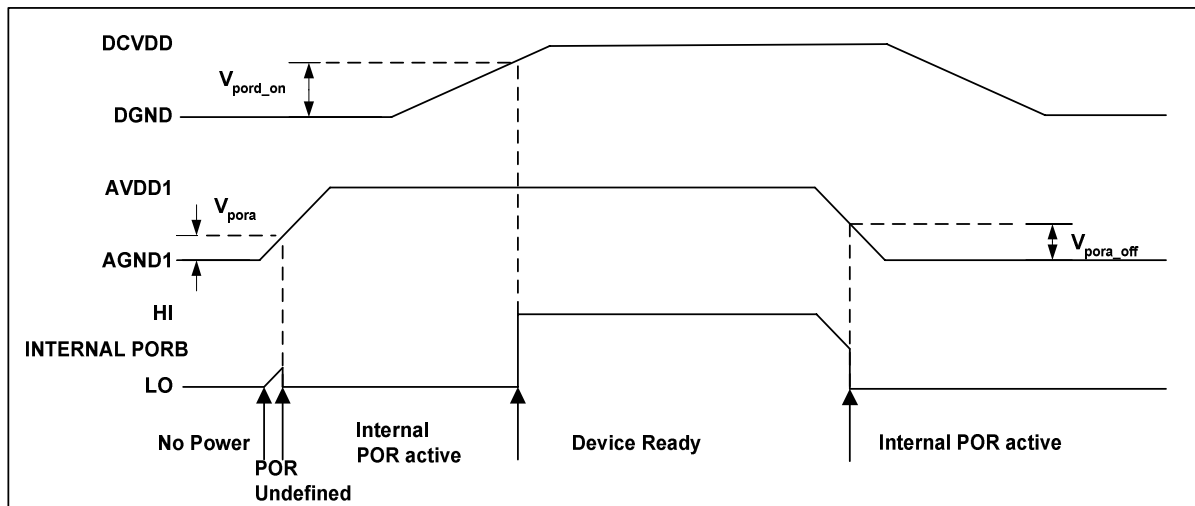

Figure 8 Typical Power up Sequence where AVDD1 is Powered before DCVDD

Figure 8 shows a typical power-up sequence where AVDD1 comes up first. When AVDD1 goes above the minimum threshold, V_{pora} , there is enough voltage for the circuit to guarantee PORB is asserted low and the chip is held in reset. In this condition, all writes to the control interface are ignored. Now AVDD1 is at full supply level. Next DCVDD rises to V_{pord_on} and PORB is released high and all registers are in their default state and writes to the control interface may take place.

On power down, where AVDD1 falls first, PORB is asserted low whenever AVDD1 drops below the minimum threshold V_{pora_off} .

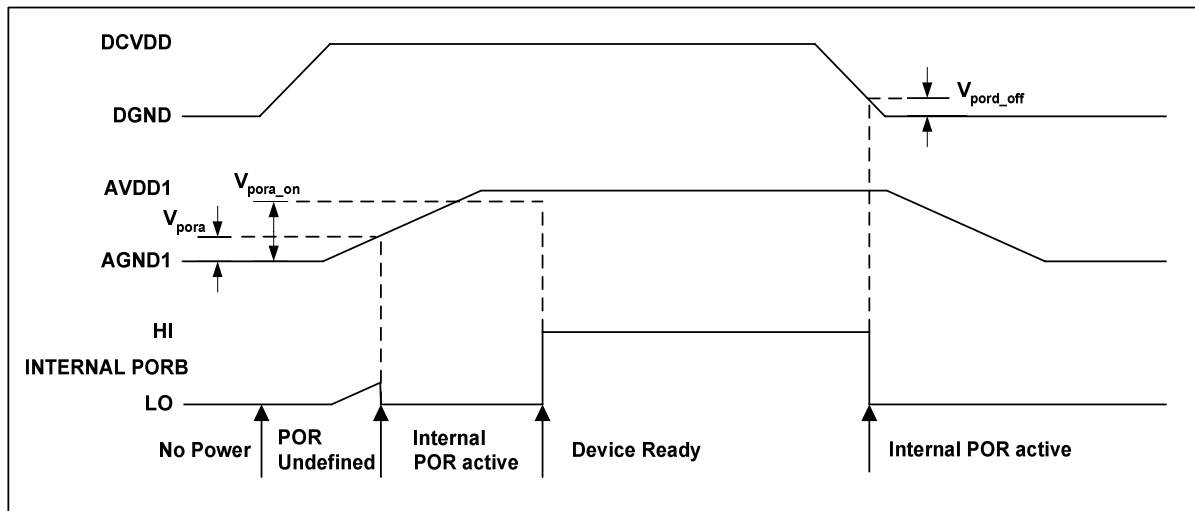

Figure 9 Typical Power up Sequence where DCVDD is Powered before AVDD1

Figure 9 shows a typical power-up sequence where DCVDD comes up first. First it is assumed that DCVDD is already up to specified operating voltage. When AVDD1 goes above the minimum threshold, V_{pora} , there is enough voltage for the circuit to guarantee PORB is asserted low and the chip is held in reset. In this condition, all writes to the control interface are ignored. When AVDD1 rises to V_{pora_on} , PORB is released high and all registers are in their default state and writes to the control interface may take place.

On power down, where DCVDD falls first, PORB is asserted low whenever DCVDD drops below the minimum threshold V_{pord_off} .

SYMBOL	MIN	TYP	MAX	UNIT
V_{pora}	0.4	0.6	0.8	V
V_{pora_on}	0.9	1.2	1.6	V
V_{pora_off}	0.4	0.6	0.8	V
V_{pord_on}	0.5	0.7	0.9	V
V_{pord_off}	0.4	0.6	0.8	V

Table 2 Typical POR Operation (Typical Simulated Values)

Notes:

1. If AVDD1 and DCVDD suffer a brown-out (i.e. drop below the minimum recommended operating level but do not go below V_{pora_off} or V_{pord_off}) then the chip will not reset and will resume normal operation when the voltage is back to the recommended level again.
2. The chip will enter reset at power down when AVDD1 or DCVDD falls below V_{pora_off} or V_{pord_off} . This may be important if the supply is turned on and off frequently by a power management system.
3. The minimum t_{por} period is maintained even if DCVDD and AVDD1 have zero rise time. This specification is guaranteed by design rather than test.

RECOMMENDED POWER UP/DOWN SEQUENCE

In order to minimise output pop and click noise, it is recommended that the WM8986 device is powered up and down under control using the following sequences:

Power Up:

1. Turn on external power supplies. Wait for supply voltage to settle.
2. Set low analogue bias mode, BIASCUT = 1
3. Enable thermal shutdown TSDEN = TSOPCTRL = 1
4. Enable Internal bias BIASEN = 1.
5. Mute all outputs and set PGAs to minimum gain, R52 to R57 = 0x140h.
6. Enable VMID independent current bias, POBCTRL = 1.
7. Enable required outputs, DACs and mixers.
8. Enable VMID with required charge time e.g. VMIDSEL=01.
9. Wait 500ms ¹
10. Setup digital interface, input amplifiers, PLL, and DACs for desired operation.
11. Disable VMID independent current bias, POBCTRL = 0.
12. Unmute L/ROUT1 and set desired volume, e.g. for 0dB R52 and R53 = 0x139h.
13. Unmute L/ROUT2 and set desired volume, e.g. for 0dB R54 and R55 = 0x139h.

Power Down ²:

1. Disable Thermal shutdown, TSDEN = TSOPCTRL = 0
2. Disable VMIDSEL=00 and BIASEN=0
3. Wait for VMID to discharge ³
4. Power off registers R1, R2, R3 = 0x000h
5. Remove external power supplies

Notes:

1. Charging time constant is determined by impedance selected by VMIDSEL and the value of decoupling capacitor connected to VMID pin.
2. It is possible to interrupt the power down sequence and power up to VMID before the allocated VMID discharge time. This is done by following the power-up sequence omitting steps 4 to 8.
3. Discharge time constant is determined by the values of analogue output capacitors.

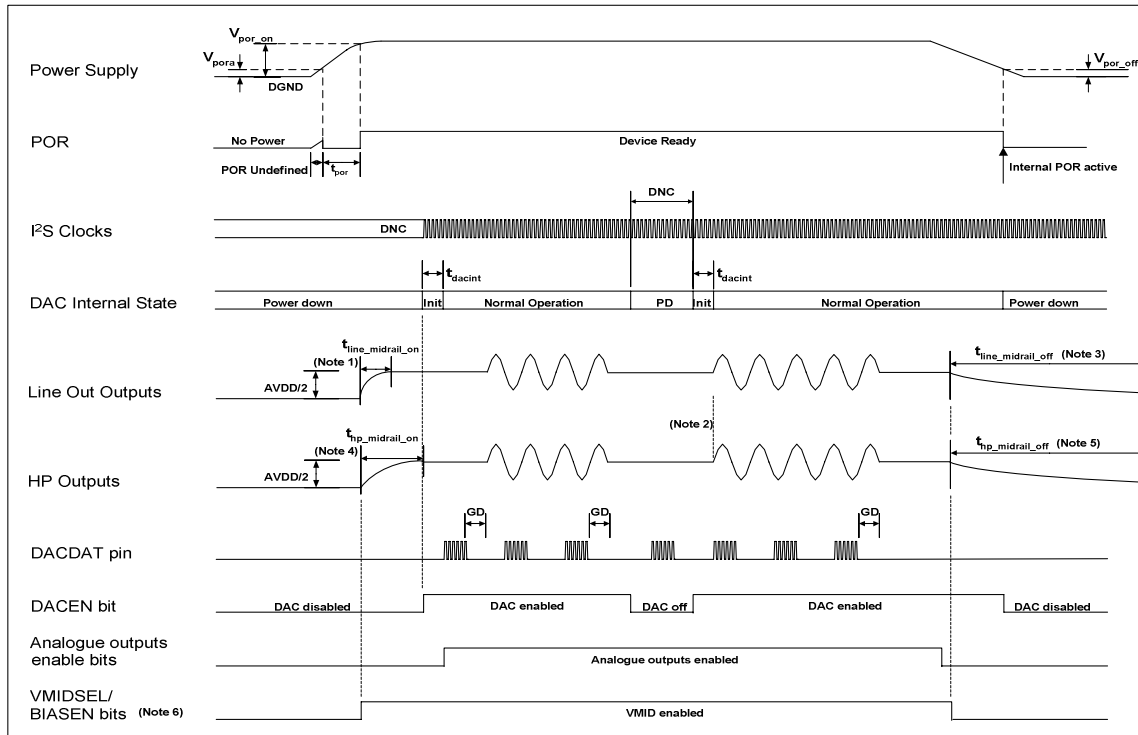

Figure 10 DAC Power Up and Down Sequence (not to scale)

SYMBOL	MIN	TYPICAL	MAX	UNIT
$t_{line_midrail_on}$		300		ms
$t_{line_midrail_off}$		>6		s
$t_{hp_midrail_on}$		300		ms
$t_{hp_midrail_off}$		>6		s
t_{dacint}		2/fs		n/fs
DAC Group Delay		51/fs		n/fs

Table 3 Typical POR Operation (Typical Simulated Values)

Notes:

1. The lineout charge time, $t_{line_midrail_on}$, is determined by the VMID pin charge time. This time is dependent upon the value of VMID decoupling capacitor and VMID pin input resistance and AVDD1 power supply rise time. The values above were measured using a 4.7µF capacitor.
2. It is not advisable to allow DACDAT data input during initialisation of the DAC. If the DAC data value is not zero at point of initialisation, then this is likely to cause a pop noise on the analogue outputs. The same is also true if the DACDAT is removed at a non-zero value, and no mute function has been applied to the signal beforehand.
3. The lineout discharge time, $t_{line_midrail_off}$, is determined by the VMID pin discharge time. This time is dependent upon the value of VMID decoupling capacitor and VMID pin input resistance. The values above were measured using a 4.7µF capacitor.
4. The headphone charge time, $t_{hp_midrail_on}$, is dependent upon the value of VMID decoupling capacitor and VMID pin input resistance and AVDD1 power supply rise time. The values above were measured using a 4.7µF VMID decoupling capacitor.
5. The headphone discharge time, $t_{hp_midrail_off}$, is dependent upon the value of VMID decoupling capacitor and VMID pin input resistance. The values above were measured using a 4.7µF VMID decoupling capacitor.
6. The VMIDSEL and BIASSEN bits must be set to enable analogue output midrail voltage and for normal DAC operation.

DEVICE DESCRIPTION

INTRODUCTION

The WM8986 is a low power audio IC combining a high quality stereo audio DAC with flexible line and microphone input and output processing.

FEATURES

The chip offers great flexibility in use, and so can support many different modes of operation as follows:

HI-FI DAC

The hi-fi DAC provides high quality audio playback suitable for all portable audio hi-fi type applications, including MP3 players and portable disc players of all types.

OUTPUT MIXERS

Flexible mixing is provided on the outputs of the device. A stereo mixer is provided for the stereo headphone or line outputs, LOUT1/ROUT1, and additional summers on the OUT3/OUT4 outputs allow for an optional differential or stereo line output on these pins. Gain adjustment PGAs are provided for the LOUT1/ROUT1 and LOUT2/ROUT2 outputs, and signal switching is provided to allow for all possible signal combinations.

OUT3 and OUT4 can be configured to provide an additional stereo or mono differential lineout from the output of the DACs, the mixers or the input microphone boost stages. They can also provide a midrail reference for pseudo differential inputs to external amplifiers. OUT3 and OUT4 should not be used as a buffered midrail reference in capless mode.

LINE INPUTS (AUXL, AUXR)

The inputs, AUXL and AUXR, can be used as a stereo line input (e.g. melody chip or FM radio) or as an input for warning tones (or 'beeps') etc. These inputs can be summed into the output paths, along with the microphone preamp outputs.

MICROPHONE INPUTS

Two pairs of stereo microphone inputs are provided, allowing a pair of stereo microphones to be pseudo-differentially connected, with user defined gain. The provision of the common mode input pin for each stereo input allows for rejection of common mode noise on the microphone inputs (level depends on gain setting chosen).

Total gain through the microphone paths of up to +55.25dB can be selected.

AUDIO INTERFACES

The WM8986 has a standard audio interface, to support the transmission of stereo data to and from the chip. This interface is a 3 wire standard audio interface which supports a number of audio data formats including:

- I²S
- DSP/PCM Mode (a burst mode in which LRC sync plus 2 data packed words are transmitted)
- MSB-First, left justified
- MSB-First, right justified

The interface can operate in master or slave modes.

CONTROL INTERFACES

To allow full software control over all features, the WM8986 offers a choice of 2 or 3 wire control interface. It is fully compatible and an ideal partner for a wide range of industry standard microprocessors, controllers and DSPs.

Selection of the mode is via the MODE pin. In 2 wire mode, the address of the device is fixed as 0011010.

CLOCKING SCHEMES

WM8986 offers the normal audio DAC clocking scheme operation, where 256fs MCLK is provided to the DAC. A flexible clock divider allows the 256fs DAC clock to be generated from a range of input clock frequencies, for example, 256fs, 384fs, 512fs and 768fs.

A PLL is included which may be used to generate these clocks in the event that they are not available from the system controller. This PLL can accept a range of common input clock frequencies between 8MHz and 50MHz to generate high quality audio clocks. If this PLL is not required for generation of these clocks, it can be reconfigured to generate alternative clocks which may then be output on the GPIO1 pin and used elsewhere in the system; available in 2-wire control mode only.

POWER CONTROL

The design of the WM8986 has given much attention to power consumption without compromising performance. The WM8986 operates at low analog and digital supply voltages, and includes the ability to power off any unused parts of the circuitry under software control. It also includes standby and power off modes.

INPUT SIGNAL PATH

The WM8986 has a number of flexible analogue inputs. There are two input channels, Left and Right, each of which consists of an input PGA stage followed by a boost/mix stage which drives into the output mixers. Each input path has three input pins which can be configured in a variety of ways to accommodate single-ended, pseudo-differential or dual differential microphones. There are two auxiliary input pins which can be fed into to the input boost/mix stage as well as driving into the output path. An additional signal path exists from the output of the boost/mix stage into the output left/right mixers.

MICROPHONE INPUTS

The WM8986 can accommodate a variety of microphone configurations including single ended and pseudo-differential inputs. The inputs to the left differential input PGA are LIN and LIP. The inputs to the right differential input PGA are RIN and RIP.

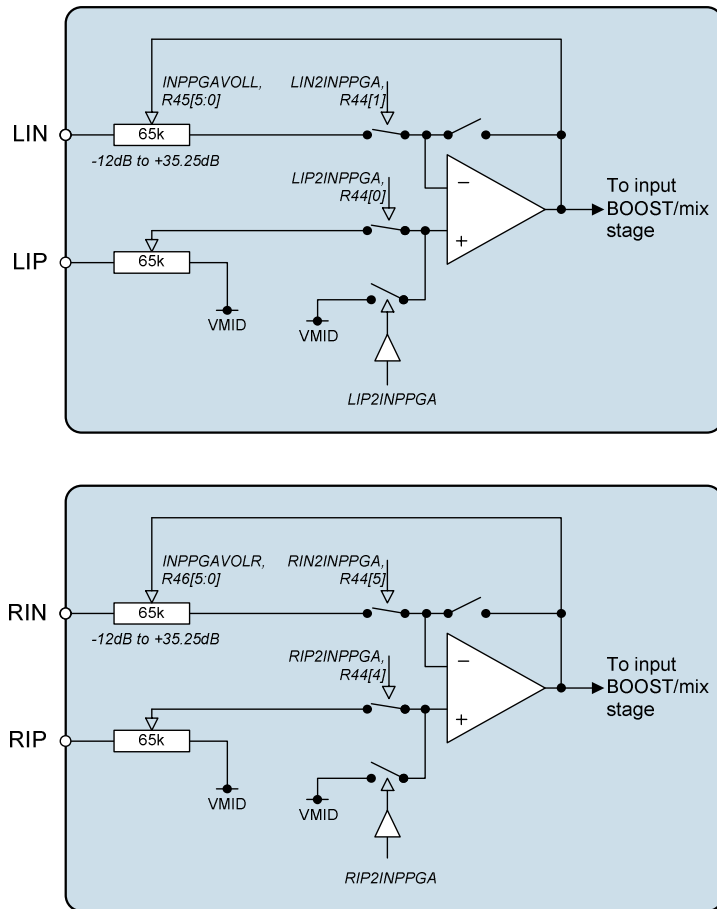

Figure 11 Microphone Input PGA Circuit

In single-ended microphone input configuration the microphone signal should be input to LIN or RIN and the non-inverting input of the input PGA clamped to VMID.

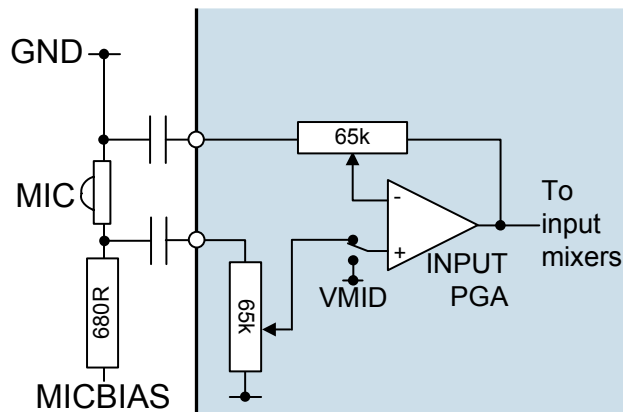

Figure 12 Psuedo-Differential Microphone Configuration

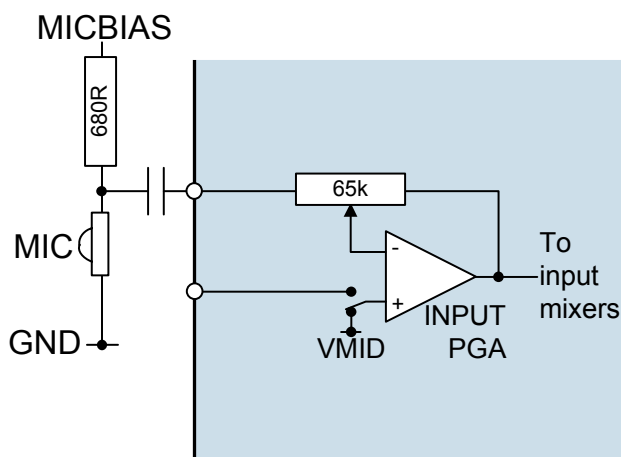

Figure 13 Single-ended Microphone Configuration

The input PGAs are enabled by the INPPGAENL and INPPGAENR register bits.

REGISTER ADDRESS	BIT	LABEL	DEFAULT	DESCRIPTION
R2 (02h) Power Management 2	2	INPPGAENL	0	Left channel input PGA enable 0 = disabled 1 = enabled
	3	INPPGAENR	0	Right channel input PGA enable 0 = disabled 1 = enabled

Table 4 Input PGA Enable Register Settings

REGISTER ADDRESS	BIT	LABEL	DEFAULT	DESCRIPTION
R44 (2Ch) Input Control	1	LIN2INPPGA	1	Connect LIN pin to left channel input PGA negative terminal. 0 = LIN not connected to input PGA 1 = LIN connected to input PGA amplifier negative terminal.
	5	RIN2INPPGA	1	Connect RIN pin to right channel input PGA negative terminal. 0 = RIN not connected to input PGA 1 = RIN connected to right channel input PGA amplifier negative terminal.

Table 5 Input PGA Control

INPUT PGA VOLUME CONTROLS

The input microphone PGAs have a gain range from -12dB to +35.25dB in 0.75dB steps. The gain from the LIN/RIN input to the PGA output is controlled by the register bits INPPGAVOLL[5:0] and INPPGAVOLR[5:0]. These register bits also affect the LIP pin when LIP2INPPGA=1 and the RIP pin when RIP2INPPGA=1.

REGISTER ADDRESS	BIT	LABEL	DEFAULT	DESCRIPTION
R45 (20h) Left channel input PGA volume control	5:0	INPPGAVOLL	010000 (0dB)	Left channel input PGA volume 000000 = -12dB 000001 = -11.25db . 010000 = 0dB . 111111 = +35.25dB
	6	INPPGAMUTEL	0	Mute control for left channel input PGA: 0 = Input PGA not muted, normal operation 1 = Input PGA muted (and disconnected from the following input BOOST stage).
	7	INPPGAZCL	0	Left channel input PGA zero cross enable: 0 = Update gain when gain register changes 1 = Update gain on 1 st zero cross after gain register write.
	8	INPPGAVU	Not latched	INPPGA left and INPPGA right volume do not update until a 1 is written to INPPGAVU (in reg 45 or 46) (See "Volume Updates" below)
R46 (2Eh) Right channel input PGA volume control	5:0	INPPGAVOLR	010000 (0dB)	Right channel input PGA volume 000000 = -12dB 000001 = -11.25db . 010000 = 0dB . 111111 = +35.25dB
	6	INPPGAMUTER	0	Mute control for right channel input PGA: 0 = Input PGA not muted, normal operation 1 = Input PGA muted (and disconnected from the following input BOOST stage).
	7	INPPGAZCR	0	Right channel input PGA zero cross enable: 0 = Update gain when gain register changes 1 = Update gain on 1 st zero cross after gain register write.
	8	INPPGAVU	Not latched	INPPGA left and INPPGA right volume do not update until a 1 is written to INPPGAVU (in reg 45 or 46) (See "Volume Updates" below)

Table 6 Input PGA Volume Control

VOLUME UPDATES

Volume settings will not be applied to the PGAs until a '1' is written to one of the INPPGAVU bits. This is to allow left and right channels to be updated at the same time, as shown in Figure 14.

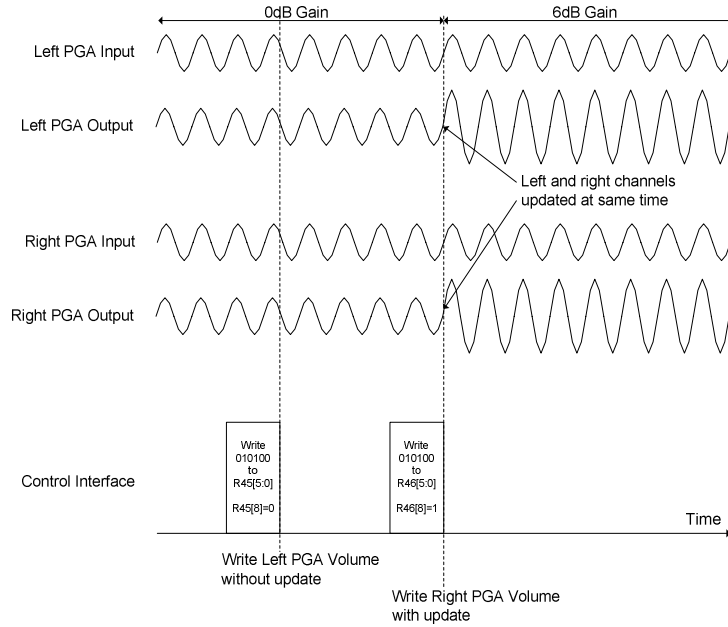

Figure 14 Simultaneous Left and Right Volume Updates

If the volume is adjusted while the signal is a non-zero value, an audible click can occur as shown in Figure 15.

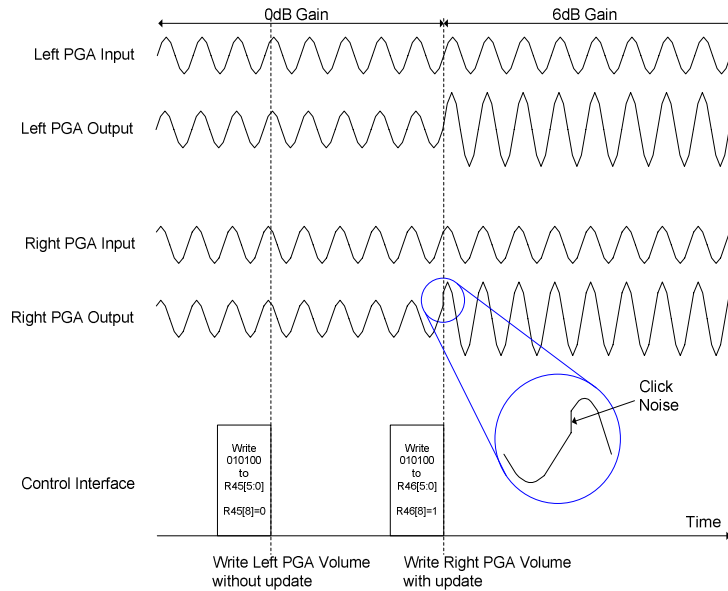

Figure 15 Click Noise During Volume Update

In order to prevent this click noise, a zero cross function is provided. When enabled, this will cause the PGA volume to update only when a zero crossing occurs, minimising click noise as shown in Figure 16.

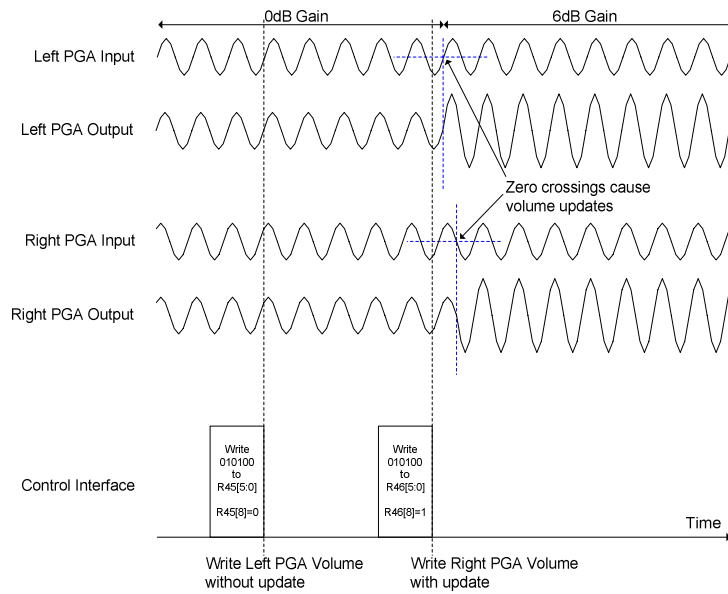

Figure 16 Volume Update Using Zero Cross Detection

If there is a long period where no zero-crossing occurs, a timeout circuit in the WM8986 will automatically update the volume. The volume updates will occur between one and two timeout periods, depending on when the INPPGAVU bit is set as shown in Figure 17.

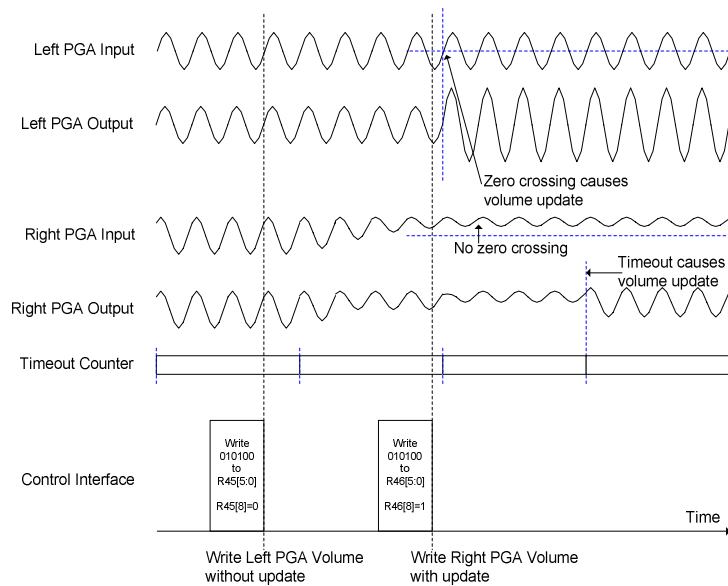

Figure 17 Volume Update After Timeout

AUXILIARY INPUTS

There are two auxiliary inputs, AUXL and AUXR which can be used for a variety of purposes such as stereo line inputs or as a 'beep' input signal to be mixed with the outputs.

The AUXL/R inputs can be used as a line input to the input BOOST stage which has adjustable gain of -12dB to +6dB in 3dB steps, with an additional "off" state (i.e. not connected). See the INPUT BOOST section for further details.

The AUXL/R inputs can also be mixed into the output channel mixers, with a gain of -15dB to +6dB plus off.

INPUT BOOST

Each of the stereo input PGA stages is followed by an input BOOST circuit. The input BOOST circuit has 2 selectable inputs: the input microphone PGA output or the AUX amplifier output. These three inputs can be mixed together and have individual gain boost/adjust as shown in Figure 18.

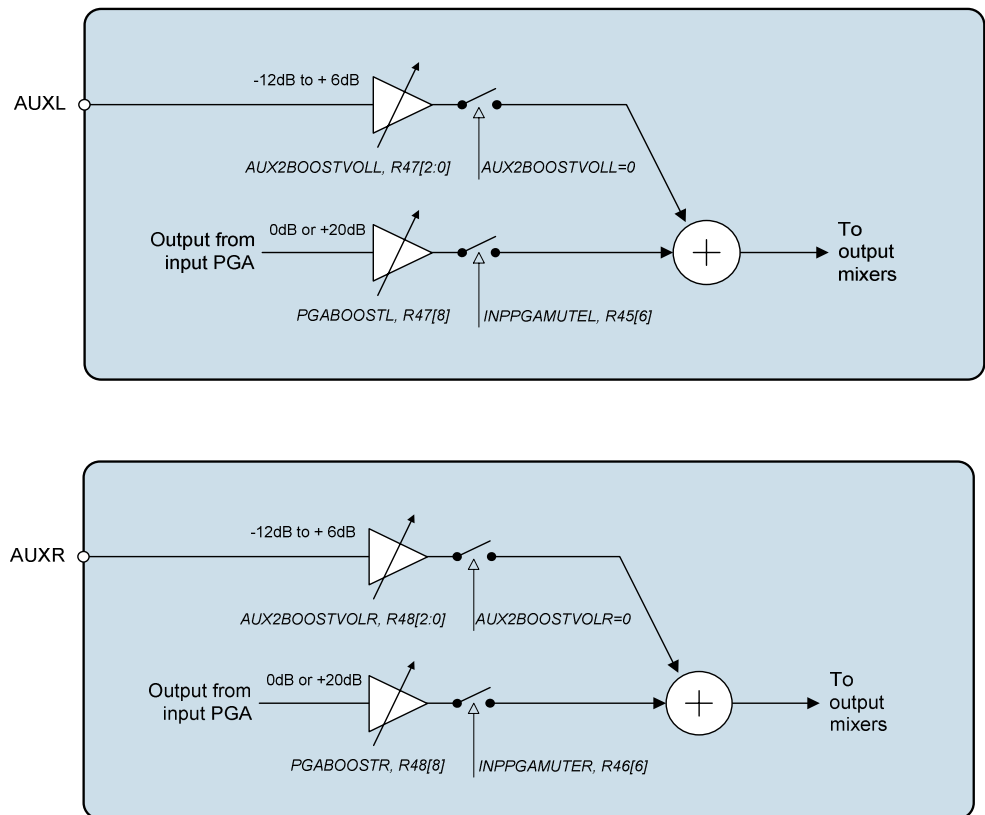

Figure 18 Input Boost Stage

The input PGA paths can have a +20dB boost (PGABOOSTL/R=1), a 0dB pass through (PGABOOSTL/R=0) or be completely isolated from the input boost circuit (INPPGAMUTEL/R=1).

REGISTER ADDRESS	BIT	LABEL	DEFAULT	DESCRIPTION
R47 (2Fh) Left Input BOOST control	8	PGABOOSTL	1	Boost enable for left channel input PGA: 0 = PGA output has +0dB gain through input BOOST stage. 1 = PGA output has +20dB gain through input BOOST stage.
R48 (30h) Right Input BOOST control	8	PGABOOSTR	1	Boost enable for right channel input PGA: 0 = PGA output has +0dB gain through input BOOST stage. 1 = PGA output has +20dB gain through input BOOST stage.

Table 7 Input BOOST Stage Control

The Auxiliary amplifier path to the BOOST stages is controlled by the AUXL2BOOSTVOL[2:0] and AUXR2BOOSTVOL[2:0] register bits. When AUXL2BOOSTVOL/AUXR2BOOSTVOL=000 this path is completely disconnected from the BOOST stage. Settings 001 through to 111 control the gain in 3dB steps from -12dB to +6dB.

REGISTER ADDRESS	BIT	LABEL	DEFAULT	DESCRIPTION
R47 (2Fh) Left channel Input BOOST control	2:0	AUXL2BOOSTVOL	000	Controls the auxiliary amplifier to the left channel input boost stage: 000 = Path disabled (disconnected) 001 = -12dB gain 010 = -9dB gain 011 = -6dB gain 100 = -3dB gain 101 = +0dB gain 110 = +3dB gain 111 = +6dB gain
R48 (30h) Right channel Input BOOST control	2:0	AUXR2BOOSTVOL	000	Controls the auxiliary amplifier to the right channel input boost stage: 000 = Path disabled (disconnected) 001 = -12dB gain 010 = -9dB gain 011 = -6dB gain 100 = -3dB gain 101 = +0dB gain 110 = +3dB gain 111 = +6dB gain

Table 8 Input BOOST Stage Control

The BOOST stage is enabled under control of the BOOSTEN register bit.

REGISTER ADDRESS	BIT	LABEL	DEFAULT	DESCRIPTION
R2 (02h) Power management 2	4	BOOSTENL	0	Left channel Input BOOST enable 0 = Boost stage OFF 1 = Boost stage ON
	5	BOOSTENR	0	Right channel Input BOOST enable 0 = Boost stage OFF 1 = Boost stage ON

Table 9 Input BOOST Enable Control

OUTPUT SIGNAL PATH

The WM8986 output signal paths consist of digital application filters, up-sampling filters, stereo Hi-Fi DACs, analogue mixers, stereo headphone and stereo line/mono/midrail output drivers. The digital filters and DAC are enabled by register bits DACENL and DACENR. The mixers and output drivers can be separately enabled by individual control bits (see Analogue Outputs). Thus it is possible to utilise the analogue mixing and amplification provided by the WM8986, irrespective of whether the DACs are running or not.

The WM8986 DACs receive digital input data on the DACDAT pin. The digital filter block processes the data to provide the following functions:

- Digital volume control
- Graphic equaliser and 3-D enhancement
- A digital peak limiter.
- Sigma-Delta Modulation

High performance sigma-delta audio DAC converts the digital data into an analogue signal.

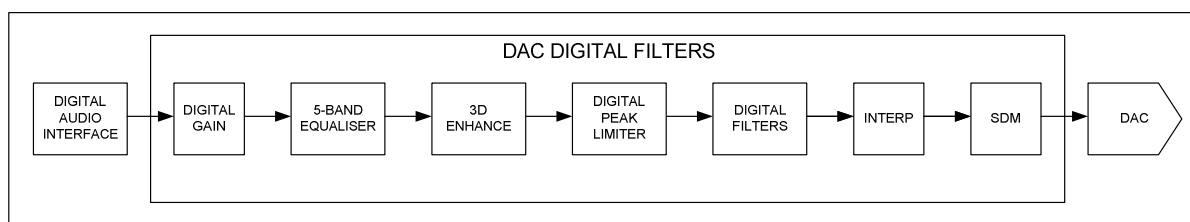

Figure 19 DAC Digital Filter Path

The analogue outputs from the DACs can then be mixed with the various analogue inputs. The mix is fed to the output drivers for headphone (LOUT1/ROUT1, LOU22/ROUT2) or line (OUT3/OUT4). OUT3 and OUT4 have additional mixers which allow them to output different signals to the line outputs.

DIGITAL PLAYBACK (DAC) PATH

Digital data is passed to the WM8986 via the flexible audio interface and is then passed through a variety of advanced digital filters as shown in Figure 19 to the hi-fi DACs. The DACs are enabled by the DACENL/R register bits.

REGISTER ADDRESS	BIT	LABEL	DEFAULT	DESCRIPTION
R3 (03h) Power Management 3	0	DACENL	0	Left channel DAC enable 0 = DAC disabled 1 = DAC enabled
	1	DACENR	0	Right channel DAC enable 0 = DAC disabled 1 = DAC enabled

Table 10 DAC Enable Control

The WM8986 also has a Soft Mute function, which when enabled, gradually attenuates the volume of the digital signal to zero. When disabled, the gain will ramp back up to the digital gain setting. This function is enabled by default. To play back an audio signal, it must first be disabled by setting the SOFTMUTE bit to zero.

REGISTER ADDRESS	BIT	LABEL	DEFAULT	DESCRIPTION
R10 (0Ah) DAC Control	0	DACPOL	0	Left DAC output polarity: 0 = non-inverted 1 = inverted (180 degrees phase shift)
	1	DACRPOL	0	Right DAC output polarity: 0 = non-inverted 1 = inverted (180 degrees phase shift)
	2	AMUTE	0	Automute enable 0 = Amute disabled 1 = Amute enabled
	3	DACOSR128	0	DAC oversampling rate: 0 = 64x (lowest power) 1 = 128x (best performance)
	6	SOFTMUTE	0	Softmute enable: 0 = Enabled 1 = Disabled

Table 11 DAC Control Register

The digital audio data is converted to oversampled bit streams in the on-chip, true 24-bit digital interpolation filters. The bitstream data enters the multi-bit, sigma-delta DACs, which convert it to a high quality analogue audio signal. The multi-bit DAC architecture reduces high frequency noise and sensitivity to clock jitter. It also uses a Dynamic Element Matching technique for high linearity and low distortion.

The DAC output phase defaults to non-inverted. Setting DACLPOL will invert the DAC output phase on the left channel and DACRPOL inverts the phase on the right channel.

AUTO-MUTE

The DAC has an auto-mute function which applies an analogue mute when 1024 consecutive zeros are detected. The mute is released as soon as a non-zero sample is detected. Auto-mute can be disabled using the AMUTE control bit.

DIGITAL HI-FI DAC VOLUME (GAIN) CONTROL

The signal volume from each Hi-Fi DAC can be controlled digitally. The gain range is -127dB to 0dB in 0.5dB steps. The level of attenuation for an eight-bit code X is given by:

$$0.5 \times (X-255) \text{ dB for } 1 \leq X \leq 255; \quad \text{MUTE for } X = 0$$

REGISTER ADDRESS	BIT	LABEL	DEFAULT	DESCRIPTION
R11 (0Bh) Left DAC Digital Volume	7:0	DACL VOL [7:0]	11111111 (0dB)	Left DAC Digital Volume Control 0000 0000 = Digital Mute 0000 0001 = -127dB 0000 0010 = -126.5dB ... 0.5dB steps up to 1111 1111 = 0dB
	8	DACVU	Not latched	DAC left and DAC right volume do not update until a 1 is written to DACVU (in reg 11 or 12)
R12 (0Ch) Right DAC Digital Volume	7:0	DACR VOL [7:0]	11111111 (0dB)	Right DAC Digital Volume Control 0000 0000 = Digital Mute 0000 0001 = -127dB 0000 0010 = -126.5dB ... 0.5dB steps up to 1111 1111 = 0dB
	8	DACVU	Not latched	DAC left and DAC right volume do not update until a 1 is written to DACVU (in reg 11 or 12)

Table 12 DAC Digital Volume Control

Note: An additional gain of up to 12dB can be added using the gain block embedded in the digital peak limiter circuit (see DAC OUTPUT LIMITER section).

5-BAND EQUALISER

A 5-band graphic equaliser function which can be used to change the output frequency levels to suit the environment. This is described in the 5-BAND EQUALISER section.

3-D ENHANCEMENT

The WM8986 has an advanced digital 3-D enhancement feature which can be used to vary the perceived stereo separation of the left and right channels. Refer to the 3-D STEREO ENHANCEMENT section for further details on this feature.

DAC DIGITAL OUTPUT LIMITER

The WM8986 has a digital output limiter function. The operation of this is shown in Figure 20. In this diagram the upper graph shows the envelope of the input/output signals and the lower graph shows the gain characteristic.

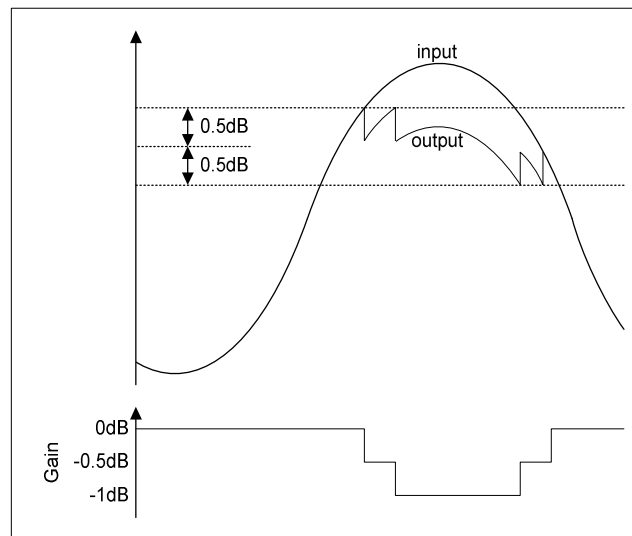

Figure 20 DAC Digital Limiter Operation

The limiter has a programmable upper threshold which is close to 0dB. Referring to Figure 20, in normal operation (LIMBOOST=000 => limit only) signals below this threshold are unaffected by the limiter. Signals above the upper threshold are attenuated at a specific attack rate (set by the LIMATK register bits) until the signal falls below the threshold. The limiter also has a lower threshold 1dB below the upper threshold. When the signal falls below the lower threshold the signal is amplified at a specific decay rate (controlled by LIMDCY register bits) until a gain of 0dB is reached. Both threshold levels are controlled by the LIMLVL register bits. The upper threshold is 0.5dB above the value programmed by LIMLVL and the lower threshold is 0.5dB below the LIMLVL value.

VOLUME BOOST

The limiter has programmable upper gain which boosts signals below the threshold to compress the dynamic range of the signal and increase its perceived loudness. This operates as an ALC function with limited boost capability. The volume boost is from 0dB to +12dB in 1dB steps, controlled by the LIMBOOST register bits.

The output limiter volume boost can also be used as a stand alone digital gain boost when the limiter is disabled.

REGISTER ADDRESS	BIT	LABEL	DEFAULT	DESCRIPTION
R24 (18h) DAC digital limiter control 1	3:0	LIMATK	0010	Limiter Attack time (per 6dB gain change) for 44.1kHz sampling. Note that these are proportionally related to sample rate. 0000 = 94us 0001 = 188s 0010 = 375us 0011 = 750us 0100 = 1.5ms 0101 = 3ms 0110 = 6ms 0111 = 12ms 1000 = 24ms 1001 = 48ms 1010 = 96ms 1011 to 1111 = 192ms
	7:4	LIMDCY	0011	Limiter Decay time (per 6dB gain change) for 44.1kHz sampling. Note that these are proportionally related to sample rate: 0000 = 750us 0001 = 1.5ms 0010 = 3ms 0011 = 6ms 0100 = 12ms 0101 = 24ms 0110 = 48ms 0111 = 96ms 1000 = 192ms 1001 = 384ms 1010 = 768ms 1011 to 1111 = 1.536s
	8	LIMEN	0	Enable the DAC digital limiter: 0=disabled 1=enabled
R25 (19h) DAC digital limiter control 2	3:0	LIMBOOST	0000	Limiter volume boost (can be used as a stand alone volume boost when LIMEN=0): 0000 = 0dB 0001 = +1dB 0010 = +2dB 0011 = +3dB 0100 = +4dB 0101 = +5dB 0110 = +6dB 0111 = +7dB 1000 = +8dB 1001 = +9dB 1010 = +10dB 1011 = +11dB 1100 = +12dB 1101 to 1111 = reserved

REGISTER ADDRESS	BIT	LABEL	DEFAULT	DESCRIPTION
	6:4	LIMLVL	000	Programmable signal threshold level (determines level at which the limiter starts to operate) 000 = -1dB 001 = -2dB 010 = -3dB 011 = -4dB 100 = -5dB 101 to 111 = -6dB

Table 13 DAC Digital Limiter Control

5-BAND GRAPHIC EQUALISER

A 5-band graphic equaliser is provided, which can be applied to the DAC path, together with 3D enhancement, under control of the EQ3DEN register bit.

REGISTER ADDRESS	BIT	LABEL	DEFAULT	DESCRIPTION
R18 (12h) EQ Control 1	8	EQ3DEN	1	0 = Equaliser and 3D Enhancement disabled 1 = Equaliser and 3D Enhancement enabled

Table 14 EQ and 3D Enhancement enable

Note: The DACs must be disabled before changing the EQ3DEN bit.

A 5-band graphic equaliser consists of low and high frequency shelving filters (Band 1 and 5) and three peak filters for the centre bands. Each has adjustable cut-off or centre frequency, and selectable boost (+/- 12dB in 1dB steps). The peak filters have selectable bandwidth.

To enable the use of the 5-band equaliser the device must be in 128fs mode by setting M128ENB to 1 in register R7 bit 8. Refer to the Low Power section under Power Management below for more details.

REGISTER ADDRESS	BIT	LABEL	DEFAULT	DESCRIPTION
R18 (12h) EQ Band 1 Control	4:0	EQ1G	01100 (0dB)	Band 1 Gain Control. See Table 20 for details.
	6:5	EQ1C	01	Band 1 Cut-off Frequency: 00 = 80Hz 01 = 105Hz 10 = 135Hz 11 = 175Hz

Table 15 EQ Band 1 Control

REGISTER ADDRESS	BIT	LABEL	DEFAULT	DESCRIPTION
R19 (13h) EQ Band 2 Control	4:0	EQ2G	01100 (0dB)	Band 2 Gain Control. See Table 20 for details.
	6:5	EQ2C	01	Band 2 Centre Frequency: 00 = 230Hz 01 = 300Hz 10 = 385Hz 11 = 500Hz
	8	EQ2BW	0	Band 2 Bandwidth Control 0 = narrow bandwidth 1 = wide bandwidth

Table 16 EQ Band 2 Control

REGISTER ADDRESS	BIT	LABEL	DEFAULT	DESCRIPTION
R20 (14h) EQ Band 3 Control	4:0	EQ3G	01100 (0dB)	Band 3 Gain Control. See Table 20 for details.
	6:5	EQ3C	01	Band 3 Centre Frequency: 00 = 650Hz 01 = 850Hz 10 = 1.1kHz 11 = 1.4kHz
	8	EQ3BW	0	Band 3 Bandwidth Control 0 = narrow bandwidth 1 = wide bandwidth

Table 17 EQ Band 3 Control

REGISTER ADDRESS	BIT	LABEL	DEFAULT	DESCRIPTION
R21 (15h) EQ Band 4 Control	4:0	EQ4G	01100 (0dB)	Band 4 Gain Control. See Table 20 for details
	6:5	EQ4C	01	Band 4 Centre Frequency: 00 = 1.8kHz 01 = 2.4kHz 10 = 3.2kHz 11 = 4.1kHz
	8	EQ4BW	0	Band 4 Bandwidth Control 0 = narrow bandwidth 1 = wide bandwidth

Table 18 EQ Band 4 Control

REGISTER ADDRESS	BIT	LABEL	DEFAULT	DESCRIPTION
R22 (16h) EQ Band 5 Gain Control	4:0	EQ5G	01100 (0dB)	Band 5 Gain Control. See Table 20 for details.
	6:5	EQ5C	01	Band 5 Cut-off Frequency: 00 = 5.3kHz 01 = 6.9kHz 10 = 9kHz 11 = 11.7kHz

Table 19 EQ Band 5 Control

GAIN REGISTER	GAIN
00000	+12dB
00001	+11dB
00010	+10dB
.... (1dB steps)	
01100	0dB
01101	-1dB
11000	-12dB
11001 to 11111	Reserved

Table 20 Gain Register Table

See also Figure 40 to Figure 53 for equaliser and high pass filter responses.

3D STEREO ENHANCEMENT

The WM8986 has a digital 3D enhancement option to increase the perceived separation between the left and right channels. The DEPTH3D setting controls the degree of stereo expansion.

REGISTER ADDRESS	BIT	LABEL	DEFAULT	DESCRIPTION
R41 (29h) 3D Control	3:0	DEPTH3D	0000	Stereo depth 0000 = Disabled 0001 = 6.67% 0010 = 13.3% 0011 = 20% 0100 = 26.7% 0101 = 33.3% 0110 = 40% 0111 = 46.6% 1000 = 53.3% 1001 = 60% 1010 = 66.7% 1011 = 73.3% 1100 = 80% 1101 = 86.7% 1110 = 93.3% 1111 = 100% (maximum 3D effect)

Table 21 3D Stereo Enhancement Function

Note: When 3D enhancement is used, it may be necessary to attenuate the signal by 6dB to avoid limiting.

ANALOGUE OUTPUTS

The WM8986 has three sets of stereo analogue outputs. These are:

- LOUT1 and ROUT1 which are normally used to drive a headphone load.
- LOUT2 and ROUT2 – which can be used as class D or class AB headphone drivers.
- OUT3 and OUT4 – can be configured as a stereo line out (OUT3 is left output and OUT4 is right output) or a differential output. OUT4 can also be used to provide a mono mix of left and right channels.

The outputs LOUT2 and ROUT2 are powered from AVDD2 and are capable of driving a 1V rms signal (AVDD1/3.3).

LOUT1, ROUT1, OUT3 and OUT4 are powered from AVDD1

LOUT1, ROUT1, LOUT2 and ROUT2 have individual analogue volume PGAs with -57dB to +6dB gain ranges.

There are four output mixers in the output signal path, the left and right channel mixers which control the signals to headphone (and optionally the line outputs) and also dedicated OUT3 and OUT4 mixers.

LEFT AND RIGHT OUTPUT CHANNEL MIXERS

The left and right output channel mixers are shown in Figure 21. These mixers allow the analogue inputs and the DAC left and right channels to be combined as desired. This allows a mono mix of the DAC channels to be performed as well as mixing in external line-in from the AUX or speech from the input PGAs.

The AUX and PGA path inputs have individual volume control from -15dB to +6dB and the DAC volume can be adjusted in the digital domain if required. The output of these mixers is connected to both the headphone (LOUT1 and ROUT1) and class D headphone (LOUT2 and ROUT2) and can optionally be connected to the OUT3 and OUT4 mixers.

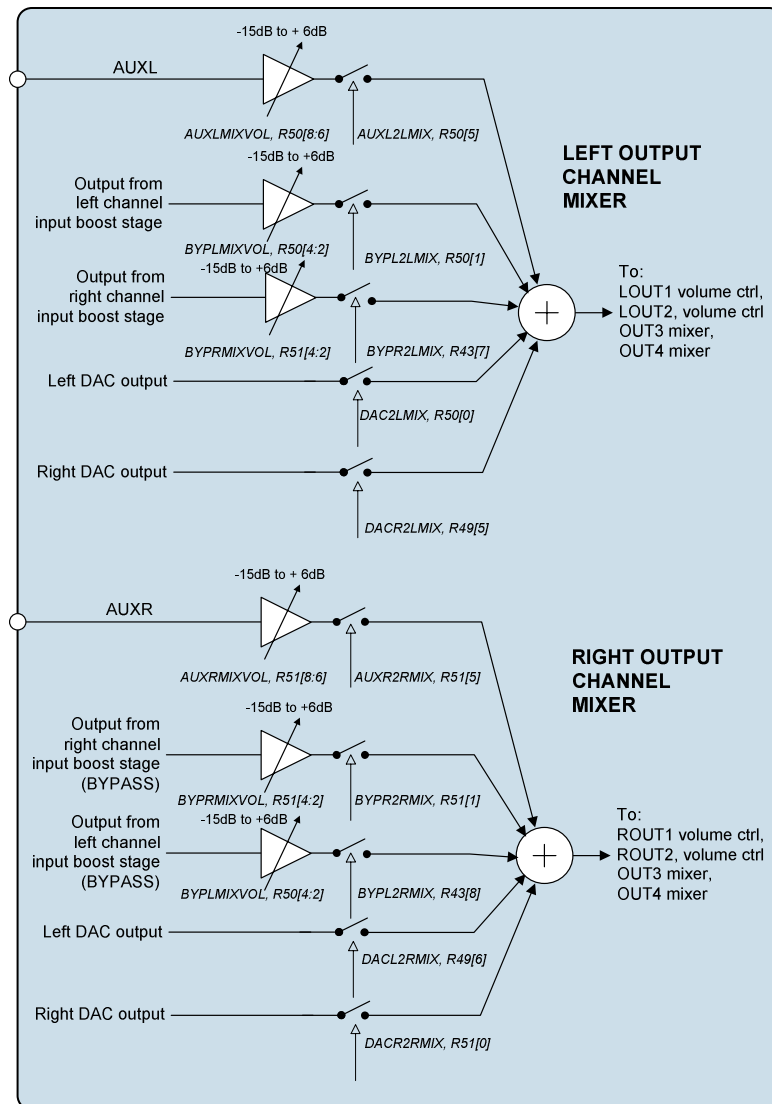

Figure 21 Left/Right Output Channel Mixers

REGISTER ADDRESS	BIT	LABEL	DEFAULT	DESCRIPTION
R43 (2Bh) Output mixer control	8	BYPL2RMIX	0	Left channel input PGA stage to right output mixer 0 = not selected 1 = selected
R43 (2Bh) Output mixer control	7	BYPR2LMIX	0	Right channel input PGA stage to Left output mixer 0 = not selected 1 = selected
R49 (31h) Output mixer control	5	DACR2LMIX	0	Right DAC output to left output mixer 0 = not selected 1 = selected
	6	DACL2RMIX	0	Left DAC output to right output mixer 0 = not selected 1 = selected
R50 (32h) Left channel output mixer control	0	DACL2LMIX	1	Left DAC output to left output mixer 0 = not selected 1 = selected
	1	BYPL2LMIX	0	Left channel input PGA stage to left output mixer 0 = not selected 1 = selected
	4:2	BYPLMIXVOL	000	Volume control for Left channel input PGA to left output channel mixer 000 = -15dB 001 = -12dB 010 = -9dB 011 = -6dB 100 = -3dB 101 = 0dB 110 = +3dB 111 = +6dB
	5	AUXL2LMIX	0	Left Auxiliary input to left channel output mixer: 0 = not selected 1 = selected
	8:6	AUXLMIXVOL	000	Aux left channel input to left mixer volume control: 000 = -15dB 001 = -12dB 010 = -9dB 011 = -6dB 100 = -3dB 101 = 0dB 110 = +3dB 111 = +6dB

REGISTER ADDRESS	BIT	LABEL	DEFAULT	DESCRIPTION
R51 (33h) Right channel output mixer control	0	DACR2RMIX	1	Right DAC output to right output mixer 0 = not selected 1 = selected
	1	BYPR2RMIX	0	Right channel input PGA stage to right output mixer 0 = not selected 1 = selected
	4:2	BYPRMIXVOL	000	Volume control for Right channel input PGA stage to right output mixer 000 = -15dB 001 = -12dB 010 = -9dB 011 = -6dB 100 = -3dB 101 = 0dB 110 = +3dB 111 = +6dB
	5	AUXR2RMIX	0	Right Auxiliary input to right channel output mixer: 0 = not selected 1 = selected
	8:6	AUXRMIXVOL	000	Aux right channel input to right mixer volume control: 000 = -15dB 001 = -12dB 010 = -9dB 011 = -6dB 100 = -3dB 101 = 0dB 110 = +3dB 111 = +6dB
R3 (03h) Power management 3	2	LMIXEN	0	Left output channel mixer enable: 0 = disabled 1 = enabled
	3	RMIXEN	0	Right output channel mixer enable: 0 = disabled 1 = enabled

Table 22 Left and Right Output Mixer Control

HEADPHONE OUTPUTS (LOUT1 AND ROUT1)

The headphone outputs LOUT1 and ROUT1 can drive a 16Ω or 32Ω headphone load, either through DC blocking capacitors, or DC-coupled to a buffered midrail reference (LOUT2 or ROUT2), saving a capacitor (capless mode). When using capless mode AVDD1 and AVDD2 should use the same supply to maximise supply rejection. OUT3 and OUT4 should not be used as a buffered midrail reference in capless mode.

Headphone Output using DC Blocking Capacitors

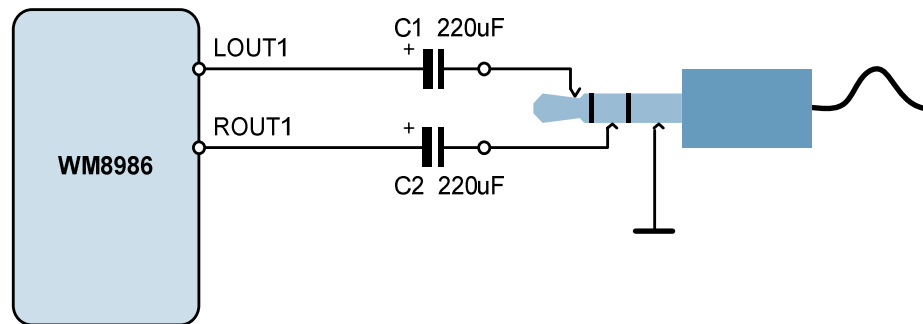

DC Coupled Headphone Output

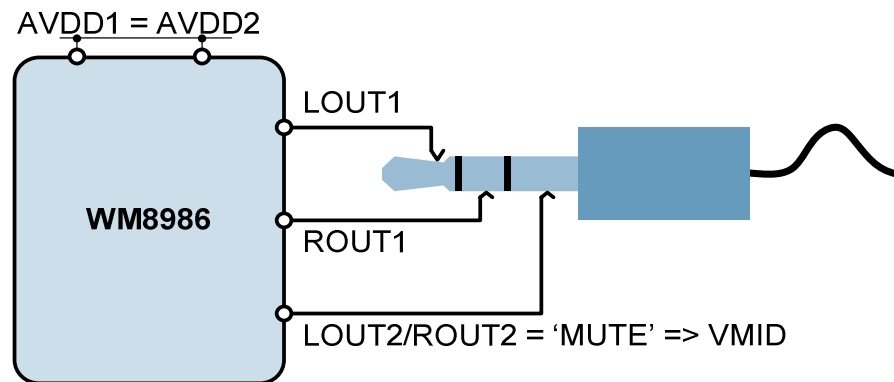

Figure 22 Recommended Headphone Output Configurations

When DC blocking capacitors are used, their capacitance and the load resistance together determine the lower cut-off frequency of the output signal, f_c . Increasing the capacitance lowers f_c , improving the bass response. Smaller capacitance values will diminish the bass response. Assuming a 16Ω load and $C_1, C_2 = 220\mu\text{F}$:

$$f_c = 1 / 2\pi R_L C_1 = 1 / (2\pi \times 16\Omega \times 220\mu\text{F}) = 45 \text{ Hz}$$

In the DC coupled configuration, the headphone pseudo-ground is connected to the buffered midrail reference pin (LOUT2 or ROUT2). The L/ROUT2 pins can be configured as a DC output driver by setting the LOUT2MUTE and ROUT2MUTE register bits. The DC voltage on VMID in this configuration is equal to the DC offset on the LOUT1 and ROUT1 pins therefore no DC blocking capacitors are required. This saves space and material cost in portable applications.

It is not recommended to use DC-coupling to line inputs of another device. Although the built-in short circuit protection on the headphone outputs would be tolerant of shorts to ground, such a connection could be noisy, and may not function properly if the other device is grounded. DC-coupled configurations should only be used with headphones.

REGISTER ADDRESS	BIT	LABEL	DEFAULT	DESCRIPTION
R52 (34h) LOUT1 Volume control	5:0	LOUT1VOL	111001 (0dB)	Left headphone output volume: (1dB steps) 000000 = -57dB ... 111001 = 0dB ... 111111 = +6dB
	6	LOUT1MUTE	0	Left headphone output mute: 0 = Normal operation 1 = Mute
	7	LOUT1ZC	0	Headphone volume zero cross enable: 1 = Change gain on zero cross only 0 = Change gain immediately
	8	HPVU	Not latched	LOUT1 and ROUT1 volumes do not update until a 1 is written to HPVU (in reg 52 or 53)
R53 ROUT1 Volume control	5:0	ROUT1VOL	111001 (0dB)	Right headphone output volume: (1dB steps) 000000 = -57dB ... 111001 = 0dB ... 111111 = +6dB
	6	ROUT1MUTE	0	Right headphone output mute: 0 = Normal operation 1 = Mute
	7	ROUT1ZC	0	Headphone volume zero cross enable: 1 = Change gain on zero cross only 0 = Change gain immediately
	8	HPVU	Not latched	LOUT1 and ROUT1 volumes do not update until a 1 is written to HPVU (in reg 52 or 53)

Table 23 OUT1 Volume Control

CLASS D / CLASS AB HEADPHONE OUTPUTS (LOUT2 AND ROUT2)

The outputs LOUT2 and ROUT2 are designed to drive two headphone loads of 16Ω or 32Ω or line outputs (See Headphone Output and Line Output sections, respectively). Each output has an individual volume control PGA, a mute and an enable control bit as shown in Figure 23. LOUT2 and ROUT2 output the left and right channel mixer outputs respectively.

REGISTER ADDRESS	BIT	LABEL	DEFAULT	DESCRIPTION
R7 (07h)	7:4	DCLKDIV	1000	Controls clock division from SYSCLK to generate suitable class D clock. Recommended class D clock frequency = 1.4MHz. 0000 = divide by 1 0010 = divide by 2 0011 = divide by 3 0100 = divide by 4 0101 = divide by 5.5 0110 = divide by 6 1000 = divide by 8 1001 = divide by 12 1010 = divide by 16
R23 (17h)	8	CLASSDEN	0	Enable signal for class D mode on LOUT2 and ROUT2 0 = Class AB mode 1 = Class D mode

Table 24 Class D Control Registers

When driving headphones using class D outputs it is necessary to use appropriate filtering, placed close to the device, to minimise EMI emissions from the headphone cable (Refer to "Applications Information" for more information). This filtering does not prevent class AB mode operation.

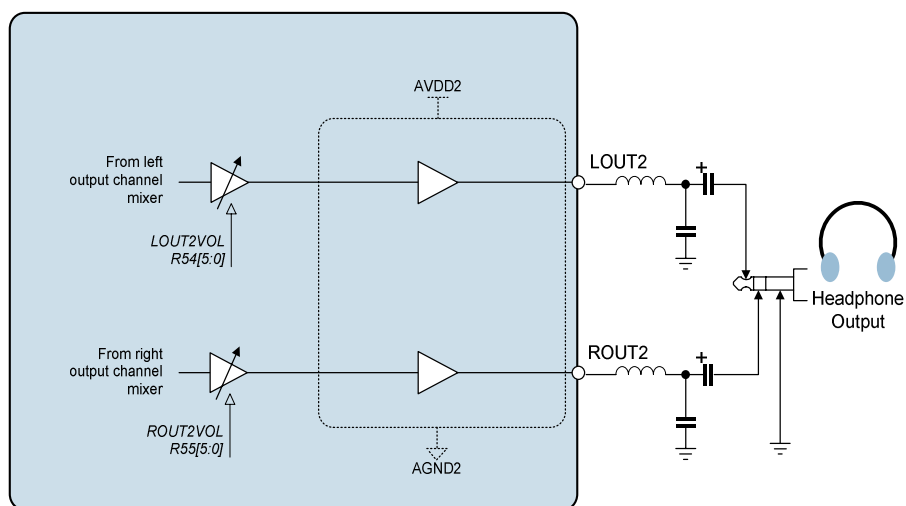

Figure 23 LOUT2 and ROUT2 Class D Headphone Configuration

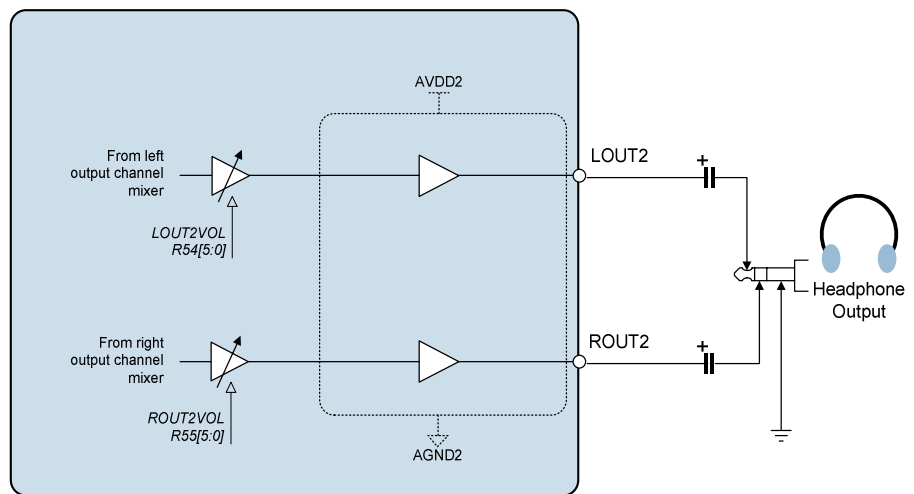

Figure 24 LOUT2 and ROUT2 Class AB Headphone Configuration

The output configurations shown in Figure 23 and Figure 24 are both suitable for class AB operation. The signal output on LOUT2/ROUT2 comes from the Left/Right Mixer circuits and can be any combination of the DAC output, the output of the input PGA stage, and the AUXL/R inputs. The LOUT2/ROUT2 volume is controlled by the LOUT2VOL/ ROUT2VOL register bits. Gains over 0dB may cause clipping if the input signal is too high. The LOUT2MUTE/ ROUT2MUTE register bits cause these outputs to be muted (the output DC level is driven out). The output pins remain at the same DC level, so that no click noise is produced when muting or un-muting.

REGISTER ADDRESS	BIT	LABEL	DEFAULT	DESCRIPTION
R54 (36h) LOUT2 Volume control	5:0	LOUT2VOL	111001	Left output volume: (1dB steps) 000000 = -57dB ... 111001 = 0dB ... 111111 = +6dB
	6	LOUT2MUTE	0	Left output mute: 0 = Normal operation 1 = Mute
	7	LOUT2ZC	0	LOUT2 volume zero cross enable: 1 = Change gain on zero cross only 0 = Change gain immediately
	8	OUT2VU	Not latched	LOUT2 and ROUT2 volumes do not update until a 1 is written to OUT2VU (in reg 54 or 55)
R55 (37h) ROUT2 Volume control	5:0	ROUT2VOL	111001	Right output volume: (1dB steps) 000000 = -57dB ... 111001 = 0dB ... 111111 = +6dB
	6	ROUT2MUTE	0	Right output mute: 0 = Normal operation 1 = Mute
	7	ROUT2ZC	0	ROUT2 volume zero cross enable: 1 = Change gain on zero cross only 0 = Change gain immediately
	8	OUT2VU	Not latched	LOUT2 and ROUT2 volumes do not update until a 1 is written to OUT2VU (in reg 54 or 55)

Table 25 OUT2 Volume Control

ZERO CROSS TIMEOUT

A zero-cross timeout function is provided so that if zero cross is enabled on the input or output PGAs the gain will automatically update after a timeout period if a zero cross has not occurred. This is enabled by setting SLOWCLKEN. The timeout period is dependent on the clock input to the digital and is equal to $2^{21} * \text{SYSCLK period}$.

REGISTER ADDRESS	BIT	LABEL	DEFAULT	DESCRIPTION
R7 (07h) Additional Control	0	SLOWCLKEN	0	Slow clock enable. 0 = slow clock disabled 1 = slow clock enabled

Table 26 Timeout Clock Enable Control

Note: SLOWCLKEN is also used for the jack insert detect debounce circuit

OUT3/OUT4 MIXERS AND OUTPUT STAGES

The OUT3/OUT4 pins provide an additional stereo line output, a mono output, or a differential output. There is a dedicated analogue mixer for OUT3 and one for OUT4 as shown in Figure 25.

The OUT3 and OUT4 output stages are powered from AVDD1 and AGND1.

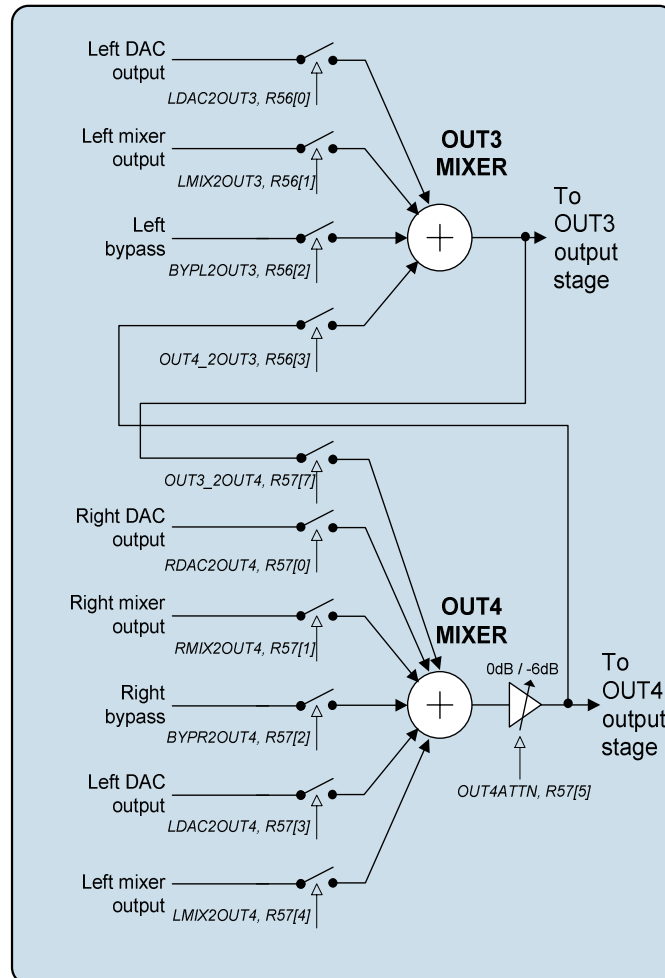

Figure 25 OUT3 and OUT4 Mixers

OUT3 can provide a left line output, or a mono mix line output.

OUT4 can provide a right line output, or a mono mix line output.

A 6dB attenuation function is provided for OUT4, to prevent clipping during mixing of left and right signals. This function is enabled by the OUT4ATTN register bit.

REGISTER ADDRESS	BIT	LABEL	DEFAULT	DESCRIPTION
R56 (38h) OUT3 mixer control	6	OUT3MUTE	0	0 = Output stage outputs OUT3 mixer 1 = Output stage muted – drives out VMID. Can be used as VMID reference in this mode. (Not to be used for Capless HP pseudo GND)
	3	OUT4_2OUT3	0	OUT4 mixer output to OUT3 0 = disabled 1 = enabled
	2	BYPL2OUT3	0	Left PGA output to OUT3 0 = disabled 1 = enabled
	1	LMIX2OUT3	0	Left DAC mixer to OUT3 0 = disabled 1 = enabled
	0	LDAC2OUT3	1	Left DAC output to OUT3 0 = disabled 1 = enabled
R57 (39h) OUT4 mixer control	7	OUT3_2OUT4	0	OUT3 mixer output to OUT4 0 = disabled 1 = enabled
	6	OUT4MUTE	0	0 = Output stage outputs OUT4 mixer 1 = Output stage muted – drives out VMID. Can be used as VMID reference in this mode. (Not to be used for Capless HP pseudo GND)
	5	OUT4ATTN	0	0 = OUT4 normal output 1 = OUT4 attenuated by 6dB
	4	LMIX2OUT4	0	Left DAC mixer to OUT4 0 = disabled 1 = enabled
	3	LDAC2OUT4	0	Left DAC to OUT4 0 = disabled 1 = enabled
	2	BYPR2OUT4	0	Right PGA output to OUT4 0 = disabled 1 = enabled
	1	RMIX2OUT4	0	Right DAC mixer to OUT4 0 = disabled 1 = enabled
	0	RDAC2OUT4	1	Right DAC output to OUT4 0 = disabled 1 = enabled

Table 27 OUT3/OUT4 Mixer Registers

ENABLING THE OUTPUTS

Each analogue output of the WM8986 can be independently enabled or disabled. The analogue mixer associated with each output has a separate enable bit. All outputs are disabled by default. To save power, unused parts of the WM8986 should remain disabled.

Outputs can be enabled at any time, but it is not recommended to do so when BUFIO is disabled (BUFIOEN=0), as this may cause pop noise (see "Power Management" and "Applications Information" sections).

REGISTER ADDRESS	BIT	LABEL	DEFAULT	DESCRIPTION
R1 (01h) Power Management 1	2	BUFIOEN	0	Unused input/output bias buffer enable
	6	OUT3MIXEN	0	OUT3 mixer enable
	7	OUT4MIXEN	0	OUT4 mixer enable
R2 (02h) Power Management 2	8	ROUT1EN	0	ROUT1 output enable
	7	LOUT1EN	0	LOUT1 output enable
	6	SLEEP	0	0 = Normal device operation 1 = Supply current reduced in device standby mode when clock supplied (see Note)
R3 (03h) Power Management 3	2	LMIXEN	0	Left mixer enable
	3	RMIXEN	0	Right mixer enable
	5	LOUT2EN	0	LOUT2 output enable
	6	ROUT2EN	0	ROUT2 output enable
	7	OUT3EN	0	OUT3 enable
	8	OUT4EN	0	OUT4 enable
Note: All "Enable" bits are 1 = ON, 0 = OFF				

Table 28 Output Stages Power Management Control

Note: The SLEEP bit R2[6] should only be used when the device is already in Standby mode. The SLEEP bit prevents the MCLK from propagating round the device when the external MCLK signal cannot be removed.

THERMAL SHUTDOWN

To protect the WM8986 from becoming too hot, a thermal sensor has been built in. If the device junction temperature reaches approximately 125°C and the TSDEN and TSOPCTRL bit are set, then all outputs will be disabled to avoid further increase of the chip temperature.

Additionally, when the device is too hot and TSDEN is set, then the WM8986 de-asserts GPIO bit 11, a virtual GPIO that can be set up to generate an interrupt to the CPU (see "GPIO and Interrupt Control" section).

REGISTER ADDRESS	BIT	LABEL	DEFAULT	DESCRIPTION
R49 (31h) Output Control	1	TSDEN	0	Thermal Sensor Enable 0 = disabled 1 = enabled
	2	TSOPCTRL	0	Thermal Shutdown Output enable 0 = Disabled 1 = Enabled, i.e. all outputs will be disabled if T1 set and the device junction temperature is more than 125°C.

Table 29 Thermal Shutdown

UNUSED ANALOGUE INPUTS/OUTPUTS

Whenever an analogue input/output is disabled, it remains connected to a voltage source (AVDD1/2) through a resistor. This helps to prevent pop noise when the output is re-enabled. The resistance between the voltage buffer and the output pins can be controlled using the VROI control bit. The default impedance is low, so that any capacitors on the outputs can charge up quickly at start-up. If a high impedance is desired for disabled outputs, VROI can then be set to 1, increasing the resistance to about 30kΩ.

REGISTER ADDRESS	BIT	LABEL	DEFAULT	DESCRIPTION
R49 (31h)	0	VROI	0	VREF (AVDD1/2) to analogue output resistance 0 = approx 1kΩ 1 = approx 30 kΩ

Table 30 Disabled Outputs to VREF Resistance

A dedicated buffer is available for biasing unused analogue I/O pins as shown in Figure 26. This buffer can be enabled using the BUFIOEN register bit.

Figure 26 summarises the bias options for the output pins.

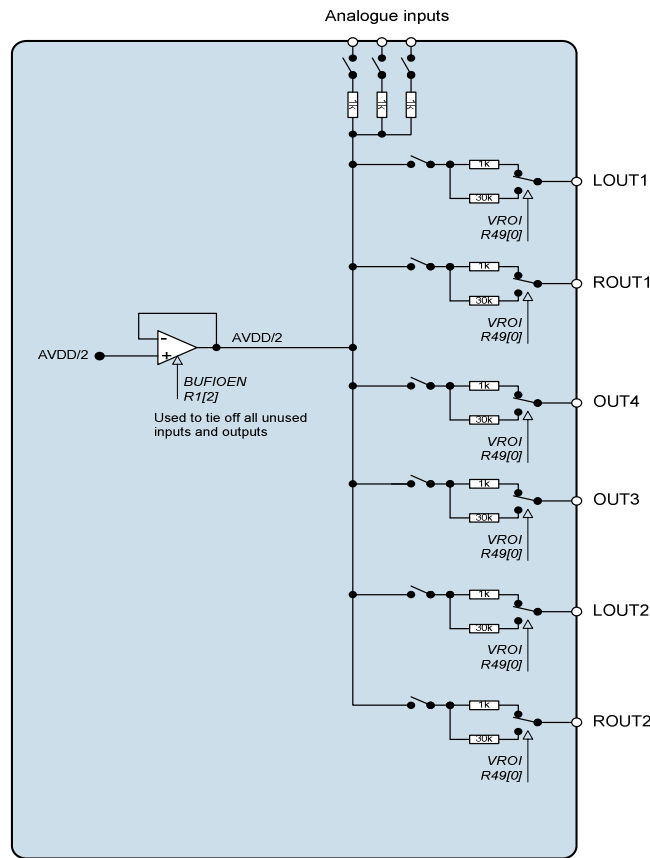

Figure 26 Unused Input/Output Pin Tie-off Buffers

L/ROUT2EN/ OUT3/4EN	VROI	OUTPUT CONFIGURATION
0	0	1kΩ to AVDD1/2
0	1	30kΩ to AVDD1/2
1	X	Output enabled (DC level=AVDD1/2)

Table 31 Unused Output Pin Bias Options

DIGITAL AUDIO INTERFACES

The audio interface has three pins:

- DACDAT: DAC data input
- LRC: Data Left/Right alignment clock
- BCLK: Bit clock, for synchronisation

The clock signals BCLK, and LRC can be outputs when the WM8986 operates as a master, or inputs when it is a slave (see Master and Slave Mode Operation, below).

Five different audio data formats are supported:

- Left justified
- Right justified
- I²S
- DSP mode A
- DSP mode B

All of these modes are MSB first. They are described in Audio Data Formats, below. Refer to the Electrical Characteristic section for timing information.

MASTER AND SLAVE MODE OPERATION

The WM8986 audio interface may be configured as either master or slave. As a master interface device the WM8986 generates BCLK and LRC and thus controls sequencing of the data transfer on DACDAT. To set the device to master mode register bit MS should be set high. In slave mode (MS=0), the WM8986 responds with data to clocks it receives over the digital audio interfaces.

AUDIO DATA FORMATS

In Left Justified mode, the MSB is available on the first rising edge of BCLK following an LRC transition. The other bits up to the LSB are then transmitted in order. Depending on word length, BCLK frequency and sample rate, there may be unused BCLK cycles before each LRC transition.

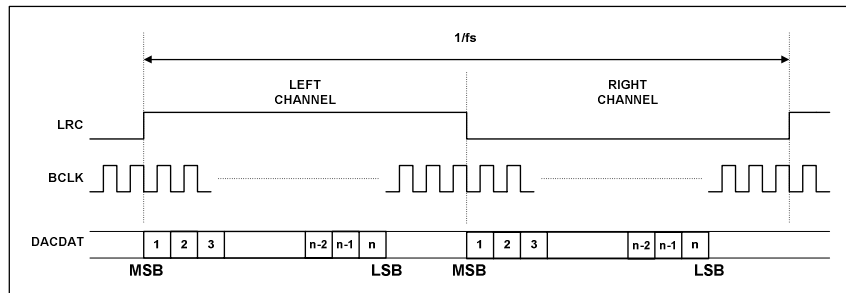

Figure 27 Left Justified Audio Interface (assuming n-bit word length)

In Right Justified mode, the LSB is available on the last rising edge of BCLK before a LRC transition. All other bits are transmitted before (MSB first). Depending on word length, BCLK frequency and sample rate, there may be unused BCLK cycles after each LRC transition.

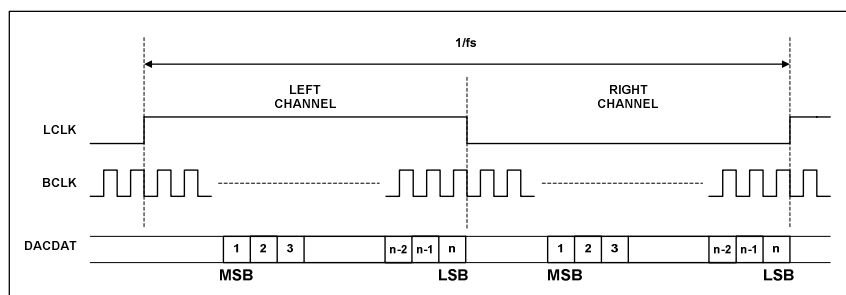

Figure 28 Right Justified Audio Interface (assuming n-bit word length)

In I²S mode, the MSB is available on the second rising edge of BCLK following a LRC transition. The other bits up to the LSB are then transmitted in order. Depending on word length, BCLK frequency and sample rate, there may be unused BCLK cycles between the LSB of one sample and the MSB of the next.

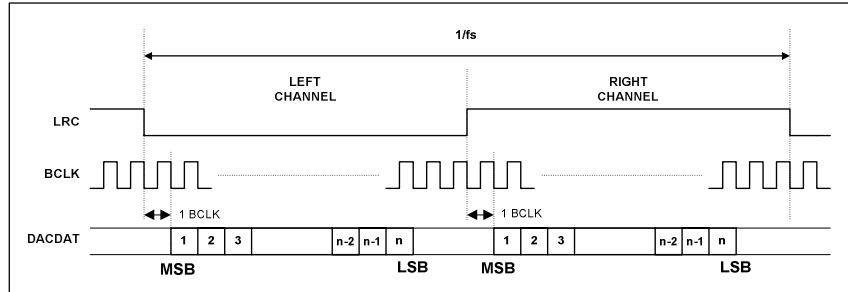

Figure 29 I²S Audio Interface (assuming n-bit word length)

In DSP/PCM mode, the left channel MSB is available on either the 1st (mode B) or 2nd (mode A) rising edge of BCLK (selectable by LRP) following a rising edge of LRC. Right channel data immediately follows left channel data. Depending on word length, BCLK frequency and sample rate, there may be unused BCLK cycles between the LSB of the right channel data and the next sample.

In device master mode, the LRC output will resemble the LRC pulse shown in Figure 30 and Figure 31. In device slave mode, Figure 32 and Figure 33, it is possible to use any length of LRC pulse less than 1/fs, providing the falling edge of the LRC pulse occurs greater than one BCLK period before the rising edge of the next LRC pulse.

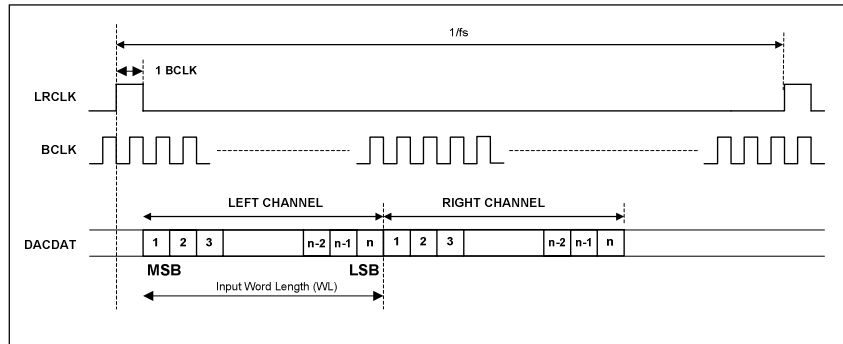

Figure 30 DSP/PCM Mode Audio Interface (mode A, LRP=0, Master)

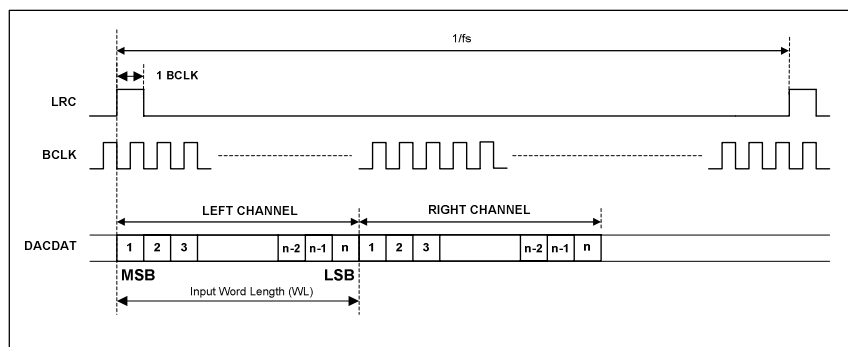

Figure 31 DSP/PCM Mode Audio Interface (mode B, LRP=1, Master)

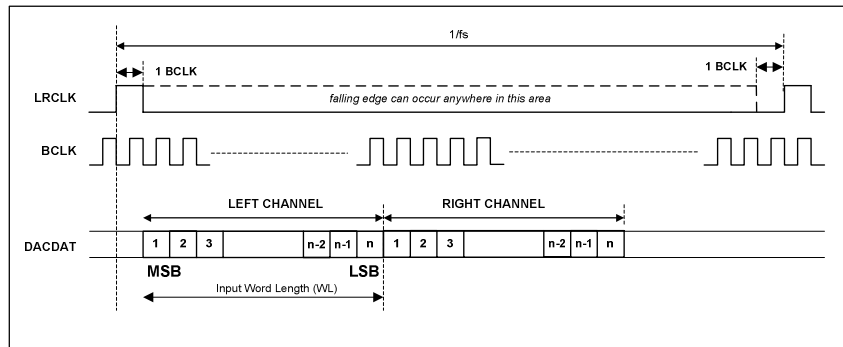

Figure 32 DSP/PCM Mode Audio Interface (mode A, LRP=0, Slave)

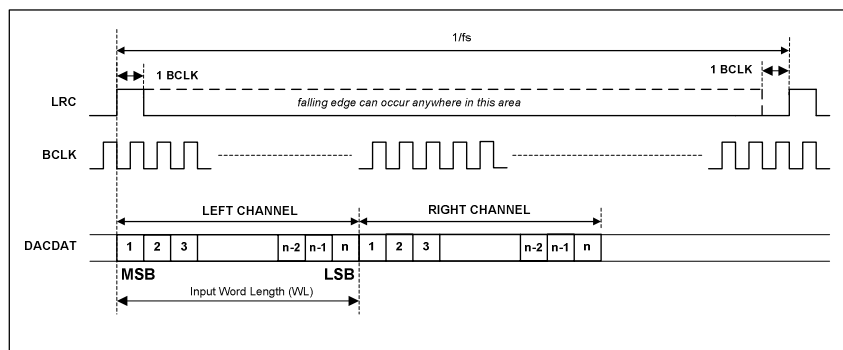

Figure 33 DSP/PCM Mode Audio Interface (mode B, LRP=0, Slave)

REGISTER ADDRESS	BIT	LABEL	DEFAULT	DESCRIPTION
R4 (04h) Audio Interface Control	0	MONO	0	Selects between stereo and mono device operation: 0 = Stereo device operation 1 = Mono device operation. Data appears in 'left' phase of LRC only.
	2	DLRSWAP	0	Controls whether DAC data appears in 'right' or 'left' phases of LRC clock: 0 = DAC left data appear in 'left' phase of LRC and right data in 'right' phase 1 = DAC left data appear in 'right' phase of LRC and right data in 'left' phase
	4:3	FMT	10	Audio interface Data Format Select: 00 = Right Justified 01 = Left Justified 10 = I ² S format 11 = DSP/PCM mode
	6:5	WL	10	Word length 00 = 16 bits 01 = 20 bits 10 = 24 bits 11 = 32 bits (see note)
	7	LRP	0	LRC clock polarity 0 = normal 1 = inverted DSP Mode – mode A/B select 0 = MSB is available on 2 nd BCLK rising edge after LRC rising edge (mode A) 1 = MSB is available on 1 st BCLK rising edge after LRC rising edge (mode B)
	8	BCP	0	BCLK polarity 0 = normal 1 = inverted

Table 32 Audio Interface Control

Note: Right Justified Mode will only operate with a maximum of 24 bits. If 32-bit mode is selected the device will operate in 24-bit mode.

AUDIO INTERFACE CONTROL

The register bits controlling audio format, word length and master / slave mode are summarised below.

Register bit MS selects audio interface operation in master or slave mode. In Master mode BCLK, and LRC are outputs. The frequency of BCLK in master mode can be controlled with BCLKDIV. The frequencies of BCLK and LRC are also controlled by MCLKDIV. The LRC sample rate is set to the required values by MCLKDIV and the BCLK rate will be set accordingly to provide sufficient BCLKs for that chosen sample rate. These clocks are divided down versions of master clock.

REGISTER ADDRESS	BIT	LABEL	DEFAULT	DESCRIPTION
R6 (06h) Clock Generation Control	0	MS	0	Sets the chip to be master over LRC and BCLK 0 = BCLK and LRC clock are inputs 1 = BCLK and LRC clock are outputs generated by the WM8986 (MASTER)
	4:2	BCLKDIV	000	Configures the BCLK output frequency, for use when the chip is master over BCLK. 000 = divide by 1 (BCLK=SYSCLK) 001 = divide by 2 (BCLK=SYSCLK/2) 010 = divide by 4 (BCLK=SYSCLK/4) 011 = divide by 8 (BCLK=SYSCLK/8) 100 = divide by 16 (BCLK=SYSCLK/16) 101 = divide by 32 (BCLK=SYSCLK/32) 110 = reserved 111 = reserved
	7:5	MCLKDIV	010	Sets the scaling for SYSCLK clock output (under control of CLKSEL) 000 = divide by 1 (LRC=SYSCLK/128) 001 = divide by 1.5 (LRC=SYSCLK/192) 010 = divide by 2 (LRC=SYSCLK/256) 011 = divide by 3 (LRC=SYSCLK/384) 100 = divide by 4 (LRC=SYSCLK/512) 101 = divide by 6 (LRC=SYSCLK/768) 110 = divide by 8 (LRC=SYSCLK/1024) 111 = divide by 12 (LRC=SYSCLK/1536)
	8	CLKSEL	1	Controls the source of the clock for all internal operation: 0 = MCLK 1 = PLL output

Table 33 Clock Control

The CLKSEL bit selects the internal source of the Master clock from the PLL (CLKSEL=1) or from MCLK (CLKSEL=0). When the internal clock is switched from one source to another using the CLKSEL bit, the clock originally selected must generate at least one falling edge after CLKSEL has changed for the switching of clocks to be successful.

EXAMPLE:

If the PLL is the current source of the internal clock (CLKSEL=1) and it is required to switch to the MCLK, change CLKSEL to select MCLK (CLKSEL=0) and then disable PLL (PLLEN=0).

AUDIO SAMPLE RATES

The WM8986 DAC limiter characteristics are sample rate dependent. SR should be set to the correct sample rate or the closest value if the actual sample rate is not available.

If a sample rate that is not explicitly supported by the SR register settings is required then the closest SR value to that sample rate should be chosen. The DAC limiter characteristics will scale appropriately.

REGISTER ADDRESS	BIT	LABEL	DEFAULT	DESCRIPTION
------------------	-----	-------	---------	-------------

R7 (07h) Additional Control	3:1	SR	000	Approximate sample rate (configures the coefficients for the internal digital filters): 000 = 48kHz 001 = 32kHz 010 = 24kHz 011 = 16kHz 100 = 12kHz 101 = 8kHz 110-111 = reserved
--------------------------------	-----	----	-----	--

Table 45 Sample Rate Control

MASTER CLOCK AND PHASE LOCKED LOOP (PLL)

The WM8986 has an on-chip phase-locked loop (PLL) circuit that can be used to:

Generate master clocks for the WM8986 audio functions from another external clock, e.g. in telecoms applications.

Generate and output (on pin CSB/GPIO1) a clock for another part of the system that is derived from an existing audio master clock.

Figure shows the PLL and internal clocking on the WM8986.

The PLL can be enabled or disabled by the PLEN register bit.

REGISTER ADDRESS	BIT	LABEL	DEFAULT	DESCRIPTION
R1 (01h) Power management 1	5	PLEN	0	PLL enable 0 = PLL off 1 = PLL on

Table 46 PLEN Control Bit

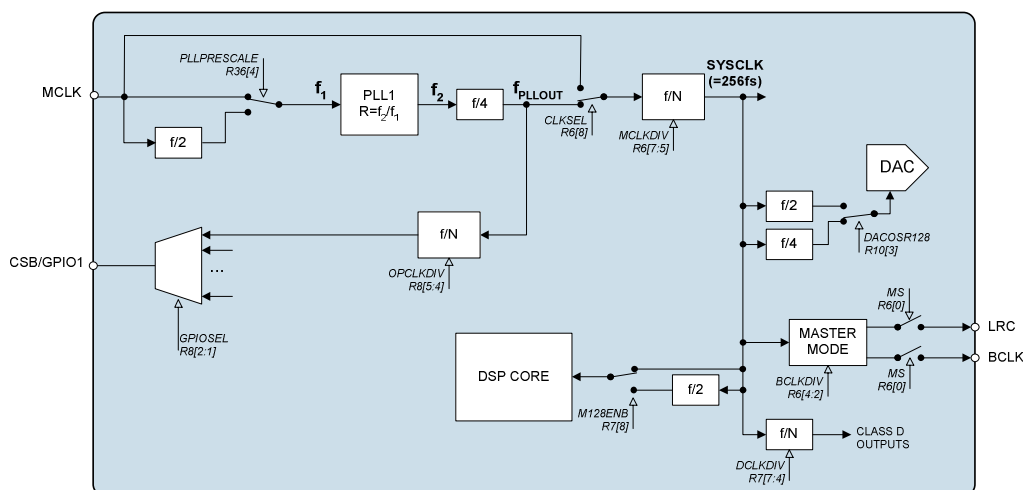

Figure 38 PLL and Clock Select Circuit

The PLL frequency ratio $R = f_2/f_1$ (see Figure) can be set using the register bits PLLK and PLLN:

$$PLLN = \text{int } R$$

$$PLLK = \text{int } (2^{24} (R - PLLN))$$

EXAMPLE:

MCLK=12MHz, required clock = 12.288MHz.

R should be chosen to ensure $5 < PLLN < 13$. There is a fixed divide by 4 in the PLL and a

selectable divide by N after the PLL which should be set to divide by 2 to meet this requirement.

Enabling the divide by 2 sets the required $f_2 = 4 \times 2 \times 12.288\text{MHz} = 98.304\text{MHz}$.

$$R = 98.304 / 12 = 8.192$$

$$\text{PLLN} = \text{int } R = 8$$

$$k = \text{int} (2^{24} \times (8.192 - 8)) = 3221225 = 3126\text{E9h}$$

REGISTER ADDRESS	BIT	LABEL	DEFAULT	DESCRIPTION
R36 (24h) PLL N value	4	PLLPRESCALE	0	0 = MCLK input not divided (default) 1 = Divide MCLK by 2 before input to PLL
	3:0	PLLN	1000	Integer (N) part of PLL input/output frequency ratio. Use values greater than 5 and less than 13.
R37 (25h) PLL K value 1	5:0	PLLK [23:18]	0Ch	Fractional (K) part of PLL1 input/output frequency ratio (treat as one 24-digit binary number).
R38 (26h) PLL K Value 2	8:0	PLLK [17:9]	093h	
R39 (27h) PLL K Value 3	8:0	PLLK [8:0]	0E9h	

Table 47 PLL Frequency Ratio Control

The PLL performs best when f_2 is around 90MHz. Its stability peaks at N=8. Some example settings are shown in 48.

MCLK (MHz) (f1)	DESIRED OUTPUT (SYSCLK) (MHz)	f2 (MHz)	PLLPRESCALE	MCLKDIV	R	N	K	N REGISTER R36[3:0]	K REGISTERS		
									R37	R38	R39
12	11.29	90.3168	1	2	7.5264	7h	86C226h	XX7h	021h	161h	026h
12	12.288	98.304	1	2	8.192	8h	3126E8h	XX8h	00Ch	093h	0E8h
13	11.29	90.3168	1	2	6.947446	6h	F28BD4h	XX6h	03Ch	145h	1D4h
13	12.288	98.304	1	2	7.561846	7h	8FD525h	XX7h	023h	1EAh	125h
14.4	11.29	90.3168	1	2	6.272	6h	45A1CAh	XX6h	011h	0D0h	1CAh
14.4	12.288	98.304	1	2	6.826667	6h	D3A06Eh	XX6h	034h	1D0h	06Eh
19.2	11.29	90.3168	2	2	9.408	9h	6872AFh	XX9h	01Ah	039h	0AFh
19.2	12.288	98.304	2	2	10.24	Ah	3D70A3h	XXAh	00Fh	0B8h	0A3h
19.68	11.29	90.3168	2	2	9.178537	9h	2DB492h	XX9h	00Bh	0DAh	092h
19.68	12.288	98.304	2	2	9.990243	9h	FD809Fh	XX9h	03Fh	0C0h	09Fh
19.8	11.29	90.3168	2	2	9.122909	9h	1F76F7h	XX9h	007h	1BBh	0F7h
19.8	12.288	98.304	2	2	9.929697	9h	EE009Eh	XX9h	03Bh	100h	09Eh
24	11.29	90.3168	2	2	7.5264	7h	86C226h	XX7h	021h	161h	026h
24	12.288	98.304	2	2	8.192	8h	3126E8h	XX8h	00Ch	093h	0E8h
26	11.29	90.3168	2	2	6.947446	6h	F28BD4h	XX6h	03Ch	145h	1D4h
26	12.288	98.304	2	2	7.561846	7h	8FD525h	XX7h	023h	1EAh	125h
27	11.29	90.3168	2	2	6.690133	6h	B0AC93h	XX6h	02Ch	056h	093h
27	12.288	98.304	2	2	7.281778	7h	482296h	XX7h	012h	011h	096h

Table 48 PLL Frequency Examples

COMPANDING

The WM8986 supports A-law and μ -law companding. Companding can be enabled on the DAC audio interface by writing the appropriate value to the DAC_COMP register bit.

REGISTER ADDRESS	BIT	LABEL	DEFAULT	DESCRIPTION
R5 (05h) Companding Control	4:3	DAC_COMP	0	DAC companding 00 = off 01 = reserved 10 = μ -law 11 = A-law
	5	WL8	0	0 = off 1 = device operates in 8-bit mode.

Table 49 Companding Control

Companding involves using a piecewise linear approximation of the following equations (as set out by ITU-T G.711 standard) for data compression:

μ -law (where $\mu=255$ for the U.S. and Japan):

$$F(x) = \ln(1 + \mu|x|) / \ln(1 + \mu) \quad -1 \leq x \leq 1$$

law (where $A=87.6$ for Europe):

$$F(x) = A|x| / (1 + \ln A) \quad \text{for } x \leq 1/A$$

$$F(x) = (1 + \ln A|x|) / (1 + \ln A) \quad \text{for } 1/A \leq x \leq 1$$

The companded data is also inverted as recommended by the G.711 standard (all 8 bits are inverted for μ -law, all even data bits are inverted for A-law). The data will be transmitted as the first 8 MSB's of data.

Companding converts 13 bits (μ -law) or 12 bits (A-law) to 8 bits using non-linear quantization. The input data range is separated into 8 levels, allowing low amplitude signals better precision than that of high amplitude signals. This is to exploit the operation of the human auditory system, where louder sounds do not require as much resolution as quieter sounds. The companded signal is an 8-bit word containing sign (1-bit), exponent (3-bits) and mantissa (4-bits).

Setting the WL8 register bit allows the device to operate with 8-bit data. In this mode it is possible to use 8 BCLK's per LRC frame. When using DSP mode B, this allows 8-bit data words to be output consecutively every 8 BCLK's and can be used with 8-bit data words using the A-law and μ -law companding functions.

BIT7	BIT[6:4]	BIT[3:0]
SIGN	EXPONENT	MANTISSA

Table 50 8-bit Companded Word Composition

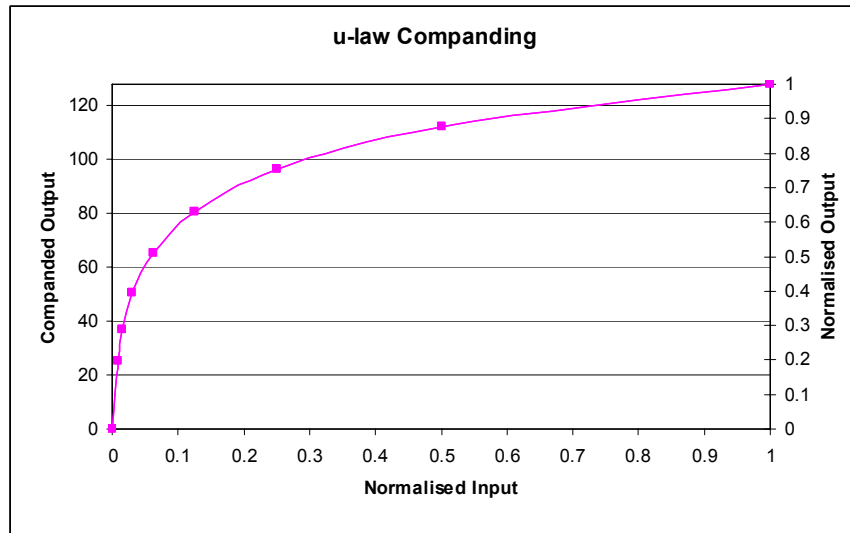

Figure 39 μ -Law Comanding

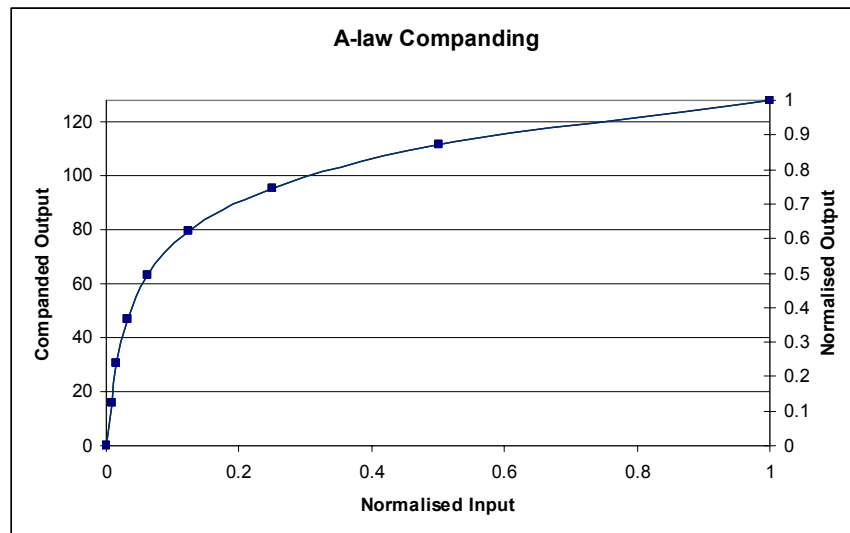

Figure 40 A-Law Comanding

GENERAL PURPOSE INPUT/OUTPUT

The WM8986 has one dual purpose input/output pin, CSB/GPIO1.

The GPIO1 function is provided for use as jack detection input or general purpose output.

The default configuration for the CSB/GPIO1 is to be an input.

When setup as an input, the CSB/GPIO1 pin can either be used as CSB or for jack detection, depending on how the MODE pin is set.

Table 34 illustrates the functionality of the GPIO1 pin when used as a general purpose output.

REGISTER ADDRESS	BIT	LABEL	DEFAULT	DESCRIPTION
R8 (08h) GPIO Control	2:0	GPIO1SEL	000	CSB/GPIO1 pin function select: 000 = input (CSB / Jack detection: depending on MODE setting) 001 = reserved 010 = Temp ok 011 = Amute active 100 = PLL clk output 101 = PLL lock 110 = logic 0 111 = logic 1
	3	GPIO1POL	0	GPIO1 Polarity invert 0 = Non inverted 1 = Inverted
	6	GPIO1GPD	0	GPIO1 Internal pull-down enable: 0 = Internal pull-down disabled 1 = Internal pull-down enabled
	7	GPIO1GPU	0	GPIO1 Internal pull-up enable: 0 = Internal pull-up disabled 1 = Internal pull-up enabled
	8	GPIO1GP	0	GPIO1 Open drain enable 0 = Open drain disabled 1 = Open drain enabled
R14(0Eh) GPIO Control	5:4	OPCLKDIV	00	PLL Output clock division ratio 00 = divide by 1 01 = divide by 2 10 = divide by 3 11 = divide by 4

Table 34 CSB/GPIO Control

Note: If MODE is set to 3 wire mode, CSB/GPIO1 is used as CSB input irrespective of the GPIO1SEL[2:0] bits.

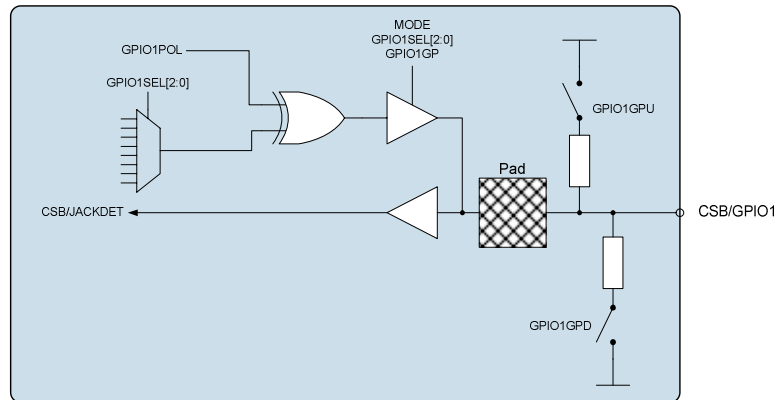

For further details of the jack detect operation see the OUTPUT SWITCHING section.

OUTPUT SWITCHING (JACK DETECT)

When the device is operated using a 2-wire interface the CSB/GPIO1 pin can be used as a switch control input to automatically disable one set of outputs and enable another; the most common use for this functionality is as jack detect circuitry.

The GPIO pins have an internal de-bounce circuit when in this mode in order to prevent the output enables from toggling multiple times due to input glitches. This de-bounce circuit is clocked from a slow clock with period $2^{21} \times \text{MCLK}$ and is enabled by the SLOWCLKEN bit.

Notes:

The SLOWCLKEN bit must be enabled for the jack detect circuitry to operate.

The GPIOPOL bit is not relevant for jack detection, it is the signal detected at the pin which is used

Switching on/off of the outputs is fully configurable by the user. Each output, OUT1, OUT2, OUT3 and OUT4 has 2 associated enables. OUT1_EN_0, OUT2_EN_0, OUT3_EN_0 and OUT4_EN_0 are the output enable signals which are used if the selected jack detection pin is at logic 0 (after de-bounce). OUT1_EN_1, OUT2_EN_1, OUT3_EN_1 and OUT4_EN_1 are the output enable signals which are used if the selected jack detection pin is at logic 1 (after de-bounce).

The jack detection enables operate as follows:

All OUT_EN signals have an AND function performed with their normal enable signals (in Table 28). When an output is normally enabled at per Table 28, the selected jack detection enable (controlled by selected jack detection pin polarity) is set 0; it will turn the output off. If the normal enable signal is already OFF (0), the jack detection signal will have no effect due to the AND function.

During jack detection if the user desires an output to be un-changed whether the jack is in or not, both the JD_EN settings, i.e. JD_EN0 and JD_EN1, should be set to 0000.

If jack detection is not enabled (JD_EN=0), the output enables default to all 1's, allowing the outputs to be controlled as normal via the normal output enables found in Table 28.

REGISTER ADDRESS	BIT	LABEL	DEFAULT	DESCRIPTION
R9 (09h) GPIO control	6	JD_EN	0	Jack Detection Enable 0 = disabled 1 = enabled
R13 (00h)	3:0	JD_EN0	0000	Output enables when selected jack detection input is logic 0. [0]= OUT1_EN_0 [1]= OUT2_EN_0 [2]= OUT3_EN_0 [3]= OUT4_EN_0
	7:4	JD_EN1	0000	Output enables when selected jack detection input is logic 1 [4]= OUT1_EN_1 [5]= OUT2_EN_1 [6]= OUT3_EN_1 [7]= OUT4_EN_1

Table 35 Jack Detect Register Control Bits

CONTROL INTERFACE

SELECTION OF CONTROL MODE AND 2-WIRE MODE ADDRESS

The control interface can operate as either a 3-wire or 2-wire control interface. The MODE pin determines the 2 or 3 wire mode as shown in Table 36.

The WM8986 is controlled by writing to registers through a serial control interface. A control word consists of 16 bits. The first 7 bits (B15 to B9) are register address bits that select which control register is accessed. The remaining 9 bits (B8 to B0) are data bits, corresponding to the 9 data bits in each control register.

MODE	INTERFACE FORMAT
Low	2 wire
High	3 wire

Table 36 Control Interface Mode Selection

3-WIRE SERIAL CONTROL MODE

In 3-wire mode, every rising edge of SCLK clocks in one data bit from the SDIN pin. A rising edge on CSB/GPIO latches in a complete control word consisting of the last 16 bits.

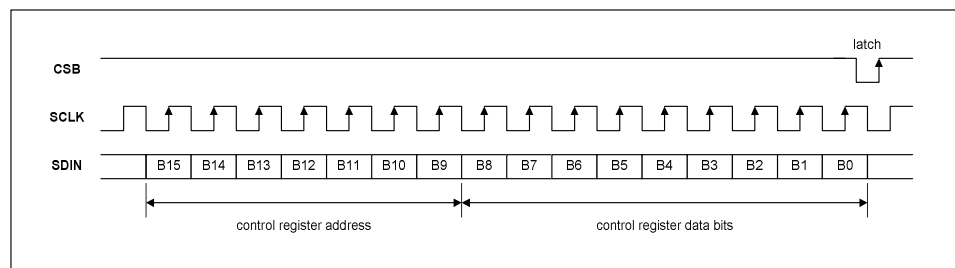

Figure 34 3-Wire Serial Control Interface

2-WIRE SERIAL CONTROL MODE

The WM8986 supports software control via a 2-wire serial bus. Many devices can be controlled by the same bus, and each device has a unique 7-bit device address (this is not the same as the 7-bit address of each register in the WM8986).

The WM8986 operates as a slave device only. The controller indicates the start of data transfer with a high to low transition on SDIN while SCLK remains high. This indicates that a device address and data will follow. All devices on the 2-wire bus respond to the start condition and shift in the next eight bits on SDIN (7-bit address + Read/Write bit, MSB first). If the device address received matches the address of the WM8986, the WM8986 responds by pulling SDIN low on the next clock pulse (ACK). If the address is not recognised or the R/W bit is '1' when operating in write only mode, the WM8986 returns to the idle condition and waits for a new start condition and valid address.

During a write, once the WM8986 has acknowledged a correct address, the controller sends the first byte of control data (B15 to B8, i.e. the WM8986 register address plus the first bit of register data). The WM8986 then acknowledges the first data byte by driving SDIN low for one clock cycle. The controller then sends the second byte of control data (B7 to B0, i.e. the remaining 8 bits of register data), and the WM8986 acknowledges again by pulling SDIN low.

Transfer is complete when there is a low to high transition on SDIN while SCLK is high. After a complete sequence the WM8986 returns to the idle state and waits for another start condition. If a start or stop condition is detected out of sequence at any point during data transfer (i.e. SDIN changes while SCLK is high), the control interface returns to the idle condition.

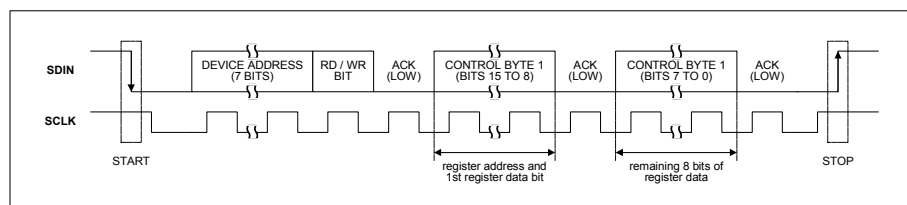

Figure 35 2-Wire Serial Control Interface

In 2-wire mode the WM8986 has a fixed device address, 0011010.

RESETTING THE CHIP

The WM8986 can be reset by performing a write of any value to the software reset register (address 0h). This will cause all register values to be reset to their default values. In addition to this there is a Power-On Reset (POR) circuit which ensures that the registers are initially set to default when the device is powered up.

POWER SUPPLIES

The WM8986 requires four separate power supplies:

AVDD1 and AGND1: Analogue supply, powers all internal analogue functions and output drivers LOUT1, ROUT1, OUT3 and OUT4. AVDD1 must be between 2.5V and 3.6V and has the most significant impact on overall power consumption (except for power consumed in the headphones). Higher AVDD1 will improve audio quality.

AVDD2 and AGND2: Output driver supplies, power LOUT2 and ROUT2. AVDD2 must be between 2.5V and 3.6V. AVDD2 can be tied to AVDD1, but it requires separate layout and decoupling capacitors to curb harmonic distortion.

DCVDD: Digital core supply, powers all digital functions except the audio and control interface pads. DCVDD must be between 1.71V and 3.6V, and has no effect on audio quality. The return path for DCVDD is DGND, which is shared with DBVDD.

DBVDD must be between 1.71V and 3.6V. DBVDD return path is through DGND.

It is possible to use the same supply voltage for all four supplies. However, digital and analogue supplies should be routed and decoupled separately on the PCB to keep digital switching noise out of the analogue signal paths.

POWER MANAGEMENT

SAVING POWER BY REDUCING OVERSAMPLING RATE

The default mode of operation of the DAC digital filters is in 64x oversampling mode. Under the control of DACOSR128 the oversampling rate may be doubled. 64x oversampling results in a slight decrease in noise performance compared to 128x but lowers the power consumption of the device.

REGISTER ADDRESS	BIT	LABEL	DEFAULT	DESCRIPTION
R10 (0Ah) DAC control	3	DACOSR128	0	DAC oversample rate select 0 = 64x (lowest power) 1 = 128x (best SNR)

Table 37 DAC Oversampling Rate Selection

LOW POWER MODE

If only limited functionality is required, the WM8986 can be put into a low power mode. In this mode, the DSP core runs at half of the normal rate, reducing digital power consumption of the core by half. For DAC low power only, 3D enhancement with 2-Band equaliser functionality is permitted, where only Band 1 (low shelf) and Band 5 (high shelf) can be used.

REGISTER ADDRESS	BIT	LABEL	DEFAULT	DESCRIPTION
R7 (07h) Additional Ctrl	8	M128ENB	0	0 = low power mode enabled 1 = low power mode disabled

Table 38 DSP Core Low Power Mode Control

The register settings for this low-power mode are detailed below. The device will not enter low power unless in this register configuration, regardless of M128ENB.

For pop-free operation of the device it is recommended to change the M128ENB low power functionality only when both DACs are disabled, i.e. when DACENL=0 and DACENR=0.

FUNCTION	REGISTER BITS	SETTING	DESCRIPTION
DAC low power	M128ENB	0	Either or both of DACENL and DACENR must be set (mono or stereo mode)
	DACENL	1	
	DACENR	1	

Table 39 DSP Core Low Power Mode Register Settings

VMID

The analogue circuitry will not operate unless VMID is enabled. The impedance of the VMID resistor string, together with the decoupling capacitor on the VMID pin will determine the start-up time of the VMID circuit.

REGISTER ADDRESS	BIT	LABEL	DEFAULT	DESCRIPTION
R1 (01h) Power management 1	1:0	VMIDSEL	00	Reference string impedance to VMID pin 00= off (250kΩ VMID to AGND1) 01=75kΩ 10=300kΩ 11=5kΩ

Table 40 VMID Impedance Control

BIASEN

The analogue amplifiers will not operate unless BIASEN is enabled.

REGISTER ADDRESS	BIT	LABEL	DEFAULT	DESCRIPTION
R1 (01h) Power management 1	3	BIASEN	0	Analogue amplifier bias control 0 = disabled 1 = enabled

Table 41 Analogue Bias Control

REGISTER MAP

ADDR B[15:9]		REGISTER NAME	B8	B7	B6	B5	B4	B3	B2	B1	B0	DEFAULT VAL (HEX)	
DEC	HEX												
0	00	Software Reset	Software reset										
1	01	Power manage't 1	0	OUT4MIX EN	OUT3MIX EN	PLLEN	0	BIASEN	BUFIOEN	VMIDSEL [1:0]		000	
2	02	Power manage't 2	ROUT1EN	LOUT1EN	SLEEP	BOOST ENR	BOOST ENL	INPGA ENR	INPPGA ENL	0	0	000	
3	03	Power manage't 3	OUT4EN	OUT3EN	ROUT2EN	LOUT2EN	0	RMIXEN	LMIXEN	DACENR	DACENL	000	
4	04	Audio Interface	BCP	LRP	WL[1:0]		FMT[1:0]		DLRSWAP	0	MONO	050	
5	05	Companding ctrl	0	0	0	WL8	DAC_COMP [1:0]		0	0	0	000	
6	06	Clock Gen ctrl	CLKSEL	MCLKDIV[2:0]			BCLKDIV[2:0]			0	MS	140	
7	07	Additional ctrl	M128ENB	DCLKDIV[3:0]				SR[2:0]			SLOWCLK EN	080	
8	08	GPIO Control	GPIO1GP	GPIO1GPU	GPIO1GPD	0	0	GPIO1POL	GPIO1SEL[2:0]			000	
9	09	Jack detect control	0	0	JD_EN	0	0	0	0	0	0	000	
10	0A	DAC Control	0	0	SOFT MUTE	0	0	DACOSR 128	AMUTE	DACRPOL	DACLPOL	000	
11	0B	Left DAC digital Vol	DACVU	DACLVOL[7:0]								OFF	
12	0C	Right DAC dig'l Vol	DACVU	DACRVOL[7:0]								OFF	
13	0D	Jack Detect Control	0	JD_EN1[3:0]				JD_EN0[3:0]				000	
14	0E	GPIO Control	0	0	0	OPCLKDIV[1:0]	0	0	0	0	000		
15	0F	Reserved	000000000										000
16	10	Reserved	000000000										000
18	12	EQ1 – low shelf	EQ3DEN	0	EQ1C[1:0]			EQ1G[4:0]				12C	
19	13	EQ2 – peak 1	EQ2BW	0	EQ2C[1:0]			EQ2G[4:0]				02C	
20	14	EQ3 – peak 2	EQ3BW	0	EQ3C[1:0]			EQ3G[4:0]				02C	
21	15	EQ4 – peak 3	EQ4BW	0	EQ4C[1:0]			EQ4G[4:0]				02C	
22	16	EQ5 – high shelf	0	0	EQ5C[1:0]			EQ5G[4:0]				02C	
23	17	Class D Control	CLASSDEN	0	0	0	0	10	0	0	008		
24	18	DAC Limiter 1	LIMEN	LIMDCY[3:0]				LIMATK[3:0]				032	
25	19	DAC Limiter 2	0	0	LIMLVL[2:0]			LIMBOOST[3:0]				000	
27	1B	Reserved	000000000										000
28	1C	Reserved	000000000										000
29	1D	Reserved	000000000										000
30	1E	Reserved	000000000										000
32	20	Reserved	000000000										000
33	21	Reserved	000000000										000
34	22	Reserved	000000000										000
35	23	Reserved	000000000										000
36	24	PLL N	0	0	0	0	PLLPRE SCALE	PLLN[3:0]				008	
37	25	PLL K 1	0	0	0	PLLK[23:18]						00C	
38	26	PLL K 2	PLLK[17:9]									093	
39	27	PLL K 3	PLLK[8:0]									0E9	
41	29	3D control	0	0	0	0	0	DEPTH3D[3:0]				000	
42	2A	Biasing	0	0	0	0	0	0	POBCTRL	0	0	000	
43	2B	Beep control	BYPL2 RMIX	BYPR2 LMIX	0	0	0	0	0	0	0	000	
44	2C	Input ctrl	0	0	0	RIN2 INPPGA	RIP2 INPPGA	0	0	LIN2 INPPGA	LIP2 INPPGA	003	

ADDR B[15:9]		REGISTER NAME	B8	B7	B6	B5	B4	B3	B2	B1	B0	DEFAULT VAL
DEC	HEX											(HEX)
45	2D	Left INP PGA gain ctrl	INPGAVU	INPPGA ZCL	INPPGA MUTEL	INPPGAVOLL[5:0]					010	
46	2E	Right INP PGA gain ctrl	INPGAVU	INPPGA ZCR	INPPGA MUTER	INPPGAVOLR[5:0]					010	
47	2F	Left Input BOOST control	PGA BOOSTL	0	0	0	0	0	AUXL2BOOSTVOL[2:0]			100
48	30	Right Input BOOST control	PGA BOOSTR	0	0	0	0	0	AUXR2BOOSTVOL[2:0]			100
49	31	Output ctrl	0	0	DACL2 RMIX	DACR2 LMIX	0	0	TSOP CTRL	TSDEN	VROI	002
50	32	Left mixer ctrl	AUXLMIXVOL[2:0]			AUXL2 LMIX	BYPLMIXVOL[2:0]			BYPL2 LMIX	DACL2 LMIX	001
51	33	Right mixer ctrl	AUXRMIXVOL[2:0]			AUXR2 RMIX	BYPRMIXVOL[2:0]			BYPR2 RMIX	DACR2 RMIX	001
52	34	LOUT1 (HP) volume ctrl	OUT1VU	LOUT1ZC	LOUT1 MUTE	LOUT1VOL[5:0]					039	
53	35	ROUT1 (HP) volume ctrl	OUT1VU	ROUT1ZC	ROUT1 MUTE	ROUT1VOL[5:0]					039	
54	36	LOUT2 (SPK) volume ctrl	OUT2VU	LOUT2ZC	LOUT2 MUTE	LOUT2VOL[5:0]					039	
55	37	ROUT2 (SPK) volume ctrl	OUT2VU	ROUT2ZC	ROUT2 MUTE	ROUT2VOL[5:0]					039	
56	38	OUT3 mixer ctrl	0	0	OUT3 MUTE	0	0	OUT4_ 2OUT3	BYPL2 OUT3	LMIX2 OUT3	LDAC2 OUT3	001
57	39	OUT4 (MONO) mixer ctrl	0	OUT 3_2OUT4	OUT4 MUTE	OUT4 ATTN	LMIX2 OUT4	LDAC2 OUT4	BYPR2 OUT4	RMIX2 OUT4	RDAC2 OUT4	001
61	3D	Bias Control	BIASCUT	0	0	0	00		00		0	000

Table 42 WM8986 Register Map

REGISTER BITS BY ADDRESS

Notes:

1. Default values of N/A indicate non-latched data bits (e.g. software reset or volume update bits).
2. Register bits marked as "Reserved" should not be changed from the default.

REGISTER ADDRESS	BIT	LABEL	DEFAULT	DESCRIPTION	REFER TO
0 (00h)	[8:0]	RESET	N/A	Software reset	Resetting the Chip
1 (01h)	8		0	Reserved	Analogue Outputs
	7	OUT4MIXEN	0	OUT4 mixer enable 0=disabled 1=enabled	Power Management
	6	OUT3MIXEN	0	OUT3 mixer enable 0=disabled 1=enabled	Power Management
	5	PLEN	0	PLL enable 0=PLL off 1=PLL on	Master Clock and Phase Locked Loop (PLL)
	4		0	Reserved	
	3	BIASEN	0	Analogue amplifier bias control 0=disabled 1=enabled	Power Management
	2	BUFIOEN	0	Unused input/output tie off buffer enable 0=disabled 1=enabled	Power Management
	1:0	VMIDSEL	00	Reference string impedance to VMID pin 00= off (250kΩ VMID to AGND1) 01=75kΩ 10=300kΩ 11=5kΩ	Power Management
2 (02h)	8	ROUT1EN	0	ROUT1 output enable 0=disabled 1=enabled	Power Management
	7	LOUT1EN	0	LOUT1 output enable 0=disabled 1=enabled	Power Management
	6	SLEEP	0	0 = normal device operation 1 = residual current reduced in device standby mode (Device must be in standby mode before setting this bit)	Power Management
	5	BOOSTENR	0	Right channel Input BOOST enable 0 = Boost stage OFF 1 = Boost stage ON	Power Management
	4	BOOSTENL	0	Left channel Input BOOST enable 0 = Boost stage OFF 1 = Boost stage ON	Power Management
	3	INPPGAENR	0	Right channel input PGA enable 0 = disabled 1 = enabled	Power Management
	2	INPPGAENL	0	Left channel input PGA enable 0 = disabled 1 = enabled	Power Management
	1		0	Reserved	
	0		0	Reserved	

REGISTER ADDRESS	BIT	LABEL	DEFAULT	DESCRIPTION	REFER TO
3 (03h)	8	OUT4EN	0	OUT4 enable 0 = disabled 1 = enabled	Power Management
	7	OUT3EN	0	OUT3 enable 0 = disabled 1 = enabled	Power Management
	6	ROUT2EN	0	ROUT2 enable 0 = disabled 1 = enabled	Power Management
	5	LOUT2EN	0	LOUT2 enable 0 = disabled 1 = enabled	Power Management
	4		0	Reserved	
	3	RMIXEN	0	Right output channel mixer enable: 0 = disabled 1 = enabled	Analogue Outputs
	2	LMIXEN	0	Left output channel mixer enable: 0 = disabled 1 = enabled	Analogue Outputs
	1	DACENR	0	Right channel DAC enable 0 = DAC disabled 1 = DAC enabled	Analogue Outputs
	0	DACENL	0	Left channel DAC enable 0 = DAC disabled 1 = DAC enabled	Analogue Outputs
4 (04h)	8	BCP	0	BCLK polarity 0=normal 1=inverted	Digital Audio Interfaces
	7	LRP	0	LRC clock polarity 0=normal 1=inverted	Digital Audio Interfaces
	6:5	WL	10	Word length 00=16 bits 01=20 bits 10=24 bits 11=32 bits	Digital Audio Interfaces
	4:3	FMT	10	Audio interface Data Format Select: 00=Right Justified 01=Left Justified 10=I ² S format 11= DSP/PCM mode	Digital Audio Interfaces
	2	DLRSWAP	0	Controls whether DAC data appears in 'right' or 'left' phases of LRC clock: 0=DAC data appear in 'left' phase of LRC 1=DAC data appears in 'right' phase of LRC	Digital Audio Interfaces
	1		0	Reserved	
	0	MONO	0	Selects between stereo and mono device operation: 0=Stereo device operation 1=Mono device operation. Data appears in 'left' phase of LRC	Digital Audio Interfaces
5 (05h)	8:6		000	Reserved	

REGISTER ADDRESS	BIT	LABEL	DEFAULT	DESCRIPTION	REFER TO
	5	WL8	0	Companding Control 8-bit mode 0=off 1=device operates in 8-bit mode	Digital Audio Interfaces
	4:3	DAC_COMP	00	DAC companding 00=off (linear mode) 01=reserved 10= μ -law 11=A-law	Digital Audio Interfaces
	2:0		000	Reserved	
6 (06h)	8	CLKSEL	1	Controls the source of the clock for all internal operation: 0=MCLK 1=PLL output	Digital Audio Interfaces
	7:5	MCLKDIV	010	Sets the scaling for either the MCLK or PLL clock output (under control of CLKSEL) 000=divide by 1 001=divide by 1.5 010=divide by 2 011=divide by 3 100=divide by 4 101=divide by 6 110=divide by 8 111=divide by 12	Digital Audio Interfaces
	4:2	BCLKDIV	000	Configures the BCLK output frequency, for use when the chip is master over BCLK. 000=divide by 1 (BCLK=MCLK) 001=divide by 2 (BCLK=MCLK/2) 010=divide by 4 011=divide by 8 100=divide by 16 101=divide by 32 110=reserved 111=reserved	Digital Audio Interfaces
	1		0	Reserved	
	0	MS	0	Sets the chip to be master over LRC and BCLK 0=BCLK and LRC clock are inputs 1=BCLK and LRC clock are outputs generated by the WM8978 (MASTER)	Digital Audio Interfaces
7 (07h)	8	M128ENB	0	0 = low power mode enabled 1 = low power mode disabled	Additional Control
	7:4	DCLKDIV	1000	Controls clock division from SYSCLK to generate suitable class D clock. Recommended class D clock frequency = 1.4MHz. 0000 = divide by 1 0010 = divide by 2 0011 = divide by 3 0100 = divide by 4 0101 = divide by 5.5 0110 = divide by 6 1000 = divide by 8 1001 = divide by 12 1010 = divide by 16	Class A / D Headphone Outputs

REGISTER ADDRESS	BIT	LABEL	DEFAULT	DESCRIPTION	REFER TO
	3:1	SR	000	Approximate sample rate (configures the coefficients for the internal digital filters): 000=48kHz 001=32kHz 010=24kHz 011=16kHz 100=12kHz 101=8kHz 110-111=reserved	Audio Sample Rates
	0	SLOWCLKEN	0	Slow clock enable. Used for both the jack insert detect debounce circuit and the zero cross timeout. 0 = slow clock disabled 1 = slow clock enabled	Analogue Outputs
8 (08h)	8	GPIO1GP	0	GPIO1 Open drain enable 0 = Open drain disabled 1 = Open drain enabled	General Purpose Input/Output (GPIO)
	7	GPIO1GPU	0	GPIO1 Internal pull-up enable: 0 = Internal pull-up disabled 1 = Internal pull-up enabled	General Purpose Input/Output (GPIO)
	6	GPIO1GPD	0	GPIO1 Internal pull-down enable: 0 = Internal pull-down disabled 1 = Internal pull-down enabled	General Purpose Input/Output (GPIO)
	3	GPIO1POL	0	GPIO1 Polarity invert 0=Non inverted 1=Inverted	General Purpose Input/Output (GPIO)
	2:0	GPIO1SEL [2:0]	000	CSB/GPIO1 pin function select: 000= input (CSB/jack detection: depending on MODE setting) 001= reserved 010=Temp ok 011=Amute active 100=PLL clk o/p 101=PLL lock 110=logic 1 111=logic 0	General Purpose Input/Output (GPIO)
9 (09h)	8:7		00	Reserved	
	6	JD_EN	0	Jack Detection Enable 0=disabled 1=enabled	Output Switching (Jack Detect)
	5:0		000000	Reserved	Output Switching (Jack Detect)
10 (0Ah)	8:7		00	Reserved	
	6	SOFTMUTE	0	Softmute enable: 0=Disabled 1=Enabled	Output Signal Path
	5:4		00	Reserved	
	3	DACOSR128	0	DAC oversample rate select 0 = 64x (lowest power) 1 = 128x (best SNR)	Power Management

REGISTER ADDRESS	BIT	LABEL	DEFAULT	DESCRIPTION	REFER TO
	2	AMUTE	0	Automute enable 0 = Amute disabled 1 = Amute enabled	Output Signal Path
	1	DACPOLR	0	Right DAC output polarity: 0 = non-inverted 1 = inverted (180 degrees phase shift)	Output Signal Path
	0	DACPOLL	0	Left DAC output polarity: 0 = non-inverted 1 = inverted (180 degrees phase shift)	Output Signal Path
11 (0Bh)	8	DACVU	N/A	DAC left and DAC right volume do not update until a 1 is written to DACVU (in reg 11 or 12)	Digital to Analogue Converter (DAC)
	7:0	DACVOLL	11111111	Left DAC Digital Volume Control 0000 0000 = Digital Mute 0000 0001 = -127dB 0000 0010 = -126.5dB ... 0.5dB steps up to 1111 1111 = 0dB	Digital to Analogue Converter (DAC)
12 (0Ch)	8	DACVU	N/A	DAC left and DAC right volume do not update until a 1 is written to DACVU (in reg 11 or 12)	Output Signal Path
	7:0	DACVOLR	11111111	Right DAC Digital Volume Control 0000 0000 = Digital Mute 0000 0001 = -127dB 0000 0010 = -126.5dB ... 0.5dB steps up to 1111 1111 = 0dB	Output Signal Path
13 (0Dh)	8		0	Reserved	
	7:4	JD_EN1	0000	Output enabled when selected jack detection input is logic 1 [4]= OUT1_EN_1 [5]= OUT2_EN_1 [6]= OUT3_EN_1 [7]= OUT4_EN_1	Output Switching (Jack Detect)
	3:0	JD_EN0	0000	Output enabled when selected jack detection input is logic 0. [0]= OUT1_EN_0 [1]= OUT2_EN_0 [2]= OUT3_EN_0 [3]= OUT4_EN_0	Output Switching (Jack Detect)
14 (0Eh)	5:4	OPCLKDIV	00	PLL Output clock division ratio 00 = divide by 1 01 = divide by 2 10 = divide by 3 11 = divide by 4	General Purpose Input/Output (GPIO)
15 (0Fh)	8:0		000000000	Reserved	
16 (10h)	8:0		000000000	Reserved	
18 (12h)	8:7		00	Reserved	EQ3DEN
	6:5	EQ1C	01	EQ Band 1 Cut-off Frequency: 00=80Hz 01=105Hz 10=135Hz 11=175Hz	Output Signal Path
	4:0	EQ1G	01100	EQ Band 1 Gain Control. See Table 20 for details.	Output Signal Path

REGISTER ADDRESS	BIT	LABEL	DEFAULT	DESCRIPTION	REFER TO
19 (13h)	8	EQ2BW	0	EQ Band 2 Bandwidth Control 0=narrow bandwidth 1=wide bandwidth	Output Signal Path
	7		0	Reserved	Output Signal Path
	6:5	EQ2C	01	EQ Band 2 Centre Frequency: 00=230Hz 01=300Hz 10=385Hz 11=500Hz	Output Signal Path
	4:0	EQ2G	01100	EQ Band 2 Gain Control. See Table 20 for details.	Output Signal Path
20 (14h)	8	EQ3BW	0	EQ Band 3 Bandwidth Control 0=narrow bandwidth 1=wide bandwidth	Output Signal Path
	7		0	Reserved	Output Signal Path
	6:5	EQ3C	01	EQ Band 3 Centre Frequency: 00=650Hz 01=850Hz 10=1.1kHz 11=1.4kHz	Output Signal Path
	4:0	EQ3G	01100	EQ Band 3 Gain Control. See Table 20 for details.	Output Signal Path
21 (15h)	8	EQ4BW	0	EQ Band 4 Bandwidth Control 0=narrow bandwidth 1=wide bandwidth	Output Signal Path
	7		0	Reserved	Output Signal Path
	6:5	EQ4C	01	EQ Band 4 Centre Frequency: 00=1.8kHz 01=2.4kHz 10=3.2kHz 11=4.1kHz	Output Signal Path
	4:0	EQ4G	01100	EQ Band 4 Gain Control. See Table 20 for details.	Output Signal Path
22 (16h)	8:7		0	Reserved	Output Signal Path
	6:5	EQ5C	01	EQ Band 5 Cut-off Frequency: 00=5.3kHz 01=6.9kHz 10=9kHz 11=11.7kHz	Output Signal Path
	4:0	EQ5G	01100	EQ Band 5 Gain Control. See Table 20 for details.	Output Signal Path
23 (17h)	8	CLASSDEN	0	Enable signal for class D mode on LOUT2 and ROUT2 0 = Class AB mode 1 = Class D mode	Class D Control
	7:0		000 0000	Reserved. Initialise to 0	
24 (18h)	8	LIMEN	0	Enable the DAC digital limiter: 0=disabled 1=enabled	Output Signal Path

REGISTER ADDRESS	BIT	LABEL	DEFAULT	DESCRIPTION	REFER TO
	7:4	LIMDCY	0011	DAC Limiter Decay time (per 6dB gain change) for 44.1kHz sampling. Note that these will scale with sample rate: 0000=750us 0001=1.5ms 0010=3ms 0011=6ms 0100=12ms 0101=24ms 0110=48ms 0111=96ms 1000=192ms 1001=384ms 1010=768ms	Output Signal Path
	3:0	LIMATK	0010	DAC Limiter Attack time (per 6dB gain change) for 44.1kHz sampling. Note that these will scale with sample rate. 0000=94us 0001=188s 0010=375us 0011=750us 0100=1.5ms 0101=3ms 0110=6ms 0111=12ms 1000=24ms 1001=48ms 1010=96ms 1011 to 1111=192ms	Output Signal Path
25 (19h)	8:7		00	Reserved	
	6:4	LIMLVL	000	Programmable signal threshold level (determines level at which the DAC limiter starts to operate) 000=-1dB 001=-2dB 010=-3dB 011=-4dB 100=-5dB 101 to 111=-6dB	Output Signal Path
	3:0	LIMBOOST	0000	DAC Limiter volume boost (can be used as a stand alone volume boost when LIMEN=0): 0000=0dB 0001=+1dB 0010=+2dB ... (1dB steps) 1011=+11dB 1100=+12dB 1101 to 1111=reserved	Output Signal Path
27 (1Bh)	8:0		000000000	Reserved	
28 (1Ch)	8:0		000000000	Reserved	
29 (1Dh)	8:0		000000000	Reserved	
30 (1Eh)	8:0		000000000	Reserved	
32 (20h)	8:0		000000000	Reserved	
33 (21h)	8:0		000000000	Reserved	8

REGISTER ADDRESS	BIT	LABEL	DEFAULT	DESCRIPTION	REFER TO
34 (22h)	8:0		000000000	Reserved	
35 (23h)	8:0		000000000	Reserved	
36 (24h)	8:5		0000	Reserved	
	4	PLL PRESCALE	0	Divide MCLK by 2 before input to PLL	Master Clock and Phase Locked Loop (PLL)
	3:0	PLLN[3:0]	1000	Integer (N) part of PLL input/output frequency ratio. Use values greater than 5 and less than 13.	Master Clock and Phase Locked Loop (PLL)
37 (25h)	8:6		000	Reserved	
	5:0	PLLK[23:18]	01100	Fractional (K) part of PLL1 input/output frequency ratio (treat as one 24-digit binary number).	Master Clock and Phase Locked Loop (PLL)
38 (26h)	8:0	PLLK[17:9]	010010011	Fractional (K) part of PLL1 input/output frequency ratio (treat as one 24-digit binary number).	Master Clock and Phase Locked Loop (PLL)
39 (27h)	8:0	PLLK[8:0]	011101001	Fractional (K) part of PLL1 input/output frequency ratio (treat as one 24-digit binary number).	Master Clock and Phase Locked Loop (PLL)
41 (29h)	8:4		00000	Reserved	
	3:0	DEPTH3D	0000	Stereo depth 0000: 0% (minimum 3D effect) 0001: 6.67% 1110: 93.3% 1111: 100% (maximum 3D effect)	3D Stereo Enhancement
42 (2Ah)	8:3		0000 00	Reserved	Analogue Outputs
	2	POBCTRL	0	VMID independent current bias control 0 = Disable VMID independent current bias 1 = Enable VMID independent current bias	
	1:0		00	Reserved	
43 (2Bh)	8	BYPL2RMIX	0	Left channel input PGA stage to right output mixer 0 = not selected 1 = selected	Analogue Outputs
	7	BYPR2LMIX	0	Right channel input PGA stage to Left output mixer 0 = not selected 1 = selected	Analogue Outputs
44 (2Ch)	8		0	Reserved	
	7		0	Reserved	
	6		0	Reserved	
	5	RIN2INPPGA	1	Connect RIN pin to right channel input PGA negative terminal. 0=RIN not connected to input PGA 1=RIN connected to right channel input PGA amplifier negative terminal.	Input Signal Path

REGISTER ADDRESS	BIT	LABEL	DEFAULT	DESCRIPTION	REFER TO
	4	RIP2INPPGA	1	Connect RIP pin to right channel input PGA amplifier positive terminal. 0 = RIP not connected to input PGA 1 = right channel input PGA amplifier positive terminal connected to RIP (constant input impedance)	Input Signal Path
	3		0	Reserved	
	2		0	Reserved	
	1	LIN2INPPGA	1	Connect LIN pin to left channel input PGA negative terminal. 0=LIN not connected to input PGA 1=LIN connected to input PGA amplifier negative terminal.	Input Signal Path
	0	LIP2INPPGA	1	Connect LIP pin to left channel input PGA amplifier positive terminal. 0 = LIP not connected to input PGA 1 = input PGA amplifier positive terminal connected to LIP (constant input impedance)	Input Signal Path
45 (2Dh)	8	INPPGAU	N/A	INPPGAVOLL and INPPGAVOLR volume do not update until a 1 is written to INPPGAUPDATE (in reg 45 or 46)	Input Signal Path
	7	INPPGAZCL	0	Left channel input PGA zero cross enable: 0=Update gain when gain register changes 1=Update gain on 1 st zero cross after gain register write.	Input Signal Path
	6	INPPGAMUTEL	0	Mute control for left channel input PGA: 0=Input PGA not muted, normal operation 1=Input PGA muted (and disconnected from the following input BOOST stage).	Input Signal Path
	5:0	INPPGAVOLL	010000	Left channel input PGA volume 000000 = -12dB 000001 = -11.25db . 010000 = 0dB . 111111 = 35.25dB	Input Signal Path
46 (2Eh)	8	INPPGAU	N/A	INPPGAVOLL and INPPGAVOLR volume do not update until a 1 is written to INPPGAUPDATE (in reg 45 or 46)	Input Signal Path
	7	INPPGAZCR	0	Right channel input PGA zero cross enable: 0=Update gain when gain register changes 1=Update gain on 1 st zero cross after gain register write.	Input Signal Path
	6	INPPGAMUTER	0	Mute control for right channel input PGA: 0=Input PGA not muted, normal operation 1=Input PGA muted (and disconnected from the following input BOOST stage).	Input Signal Path
	5:0	INPPGAVOLR	010000	Right channel input PGA volume 000000 = -12dB 000001 = -11.25db . 010000 = 0dB . 111111 = +35.25dB	Input Signal Path

REGISTER ADDRESS	BIT	LABEL	DEFAULT	DESCRIPTION	REFER TO
47 (2Fh)	8	PGABOOSTL	1	Boost enable for left channel input PGA: 0 = PGA output has +0dB gain through input BOOST stage. 1 = PGA output has +20dB gain through input BOOST stage.	Input Signal Path
	7:3		00000	Reserved	
	2:0	AUXL2BOOSTVOL	000	Controls the auxilliary amplifier to the left channel input boost stage: 000=Path disabled (disconnected) 001=-12dB gain through boost stage 010=-9dB gain through boost stage ... 111=+6dB gain through boost stage	Input Signal Path
48 (30h)	8	PGABOOSTR	1	Boost enable for right channel input PGA: 0 = PGA output has +0dB gain through input BOOST stage. 1 = PGA output has +20dB gain through input BOOST stage.	Input Signal Path
	7:3		00000	Reserved	
	2:0	AUXR2BOOSTVOL	000	Controls the auxilliary amplifier to the right channel input boost stage: 000=Path disabled (disconnected) 001=-12dB gain through boost stage 010=-9dB gain through boost stage ... 111=+6dB gain through boost stage	Input Signal Path
49 (31h)	8:7		00	Reserved	
	6	DACL2RMIX	0	Left DAC output to right output mixer 0 = not selected 1 = selected	Analogue Outputs
	5	DACR2LMIX	0	Right DAC output to left output mixer 0 = not selected 1 = selected	Analogue Outputs
	4:3		00	Reserved. Initialise to 0	
	2	TSOPCTRL	0	Thermal Shutdown Output enable 0 = Disabled 1 = Enabled, i.e. all outputs will be disabled if TI set and the device junction temperature is more than 125°C.	Analogue Outputs
	1	TSDEN	1	Thermal Shutdown Enable 0 : thermal shutdown disabled 1 : thermal shutdown enabled	Analogue Outputs
	0	VROI	0	VREF (AVDD/2 or 1.5xAVDD/2) to analogue output resistance 0: approx 1kΩ 1: approx 30 kΩ	Analogue Outputs
50 (32h)	8:6	AUXLMIXVOL	000	Aux left channel input to left mixer volume control: 000 = -15dB 001 = -12dB ... 101 = 0dB 110 = +3dB 111 = +6dB	Analogue Outputs

REGISTER ADDRESS	BIT	LABEL	DEFAULT	DESCRIPTION	REFER TO
	5	AUXL2LMIX	0	Left Auxilliary input to left channel output mixer: 0 = not selected 1 = selected	Analogue Outputs
	4:2	BYPLMIXVOL	000	Volume control for left input PGA to left output mixer: 000 = -15dB 001 = -12dB ... 101 = 0dB 110 = +3dB 111 = +6dB	Analogue Outputs
	1	BYPL2LMIX	0	Left channel input boost output to left output mixer 0 = not selected 1 = selected	Analogue Outputs
	0	DACL2LMIX	1	Left DAC output to left output mixer 0 = not selected 1 = selected	Analogue Outputs
51 (33h)	8:6	AUXRMIXVOL	000	Aux right channel input to right mixer volume control: 000 = -15dB 001 = -12dB ... 101 = 0dB 110 = +3dB 111 = +6dB	Analogue Outputs
	5	AUXR2RMIX	0	Right Auxilliary input to right channel output mixer: 0 = not selected 1 = selected	Analogue Outputs
	4:2	BYPRMIXVOL	000	Volume control for right channel input PAG to right output channel mixer: 000 = -15dB 001 = -12dB ... 101 = 0dB 110 = +3dB 111 = +6dB	Analogue Outputs
	1	BYPR2RMIX	0	Right channel input boost output to right output mixer 0 = not selected 1 = selected	Analogue Outputs
	0	DACR2RMIX	1	Right DAC output to right output mixer 0 = not selected 1 = selected	Analogue Outputs
52 (34h)	8	OUT1VU	N/A	LOUT1 and ROUT1 volumes do not update until a 1 is written to OUT1VU (in reg 52 or 53)	Analogue Outputs
	7	LOUT1ZC	0	Headphone volume zero cross enable: 1 = Change gain on zero cross only 0 = Change gain immediately	Analogue Outputs
	6	LOUT1MUTE	0	Left headphone output mute: 0 = Normal operation 1 = Mute	Analogue Outputs

REGISTER ADDRESS	BIT	LABEL	DEFAULT	DESCRIPTION	REFER TO
	5:0	LOUT1VOL	111001	Left headphone output volume: 000000 = -57dB ... 111001 = 0dB ... 111111 = +6dB	Analogue Outputs
53 (35h)	8	OUT1VU	N/A	LOUT1 and ROUT1 volumes do not update until a 1 is written to OUT1VU (in reg 52 or 53)	Analogue Outputs
	7	ROUT1ZC	0	Headphone volume zero cross enable: 1 = Change gain on zero cross only 0 = Change gain immediately	Analogue Outputs
	6	ROUT1MUTE	0	Right headphone output mute: 0 = Normal operation 1 = Mute	Analogue Outputs
	5:0	ROUT1VOL	111001	Right headphone output volume: 000000 = -57dB ... 111001 = 0dB ... 111111 = +6dB	Analogue Outputs
54 (36h)	8	OUT2VU	N/A	LOUT2 and ROUT2 volumes do not update until a 1 is written to OUT2VU (in reg 54 or 55)	Analogue Outputs
	7	LOUT2ZC	0	Speaker volume zero cross enable: 1 = Change gain on zero cross only 0 = Change gain immediately	Analogue Outputs
	6	LOUT2MUTE	0	Left speaker output mute: 0 = Normal operation 1 = Mute	Analogue Outputs
	5:0	LOUT2VOL	111001	Left speaker output volume: 000000 = -57dB ... 111001 = 0dB ... 111111 = +6dB	Analogue Outputs
55 (37h)	8	OUT2VU	N/A	LOUT2 and ROUT2 volumes do not update until a 1 is written to OUT2VU (in reg 54 or 55)	Analogue Outputs
	7	ROUT2ZC	0	Speaker volume zero cross enable: 1 = Change gain on zero cross only 0 = Change gain immediately	Analogue Outputs
	6	ROUT2MUTE	0	Right speaker output mute: 0 = Normal operation 1 = Mute	Analogue Outputs
	5:0	ROUT2VOL	111001	Right speaker output volume: 000000 = -57dB ... 111001 = 0dB ... 111111 = +6dB	Analogue Outputs
56 (38h)	8:7		00	Reserved	
	6	OUT3MUTE	0	0 = Output stage outputs OUT3 mixer 1 = Output stage muted – drives out VMID. Can be used as VMID buffer in this mode. (Not to be used for Capless HP pseudo GND)	Analogue Outputs
	5:4		00	Reserved	

REGISTER ADDRESS	BIT	LABEL	DEFAULT	DESCRIPTION	REFER TO
	3	OUT4_2OUT3	0	OUT4 mixer output to OUT3 0 = disabled 1 = enabled	Analogue Outputs
	2	BYPL2OUT3	0	Left PGA output to OUT3 0 = disabled 1 = enabled	Analogue Outputs
	1	LMIX2OUT3	0	Left DAC mixer to OUT3 0 = disabled 1 = enabled	Analogue Outputs
	0	LDAC2OUT3	1	Left DAC output to OUT3 0 = disabled 1 = enabled	Analogue Outputs
57 (39h)	8		0	Reserved	
	7	OUT3_2OUT4	0	OUT3 mixer output to OUT4 0 = disabled 1 = enabled	Analogue Outputs
	6	OUT4MUTE	0	0 = Output stage outputs OUT4 mixer 1 = Output stage muted – drives out VMID. Can be used as VMID buffer in this mode. (Not to be used for Capless HP pseudo GND)	Analogue Outputs
	5	HALFSIG	0	0=OUT4 normal output 1=OUT4 attenuated by 6dB	Analogue Outputs
	4	LMIX2OUT4	0	Left DAC mixer to OUT4 0 = disabled 1 = enabled	Analogue Outputs
	3	LDAC2OUT4	0	Left DAC to OUT4 0 = disabled 1 = enabled	Analogue Outputs
	2	BYPR2OUT4	0	Right PGA output to OUT4 0 = disabled 1 = enabled	Analogue Outputs
	1	RMIX2OUT4	0	Right DAC mixer to OUT4 0 = disabled 1 = enabled	Analogue Outputs
	0	RDAC2OUT4	1	Right DAC output to OUT4 0 = disabled 1 = enabled	Analogue Outputs
61 (3Dh)	8		0	Global bias control 0 = normal 1 = 0.5x	Bias Control
	7:0		0000000	Reserved	

DAC DIGITAL FILTER CHARACTERISTICS

PARAMETER	TEST CONDITIONS	MIN	TYP	MAX	UNIT
Passband	+/- 0.035dB	0		0.454fs	
	-6dB		0.5fs		
Passband Ripple				+/-0.035	dB
Stopband		0.546fs			
Stopband Attenuation	f > 0.546fs	-55			dB
Group Delay			29/fs		

Table 43 DAC Digital Filter Characteristics**TERMINOLOGY**

1. Stop Band Attenuation (dB) – the degree to which the frequency spectrum is attenuated (outside audio band)
2. Pass-band Ripple – any variation of the frequency response in the pass-band region

DAC FILTER RESPONSES

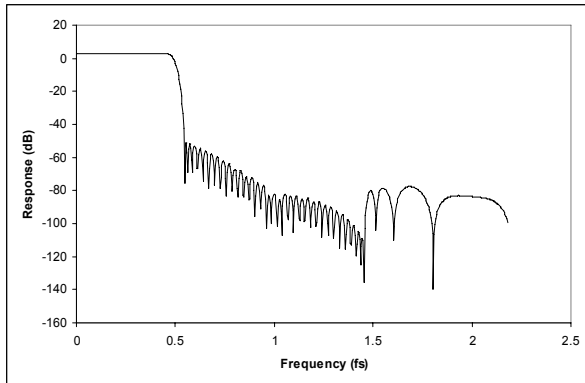

Figure 36 DAC Digital Filter Frequency Response (128xOSR)

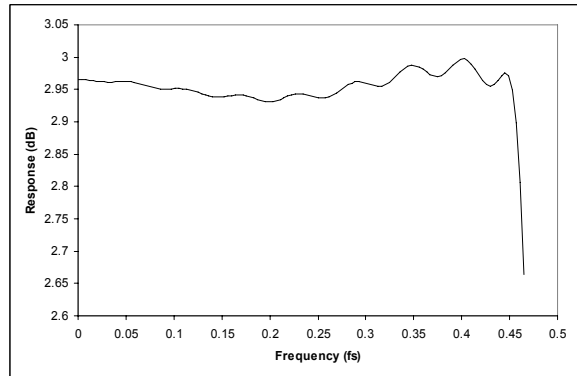

Figure 37 DAC Digital Filter Ripple (128xOSR)

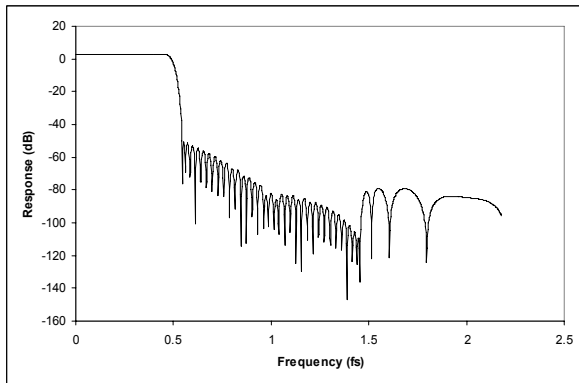

Figure 38 DAC Digital Filter Frequency Response (64xOSR)

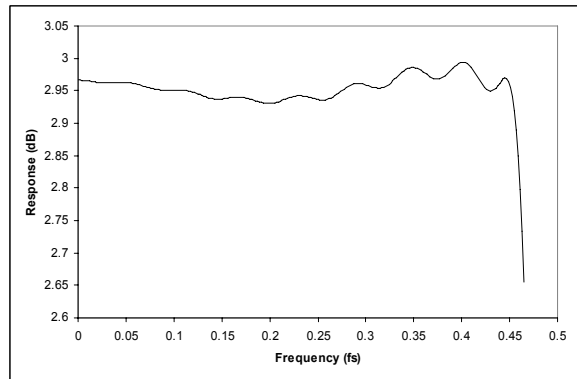

Figure 39 DAC Digital Filter Ripple (64xOSR)

5-BAND EQUALISER

The WM8986 has a 5-band equaliser which can be applied to either the ADC path or the DAC path. The plots from Figure 40 to Figure 53 show the frequency responses of each filter with a sampling frequency of 48kHz, firstly showing the different cut-off/centre frequencies with a gain of $\pm 12\text{dB}$, and secondly a sweep of the gain from -12dB to $+12\text{dB}$ for the lowest cut-off/centre frequency of each filter.

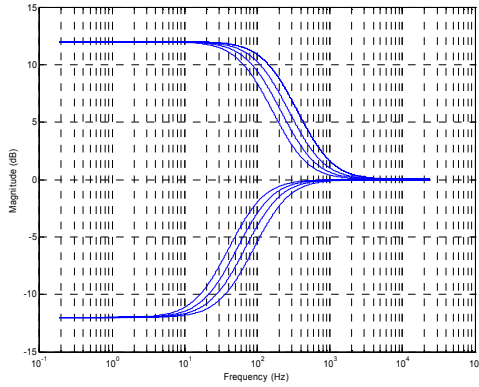

Figure 40 EQ Band 1 Low Frequency Shelf Filter Cut-offs

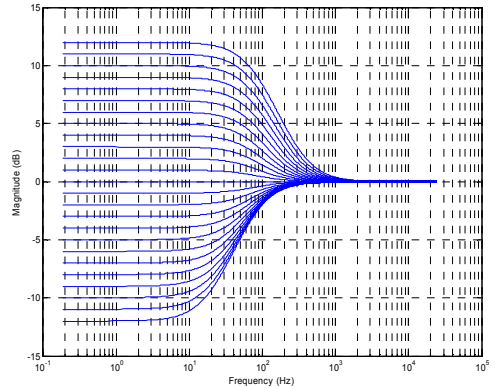

Figure 41 EQ Band 1 Gains for Lowest Cut-off Frequency

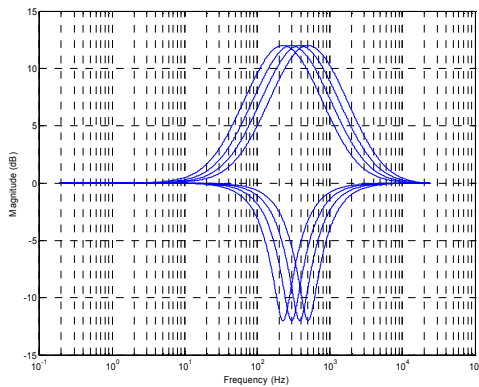

Figure 42 EQ Band 2 – Peak Filter Centre Frequencies, EQ2BW=0

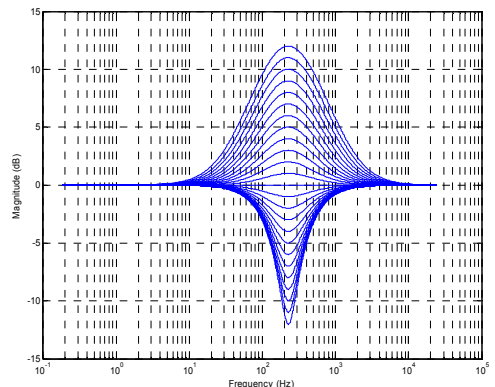

Figure 43 EQ Band 2 – Peak Filter Gains for Lowest Cut-off Frequency, EQ2BW=0

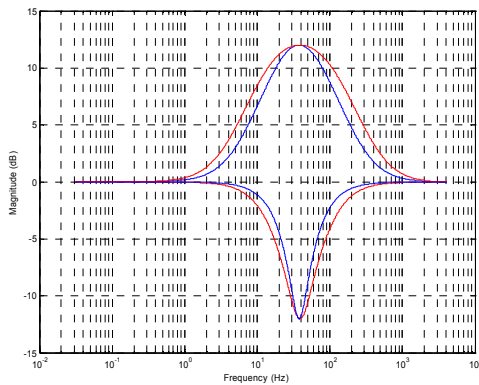

Figure 44 EQ Band 2 – EQ2BW=0, EQ2BW=1

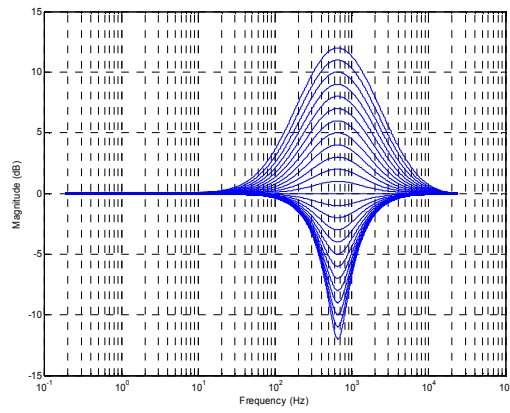
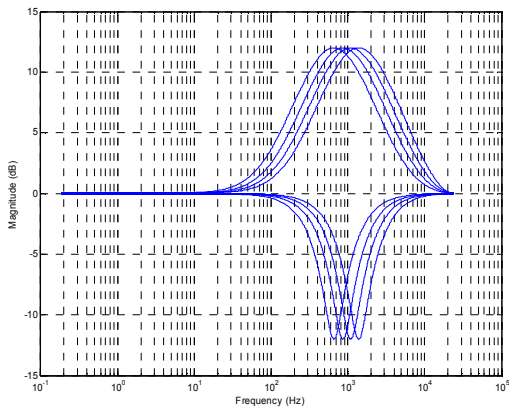

Figure 45 EQ Band 3 – Peak Filter Centre Frequencies, EQ3| Figure 46 EQ Band 3 – Peak Filter Gains for Lowest Cut-off Frequency, EQ3BW=0

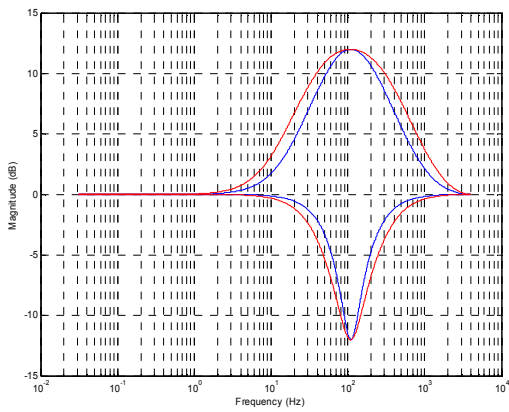

Figure 47 EQ Band 3 – EQ3BW=0, EQ3BW=1

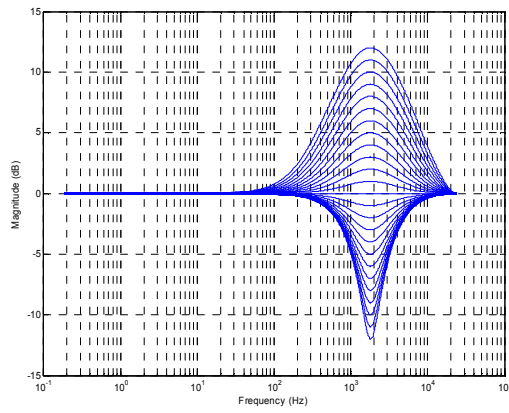
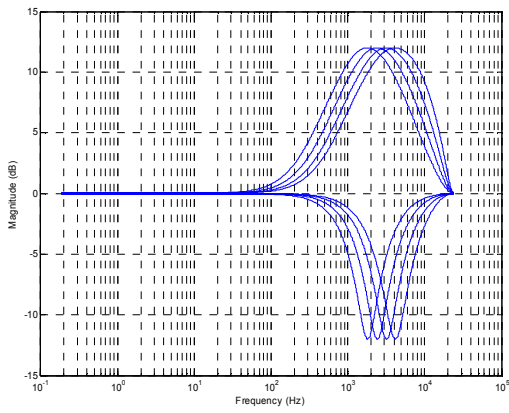

Figure 48 EQ Band 4 – Peak Filter Centre Frequencies, EQ3 Figure 49 EQ Band 4 – Peak Filter Gains for Lowest Cut-off Frequency, EQ4BW=0

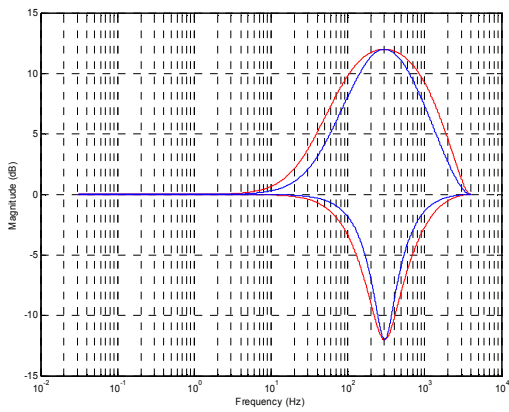

Figure 50 EQ Band 4 – EQ3BW=0, EQ3BW=1

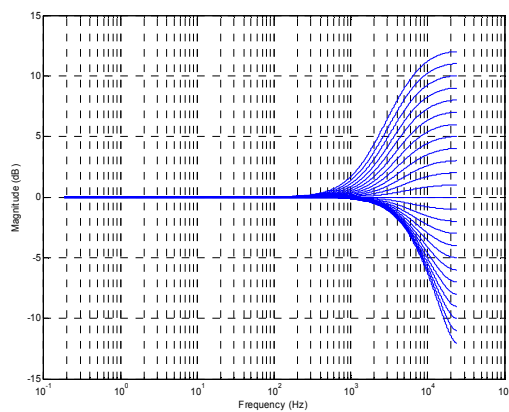
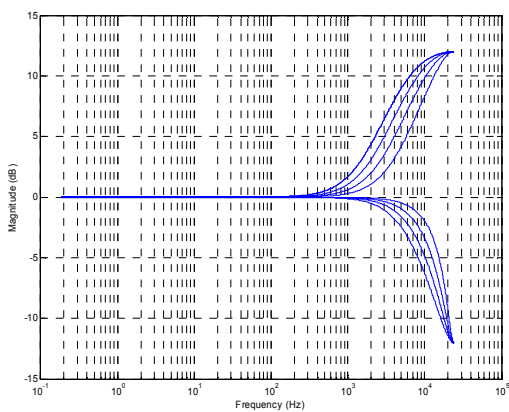

Figure 51 EQ Band 5 High Frequency Shelf Filter Cut-offs Figure 52 EQ Band 5 Gains for Lowest Cut-off Frequency

Figure 53 shows the result of having the gain set on more than one channel simultaneously. The blue traces show each band (lowest cut-off/centre frequency) with $\pm 12\text{dB}$ gain. The red traces show the cumulative effect of all bands with $+12\text{dB}$ gain and all bands -12dB gain, with $\text{EqxBW}=0$ for the peak filters.

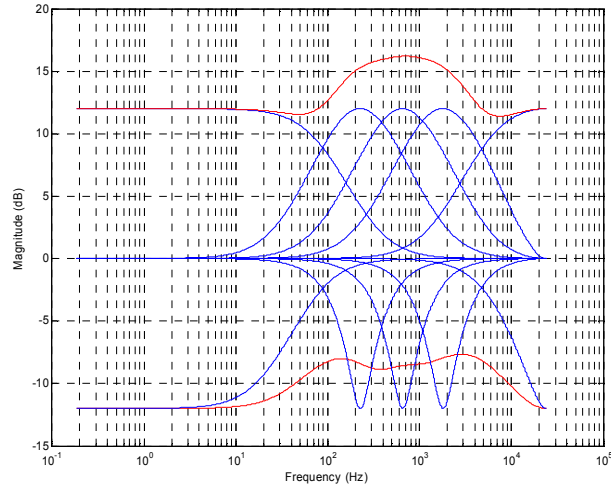

Figure 53 Cumulative Frequency Boost/Cut

APPLICATIONS INFORMATION

RECOMMENDED EXTERNAL COMPONENTS

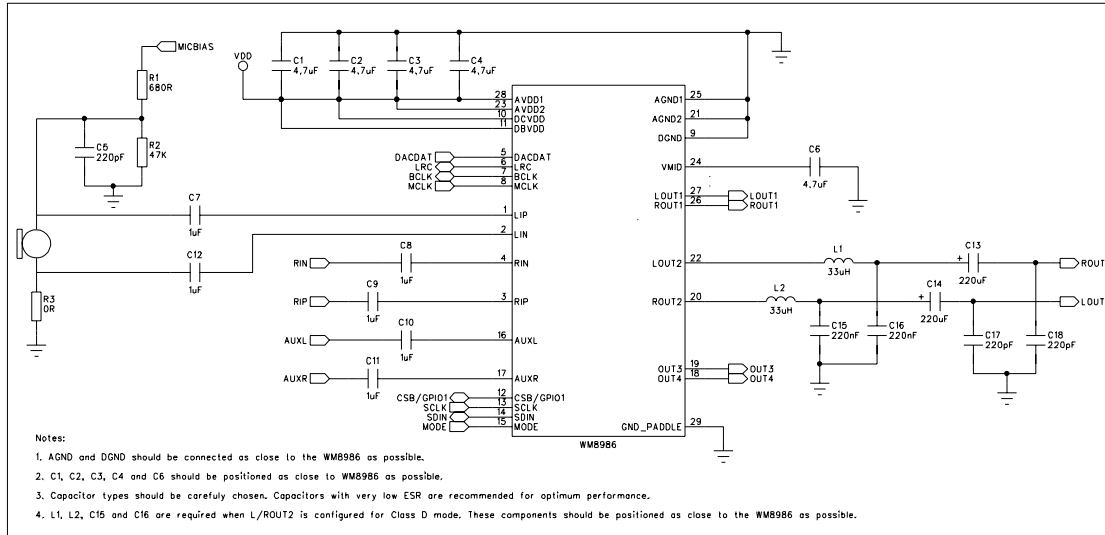
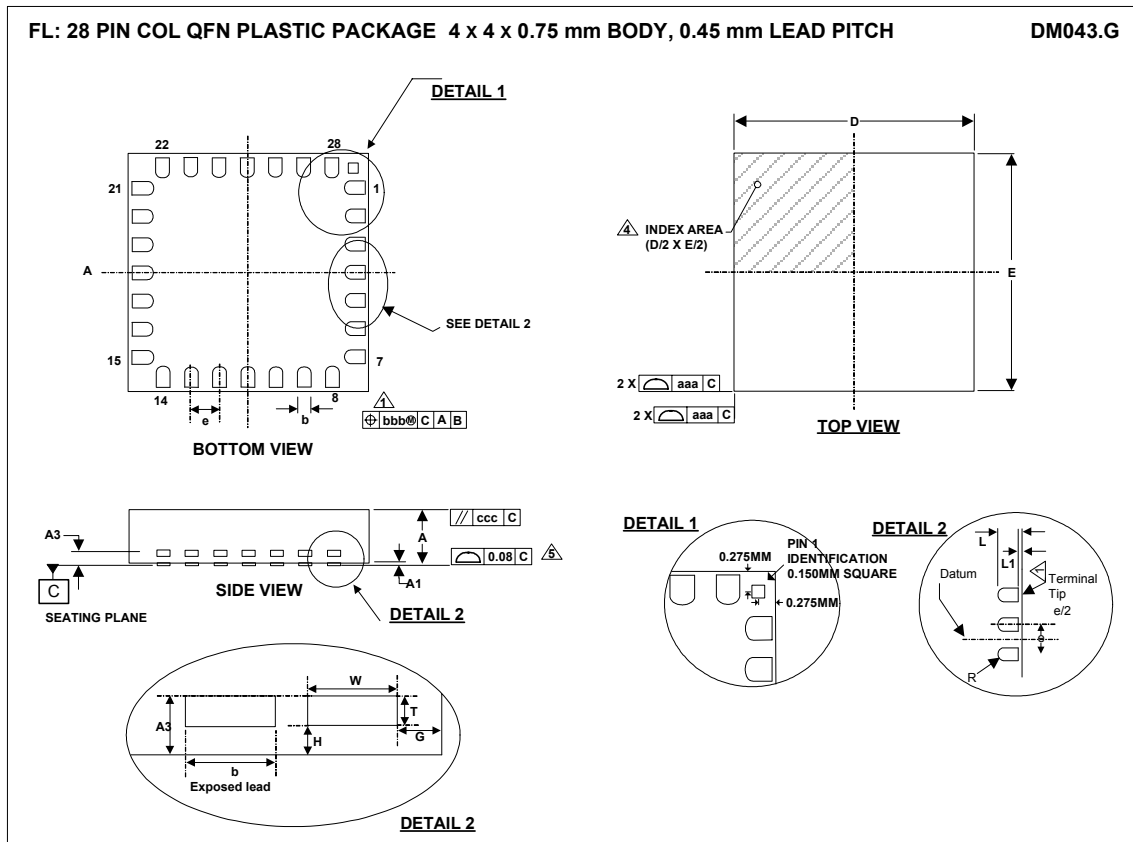

Figure 54 External Component Diagram

Notes:

1. When operating LOUT2 and ROUT2 in class D mode, it is recommended that LC filtering is placed as close to the LOUT2 and ROUT2 pins as possible. Low ESR components should be used for maximum efficiency. It is recommended that a filter, consisting of a 33 μ H inductor and a 220nF capacitor, is used for optimal performance.
2. The addition of ferrite beads to the outputs of LOUT2 and ROUT2 will suppress any potential interference noise produced by the class D switching clocks.

PACKAGE DIAGRAM



Symbols	Dimensions (mm)			
	MIN	NOM	MAX	NOTE
A	0.725	0.75	0.775	
A1	0	0.02	0.05	
A3		0.203 REF		
b	0.18	0.23	0.28	1
D	3.95	4.00	4.05	
E	3.95	4.00	4.05	
e		0.45 BSC		
G		0.535 REF		
H		0.100 REF		
L		0.40 REF		
L1		0.05 REF		5
T		0.100 REF		
W		0.230 REF		
Tolerances of Form and Position				
aaa		0.15		
bbb		0.10		
ccc		0.10		

- NOTES:
- DIMENSION b APPLIES TO METALLIZED TERMINAL AND IS MEASURED BETWEEN 0.15 mm AND 0.30 mm FROM TERMINAL TIP.
 - ALL DIMENSIONS ARE IN MILLIMETRES.
 - COPLANARITY APPLIES TO THE EXPOSED HEAT SINK SLUG AS WELL AS THE TERMINALS.
 - REFER TO APPLICATIONS NOTE WAN_0118 FOR FURTHER INFORMATION REGARDING PCB FOOTPRINTS AND QFN PACKAGE SOLDERING.
 - DEPENDING ON THE METHOD OF LEAD TERMINATION AT THE EDGE OF THE PACKAGE, PULL BACK (L1) MAY BE PRESENT.
 - THIS DRAWING IS SUBJECT TO CHANGE WITHOUT NOTICE.

IMPORTANT NOTICE

Wolfson Microelectronics plc ("Wolfson") products and services are sold subject to Wolfson's terms and conditions of sale, delivery and payment supplied at the time of order acknowledgement.

Wolfson warrants performance of its products to the specifications in effect at the date of shipment. Wolfson reserves the right to make changes to its products and specifications or to discontinue any product or service without notice. Customers should therefore obtain the latest version of relevant information from Wolfson to verify that the information is current.

Testing and other quality control techniques are utilised to the extent Wolfson deems necessary to support its warranty. Specific testing of all parameters of each device is not necessarily performed unless required by law or regulation.

In order to minimise risks associated with customer applications, the customer must use adequate design and operating safeguards to minimise inherent or procedural hazards. Wolfson is not liable for applications assistance or customer product design. The customer is solely responsible for its selection and use of Wolfson products. Wolfson is not liable for such selection or use nor for use of any circuitry other than circuitry entirely embodied in a Wolfson product.

Wolfson's products are not intended for use in life support systems, appliances, nuclear systems or systems where malfunction can reasonably be expected to result in personal injury, death or severe property or environmental damage. Any use of products by the customer for such purposes is at the customer's own risk.

Wolfson does not grant any licence (express or implied) under any patent right, copyright, mask work right or other intellectual property right of Wolfson covering or relating to any combination, machine, or process in which its products or services might be or are used. Any provision or publication of any third party's products or services does not constitute Wolfson's approval, licence, warranty or endorsement thereof. Any third party trade marks contained in this document belong to the respective third party owner.

Reproduction of information from Wolfson datasheets is permissible only if reproduction is without alteration and is accompanied by all associated copyright, proprietary and other notices (including this notice) and conditions. Wolfson is not liable for any unauthorised alteration of such information or for any reliance placed thereon.

Any representations made, warranties given, and/or liabilities accepted by any person which differ from those contained in this datasheet or in Wolfson's standard terms and conditions of sale, delivery and payment are made, given and/or accepted at that person's own risk. Wolfson is not liable for any such representations, warranties or liabilities or for any reliance placed thereon by any person.

ADDRESS:

Wolfson Microelectronics plc
Westfield House
26 Westfield Road
Edinburgh
EH11 2QB
United Kingdom

Tel :: +44 (0)131 272 7000
Fax :: +44 (0)131 272 7001
Email :: sales@wolfsonmicro.com