

## 24-bit, 192kHz Stereo CODEC

### DESCRIPTION

The WM8778 is a high performance, stereo audio CODEC. It is ideal for surround sound processing applications for home hi-fi, DVD-RW and other audio visual equipment.

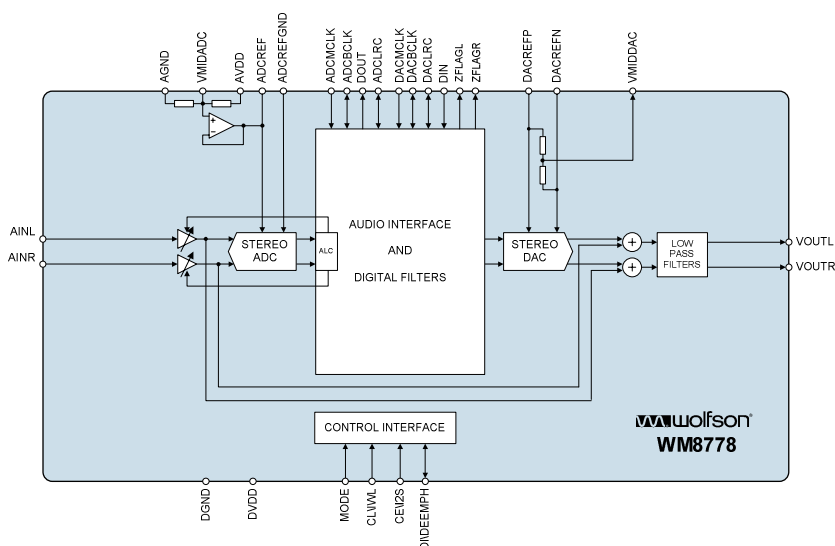
The stereo 24-bit multi-bit sigma delta ADC has programmable gain with automatic level control. Digital audio output word lengths from 16-32 bits and sampling rates from 32kHz to 96kHz are supported.

A stereo multi-bit sigma delta DAC is used with digital audio input word lengths from 16-32 bits and sampling rates from 32kHz to 192kHz. A multiplexor after the DAC allows the selection of either an external analogue input or DAC playback into the line outputs.

The WM8778 supports fully independent sample rates for the ADC and DAC. The audio data interface supports I<sup>2</sup>S, left justified, right justified and DSP formats.

The device is controlled in software via a 2 or 3 wire serial interface which provides access to all features including volume controls, mutes, and de-emphasis facilities. It can also be controlled in hardware which gives access to the most commonly used features. Control interface selection is done via the MODE pin (tri-level). The device is available in a 28-lead SSOP package.

### BLOCK DIAGRAM



### FEATURES

- Audio Performance
  - 108dB SNR ('A' weighted @ 48kHz) DAC
  - 102dB SNR ('A' weighted @ 48kHz) ADC
- DAC Sampling Frequency: 32kHz – 192kHz
- ADC Sampling Frequency: 32kHz – 96kHz
- Stereo ADC input analogue gain adjust from +24dB to –21dB in 0.5dB steps
- ADC digital gain from –21.5dB to –103dB in 0.5dB steps
- Programmable Automatic Level Control (ALC) or Limiter on ADC input.
- Stereo DAC with analogue line outputs.
- 3-Wire SPI Compatible or 2-wire Serial Control Interface
- Hardware Control Mode
- Master or Slave Clocking Mode
- Programmable Audio Data Interface Modes
  - I<sup>2</sup>S, Left, Right Justified or DSP
  - 16/20/24/32 bit Word Lengths
- Analogue Bypass Path Feature
- 2.7V to 5.5V Analogue, 2.7V to 3.6V Digital supply Operation

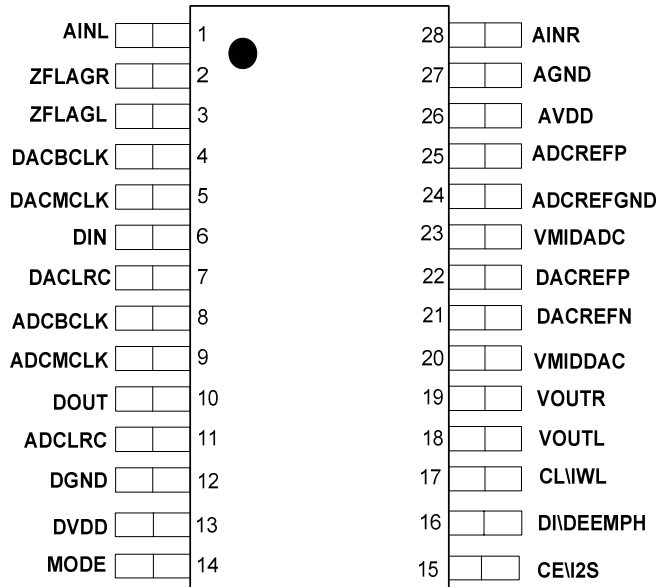
### APPLICATIONS

- Surround Sound AV Processors and Hi-Fi systems
- DVD-RW

## TABLE OF CONTENTS

<b>DESCRIPTION .....</b>	<b>1</b>
<b>FEATURES.....</b>	<b>1</b>
<b>APPLICATIONS .....</b>	<b>1</b>
<b>BLOCK DIAGRAM .....</b>	<b>1</b>
<b>TABLE OF CONTENTS .....</b>	<b>2</b>
<b>PIN CONFIGURATION.....</b>	<b>3</b>
<b>ORDERING INFORMATION .....</b>	<b>3</b>
<b>ABSOLUTE MAXIMUM RATINGS.....</b>	<b>5</b>
<b>ELECTRICAL CHARACTERISTICS .....</b>	<b>6</b>
TERMINOLOGY .....	7
<b>MASTER CLOCK TIMING.....</b>	<b>8</b>
DIGITAL AUDIO INTERFACE – MASTER MODE .....	8
DIGITAL AUDIO INTERFACE – SLAVE MODE .....	9
3-WIRE MPU INTERFACE TIMING .....	11
CONTROL INTERFACE TIMING – 2-WIRE MODE .....	12
<b>INTERNAL POWER ON RESET CIRCUIT .....</b>	<b>13</b>
<b>DEVICE DESCRIPTION .....</b>	<b>15</b>
INTRODUCTION .....	15
AUDIO DATA SAMPLING RATES.....	15
ZERO DETECT .....	17
POWERDOWN MODES .....	17
DIGITAL AUDIO INTERFACE .....	17
CONTROL INTERFACE OPERATION .....	22
CONTROL INTERFACE REGISTERS .....	24
LIMITER / AUTOMATIC LEVEL CONTROL (ALC).....	32
REGISTER MAP .....	38
<b>DIGITAL FILTER CHARACTERISTICS .....</b>	<b>45</b>
DAC FILTER RESPONSES.....	45
ADC FILTER RESPONSES.....	46
ADC HIGH PASS FILTER .....	46
DIGITAL DE-EMPHASIS CHARACTERISTICS.....	47
<b>APPLICATIONS INFORMATION .....</b>	<b>48</b>
RECOMMENDED EXTERNAL COMPONENTS.....	48
<b>PACKAGE DIMENSIONS .....</b>	<b>50</b>
<b>IMPORTANT NOTICE .....</b>	<b>51</b>
ADDRESS: .....	51

## PIN CONFIGURATION



## ORDERING INFORMATION

DEVICE	TEMP. RANGE	PACKAGE	MOISTURE SENSITIVITY LEVEL	PEAK SOLDERING TEMP
WM8778SEDS/V	-25 to +85°C	28-lead SSOP (Pb-free)	MSL3	260°C
WM8778SEDS/RV	-25 to +85°C	28-lead SSOP (Pb-free, tape and reel)	MSL3	260°C

**Note:**

Reel quantity = 2,000

## PIN DESCRIPTION

PIN	NAME	TYPE	DESCRIPTION
1	AINL	Analogue Input	Left channel input
2	ZFLAGR	Digital Output	Right channel zero flag output (external pull-up required)
3	ZFLAGL	Digital Output	Left channel zero flag output (external pull-up required)
4	DACBCLK	Digital Input/Output	DAC audio interface bit clock
5	DACMCLK	Digital Input	Master DAC clock; 256, 384, 512 or 768fs (fs = word clock frequency)
6	DIN	Digital Input	DAC data input
7	DACLRC	Digital Input/Output	DAC left/right word clock
8	ADCBCLK	Digital Input/Output	ADC audio interface bit clock
9	ADCMCLK	Digital Input	Master ADC clock; 256, 384, 512 or 768fs (fs = word clock frequency)
10	DOUT	Digital Output	ADC data output
11	ADCLRC	Digital Input/Output	ADC left/right word clock
12	DGND	Supply	Digital negative supply
13	DVDD	Supply	Digital positive supply
14	MODE	Digital Input	Control interface mode select, tri-level
15	CE 2S	Digital Input	Serial interface Latch signal
16	DI DEMPH	Digital Input/Output	Serial interface data
17	CL WL	Digital Input	Serial interface clock
18	VOU TL	Analogue Output	DAC channel left output
19	VOU TR	Analogue Output	DAC channel right output
20	VMIDDAC	Analogue Output	DAC midrail decoupling pin ; 10uF external decoupling
21	DACREFN	Analogue Input	DAC negative reference input
22	DACREFP	Analogue Input	DAC positive reference input
23	VMIDADC	Analogue Output	ADC midrail divider decoupling pin; 10uF external decoupling
24	ADCREFGND	Analogue Output	ADC reference buffer decoupling pin; 10uF external decoupling
25	ADCREFP	Analogue Output	ADC positive reference decoupling pin; 10uF external decoupling
26	AVDD	Supply	Analogue positive supply
27	AGND	Supply	Analogue negative supply and substrate connection
28	AINR	Analogue Input	Right channel input

**Note** : Digital input pins have Schmitt trigger input buffers.

## ABSOLUTE MAXIMUM RATINGS

Absolute Maximum Ratings are stress ratings only. Permanent damage to the device may be caused by continuously operating at or beyond these limits. Device functional operating limits and guaranteed performance specifications are given under Electrical Characteristics at the test conditions specified.



ESD Sensitive Device. This device is manufactured on a CMOS process. It is therefore generically susceptible to damage from excessive static voltages. Proper ESD precautions must be taken during handling and storage of this device.

Wolfson tests its package types according to IPC/JEDEC J-STD-020B for Moisture Sensitivity to determine acceptable storage conditions prior to surface mount assembly. These levels are:

MSL1 = unlimited floor life at <30°C / 85% Relative Humidity. Not normally stored in moisture barrier bag.

MSL2 = out of bag storage for 1 year at <30°C / 60% Relative Humidity. Supplied in moisture barrier bag.

MSL3 = out of bag storage for 168 hours at <30°C / 60% Relative Humidity. Supplied in moisture barrier bag.

The Moisture Sensitivity Level for each package type is specified in Ordering Information.

CONDITION	MIN	MAX
Digital supply voltage	-0.3V	+3.63V
Analogue supply voltage	-0.3V	+7V
Voltage range digital inputs (MCLK, DIN, ADCLRC, DACLRC, ADCBCLK, DACBCLK, DI, CL, CE and MODE)	DGND -0.3V	DVDD + 0.3V
Voltage range analogue inputs	AGND -0.3V	AVDD +0.3V
Master Clock Frequency		37MHz
Operating temperature range, T <sub>A</sub>	-25°C	+85°C
Storage temperature	-65°C	+150°C

### Notes:

1. Analogue and digital grounds must always be within 0.3V of each other.

**RECOMMENDED OPERATING CONDITIONS**

PARAMETER	SYMBOL	TEST CONDITIONS	MIN	TYP	MAX	UNIT
Digital supply range	DVDD		2.7		3.6	V
Analogue supply range	AVDD, DACREFP		2.7		5.5	V
Ground	AGND, DGND, DACREFN, ADCREFGND			0		V
Difference DGND to AGND			-0.3	0	+0.3	V

**Note:** Digital supply DVDD must never be more than 0.3V greater than AVDD.

**ELECTRICAL CHARACTERISTICS****Test Conditions**

AVDD = 5V, DVDD = 3.3V, AGND = 0V, DGND = 0V, T<sub>A</sub> = +25°C, fs = 48kHz, MCLK = 256fs unless otherwise stated.

PARAMETER	SYMBOL	TEST CONDITIONS	MIN	TYP	MAX	UNIT
<b>Digital Logic Levels (TTL Levels)</b>						
Input LOW level	V <sub>IL</sub>				0.8	V
Input HIGH level	V <sub>IH</sub>		2.0			V
Output LOW	V <sub>OL</sub>	I <sub>OL</sub> =1mA			0.1 x DVDD	V
Output HIGH	V <sub>OH</sub>	I <sub>OH</sub> =1mA	0.9 x DVDD			V
<b>Analogue Reference Levels</b>						
Reference voltage	V <sub>VMID</sub>			AVDD/2		V
Potential divider resistance	R <sub>VMID</sub>			50k		Ω
<b>DAC Performance (Load = 10k Ω, 50pF)</b>						
0dBfs Full scale output voltage				1.0 x AVDD/5		V <sub>rms</sub>
SNR (Note 1,2)		A-weighted, @ fs = 48kHz	102	108		dB
SNR (Note 1,2)		A-weighted @ fs = 96kHz		108		dB
Dynamic Range (Note 2)	DNR	A-weighted, -60dB full scale input	102	108		dB
Total Harmonic Distortion (THD)		1kHz, 0dBfs		-97	-90	dB
DAC channel separation				100		dB
Power Supply Rejection Ratio	PSRR	1kHz 100mVpp		50		dB
		20Hz to 20kHz 100mVpp		45		dB
<b>ADC Performance</b>						
Input Signal Level (0dB)				1.0 x AVDD/5		V <sub>rms</sub>
SNR (Note 1,2)		A-weighted, 0dB gain @ fs = 48kHz	97	102		dB
SNR (Note 1,2)		A-weighted, 0dB gain @ fs = 96kHz 64 x OSR		99		dB
Dynamic Range (note 2)		A-weighted, -60dB full scale input		102		dB
Total Harmonic Distortion (THD)		1kHz, 0dBfs		-92		dB
		1kHz, -1dBfs		-95	-85	dB
ADC Channel Separation		1kHz Input		90		dB

**Test Conditions**

AVDD = 5V, DVDD = 3.3V, AGND = 0V, DGND = 0V, T<sub>A</sub> = +25°C, fs = 48kHz, MCLK = 256fs unless otherwise stated.

Programmable Gain Step Size			0.25	0.5	0.75	dB
Programmable Gain Range (Analogue)		1kHz Input	-21		+24	dB
Programmable Gain Range (Digital)		1kHz Input	-103		-21.5	dB
Analogue Mute Attenuation (Note 6)		1kHz Input, 0dB gain		76		dB
Power Supply Rejection Ratio	PSRR	1kHz 100mVpp		50		dB
		20Hz to 20kHz 100mVpp		45		dB
<b>Analogue input (AIN) to Analogue output (VOUT) (Load=10k Ω, 50pF, gain = 0dB) Bypass Mode</b>						
0dB Full scale output voltage				1.0 x AVDD/5		Vrms
SNR (Note 1)			99	103		dB
THD		1kHz, 0dB		-93		dB
		1kHz, -3dB		-95		dB
Power Supply Rejection Ratio	PSRR	1kHz 100mVpp		50		dB
		20Hz to 20kHz 100mVpp		45		dB
Mute Attenuation		1kHz, 0dB		100		dB
<b>Supply Current</b>						
Analogue supply current		AVDD = 5V		48		mA
Digital supply current		DVDD = 3.3V		8		mA

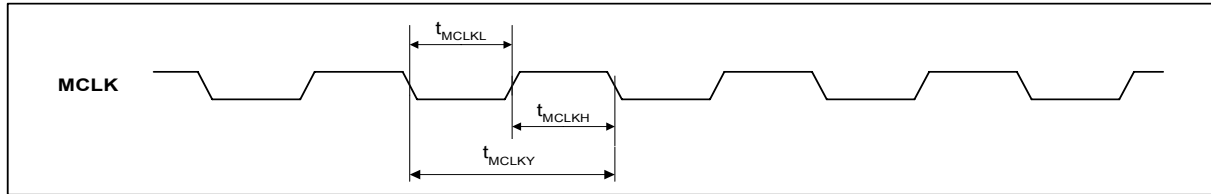
**Notes:**

- Ratio of output level with 1kHz full scale input, to the output level with all zeros into the digital input, measured 'A' weighted.
- All performance measurements done with 20kHz low pass filter, and where noted an A-weight filter. Failure to use such a filter will result in higher THD+N and lower SNR and Dynamic Range readings than are found in the Electrical Characteristics. The low pass filter removes out of band noise; although it is not audible it may affect dynamic specification values.
- VMID decoupled with 10uF and 0.1uF capacitors (smaller values may result in reduced performance).
- Harmonic distortion on the headphone output decreases with output power.
- All performance measurement done using certain timings conditions (Please refer to section 'Digital Audio Interface').
- A full digital MUTE can be achieved if the ADC gain (LAG/RAG) is set to minimum.

**TERMINOLOGY**

- Signal-to-noise ratio (dB) - SNR is a measure of the difference in level between the full scale output and the output with no signal applied. (No Auto-zero or Automute function is employed in achieving these results).
- Dynamic range (dB) - DNR is a measure of the difference between the highest and lowest portions of a signal. Normally a THD+N measurement at 60dB below full scale. The measured signal is then corrected by adding the 60dB to it. (e.g. THD+N @ -60dB= -32dB, DR= 92dB).
- THD+N (dB) - THD+N is a ratio, of the rms values, of (Noise + Distortion)/Signal.
- Stop band attenuation (dB) - Is the degree to which the frequency spectrum is attenuated (outside audio band).
- Channel Separation (dB) - Also known as Cross-Talk. This is a measure of the amount one channel is isolated from the other. Normally measured by sending a full scale signal down one channel and measuring the other.
- Pass-Band Ripple - Any variation of the frequency response in the pass-band region.

**MASTER CLOCK TIMING**



**Figure 1 Master Clock Timing Requirements**

**Test Conditions**

AVDD = 5V, DVDD = 3.3V, AGND = 0V, DGND = 0V, T<sub>A</sub> = +25°C, fs = 48kHz, ADC/DACMCLK = 256fs unless otherwise stated.

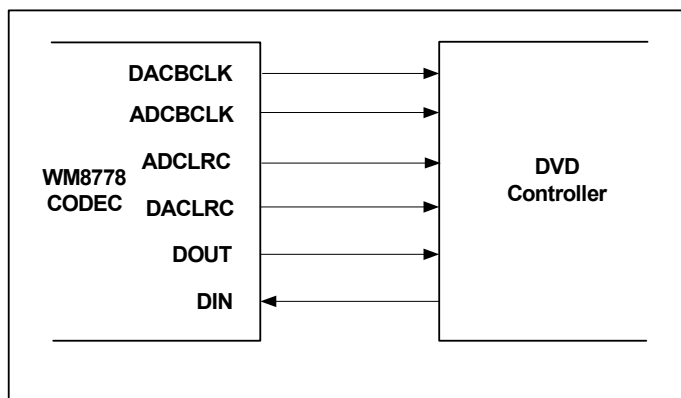
PARAMETER	SYMBOL	TEST CONDITIONS	MIN	TYP	MAX	UNIT
<b>System Clock Timing Information</b>						
ADC/DACMCLK System clock pulse width high	$t_{MCLKH}$		11			ns
ADC/DACMCLK System clock pulse width low	$t_{MCLKL}$		11			ns
ADC/DACMCLK System clock cycle time	$t_{MCLKY}$		28		1000	ns
ADC/DACMCLK Duty cycle			40:60		60:40	
Power-saving mode activated		After MCLK stopped	2		10	µs
Normal mode resumed		After MCLK re-started	0.5		1	MCLK cycle

**Table 1 Master Clock Timing Requirements**

**Note:**

If MCLK period is longer than maximum specified above, power-saving mode is entered and DACs are powered down with internal digital audio filters being reset. In this power-saving mode, all registers will retain their values and can be accessed in the normal manner through the control interface. Once MCLK is restored, the DACs are automatically powered up, but a write to the volume update register bit is required to restore the correct volume settings.

**DIGITAL AUDIO INTERFACE – MASTER MODE**



**Figure 2 Audio Interface - Master Mode**



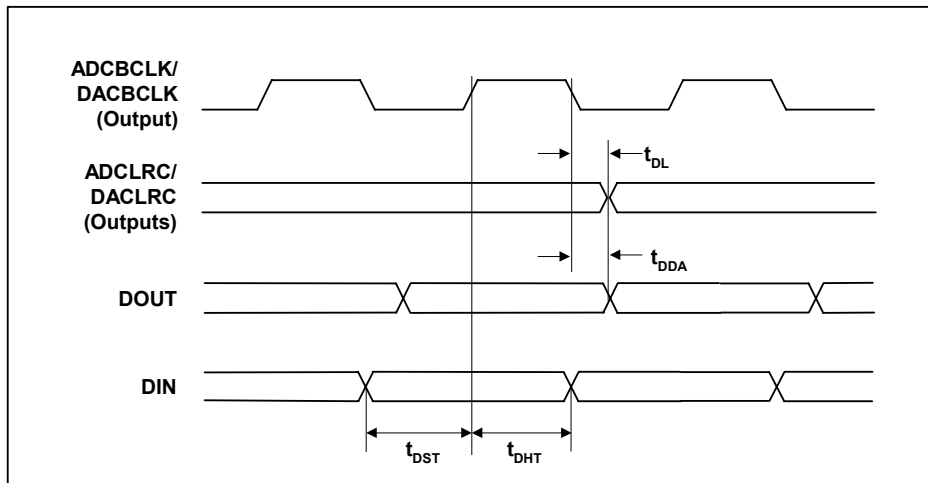


Figure 3 Digital Audio Data Timing – Master Mode

**Test Conditions**

AVDD = 5V, DVDD = 3.3V, AGND = 0V, DGND = 0V, T<sub>A</sub> = +25°C, Master Mode, fs = 48kHz, ADC/DACMCLK = 256fs unless otherwise stated.

PARAMETER	SYMBOL	TEST CONDITIONS	MIN	TYP	MAX	UNIT
<b>Audio Data Input Timing Information</b>						
ADC/DACLRC propagation delay from ADC/DACBCLK falling edge	t <sub>DL</sub>		0		10	ns
DOUT propagation delay from ADCBCLK falling edge	t <sub>DDA</sub>		0		10	ns
DIN setup time to DACBCLK rising edge	t <sub>DST</sub>		10			ns
DIN hold time from DACBCLK rising edge	t <sub>DHT</sub>		10			ns

Table 2 Digital Audio Data Timing – Master Mode

**DIGITAL AUDIO INTERFACE – SLAVE MODE**

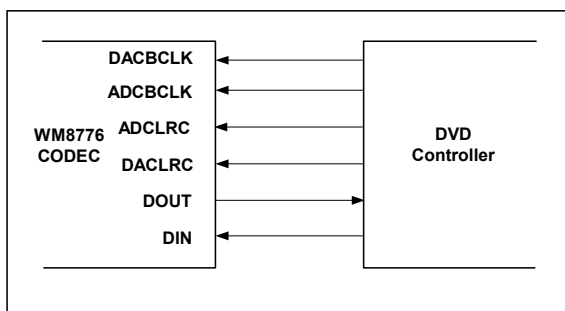


Figure 4 Audio Interface – Slave Mode

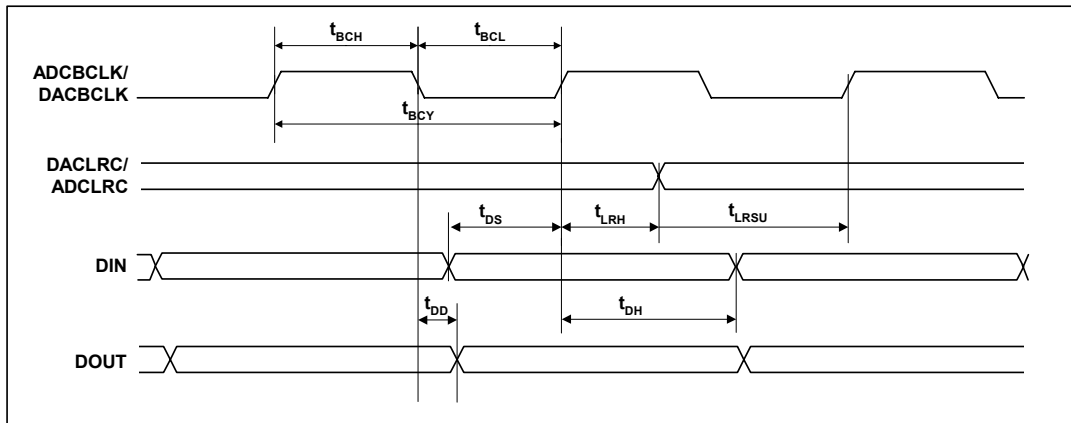


Figure 5 Digital Audio Data Timing – Slave Mode

**Test Conditions**

AVDD = 5V, DVDD = 3.3V, AGND = 0V, DGND = 0V, T<sub>A</sub> = +25°C, Slave Mode, fs = 48kHz, ADC/DACMCLK = 256fs unless otherwise stated.

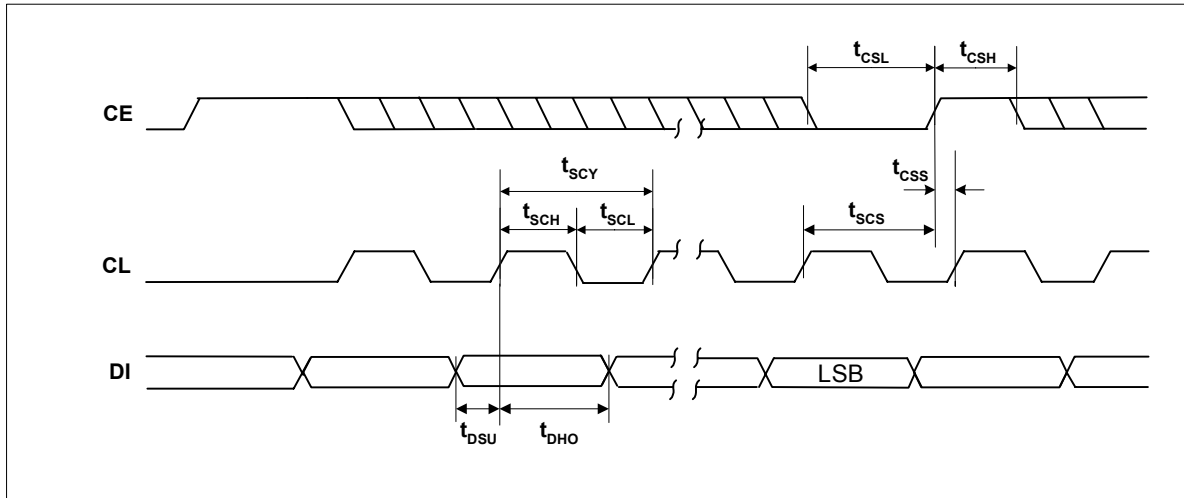
PARAMETER	SYMBOL	TEST CONDITIONS	MIN	TYP	MAX	UNIT
<b>Audio Data Input Timing Information</b>						
ADC/DACBCLK cycle time	t <sub>BCY</sub>		50			ns
ADC/DACBCLK pulse width high	t <sub>BCH</sub>		20			ns
ADC/DACBCLK pulse width low	t <sub>BCL</sub>		20			ns
DACLRC/ADCLRC set-up time to ADC/DACBCLK rising edge	t <sub>LRSU</sub>		10			ns
DACLRC/ADCLRC hold time from ADC/DACBCLK rising edge	t <sub>LRH</sub>		10			ns
DIN set-up time to DACBCLK rising edge	t <sub>DS</sub>		10			ns
DIN hold time from DACBCLK rising edge	t <sub>DH</sub>		10			ns
DOUT propagation delay from ADCBCLK falling edge	t <sub>DD</sub>		0		10	ns

Table 3 Digital Audio Data Timing – Slave Mode

**Note:**

ADCLRC and DACLRC should be synchronous with MCLK, although the WM8778 interface is tolerant of phase variations or jitter on these signals.

**3-WIRE MPU INTERFACE TIMING**

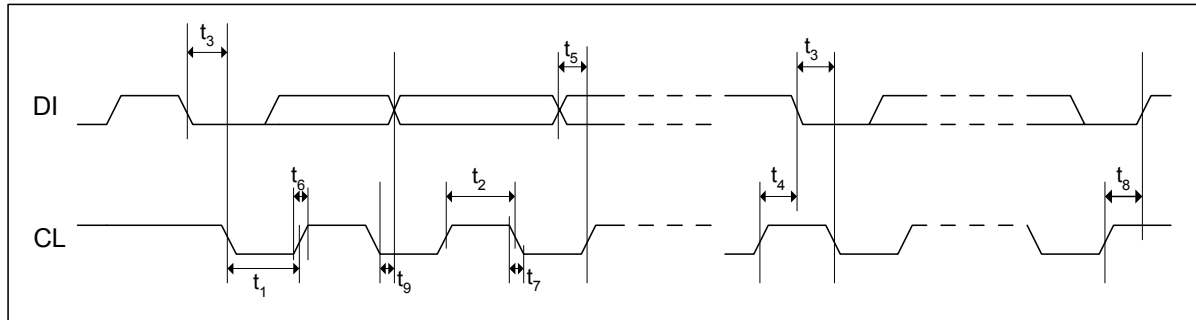


**Figure 6 SPI Compatible (3-wire) Control Interface Input Timing (MODE=1)**

<b>Test Conditions</b>					
AVDD = 5V, DVDD = 3.3V, AGND, DGND = 0V, T <sub>A</sub> = +25°C, fs = 48kHz, MCLK = 256fs unless otherwise stated					
PARAMETER	SYMBOL	MIN	TYP	MAX	UNIT
CL rising edge to CE rising edge	t <sub>SCS</sub>	60			ns
CL pulse cycle time	t <sub>SCY</sub>	80			ns
CL pulse width low	t <sub>SCL</sub>	30			ns
CL pulse width high	t <sub>SCH</sub>	30			ns
DI to CL set-up time	t <sub>DSU</sub>	20			ns
CL to DI hold time	t <sub>DHO</sub>	20			ns
CE pulse width low	t <sub>CSL</sub>	20			ns
CE pulse width high	t <sub>CSH</sub>	20			ns
CE rising to CL rising	t <sub>CSS</sub>	20			ns

**Table 4 3-wire SPI Compatible Control Interface Input Timing Information**

**CONTROL INTERFACE TIMING – 2-WIRE MODE**



**Figure 7 Control Interface Timing – 2-Wire Serial Control Mode (MODE=0)**

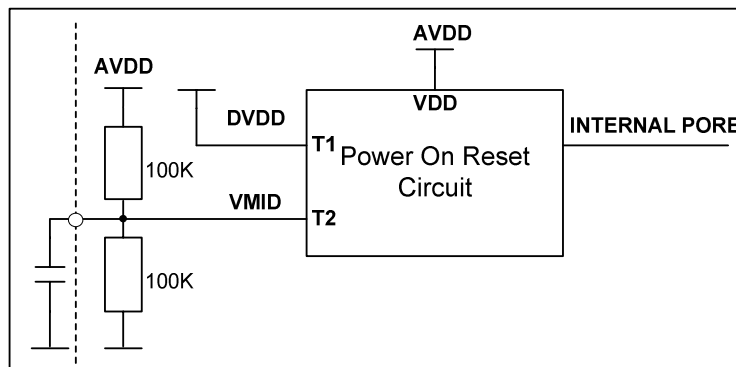
**Test Conditions**

AVDD = 5V, DVDD = 3.3V, AGND, DGND = 0V,  $T_A = +25^\circ\text{C}$ ,  $f_s = 48\text{kHz}$ , MCLK = 256fs unless otherwise stated

PARAMETER	SYMBOL	MIN	TYP	MAX	UNIT
<b>Program Register Input Information</b>					
CL Frequency		0		526	kHz
CL Low Pulse-Width	$t_1$	1.3			us
CL High Pulse-Width	$t_2$	600			ns
Hold Time (Start Condition)	$t_3$	600			ns
Setup Time (Start Condition)	$t_4$	600			ns
Data Setup Time	$t_5$	100			ns
DI, CL Rise Time	$t_6$			300	ns
DI, CL Fall Time	$t_7$			300	ns
Setup Time (Stop Condition)	$t_8$	600			ns
Data Hold Time	$t_9$			900	ns
Pulse width of spikes that will be suppressed	$t_{ps}$	0		5	ns

**Table 5 2-wire Control Interface Timing Information**

### INTERNAL POWER ON RESET CIRCUIT



**Figure 8 Internal Power on Reset Circuit Schematic**

The WM8778 includes an internal Power on Reset Circuit which is used reset the digital logic into a default state after power up.

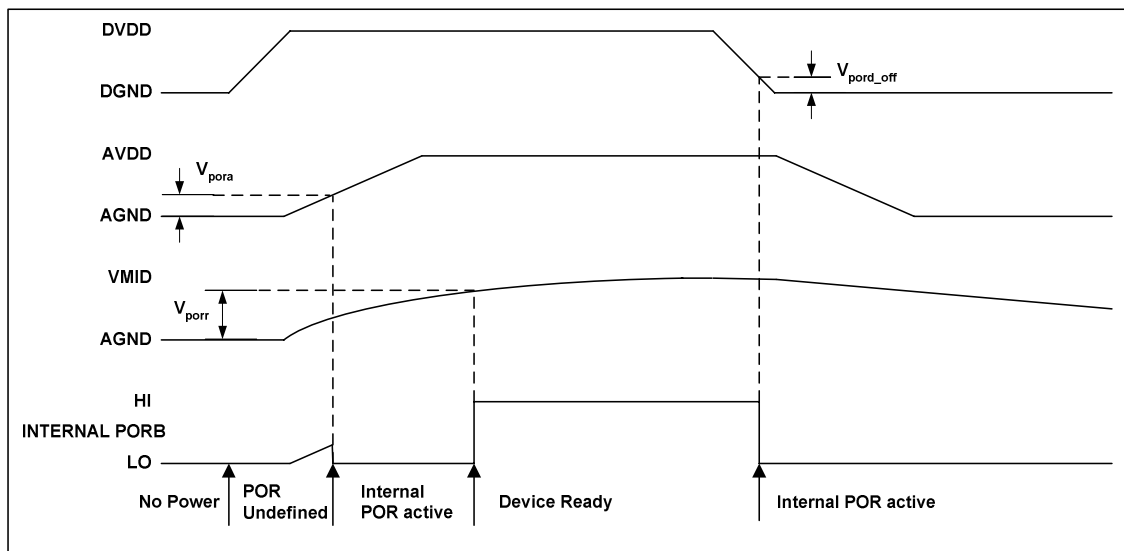
Figure 8 shows a schematic of the internal POR circuit. The POR circuit is powered from AVDD. The circuit monitors DVDD and VMID and asserts PORB low if DVDD or VMID are below the minimum threshold  $V_{por\_off}$ .

On power up, the POR circuit requires AVDD to be present to operate. PORB is asserted low until AVDD and DVDD and VMID are established. When AVDD, DVDD, and VMID have been established, PORB is released high, all registers are in their default state and writes to the digital interface may take place.

On power down, PORB is asserted low whenever DVDD or VMID drop below the minimum threshold  $V_{por\_off}$ .

If AVDD is removed at any time, the internal Power on Reset circuit is powered down and PORB will follow AVDD.

In most applications the time required for the device to release PORB high will be determined by the charge time of the VMID node.



**Figure 9 Typical Power up Sequence where DVDD is Powered before AVDD**

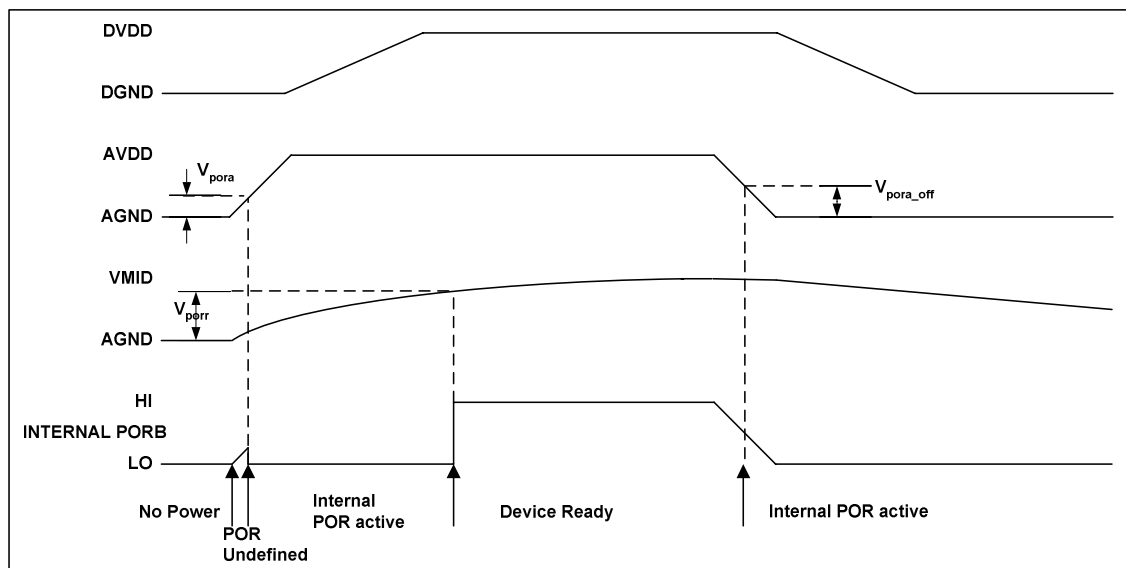


Figure 10 Typical Power up Sequence where AVDD is Powered before DVDD

#### Typical POR Operation (typical values, not tested)

SYMBOL	MIN	TYP	MAX	UNIT
$V_{pora}$	0.5	0.7	1.0	V
$V_{porr}$	0.5	0.7	1.1	V
$V_{pora\_off}$	1.0	1.4	2.0	V
$V_{pord\_off}$	0.6	0.8	1.0	V

In a real application the designer is unlikely to have control of the relative power up sequence of AVDD and DVDD. Using the POR circuit to monitor VMID ensures a reasonable delay between applying power to the device and Device Ready.

Figure 9 and Figure 10 show typical power up scenarios in a real system. Both AVDD and DVDD must be established and VMID must have reached the threshold  $V_{porr}$  before the device is ready and can be written to. Any writes to the device before Device Ready will be ignored.

Figure 9 shows DVDD powering up before AVDD. Figure 10 shows AVDD powering up before DVDD. In both cases, the time from applying power to Device Ready is dominated by the charge time of VMID.

A 10uF cap is recommended for decoupling on VMID. The charge time for VMID will dominate the time required for the device to become ready after power is applied. The time required for VMID to reach the threshold is a function of the VMID resistor string and the decoupling capacitor. The Resistor string has an typical equivalent resistance of 50k $\Omega$  (+/-20%). Assuming a 10uF capacitor, the time required for VMID to reach threshold of 1V is approx 110ms.

## DEVICE DESCRIPTION

### INTRODUCTION

WM8778 is a complete 2-channel DAC, 2-channel ADC audio CODEC, including digital interpolation and decimation filters, multi-bit sigma delta stereo ADC, and switched capacitor multi-bit sigma delta DACs with output smoothing filters. It is available in a single package and controlled by a 3 or 2-wire serial interface or in a hardware mode.

An analogue bypass path option is available, to allow stereo analogue signals from the stereo inputs to be sent to the stereo outputs. This allows a purely analogue input to analogue output high quality signal path to be implemented if required.

The DAC and ADC have separate left/right clocks, bit clocks, master clocks and data I/Os. The Audio Interface may be configured to operate in either master or slave mode. In Slave mode ADCLRC, DACLRC, ADCBCLK and DACBCLK are all inputs. In Master mode ADCLRC, DACLRC, ADCBCLK and DACBCLK are outputs.

The ADC has an analogue input PGA and a digital gain control, accessed by one register write. The input PGA allows input signals to be gained up to +24dB and attenuated down to -21dB in 0.5dB steps. The digital gain control allows attenuation from -21.5dB to -103dB in 0.5dB steps. This allows the user maximum flexibility in the use of the ADC.

The DAC has its own digital volume control, which is adjustable between 0dB and -127.5dB in 0.5dB steps. In addition a zero cross detect circuit is provided for digital volume controls. The digital volume control detects a transition through the zero point before updating the volume. This minimises audible clicks and 'zipper' noise as the gain values change.

The DAC output incorporates an input selector and mixer allowing a signal to be either switched into the signal path in place of the DAC signal or mixed with the DAC signal before the analogue outputs.

Control of internal functionality of the device can be by 3-wire SPI compatible or 2-wire serial control interface, or hardware mode, selected by the MODE pin. Both interfaces may be asynchronous to the audio data interface as control data will be re-synchronised to the audio processing internally.

Operation using system clock of 128fs, 192fs, 256fs, 384fs, 512fs or 768fs is provided. In Slave mode selection between clock rates is automatically controlled. In master mode the master clock to sample rate ratio is set by control bits ADCRATE and DACRATE. ADC and DAC may run at different rates. Master clock sample rates (fs) from less than 32kHz up to 192kHz are allowed, provided the appropriate system clock is input.

The audio data interface supports right, left and I<sup>2</sup>S interface formats along with a highly flexible DSP serial port interface.

### AUDIO DATA SAMPLING RATES

In a typical digital audio system there is only one central clock source producing a reference clock to which all audio data processing is synchronised. This clock is often referred to as the audio system's Master Clock. The WM8778 uses separate master clocks for the ADC and DAC. The external master system clocks can be applied directly through the ADCMCLK and DACMCLK input pins with no software configuration necessary. In a system where there are a number of possible sources for the reference clock it is recommended that the clock source with the lowest jitter be used to optimise the performance of the ADC and DAC.

The master clock for WM8778 supports DAC audio sampling rates from 128fs to 768fs and ADC sampling rates from 256fs to 512fs, where fs is the audio sampling frequency (DACLRC or ADCLRC) typically 32kHz, 44.1kHz, 48kHz or 96kHz. The master clock is used to operate the digital filters and the noise shaping circuits.

In Slave mode the WM8778 has a master detection circuit that automatically determines the relationship between the master clock frequency and the sampling rate (to within +/- 32 system clocks). If there is a greater than 32 clocks error the interface is disabled and maintains the output level at the last sample. The master clock must be synchronised with ADCLRC/DACLRC, although the WM8778 is tolerant of phase variations or jitter on this clock. Table 6 shows the typical master clock frequency inputs for the WM8778.

The signal processing for the WM8778 typically operates at an oversampling rate of 128fs for both ADC and DAC. The exception to this for the DAC is for operation with a 128/192fs system clock, e.g. for 192kHz operation where the oversampling rate is 64fs. For ADC operation at 96kHz it is recommended that the user set the ADCOSR bit. This changes the ADC signal processing oversample rate to 64fs.

SAMPLING RATE (DACLRC/ ADCLRC)	System Clock Frequency (MHz)					
	128fs	192fs	256fs	384fs	512fs	768fs
	DAC ONLY					
32kHz	4.096	6.144	8.192	12.288	16.384	24.576
44.1kHz	5.6448	8.467	11.2896	16.9340	22.5792	33.8688
48kHz	6.144	9.216	12.288	18.432	24.576	36.864
96kHz	12.288	18.432	24.576	36.864	Unavailable	Unavailable
192kHz	24.576	36.864	Unavailable	Unavailable	Unavailable	Unavailable

**Table 6 System Clock Frequencies Versus Sampling Rate**

In Master mode DACBCLK, ADCBCLK, DACLRC and ADCLRC are generated by the WM8778. The frequencies of ADCLRC and DACLRC are set by setting the required ratio of DACMCLK to DACLRC and ADCMCLK to ADCLRC using the DACRATE and ADCRATE control bits (Table 7).

ADCRATE[2:0]/ DACRATE[2:0]	ADCMCLK/DACMCLK: ADCLRC/DACLRC RATIO
000	128fs (DAC Only)
001	192fs (DAC Only)
010	256fs
011	384fs
100	512fs
101	768fs

**Table 7 Master Mode MCLK:ADCLRC/DACLRC Ratio Select**

Table 8 shows the settings for ADCRATE and DACRATE for common sample rates and ADCMCLK/DACMCLK frequencies.

SAMPLING RATE (DACLRC/ ADCLRC)	System Clock Frequency (MHz)					
	128fs	192fs	256fs	384fs	512fs	768fs
	DACRATE =000	DACRATE =001	ADCRATE/ DACRATE =010	ADCRATE/ DACRATE =011	ADCRATE/ DACRATE =100	ADCRATE/ DACRATE =101
32kHz	4.096	6.144	8.192	12.288	16.384	24.576
44.1kHz	5.6448	8.467	11.2896	16.9340	22.5792	33.8688
48kHz	6.144	9.216	12.288	18.432	24.576	36.864
96kHz	12.288	18.432	24.576	36.864	Unavailable	Unavailable
192kHz	24.576	36.864	Unavailable	Unavailable	Unavailable	Unavailable

**Table 8 Master Mode ADC/DACLRC Frequency Selection**



ADCBCLK and DACBCLK are also generated by the WM8778. The frequency of ADCBCLK and DACBCLK depends on the mode of operation.

In 128/192fs modes (DACRATE=000 or 001) BCLK = MCLK/2. In 256/384/512fs modes (ADCRATE/DACRATE=010 or 011 or 100) BCLK = MCLK/4. However if DSP mode is selected as the audio interface mode then BCLK=MCLK. Note that DSP mode cannot be used in 128fs mode for word lengths greater than 16 bits or in 192fs mode for word lengths greater than 24 bits.

## ZERO DETECT

The WM8778 has a zero detect circuit for each DAC channel, which detects when 1024 consecutive zero samples have been input. The two zero flag outputs (ZFLAGL and ZFLAGR) may be programmed to output the zero detect signals (see Table 9) that may then be used to control external muting circuits. A '1' on ZFLAGL or ZFLAGR indicates a zero detect. The zero detect may also be used to automatically enable the mute by setting IZD. The zero flag output may be disabled by setting DZFM to 00.

DZFM[1:0]	ZFLAGL	ZFLAGR
00	Zero flag disabled	Zero flag disabled
01	Left channel zero	Right channel zero
10	Both channel zero	Both channel zero
11	Either channels zero	Either channel zero

**Table 9 Zero Flag Output Select**

## POWERDOWN MODES

The WM8778 has powerdown control bits allowing specific parts of the WM8778 to be powered off when not being used. Control bit ADCPD powers off the ADC. The ADC input PGAs will be powered down only if ADCPD and AINPD are set. When AINPD is set the bypass path is automatically disabled. The stereo DAC has a separate powerdown control bit, DACPD allowing the DAC to be powered off when not in use. This also switches the analogue outputs VOUTL/R to VMIDDAC to maintain a dc level on the output. The output mixer will be disabled when PDWN is set.

Setting AINPD, ADCPD and DACPD will powerdown everything except the references VMIDADC, ADCREF and VMIDDAC. ADCREF and VMIDDAC can be powered down by setting PDWN, VMIDADC is always active. Setting PDWN will override all other powerdown control bits. It is recommended that AINPD, ADCPD and DACPD are set before setting PDWN. The default is for all blocks to be enabled.

## DIGITAL AUDIO INTERFACE

### MASTER AND SLAVE MODES

The audio interface operates in either Slave or Master mode, selectable using the MS control bit. In both Master and Slave modes DIN is always an input to the WM8778 and DOUT is always an output. The default is Slave mode.

In Slave mode (MS=0) ADCLRC, DACLRC, ADCBCLK and DACBCLK are inputs to the WM8778 (Figure 11). DIN and DACLRC are sampled by the WM8778 on the rising edge of DACBCLK, ADCLRC is sampled on the rising edge of ADCBCLK. ADC data is output on DOUT and changes on the falling edge of ADCBCLK. By setting control bit BCLKINV the polarity of ADCBCLK and DACBCLK may be reversed so that DIN and DACLRC are sampled on the falling edge of DACBCLK, ADCLRC is sampled on the falling edge of ADCBCLK and DOUT changes on the rising edge of ADCBCLK.

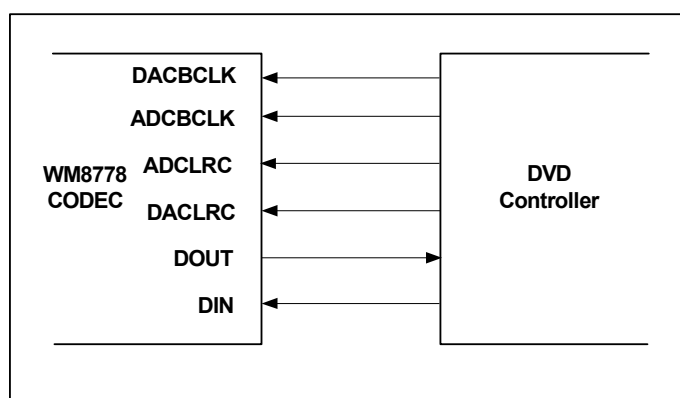


Figure 11 Slave Mode

In Master mode (MS=1) ADCLRC, DACLRC, ADCBCLK and DACBCLK are outputs from the WM8778 (Figure 12). ADCLRC, DACLRC, ADCBCLK and DACBCLK are generated by the WM8778. DIN is sampled by the WM8778 on the rising edge of DACBCLK so the controller must output DAC data that changes on the falling edge of DACBCLK. ADC data is output on DOUT and changes on the falling edge of ADCBCLK. By setting control bit BCLKINV, the polarity of ADCBCLK and DACBCLK may be reversed so that DIN is sampled on the falling edge of DACBCLK and DOUT changes on the rising edge of ADCBCLK.

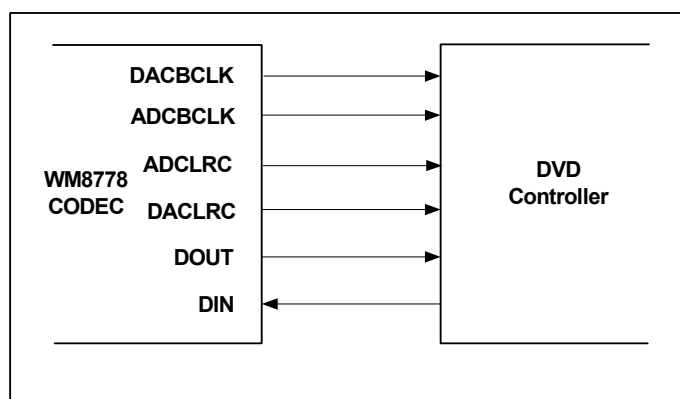


Figure 12 Master Mode

### AUDIO INTERFACE FORMATS

Audio data is applied to the internal DAC filters or output from the ADC filters, via the Digital Audio Interface. 5 popular interface formats are supported:

- Left Justified mode
- Right Justified mode
- I<sup>2</sup>S mode
- DSP mode A
- DSP mode B

All 5 formats send the MSB first and support word lengths of 16, 20, 24 and 32 bits, with the exception of 32 bit right justified mode, which is not supported.

In left justified, right justified and I<sup>2</sup>S modes, the digital audio interface receives DAC data on the DIN input and outputs ADC data on DOUT. Audio Data for each stereo channel is time multiplexed with ADCLRC/DACLRC indicating whether the left or right channel is present. ADCLRC/DACLRC is also used as a timing reference to indicate the beginning or end of the data words.

In left justified, right justified and  $I^2S$  modes; the minimum number of BCLKs per DACLRC/ADCLRC period is 2 times the selected word length. ADCLRC/DACLRC must be high for a minimum of word length BCLKs and low for a minimum of word length BCLKs. Any mark to space ratio on ADCLRC/DACLRC is acceptable provided the above requirements are met.

In DSP mode A or B, DACLRC is used as a frame sync signal to identify the MSB of the first word. The minimum number of DACBCLKs per DACLRC period is 2 times the selected word length. Any mark to space ratio is acceptable on DACLRC provided the rising edge is correctly positioned. The ADC data may also be output in DSP mode A or B, with ADCLRC used as a frame sync to identify the MSB of the first word. The minimum number of ADCBCLKs per ADCLRC period is 2 times the selected word length.

**LEFT JUSTIFIED MODE**

In left justified mode, the MSB of DIN is sampled by the WM8778 on the first rising edge of DACBCLK following a DACLRC transition. The MSB of the ADC data is output on DOUT and changes on the same falling edge of ADCBCLK as ADCLRC and may be sampled on the rising edge of ADCBCLK. ADCLRC and DACLRC are high during the left samples and low during the right samples (Figure 13).

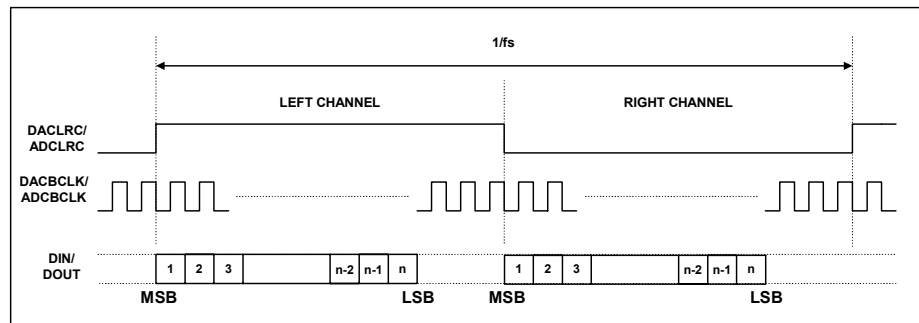


Figure 13 Left Justified Mode Timing Diagram

**RIGHT JUSTIFIED MODE**

In right justified mode, the LSB of DIN is sampled by the WM8778 on the rising edge of DACBCLK preceding a DACLRC transition. The LSB of the ADC data is output on DOUT and changes on the falling edge of ADCBCLK preceding a ADCLRC transition and may be sampled on the rising edge of ADCBCLK. ADCLRC and DACLRC are high during the left samples and low during the right samples (Figure 14).

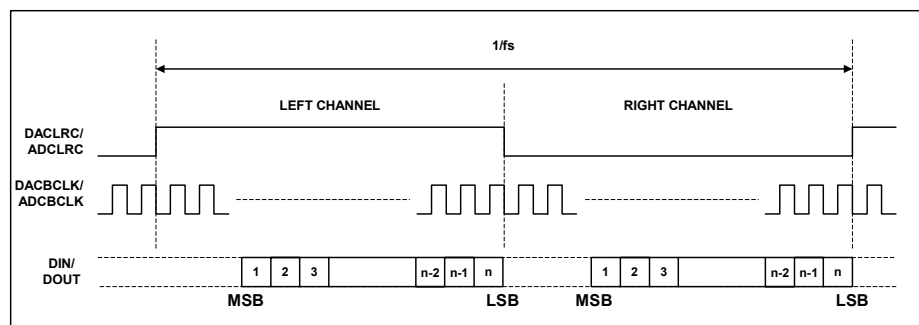


Figure 14 Right Justified Mode Timing Diagram

### I<sup>2</sup>S MODE

In I<sup>2</sup>S mode, the MSB of DIN is sampled by the WM8778 on the second rising edge of DACBCLK following a DACLRC transition. The MSB of the ADC data is output on DOUT and changes on the first falling edge of ADCBCLK following an ADCLRC transition and may be sampled on the rising edge of ADCBCLK. ADCLRC and DACLRC are low during the left samples and high during the right samples.

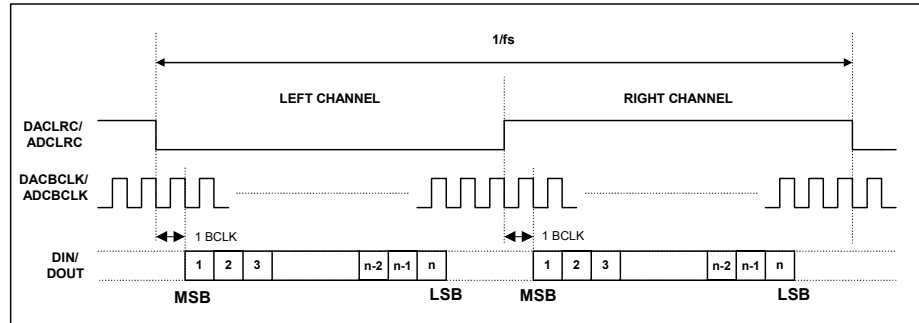


Figure 15 I<sup>2</sup>S Mode Timing Diagram

### DSP MODES

In DSP/PCM mode, the left channel MSB is available on either the 1<sup>st</sup> (mode B) or 2<sup>nd</sup> (mode A) rising edge of BCLK (selectable by LRP) following a rising edge of LRC. Right channel data immediately follows left channel data. Depending on word length, BCLK frequency and sample rate, there may be unused BCLK cycles between the LSB of the right channel data and the next sample.

In device master mode, the LRC output will resemble the frame pulse shown in Figure 16 and Figure 17. In device slave mode, Figure 18 and Figure 19, it is possible to use any length of frame pulse less than 1/fs, providing the falling edge of the frame pulse occurs greater than one BCLK period before the rising edge of the next frame pulse.

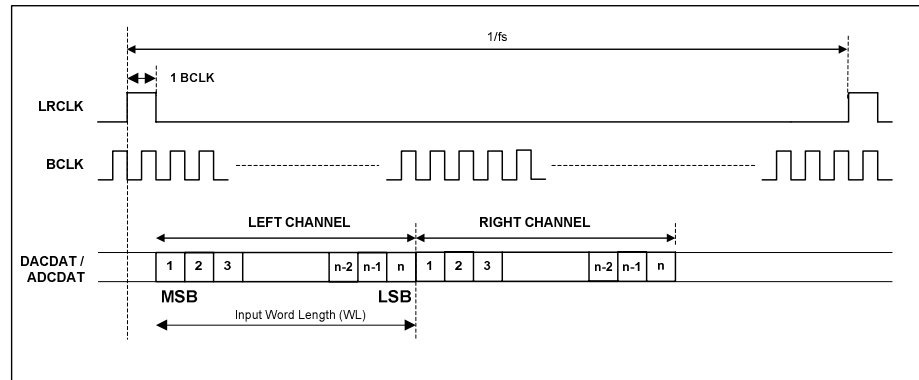


Figure 16 DSP/PCM Mode Audio Interface (mode A, LRP=0, Master)

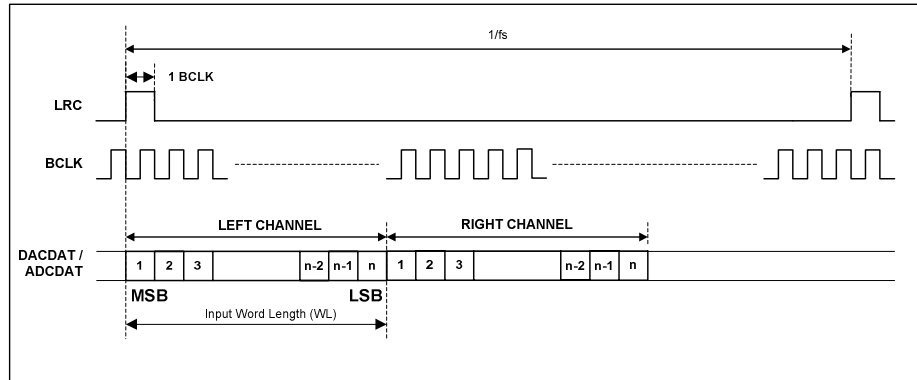


Figure 17 DSP/PCM Mode Audio Interface (mode B, LRP=1, Master)

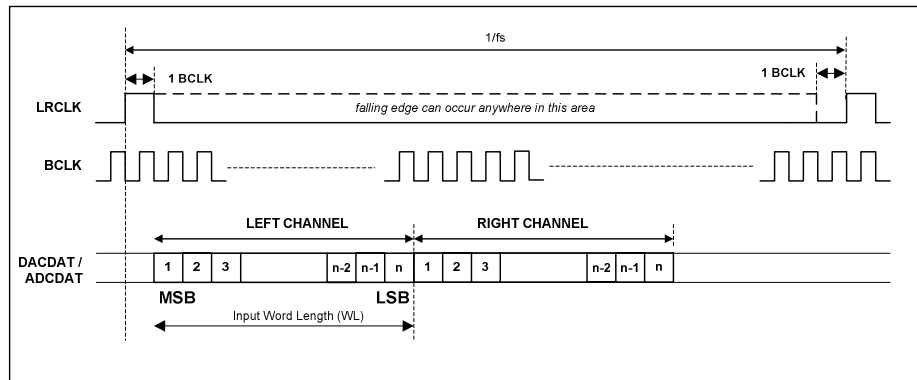


Figure 18 DSP/PCM Mode Audio Interface (mode A, LRP=0, Slave)

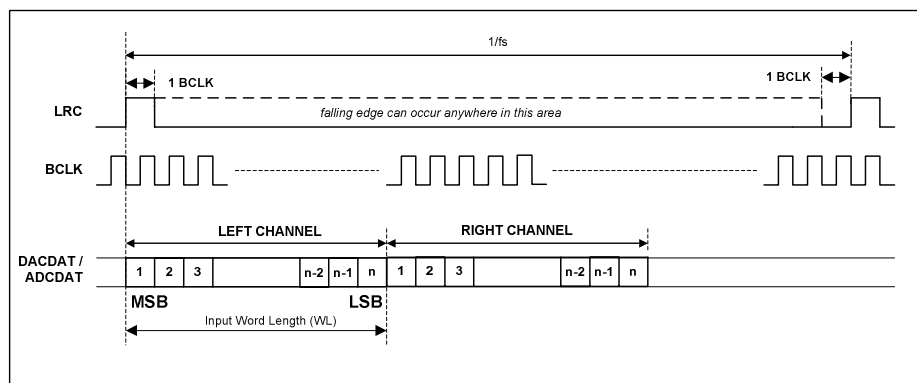


Figure 19 DSP/PCM Mode Audio Interface (mode B, LRP=0, Slave)

## CONTROL INTERFACE OPERATION

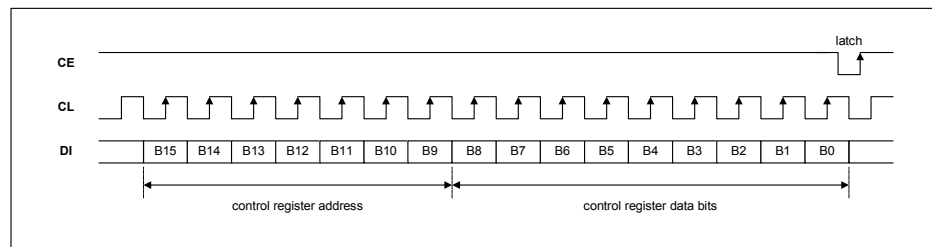
The WM8778 is controlled by writing to registers through a serial control interface. A control word consists of 16 bits. The first 7 bits (B15 to B9) are address bits that select which control register is accessed. The remaining 9 bits (B8 to B0) are data bits, corresponding to the 9 bits in each control register. The control interface can operate as either a 3-wire or 2-wire MPU interface. The MODE pin selects the interface format, as shown in Table 10.

MODE	CONTROL MODE
0	2 wire software
Z / midrail	Hardware
1	3 wire software

**Table 10 Control Interface Selection via MODE Pin**

### 3-WIRE (SPI COMPATIBLE) SERIAL CONTROL MODE

In 3-wire mode, every rising edge of CL clocks in one data bit from the DI pin. A rising edge on CE latches in a complete control word consisting of the last 16 bits. The 3-wire interface protocol is shown in Figure 20.



**Figure 20 3-wire SPI Compatible Interface**

1. B[15:9] are Control Address Bits
2. B[8:0] are Control Data Bits
3. CE is edge sensitive – the data is latched on the rising edge of CE.

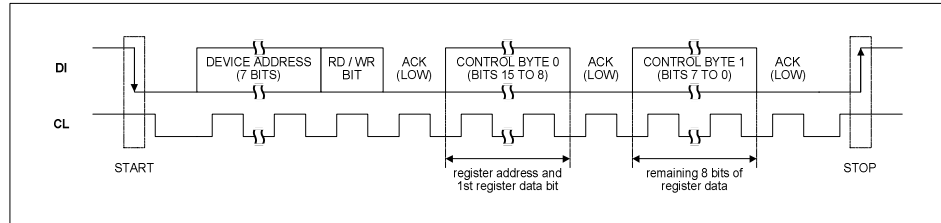
### 2-WIRE SERIAL CONTROL MODE

The WM8778 supports software control via a 2-wire serial bus. Many devices can be controlled by the same bus, and each device has a unique 7-bit address (this is not the same as the 7-bit address of each register in the WM8778).

The WM8778 operates as a slave device only. The controller indicates the start of data transfer with a high to low transition on DI while CL remains high. This indicates that a device address and data will follow. All devices on the 2-wire bus respond to the start condition and shift in the next eight bits on DI (7-bit address + Read/Write bit, MSB first). If the device address received matches the address of the WM8778 and the R/W bit is '0', indicating a write, then the WM8778 responds by pulling DI low on the next clock pulse (ACK). If the address is not recognised or the R/W bit is '1', the WM8778 returns to the idle condition and wait for a new start condition and valid address.

Once the WM8778 has acknowledged a correct address, the controller sends the first byte of control data (B15 to B8, i.e. the WM8778 register address plus the first bit of register data). The WM8778 then acknowledges the first data byte by pulling DI low for one clock pulse. The controller then sends the second byte of control data (B7 to B0, i.e. the remaining 8 bits of register data), and the WM8778 acknowledges again by pulling DI low.

The transfer of data is complete when there is a low to high transition on DI while CL is high. After receiving a complete address and data sequence the WM8778 returns to the idle state and waits for another start condition. If a start or stop condition is detected out of sequence at any point during data transfer (i.e. DI changes while CL is high), the device jumps to the idle condition.



**Figure 21 2-wire Serial Interface**

1. B[15:9] are Control Address Bits
2. B[8:0] are Control Data Bits

The WM8778 has two possible device addresses, which can be selected using the CE pin.

CE STATE	DEVICE ADDRESS
Low	0011010 (0 x 34h)
High	0011011 (0 x 36h)

**Table 11 2-Wire MPU Interface Address Selection**

**HARDWARE MODE**

Hardware mode is selected by applying a midrail voltage to the MODE pin, or by leaving it floating. The circuit detects this condition and enables hardware mode. This allows limited control of the internal functions using the three inputs CE, CL and DI. The table below gives a summary of the use of each pin in hardware mode.

PIN NAME	FUNCTION	DESCRIPTION
CE\I2S	Interface Mode select	0 : Right Justified 1 : I <sup>2</sup> S
CL\IWL	Interface Wordlength select	0 : 20 bit (RJ), 16 bit (I <sup>2</sup> S) 1 : 24 bit
DI\DEEMPH	De-emphasis on/off	0 : De-emphasis disabled 1 : De-emphasis enabled

**Table 12 Hardware Mode Functions**

## CONTROL INTERFACE REGISTERS

## DIGITAL AUDIO INTERFACE CONTROL REGISTER

Interface format is selected via the FMT[1:0] register bits:

REGISTER ADDRESS	BIT	LABEL	DEFAULT	DESCRIPTION
R10 (0Ah) 0001010 DAC Interface Control	1:0	DACFMT [1:0]	10	Interface format Select 00 : right justified mode 01: left justified mode
R11 (0Bh) 0001011 ADC Interface Control	1:0	ADCFMT [1:0]	10	10: I <sup>2</sup> S mode 11: DSP mode A or B

In left justified, right justified or I<sup>2</sup>S modes, the LRP register bit controls the polarity of ADCLRC/DACLRC. If this bit is set high, the expected polarity of ADCLRC/DACLRC will be the opposite of that shown Figure 13, Figure 14, etc. Note that if this feature is used as a means of swapping the left and right channels, a 1 sample phase difference will be introduced. In DSP modes, the LRP register bit is used to select between modes A and B.

REGISTER ADDRESS	BIT	LABEL	DEFAULT	DESCRIPTION
R10 (0Ah) 0001010 DAC Interface Control	2	DACLRC	0	In left/right I <sup>2</sup> S modes: ADCLRC/DACLRC Polarity (normal) 0 : normal ADCLRC/DACLRC polarity 1: inverted ADCLRC/DACLRC polarity
R11 (0Bh) 0001011 ADC Interface Control	2	ADCLRC	0	In DSP mode: 0 : DSP mode A 1: DSP mode B

By default, ADCLRC, DACLRC and DIN are sampled on the rising edge of ADCBCLK and DACBCLK and should ideally change on the falling edge. Data sources that change ADCLRC/DACLRC and DIN on the rising edge of ADCBCLK/DACBCLK can be supported by setting the BCP register bit. Setting BCP to 1 inverts the polarity of BCLK to the inverse of that shown in Figure 13, Figure 14, etc.

REGISTER ADDRESS	BIT	LABEL	DEFAULT	DESCRIPTION
R10 (0Ah) 0001010 DAC Interface Control	3	DACBCP	0	BCLK Polarity (DSP modes) 0 : normal BCLK polarity 1: inverted BCLK polarity
R11 (0Bh) 0001011 ADC Interface Control	3	ADCBCP	0	

The WL[1:0] bits are used to control the input word length.

REGISTER ADDRESS	BIT	LABEL	DEFAULT	DESCRIPTION
R10 (0Ah) 0001010 DAC Interface Control	5:4	DACWL [1:0]	10	Word Length 00 : 16 bit data 01: 20 bit data
R11 (0Bh) 0001011 ADC Interface Control	5:4	ADCWL [1:0]	10	10: 24 bit data 11: 32 bit data

**Note:** If 32-bit mode is selected in right justified mode, the WM8778 defaults to 24 bits.

In all modes, the data is signed 2's complement. The digital filters always input 24-bit data. If the DAC is programmed to receive 16 or 20 bit data, the WM8778 pads the unused LSBs with zeros. If the DAC is programmed into 32 bit mode, the 8 LSBs are ignored.

**Note:** In 24 bit I<sup>2</sup>S mode, any width of 24 bits or less is supported provided that ADCLRC/DACLRC is high for a minimum of 24 BCLKs and low for a minimum of 24 BCLKs.



When operating the ADC digital interface in slave mode, to optimise the performance of the ADC it is recommended that the ADCMCLK and ADCBCLK input signals do not have coinciding rising edges. The ADCMCLK bit provides the option to internally invert the ADCMCLK input signal when the input signals have coinciding rising edges.

REGISTER ADDRESS	BIT	LABEL	DEFAULT	DESCRIPTION
R11(0Bh) 0001011 Interface Control	6	ADCMCLK	0	ADCMCLK Polarity 0 : non-inverted 1: inverted

A number of options are available to control how data from the Digital Audio Interface is applied to the DAC.

#### MASTER MODES

Control bit ADCMS selects between audio interface Master and Slave Modes for ADC. In ADC Master mode ADCLRC and ADCBCLK are outputs and are generated by the WM8778. In Slave mode ADCLRC and ADCBCLK are inputs to WM8778.

REGISTER ADDRESS	BIT	LABEL	DEFAULT	DESCRIPTION
R12 (0Ch) 0001100 Interface Control	8	ADCMS	0	Audio Interface Master/Slave Mode select for ADC: 0 : Slave Mode 1: Master Mode

Control bit DACMS selects between audio interface Master and Slave Modes for the DAC. In DAC Master mode DACLRC and DACBCLK are outputs and are generated by the WM8778. In Slave mode DACLRC and DACBCLK are inputs to WM8778.

REGISTER ADDRESS	BIT	LABEL	DEFAULT	DESCRIPTION
R12 (0Ch) 0001100 Interface Control	7	DACMS	0	Audio Interface Master/Slave Mode select for DAC: 0 : Slave Mode 1: Master Mode

#### MASTER MODE ADCLRC/DACLRC FREQUENCY SELECT

In ADC Master mode the WM8778 generates ADCLRC and ADCBCLK, in DAC master mode the WM8778 generates DACLRC and DACBCLK. These clocks are derived from the master clock (ADCMCLK or DACMCLK). The ratios of ADCMCLK to ADCLRC and DACMCLK to DACLRC are set by ADCRATE and DACRATE respectively.

REGISTER ADDRESS	BIT	LABEL	DEFAULT	DESCRIPTION
R12 (0Ch) 0001100 ADCLRC and DACLRC Frequency Select	2:0	ADCRATE[2:0]	010	Master Mode MCLK:ADCLRC Ratio Select: 010: 256fs 011: 384fs 100: 512fs 101: 768fs
	6:4	DACRATE[2:0]	010	Master Mode MCLK:DACLRC Ratio Select: 000: 128fs 001: 192fs 010: 256fs 011: 384fs 100: 512fs 101: 768fs

### ADC OVERSAMPLING RATE SELECT

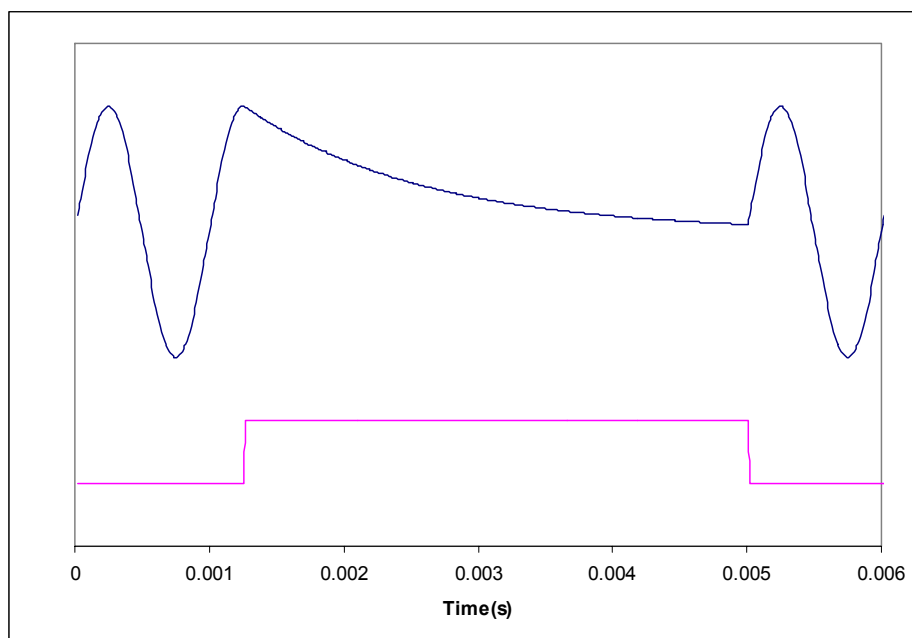
For ADC operation at 96kHz it is recommended that the user set the ADCOSR bit. This changes the ADC signal processing oversample rate to 64fs.

REGISTER ADDRESS	BIT	LABEL	DEFAULT	DESCRIPTION
R12 (0Ch) 0001100 ADC Oversampling Rate	3	ADCOSR	0	ADC Oversampling Rate Select 0: 128x oversampling 1: 64x oversampling

### MUTE MODES

Setting MUTE for the DAC will apply a 'soft' mute to the input of the digital filters of the channel muted.

REGISTER ADDRESS	BIT	LABEL	DEFAULT	DESCRIPTION
R8 (08h) 0001000 DAC Mute	0	DMUTE	0	DAC Soft Mute Select 0 : Normal Operation 1: Soft mute enabled



**Figure 22 Application and Release of Soft Mute**

Figure 22 shows the application and release of DMUTE whilst a full amplitude sinusoid is being played at 48kHz sampling rate. When DMUTE (lower trace) is asserted, the output (upper trace) begins to decay exponentially from the DC level of the last input sample. The output will decay towards  $V_{MID}$  with a time constant of approximately 64 input samples. If DMUTE is applied to both channels for 1024 or more input samples the DAC will be muted if IZD is set. When DMUTE is de-asserted, the output will restart immediately from the current input sample.

Note that all other means of muting the DAC: setting the PL[3:0] bits to 0, setting the PDWN bit or setting attenuation to 0 will cause much more abrupt muting of the output.

**ADC MUTE**

Each ADC channel also has an individual mute control bit, which mutes the input to the ADC PGA. By setting the LRBOTH bit (reg22, bit 8) both channels can be muted simultaneously.

REGISTER ADDRESS	BIT	LABEL	DEFAULT	DESCRIPTION
R21 (15h) 0010101 ADC Mute Left	7	MUTELA	0	ADC Mute Select 0 : Normal Operation 1: mute ADC left
R21 (15h) 0001111 ADC Mute Right	6	MUTERA	0	ADC Mute Select 0 : Normal Operation 1: mute ADC right

**DE-EMPHASIS MODE**

The De-emphasis filter for the DAC is enabled under the control of DEEMP.

REGISTER ADDRESS	BIT	LABEL	DEFAULT	DESCRIPTION
R9 (09h) 0001001 DAC De-emphasis Control	0	DEEMPH	0	De-emphasis Mode Select: 0 : Normal Mode 1: De-emphasis Mode

Refer to Figure 33, Figure 34, Figure 35, Figure 36, Figure 37 and Figure 38 for details of the De-Emphasis modes at different sample rates.

**POWERDOWN MODE AND ADC/DAC DISABLE**

Setting the PDWN register bit immediately powers down the WM8778, including the references, overriding all other powerdown control bits. All trace of the previous input samples is removed, but all control register settings are preserved. When PDWN is cleared, the digital filters will be re-initialised. It is recommended that the buffer, ADC and DAC are powered down before setting PDWN.

REGISTER ADDRESS	BIT	LABEL	DEFAULT	DESCRIPTION
R13 (0Dh) 0001101 Powerdown Control	0	PDWN	0	Power Down Mode Select: 0 : Normal Mode 1: Power Down Mode

The ADC and DAC may also be powered down by setting the ADCPD and DACPD disable bits. Setting ADCPD will disable the ADC and select a low power mode. The ADC digital filters will be reset and will reinitialise when ADCPD is reset. The DAC has a separate disable DACPD. Setting DACPD will disable the DAC, mixer and output PGAs. Resetting DACPD will reinitialise the digital filters.

REGISTER ADDRESS	BIT	LABEL	DEFAULT	DESCRIPTION
R13 (0Dh) 0001101 Powerdown Control	1	ADCPD	0	ADC Powerdown: 0 : Normal Mode 1: Power Down Mode
	2	DACPD	0	DAC Powerdown: 0 : Normal Mode 1: Power Down Mode

The analogue audio inputs and outputs can also be individually powered down by setting the relevant bits in the powerdown register.

REGISTER ADDRESS	BIT	LABEL	DEFAULT	DESCRIPTION
R13 (0Dh) 0001101 Powerdown Control	6	AINPD	0	Analogue Input PGA Disable: 0 : Normal Mode 1: Power Down Mode

#### DIGITAL ATTENUATOR CONTROL MODE

Setting the ATC register bit causes the left channel attenuation settings to be applied to both left and right channel DACs from the next audio input sample. No update to the attenuation registers is required for ATC to take effect.

REGISTER ADDRESS	BIT	LABEL	DEFAULT	DESCRIPTION
R7 (07h) 0000111 DAC Channel Control	1	ATC	0	Attenuator Control Mode: 0 : Right channel use Right attenuation 1: Right Channel use Left Attenuation

#### INFINITE ZERO DETECT ENABLE

Setting the IZD register bit will enable the internal infinite zero detect function:

REGISTER ADDRESS	BIT	LABEL	DEFAULT	DESCRIPTION
R7 (07h) 0000111 DAC Channel Control	2	IZD	0	Infinite Zero Mute Enable 0 : disable infinite zero mute 1: enable infinite zero Mute

With IZD enabled, applying 1024 consecutive zero input samples to the DAC will cause both DAC outputs to be muted. Mute will be removed as soon as any channel receives a non-zero input.

#### DAC OUTPUT CONTROL

The DAC output control word determines how the left and right inputs to the audio Interface are applied to the left and right DACs:

REGISTER ADDRESS	BIT	LABEL	DEFAULT	DESCRIPTION		
				PL[3:0]	Left Output	Right Output
R7 (07h) 0000111 DAC Control	7:4	PL[3:0]	1001	PL[3:0]	Left Output	Right Output
				0000	Mute	Mute
				0001	Left	Mute
				0010	Right	Mute
				0011	(L+R)/2	Mute
				0100	Mute	Left
				0101	Left	Left
				0110	Right	Left
				0111	(L+R)/2	Left
				1000	Mute	Right
				1001	Left	Right
				1010	Right	Right
				1011	(L+R)/2	Right
				1100	Mute	(L+R)/2
				1101	Left	(L+R)/2
				1110	Right	(L+R)/2
1111	(L+R)/2	(L+R)/2				

**DAC DIGITAL VOLUME CONTROL**

The DAC volume may also be adjusted in the digital domain using independent digital attenuation control registers

REGISTER ADDRESS	BIT	LABEL	DEFAULT	DESCRIPTION
R3 (03h) 0000011 Digital Attenuation DACL	7:0	LDA[7:0]	11111111 (0dB)	Digital Attenuation data for Left channel DACL in 0.5dB steps. See Table 13
	8	UPDATED	Not latched	Controls simultaneous update of Attenuation Latches 0: Store LDA in intermediate latch (no change to output) 1: Store LDA and update attenuation on both channels
R4 (04h) 0000100 Digital Attenuation DACR	7:0	RDA[6:0]	11111111 (0dB)	Digital Attenuation data for Right channel DACR in 0.5dB steps. See Table 13
	8	UPDATED	Not latched	Controls simultaneous update of Attenuation Latches 0: Store RDA in intermediate latch (no change to output) 1: Store RDA and update attenuation on both channels.
R5 (05h) 0000101 Master Digital Attenuation (both channels)	7:0	MASTDA[7:0]	11111111 (0dB)	Digital Attenuation data for DAC channels in 0.5dB steps. See Table 13
	8	UPDATED	Not latched	Controls simultaneous update of Attenuation Latches 0: Store gain in intermediate latch (no change to output) 1: Store gain and update attenuation on channels.

L/RDA[7:0]	ATTENUATION LEVEL
00(hex)	-∞ dB (mute)
01(hex)	-127dB
:	:
:	:
:	:
FE(hex)	-0.5dB
FF(hex)	0dB

**Table 13 Digital Volume Control Attenuation Levels**

The digital volume control also incorporates a zero cross detect circuit which detects a transition through the zero point before updating the digital volume control with the new volume. This is enabled by control bit DZCEN.

REGISTER ADDRESS	BIT	LABEL	DEFAULT	DESCRIPTION
R7 (07h) 0000111 DAC Control	0	DZCEN	0	DAC Digital Volume Zero Cross Enable: 0: Zero cross detect disabled 1: Zero cross detect enabled

**DAC OUTPUT PHASE**

The DAC Phase control word determines whether the output of the DAC is non-inverted or inverted

REGISTER ADDRESS	BIT	LABEL	DEFAULT	DESCRIPTION		
R6 (06h) 0000110 DAC Phase	1:0	PHASE [1:0]	00	Bit	DAC	Phase
				0	DACL	1 = invert
				1	DACR	1 = invert

**ADC GAIN CONTROL**

The ADC has an analogue input PGA and digital gain control for each stereo channel. Both the analogue and digital gains are adjusted by the same register, LAG for the left and RAG for the right. The analogue PGA has a range of +24dB to -21dB in 0.5dB steps. The digital gain control allows further attenuation (after the ADC) from -21.5dB to -103dB in 0.5dB steps. Table 14 shows how the register maps the analogue and digital gains.

LAG/RAG[7:0]	ATTENUATION LEVEL (AT OUTPUT)	ANALOGUE PGA	DIGITAL ATTENUATION
00(hex)	-∞ dB (mute)	-21dB	Digital mute
01(hex)	-103dB	-21dB	-82dB
:	:	:	:
A4(hex)	-21.5dB	-21dB	-0.5dB
A5(hex)	-21dB	-21dB	0dB
:	:	:	:
CF(hex)	0dB	0dB	0dB
:	:	:	:
FE(hex)	+23.5dB	+23.5dB	0dB
FF(hex)	+24dB	+24dB	0dB

**Table 14 Analogue and Digital Gain Mapping for ADC**

In addition a zero cross detect circuit is provided for the input PGA. When ZCLA/ZCRA is set with a write, the gain will update only when the input signal approaches zero (midrail). This minimises audible clicks and 'zipper' noise as the gain values change. A timeout clock is also provided which will generate an update after a minimum of 131072 master clocks (= ~10.5ms with a master clock of 12.288MHz). The timeout clock may be disabled by setting TOD.

REGISTER ADDRESS	BIT	LABEL	DEFAULT	DESCRIPTION
R7 (07h) 0000111 Timeout Clock Disable	3	TOD	0	Analogue PGA Zero Cross Detect Timeout Disable 0 : Timeout enabled 1: Timeout disabled

Left and right inputs may also be independently muted. The LRBOTH control bit allows the user to write the same attenuation value to both left and right volume control registers, saving on software writes. The ADC volume and mute also applies to the bypass signal path.

REGISTER ADDRESS	BIT	LABEL	DEFAULT	DESCRIPTION
R14 (0Eh) 0001110 Attenuation ADCL	7:0	LAG[7:0]	11001111 (0dB)	Attenuation Data for Left Channel ADC Gain in 0.5dB steps. See Table 14.
	8	ZCLA	0	Left Channel ADC Zero Cross Enable: 0: Zero cross disabled 1: Zero cross enabled
R15 (0Fh) 0001111 Attenuation ADCR	7:0	RAG[7:0]	11001111 (0dB)	Attenuation data for right channel ADC gain in 0.5dB steps. See Table 14.
	8	ZCRA	0	Right Channel ADC Zero Cross Enable: 0: Zero cross disabled 1: Zero cross enabled
R21 (15h) 0010101 ADC Input Mux	6	MUTERA	0	Mute for Right Channel ADC 0: Mute Off 1: Mute on
	7	MUTELA	0	Mute for Left Channel ADC 0: Mute Off 1: Mute on
	8	LRBOTH	0	Right Channel Input PGA Controlled by Left Channel Register 0 : Right channel uses RAG and MUTERA. 1 : Right channel uses LAG and MUTELA.

#### ADC HIGHPASS FILTER DISABLE

The ADC digital filters contain a digital high pass filter. This defaults to enabled and can be disabled using software control bit ADCHPD.

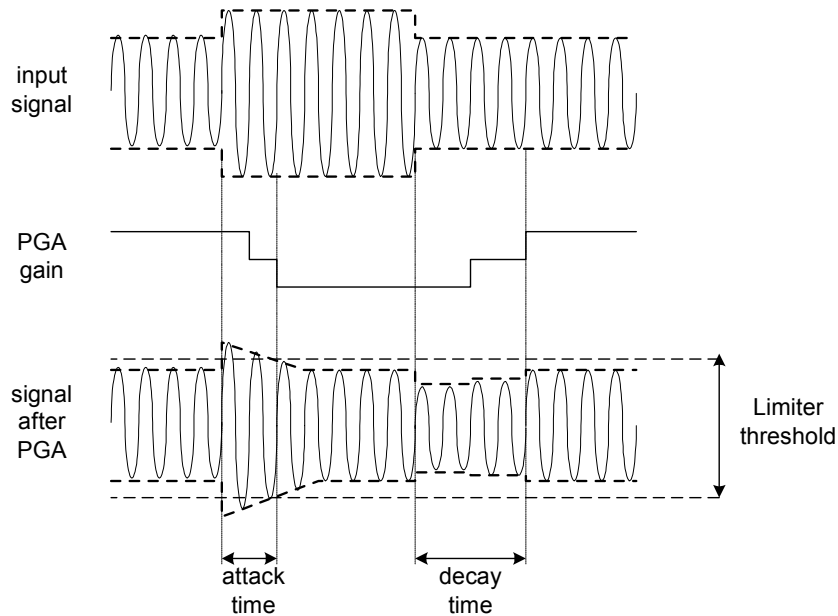
REGISTER ADDRESS	BIT	LABEL	DEFAULT	DESCRIPTION
R11 (0Bh) 0001011 ADC Control	8	ADCHPD	0	ADC High Pass Filter Disable: 0: High pass filter enabled 1: High pass filter disabled

#### ADC OUTPUT PHASE

In the ADC to DOUT data path, the digital output data DOUT, is a phase inverted representation of the analogue input signal.

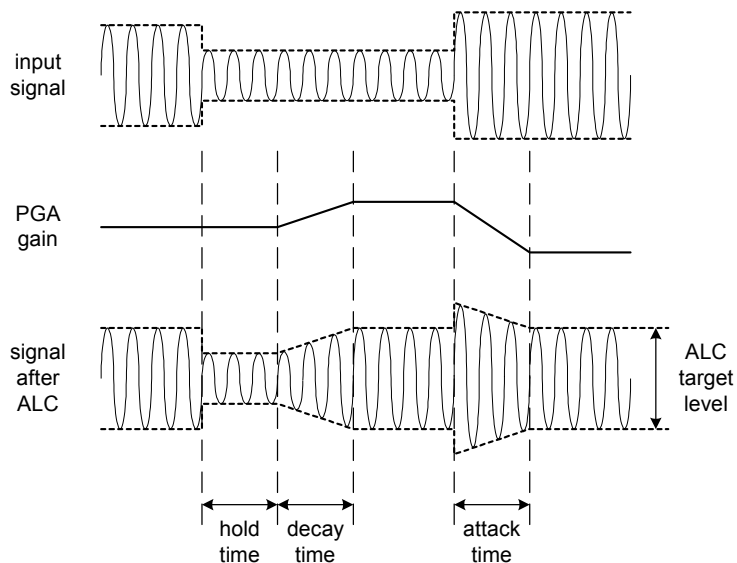
**LIMITER / AUTOMATIC LEVEL CONTROL (ALC)**

The WM8778 has an automatic pga gain control circuit, which can function as a peak limiter or as an automatic level control (ALC). In peak limiter mode, a digital peak detector detects when the input signal goes above a predefined level and will ramp the pga gain down to prevent the signal becoming too large for the input range of the ADC. When the signal returns to a level below the threshold, the pga gain is slowly returned to its starting level. The peak limiter cannot increase the pga gain above its static level.



**Figure 23 Limiter Operation**

In ALC mode, the circuit aims to keep a constant recording volume irrespective of the input signal level. This is achieved by continuously adjusting the PGA gain so that the signal level at the ADC input remains constant. A digital peak detector monitors the ADC output and changes the PGA gain if necessary.



**Figure 24 ALC Operation**



The gain control circuit is enabled by setting the LCEN control bit. The user can select between Limiter mode and three different ALC modes using the LCSEL control bits.

REGISTER ADDRESS	BIT	LABEL	DEFAULT	DESCRIPTION
R17 (11h) 0010001 ALC Control 2	8	LCEN	0	Enable the PGA Gain Control Circuit. 0 = Disabled 1 = Enabled
R16 (10h) 0010000 ALC Control 1	8:7	LCSEL	00	LC Function Select 00 = Limiter 01 = ALC Right channel only 10 = ALC Left channel only 11 = ALC Stereo

The limiter function only operates in stereo, which means that the peak detector takes the maximum of left and right channel peak values, and any new gain setting is applied to both left and right PGAs, so that the stereo image is preserved. However, the ALC function can also be enabled on one channel only. In this case, only one PGA is controlled by the ALC mechanism, while the other channel runs independently with its PGA gain set through the control register.

When enabled, the threshold for the limiter or target level for the ALC is programmed using the LCT control bits. This allows the threshold/target level to be programmed between -1dB and -16dB in 1dB steps. Note that for the ALC, target levels of -1dB and -2dB give a threshold of -3dB. This is because the ALC can give erroneous operation if the target level is set too high.

REGISTER ADDRESS	BIT	LABEL	DEFAULT	DESCRIPTION
R16 (10h) 0010000 ALC Control 1	3:0	LCT[3:0]	1011 (-5dB)	Limiter Threshold/ALC Target Level in 1dB Steps: 0000: -16dB FS 0001: -15dB FS ... 1101: -3dB FS 1110: -2dB FS 1111: -1dB FS

### ATTACK AND DECAY TIMES

The limiter and ALC have different attack and decay times which determine their operation. However, the attack and decay times are defined slightly differently for the limiter and for the ALC. DCY and ATK control the decay and attack times, respectively.

**Decay time** (Gain Ramp-Up). When in ALC mode, this is defined as the time that it takes for the PGA gain to ramp up across 90% of its range (e.g. from -21dB up to +20 dB). When in limiter mode, it is defined as the time it takes for the gain to ramp up by 6dB.

The decay time can be programmed in power-of-two ( $2^n$ ) steps. For the ALC this gives times from 33.6ms, 67.2ms, 134.4ms etc. to 34.41s. For the limiter this gives times from 1.2ms, 2.4ms etc., up to 1.2288s.

**Attack time** (Gain Ramp-Down) When in ALC mode, this is defined as the time that it takes for the PGA gain to ramp down across 90% of its range (e.g. from +20dB down to -21dB gain). When in limiter mode, it is defined as the time it takes for the gain to ramp down by 6dB.

The attack time can be programmed in power-of-two ( $2^n$ ) steps, from 8.4ms, 16.8ms, 33.6ms etc. to 8.6s for the ALC and from 250us, 500us, etc. up to 256ms.

The time it takes for the recording level to return to its target value or static gain value therefore depends on both the attack/decay time and on the gain adjustment required. If the gain adjustment is small, it will be shorter than the attack/decay time.

REGISTER ADDRESS	BIT	LABEL	DEFAULT	DESCRIPTION	
R18 (12h) 0010010 ALC Control 3	3:0	ATK[3:0]	0010	LC Attack (Gain Ramp-down) Time	
				ALC mode 0000: 8.4ms 0001: 16.8ms 0010: 33.6ms... (time doubles with every step) 1010 or higher: 8.6s	Limiter Mode 0000: 250us 0001: 500us... 0010: 1ms (time doubles with every step) 1010 or higher: 256ms
	7:4	DCY [3:0]	0011	LC Decay (Gain Ramp-up) Time	
				ALC mode 0000: 33.5ms 0001: 67.2ms 0010: 134.4ms ....(time doubles for every step) 1010 or higher: 34.3 ms	Limiter mode 0000: 1.2ms 0001: 2.4ms 0010: 4.8ms ....(time doubles for every step) 1010 or higher: 1.2288s

#### TRANSIENT WINDOW (LIMITER ONLY)

To prevent the limiter responding to short duration high amplitude signals (such as hand-claps in a live performance), the limiter has a programmable transient window preventing it responding to signals above the threshold until their duration exceeds the window period. The Transient window is set in register TRANWIN.

REGISTER ADDRESS	BIT	LABEL	DEFAULT	DESCRIPTION
R20 (14h) 0010100 Limiter Control	6:4	TRANWIN [2:0]	010	Length of Transient Window: 000: 0us (disabled) 001: 62.5us 010: 125us ..... 111: 4ms

#### ZERO CROSS

The PGA has a zero cross detector to prevent gain changes introducing noise to the signal. In ALC mode the register bit ALCZC allows this to be turned off if desired.

REGISTER ADDRESS	BIT	LABEL	DEFAULT	DESCRIPTION
R17 (11h) 0010001 ALC Control 2	7	ALCZC	0 (disabled)	PGA Zero Cross Enable: 0 : disabled 1: enabled

**MAXIMUM GAIN (ALC ONLY) AND MAXIMUM ATTENUATION**

To prevent low level signals being amplified too much by the ALC, the MAXGAIN register sets the upper limit for the gain. This prevents low level noise being over-amplified. The MAXGAIN register has no effect on the limiter operation.

The register has different operation for the limiter and for the ALC. For the limiter it defines the maximum attenuation below the static (user programmed) gain. For the ALC, it defines the lower limit for the gain.

REGISTER ADDRESS	BIT	LABEL	DEFAULT	DESCRIPTION
R16 (10h) 0010000 ALC Control 1	6:4	MAXGAIN	111 (+24dB)	Set Maximum Gain for the PGA (ALC only): 111 : +24dB 110 : +20dB .....(-4dB steps) 010 : +4dB 001 : 0dB 000 : 0dB
R20 (14h) 0010100 Limiter Control	3:0	MAXATTEN	0110	Maximum Attenuation of PGA Limiter (attenuation below static) 0011 or lower : -3dB 0100: -4dB .... (-1dB steps) 1100 or higher : -12dB ALC (lower PGA gain limit) 1010 or lower : -1dB 1011 : -5dB ..... (-4dB steps) 1110 : -17dB 1111 : -21dB

**HOLD TIME (ALC ONLY)**

The ALC also has a hold time, which is the time delay between the peak level detected being below target and the PGA gain beginning to ramp up. It can be programmed in power-of-two ( $2^n$ ) steps, e.g. 2.67ms, 5.33ms, 10.67ms etc. up to 43.7ms. Alternatively, the hold time can also be set to zero. The hold time only applies to gain ramp-up, there is no delay before ramping the gain down when the signal level is above target.

REGISTER ADDRESS	BIT	LABEL	DEFAULT	DESCRIPTION
R17 (11h) 0010001 ALC Control 2	3:0	HLD[3:0]	0000	ALC Hold Time Before Gain is Increased: 0000: 0ms 0001: 2.67ms 0010: 5.33ms ... (time doubles with every step) 1111: 43.691s

**OVERLOAD DETECTOR (ALC ONLY)**

To prevent clipping when a large signal occurs just after a period of quiet, the ALC circuit includes an overload detector. If the ADC input signal exceeds 87.5% of full scale ( $-1.16\text{dB}$ ), the PGA gain is ramped down at the maximum attack rate (as when  $\text{ATK} = 0000$ ), until the signal level falls below 87.5% of full scale. This function is automatically enabled whenever the ALC is enabled.

(Note: If  $\text{ATK} = 0000$ , then the overload detector makes no difference to the operation of the ALC. It is designed to prevent clipping when long attack times are used).

**NOISE GATE (ALC ONLY)**

When the signal is very quiet and consists mainly of noise, the ALC function may cause “noise pumping”, i.e. loud hissing noise during silence periods. The WM8778 has a noise gate function that prevents noise pumping by comparing the signal level at the  $\text{AINL1/2/3/4/5}$  and/or  $\text{AINR1/2/3/4/5}$  pins against a noise gate threshold,  $\text{NGTH}$ . The noise gate cuts in when:

- Signal level at ADC [dB] <  $\text{NGTH [dB]} + \text{PGA gain [dB]} + \text{Mic Boost gain [dB]}$

This is equivalent to:

- Signal level at input pin [dB] <  $\text{NGTH [dB]}$

When the noise gate is triggered, the PGA gain is held constant (preventing it from ramping up as it would normally when the signal is quiet).

The table below summarises the noise gate control register. The  $\text{NGTH}$  control bits set the noise gate threshold with respect to the ADC full-scale range. The threshold is adjusted in 6dB steps. Levels at the extremes of the range may cause inappropriate operation, so care should be taken with set-up of the function. Note that the noise gate only works in conjunction with the ALC function, and always operates on the same channel(s) as the ALC (left, right, both, or none).

REGISTER ADDRESS	BIT	LABEL	DEFAULT	DESCRIPTION
R19 (13h) 0010011 Noise Gate Control	0	NGAT	0	Noise Gate Function Enable: 1 = enable 0 = disable
	4:2	NGTH[2:0]	000	Noise Gate Threshold (with respect to ADC output level): 000: $-78\text{dBFS}$ 001: $-72\text{dBfs}$ ... 6 dB steps 110: $-42\text{dBFS}$ 111: $-36\text{dBFS}$

### OUTPUT SELECT AND ENABLE CONTROL

Register bits MXDAC and MXBYP controls the output selection. The output select block consists of a summing stage and an input select switch for each input allowing each signal to be output individually or summed with other signals and output on the analogue output. The default for the output is DAC playback only. VOUT may be selected to output DAC playback, analogue bypass or a sum of the two using the output select controls MXDAC and MXBYP.

The output mixer is powered down when PDWN is set. The bypass path is automatically deselected when AINPD is set.

REGISTER ADDRESS	BIT	LABEL	DEFAULT	DESCRIPTION
R22 (16h) 0010110 Output Mux	0	MXDAC	1 (DAC playback)	VOUT Output Select DAC (see Figure 25)
	2	MXBYP	0 (not selected)	VOUT Output Select Bypass Path.

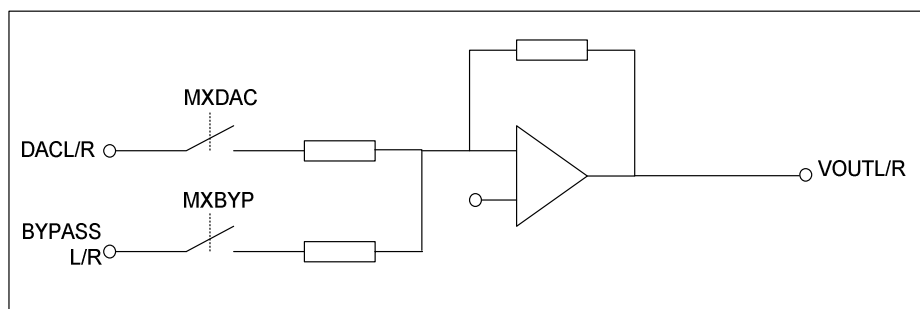


Figure 25 MX[2:0] Output Select

### SOFTWARE REGISTER RESET

Writing any value to register 0010111 will cause a register reset, resetting all register bits to their default values.

## REGISTER MAP

The complete register map is shown below. The detailed description can be found in the relevant text of the device description. The WM8778 can be configured using the Control Interface. All unused bits should be set to '0'.

REGISTER	B15	B14	B13	B12	B11	B10	B9	B8	B7	B6	B5	B4	B3	B2	B1	B0	DEFAULT (HEX)	
R3 (03h)	0	0	0	0	0	1	1	UPDATED	LDA[7:0]							OFF		
R4 (04h)	0	0	0	0	1	0	0	UPDATED	RDA[7:0]							OFF		
R5 (05h)	0	0	0	0	1	0	1	UPDATED	MASTDA[7:0]							OFF		
R6 (06h)	0	0	0	0	1	1	0	0	0	0	0	0	0	0	PHASE[1:0]		000	
R7 (07h)	0	0	0	0	1	1	1	0	PL[3:0]			TOD	IZD	ATC	DZCEN		090	
R8 (08h)	0	0	0	1	0	0	0	0	0	0	0	0	0	0	0	DMUTE		000
R9 (09h)	0	0	0	1	0	0	1	0	0	0	0	0	0	DZFM[1:0]		DEEMPH		000
R10 (0Ah)	0	0	0	1	0	1	0	0	0	DACWL[1:0]		DACBCP	ADCLRP	DACFMT[1:0]			022	
R11 (0Bh)	0	0	0	1	0	1	1	ADCHPD	0	ADCMCLK	ADCWL[1:0]		ADCBCP	ADCLRP	ADCFMT[1:0]		022	
R12 (0Ch)	0	0	0	1	1	0	0	ADCMS	DACMS	DACRATE[2:0]			ADCSR	ADCRATE[2:0]			022	
R13 (0Dh)	0	0	0	1	1	0	1	0	0	AINPD	0	0	0	DACPD	ADCPD	PDWN		000
R14 (0Eh)	0	0	0	1	1	1	0	ZCLA	LAG[7:0]							0CF		
R15 (0Fh)	0	0	0	1	1	1	1	ZCRA	RAG[7:0]							0CF		
R16 (10h)	0	0	1	0	0	0	0	LCSEL[1:0]		MAXGAIN[2:0]			LCT[3:0]			07B		
R17 (11h)	0	0	1	0	0	0	1	LCEN	ALCZC	0	0	0	HLD[3:0]			000		
R18 (12h)	0	0	1	0	0	1	0	0	DCY[3:0]			ATK[3:0]			032			
R19 (13h)	0	0	1	0	0	1	1	0	0	0	0	NGTH[2:0]		0	NGAT		000	
R20 (14h)	0	0	1	0	1	0	0	0	1	TRANWIN[2:0]			MAXATTEN[3:0]			0A6		
R21 (15h)	0	0	1	0	1	0	1	LRBOTH	MUTELA	MUTERA	0	0			000			
R22 (16h)	0	0	1	0	1	1	0	0	0	0			MXBYP	0	MXDAC		001	
R23 (17h)	0	0	1	0	1	1	1	SOFTWARE RESET							not reset			

REGISTER ADDRESS	BIT	LABEL	DEFAULT	DESCRIPTION			
R3 (03h) 0000011 Digital Attenuation DACL	7:0	LDA[7:0]	11111111 (0dB)	Digital Attenuation Data for Left Channel DACL in 0.5dB Steps.			
	8	UPDATED	Not latched	Controls Simultaneous Update of all Attenuation Latches 0: Store LDA1 in intermediate latch (no change to output) 1: Store LDA1 and update attenuation on all channels			
R4 (04h) 0000100 Digital Attenuation DACR	7:0	RDA[6:0]	11111111 (0dB)	Digital Attenuation Data for Right Channel DACR in 0.5dB Steps.			
	8	UPDATED	Not latched	Controls Simultaneous Update of all Attenuation Latches 0: Store RDA1 in intermediate latch (no change to output) 1: Store RDA1 and update attenuation on all channels.			
R5 (05h) 0000101 Master Digital Attenuation (All Channels)	7:0	MASTDA[7:0]	11111111 (0dB)	Digital Attenuation Data for all DAC Channels in 0.5dB Steps.			
	8	UPDATED	Not latched	Controls Simultaneous Update of all Attenuation Latches 0: Store gain in intermediate latch (no change to output) 1: Store gain and update attenuation on all channels.			
R6 (06h) 0000110 Phase Swaps	1:0	PHASE	00	Controls Phase of DAC Outputs (LEFT, RIGHT Channel) 0: Sets non inverted output phase 1: inverts phase of DAC output			
R7 (07h) 0000111 DAC Control	0	DZCEN	0	DAC Digital Volume Zero Cross Enable: 0: Zero Cross detect disabled 1: Zero Cross detect enabled			
	1	ATC	0	Attenuator Control: 0: All DACs use attenuations as programmed. 1: Right DAC uses left DAC attenuations			
	2	IZD	0	Infinite Zero Detection Circuit Control and Automute Control 0: Infinite zero detect automute disabled 1: Infinite zero detect automute enabled			
	3	TOD	0	DAC and ADC Analogue Zero Cross Detect Timeout Disable 0 : Timeout enabled 1: Timeout disabled			
	7:4	PL[3:0]	1001	DAC Output Control			
		PL[3:0]	Left Output	Right Output	PL[3:0]	Left Output	Right Output
		0000	Mute	Mute	1000	Mute	Right
		0001	Left	Mute	1001	Left	Right
		0010	Right	Mute	1010	Right	Right
		0011	(L+R)/2	Mute	1011	(L+R)/2	Right
	0100	Mute	Left	1100	Mute	(L+R)/2	
	0101	Left	Left	1101	Left	(L+R)/2	
	0110	Right	Left	1110	Right	(L+R)/2	
	0111	(L+R)/2	Left	1111	(L+R)/2	(L+R)/2	
R8 (08h) 0001000 DAC Mute	0	DMUTE	0	DAC Channel Soft Mute Enables: 0: mute disabled 1: mute enabled			

REGISTER ADDRESS	BIT	LABEL	DEFAULT	DESCRIPTION		
R9 (09h) 0001001 DAC Control	0	DEEMP	0	De-emphasis Mode Select: 0 : Normal Mode 1: De-emphasis Mode		
	2:1	DZFM	00	DZFM	ZFLAG1	ZFLAG2
				00 01 10 11	disabled left channels zero both channels zero either channel zero	disabled right channels zero both channels zero either channel zero
R10 (0Ah) 0001010 DAC Interface Control	1:0	DACFMT[1:0]	10	DAC Interface Format Select: 00: right justified mode 01: left justified mode 10: I <sup>2</sup> S mode 11: DSP mode		
	2	DACLRP	0	DACLRC Polarity or DSP Mode A or B Select		
				Left Justified / Right Justified / I <sup>2</sup> S: 0: Standard DACLRC Polarity 1: Inverted DACLRC Polarity	DSP Mode: 0: Mode A 1: Mode B	
	3	DACBCP	0	DAC BITCLK Polarity: 0: Normal – DIN and DACLRC sampled on rising edge of DACBCLK. 1: Inverted - DIN and DACLRC sampled on falling edge of DACBCLK.		
5:4	DACWL[1:0]	10	DAC Input Word Length: 00: 16-bit Mode 01: 20-bit Mode 10: 24-bit Mode 11: 32-bit Mode (not supported in right justified mode)			
R11 (0Bh) 0001011 ADC Interface Control	1:0	ADCFMT[1:0]	10	ADC Interface Format Select: 00: right justified mode 01: left justified mode 10: I <sup>2</sup> S mode 11: DSP mode		
	2	ADCLRP	0	ADCLRC Polarity or DSP mode A or B select		
				Left Justified / Right Justified / I <sup>2</sup> S: 0: Standard ADCLRC Polarity 1: Inverted ADCLRC Polarity	DSP Mode: 0: Mode A 1: Mode B	
	3	ADCBCP	0	ADC BITCLK Polarity: 0: Normal - ADCLRC sampled on rising edge of ADCBCLK; DOUT changes on falling edge of ADCBCLK. 1: Inverted - ADCLRC sampled on falling edge of ADCBCLK; DOUT changes on rising edge of ADCBCLK.		
	5:4	ADCWL[1:0]	10	ADC Input Word Length: 00: 16-bit Mode 01: 20-bit Mode 10: 24-bit Mode 11: 32-bit Mode (not supported in right justified mode)		
	6	ADCMCLK	0	ADCMCLK Polarity:		
0: non-inverted 1: inverted						



REGISTER ADDRESS	BIT	LABEL	DEFAULT	DESCRIPTION
	8	ADCHPD	0	ADC Highpass Filter Disable: 0: Highpass Filter enabled 1: Highpass Filter disabled
R12 (0Ch) 0001100 Master Mode Control	2:0	ADCRATE[2:0]	010	Master Mode ADCMCLK:ADCLRC Ratio Select: 010: 256fs 011: 384fs 100: 512fs 101: 768fs
	3	ADCOSR	0	ADC Oversample Rate Select: 0: 128x oversampling 1: 64x oversampling
	6:4	DACRATE[2:0]	010	Master Mode DACMCLK:DACLRC Ratio Select: 000: 128fs 001: 192fs 010: 256fs 011: 384fs 100: 512fs 101: 768fs
	7	DACMS	0	DAC Maser/Slave Interface Mode Select: 0: Slave Mode – DACLRC and DACBCLK are inputs 1: Master Mode – DACLRC and DACBCLK are outputs
	8	ADCMS	0	ADC Maser/Slave Interface Mode Select: 0: Slave Mode – ADCLRC and ADCBCLK are inputs 1: Master Mode – ADCLRC and ADCBCLK are outputs
	R13 (0Dh) 0001101 PWR Down Control	0	PDWN	0
1		ADCPD	0	ADC Powerdown: 0: ADC enabled 1: ADC disabled
2		DACPD	0	DAC Powerdown: 0: DAC enabled 1: DAC disabled
6		AINPD	0	AINPD Powerdown: 0: ANALOGUE INPUT enabled 1: ANALOGUE INPUT disabled
R14 (0Eh) 0001110 Attenuation ADCL	7:0	LAG[7:0]	11001111 (0dB)	Attenuation Data for Left Channel ADC Gain in 0.5dB Steps: 00000000 : digital mute 00000001 : -103dB ..... 11001111 : 0dB ..... 11111110 : +23.5dB 11111111 : +24dB
	8	ZCLA	0	Left ADC Zero Cross Enable: 0: Zero cross disabled 1: Zero cross enabled

REGISTER ADDRESS	BIT	LABEL	DEFAULT	DESCRIPTION
R15 (0Fh) 0001111 Attenuation ADCR	7:0	RAG[7:0]	11001111 (0dB)	Attenuation Data for Right Channel ADC Gain in 0.5dB Steps: 00000000 : digital mute 00000001 : -103dB ..... 11001111 : 0dB ..... 11111110 : +23.5dB 11111111 : +24dB
	8	ZCRA	0	Right ADC Zero Cross Enable: 0: Zero cross disabled 1: Zero cross enabled
R16 (10h) 0010000 ALC Control 1	3:0	LCT[3:0]	1011 (-5dB)	Limiter Threshold/ALC Target Level in 1dB Steps: 0000: -16dB FS 0001: -15dB FS ... 1101: -3dB FS 1110: -2dB FS 1111: -1dB FS
	6:4	MAXGAIN[2:0]	111 (+24dB)	Set Maximum Gain of PGA: 111 : +24dB 110 : +20dB ...(-4dB steps) 010 : +4dB 001 : 0dB 000 : 0dB
	8:7	LCSEL[1:0]	00 (Limiter)	ALC/Limiter Function Select: 00 = Limiter 01 = ALC Right channel only 10 = ALC Left channel only 11 = ALC Stereo (PGA registers unused)
R17 (11h) 0010001 ALC Control 2	3:0	HLD[3:0]	0000 (OFF)	ALC Hold Time Before Gain is Increased: 0000: OFF 0001: 2.67ms 0010: 5.33ms ... (time doubles with every step) 1111: 43.691s
	7	ALCZC	0 (zero cross off)	ALC Uses Zero Cross Detection Circuit.
	8	LCEN	0	Enable Gain Control Circuit. 0 = Disable 1 = Enable

REGISTER ADDRESS	BIT	LABEL	DEFAULT	DESCRIPTION
R18 (12h) 0011000 ALC Control 3	3:0	ATK[3:0]	0010 (33ms/1ms)	ALC/Limiter Attack (gain ramp-down) Time ALC Mode 0000: 8.4ms 0001: 16.8ms 0010: 33.6ms... (time doubles with every step) 1010 or higher: 8.6s Limiter Mode 0000: 250us 0001: 500us... 0010: 1ms (time doubles with every step) 1010 or higher: 256ms
	7:4	DCY[3:0]	0011 (268ms/ 9.6ms)	ALC/Limiter Decay (gain ramp up) Time ALC Mode 0000: 33.5ms 0001: 67.2ms 0010: 134.4ms ... (time doubles for every step) 1010 or higher: 34.3ms Limiter Mode 0000: 1.2ms 0001: 2.4ms 0010: 4.8ms ... (time doubles for every step) 1010 or higher: 1.2288s
R19 (13h) 0010011 Noise Gate Control	0	NGAT	0	Noise Gate Enable (ALC only): 0 : disabled 1 : enabled
	4:2	NGTH	000	Noise Gate Threshold: 000: -78dBFS 001: -72dBfs ... 6 dB steps 110: -42dBFS 111: -36dBFS
R20 (14h) 0010100 Limiter Control	3:0	MAXATTEN [3:0]	0110	Maximum Attenuation of PGA Limiter (attenuation below static) 0011 or lower: -3dB 0100: -4dB .... (-1dB steps) 1100 or higher: -12dB ALC (lower PGA gain limit) 1010 or lower: -1dB 1011 : -5dB ..... (-4dB steps) 1110 : -17dB 1111 : -21dB
	6:4	TRANWIN [2:0]	010	Length of Transient Window: 000: 0us (disabled) 001: 62.5us 010: 125us ..... 111: 4ms
R21 (15h) 0010101 ADC Mux Control	6	MUTERA	0	Mute for Right Channel ADC: 0: Mute off 1: Mute on
	7	MUTELA	0	Mute for Left Channel ADC: 0: Mute off 1: Mute on
	8	LRBOTH	0	Right Channel Input PGA Controlled by Left Channel Register: 0 : Right channel uses RAG and MUTERA. 1 : Right channel uses LAG and MUTELA.
R22 (16h) 0010110 Output Mux	0	MXDAC	1 (DAC playback)	VOUT Output Select DAC (see Figure 22)
	2	MXBYP	0 (not selected)	VOUT Output Select Bypass Path.

**WM8778**

Production Data

REGISTER ADDRESS	BIT	LABEL	DEFAULT	DESCRIPTION
R23 (17h) 0010111 Software Reset	[8:0]	RESET	Not reset	Writing to this register will apply a reset to the device registers.

### DIGITAL FILTER CHARACTERISTICS

PARAMETER	TEST CONDITIONS	MIN	TYP	MAX	UNIT
<b>ADC Filter</b>					
Passband	$\pm 0.01$ dB	0		0.4535fs	
	-6dB		0.5fs		
Passband ripple				$\pm 0.01$	dB
Stopband		0.5465fs			
Stopband Attenuation	$f > 0.5465fs$	-65			dB
Group Delay			22		fs
<b>DAC Filter</b>					
Passband	$\pm 0.05$ dB			0.454fs	
	-3dB		0.4892 fs		
Passband ripple				$\pm 0.05$	dB
Stopband		0.546fs			
Stopband Attenuation	$f > 0.546fs$	-60			dB
Group Delay			19		fs

Table 15 Digital Filter Characteristics

### DAC FILTER RESPONSES

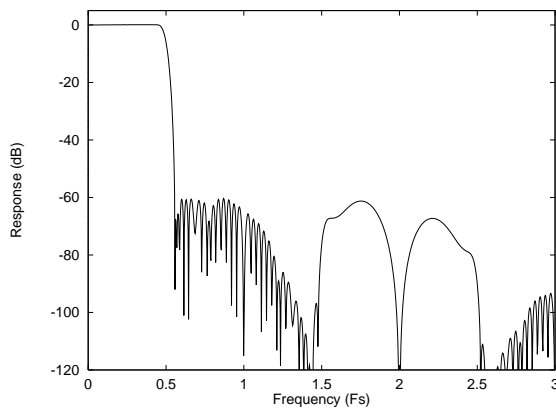


Figure 26 DAC Digital Filter Frequency Response – 44.1, 48 and 96kHz

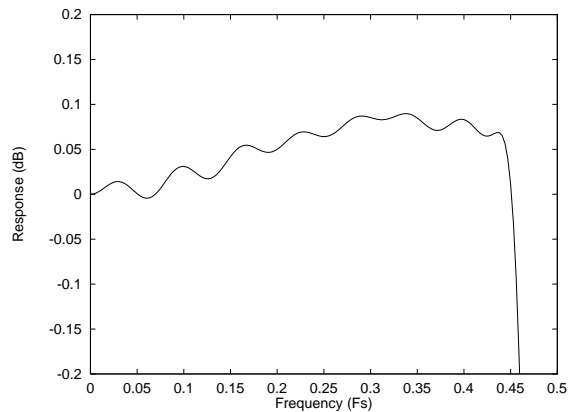


Figure 27 DAC Digital Filter Ripple – 44.1, 48 and 96kHz

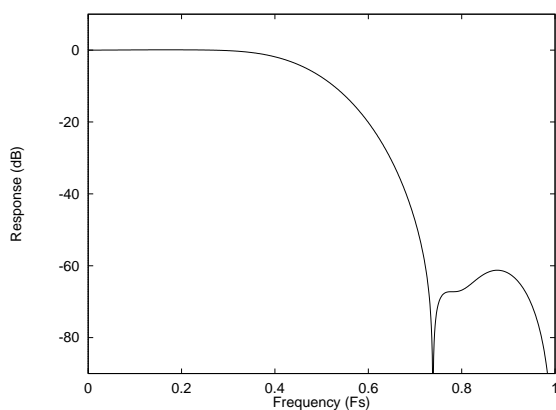


Figure 28 DAC Digital Filter Frequency Response – 192kHz

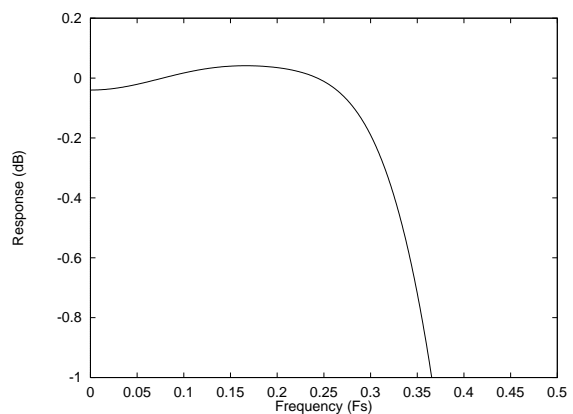
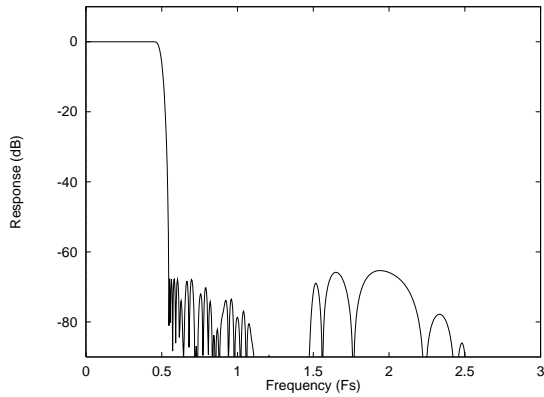
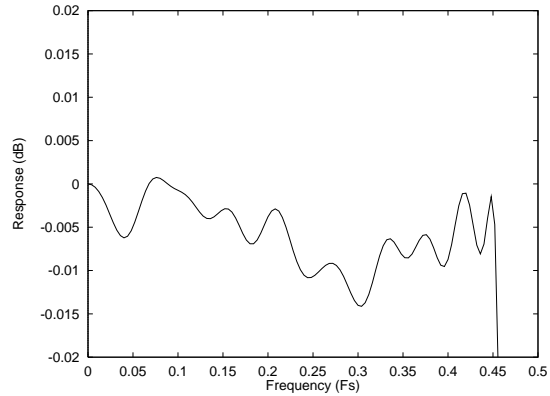


Figure 29 DAC Digital filter Ripple - 192kHz

**ADC FILTER RESPONSES**



**Figure 30 ADC Digital Filter Frequency Response**

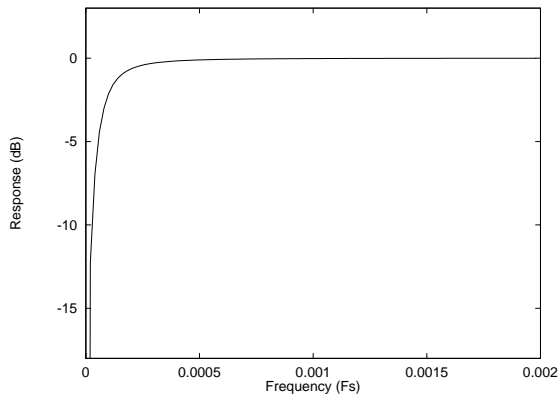


**Figure 31 ADC Digital Filter Ripple**

**ADC HIGH PASS FILTER**

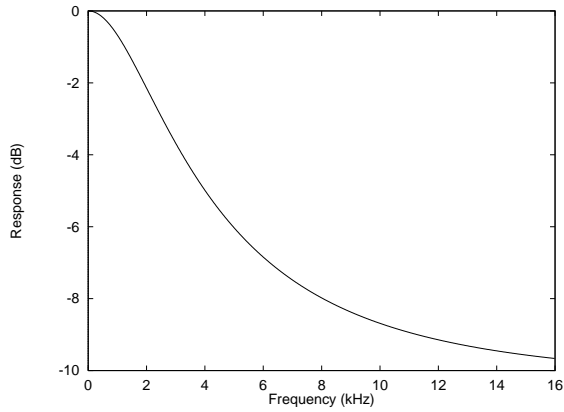
The WM8778 has a selectable digital highpass filter to remove DC offsets. The filter response is characterised by the following polynomial.

$$H(z) = \frac{1 - z^{-1}}{1 - 0.9995z^{-1}}$$

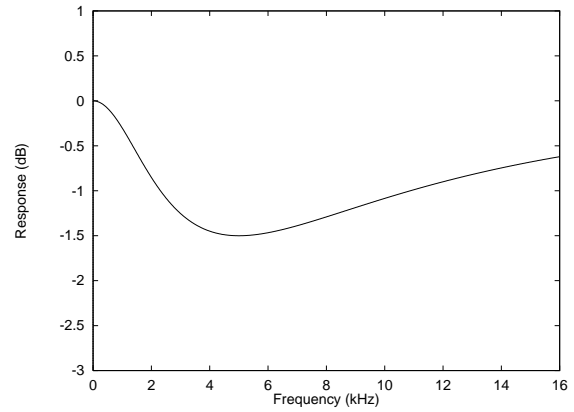


**Figure 32 ADC Highpass Filter Response**

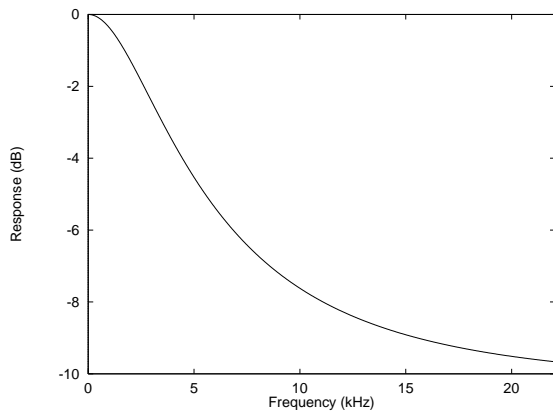
**DIGITAL DE-EMPHASIS CHARACTERISTICS**



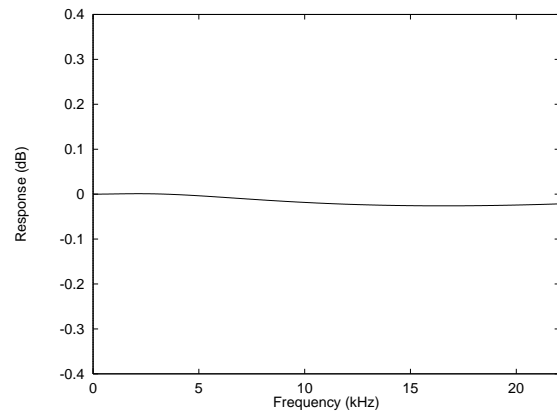
**Figure 33 De-Emphasis Frequency Response (32kHz)**



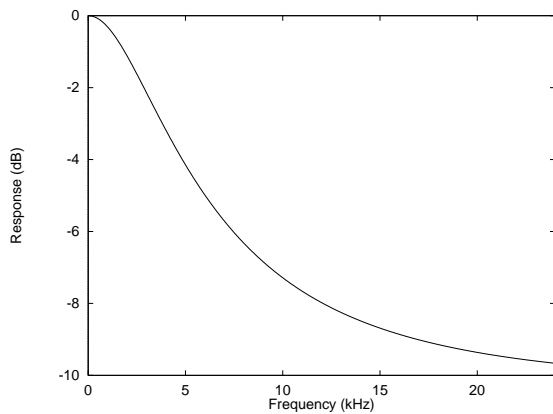
**Figure 34 De-Emphasis Error (32kHz)**



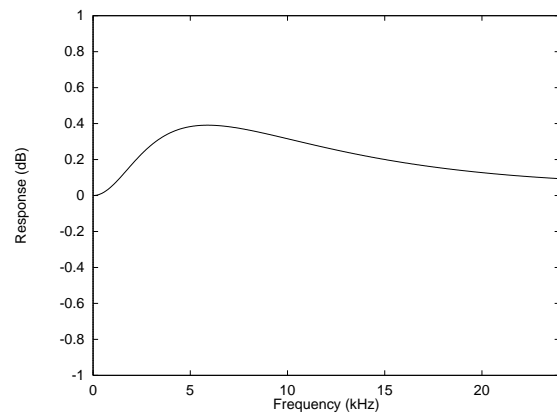
**Figure 35 De-Emphasis Frequency Response (44.1kHz)**



**Figure 36 De-Emphasis Error (44.1kHz)**



**Figure 37 De-Emphasis Frequency Response (48kHz)**



**Figure 38 De-Emphasis Error (48kHz)**

APPLICATIONS INFORMATION

RECOMMENDED EXTERNAL COMPONENTS

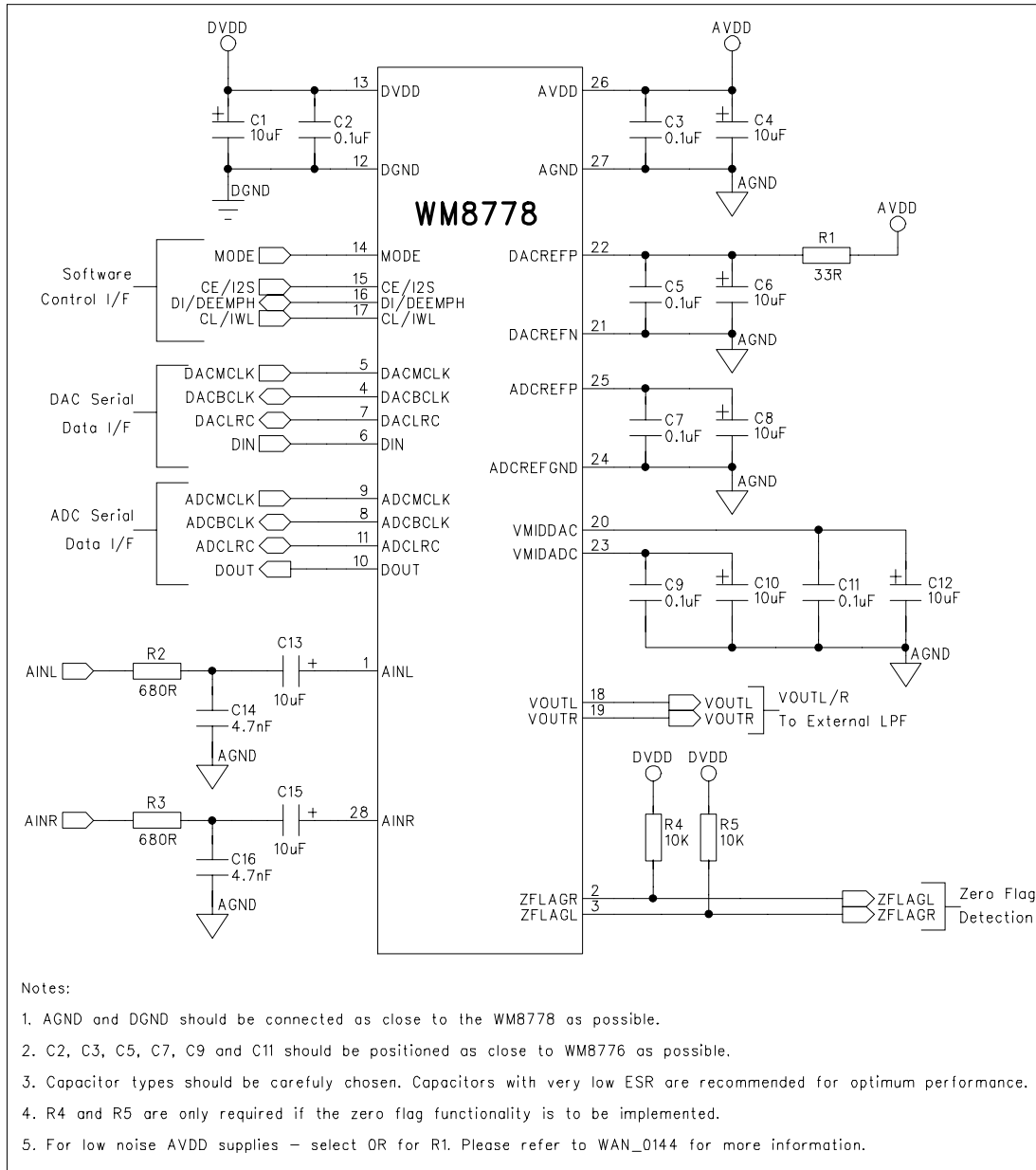


Figure 39 External Component Diagram



It is recommended that a low pass filter be applied to the output from the DAC for hi-fi applications. Typically a second order filter is suitable and provides sufficient attenuation of high frequency components (the unique low order, high bit count multi-bit sigma delta DAC structure used in WM8778 produces much less high frequency output noise). This filter is typically also used to provide the 2x gain needed to provide the standard 2Vrms output level from most consumer equipment. Figure 34 shows a suitable post DAC filter circuit, with 2x gain. Alternative inverting filter architectures might also be used with as good results.

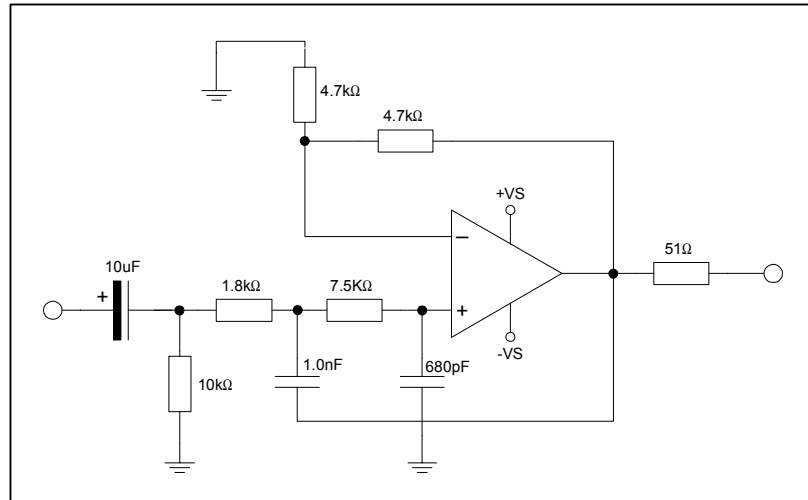
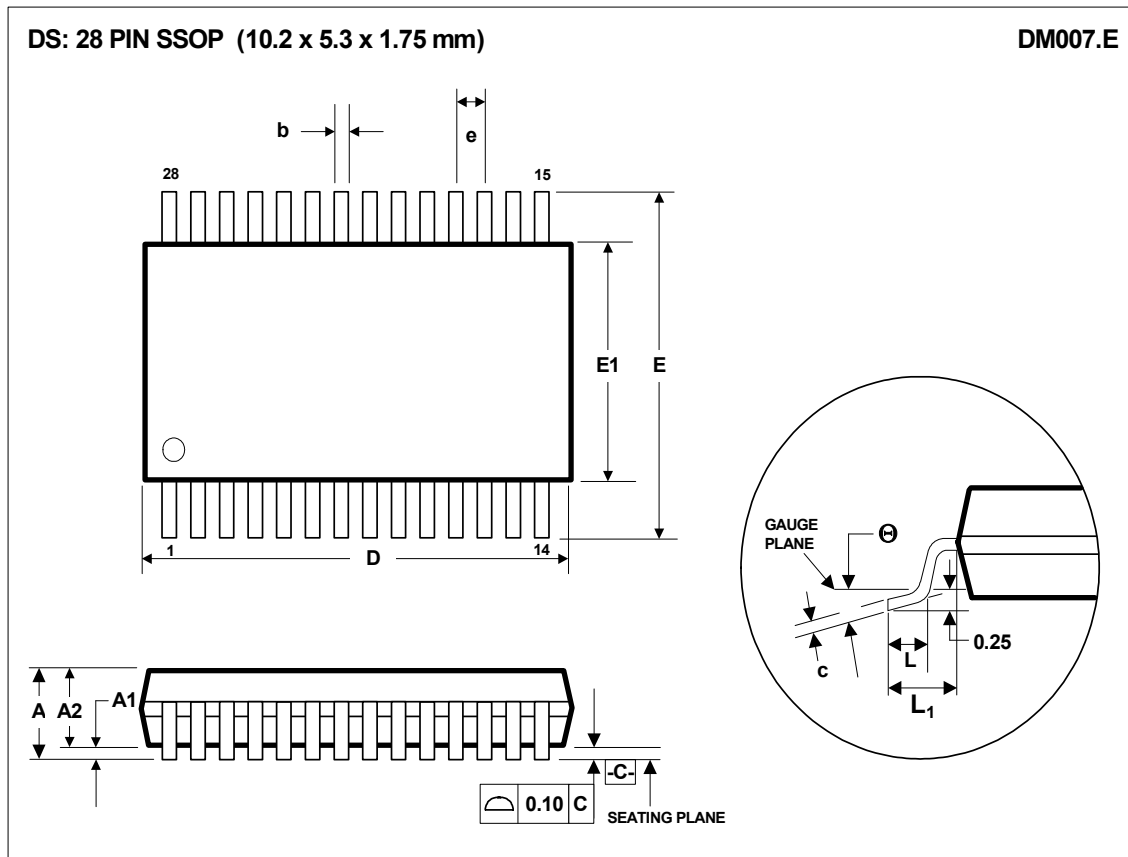


Figure 40 Recommended Post DAC Filter Circuit

PACKAGE DIMENSIONS



Symbols	Dimensions (mm)		
	MIN	NOM	MAX
<b>A</b>	-----	-----	2.0
<b>A<sub>1</sub></b>	0.05	-----	0.25
<b>A<sub>2</sub></b>	1.65	1.75	1.85
<b>b</b>	0.22	0.30	0.38
<b>c</b>	0.09	-----	0.25
<b>D</b>	9.90	10.20	10.50
<b>e</b>	0.65 BSC		
<b>E</b>	7.40	7.80	8.20
<b>E<sub>1</sub></b>	5.00	5.30	5.60
<b>L</b>	0.55	0.75	0.95
<b>L<sub>1</sub></b>	1.25 REF		
<b>θ</b>	0°	4°	8°
<b>REF:</b>	JEDEC.95, MO-150		

- NOTES:
- A. ALL LINEAR DIMENSIONS ARE IN MILLIMETERS.
  - B. THIS DRAWING IS SUBJECT TO CHANGE WITHOUT NOTICE.
  - C. BODY DIMENSIONS DO NOT INCLUDE MOLD FLASH OR PROTRUSION, NOT TO EXCEED 0.20MM.
  - D. MEETS JEDEC.95 MO-150, VARIATION = AH. REFER TO THIS SPECIFICATION FOR FURTHER DETAILS.

## IMPORTANT NOTICE

Wolfson Microelectronics plc ("Wolfson") products and services are sold subject to Wolfson's terms and conditions of sale, delivery and payment supplied at the time of order acknowledgement.

Wolfson warrants performance of its products to the specifications in effect at the date of shipment. Wolfson reserves the right to make changes to its products and specifications or to discontinue any product or service without notice. Customers should therefore obtain the latest version of relevant information from Wolfson to verify that the information is current.

Testing and other quality control techniques are utilised to the extent Wolfson deems necessary to support its warranty. Specific testing of all parameters of each device is not necessarily performed unless required by law or regulation.

In order to minimise risks associated with customer applications, the customer must use adequate design and operating safeguards to minimise inherent or procedural hazards. Wolfson is not liable for applications assistance or customer product design. The customer is solely responsible for its selection and use of Wolfson products. Wolfson is not liable for such selection or use nor for use of any circuitry other than circuitry entirely embodied in a Wolfson product.

Wolfson's products are not intended for use in life support systems, appliances, nuclear systems or systems where malfunction can reasonably be expected to result in personal injury, death or severe property or environmental damage. Any use of products by the customer for such purposes is at the customer's own risk.

Wolfson does not grant any licence (express or implied) under any patent right, copyright, mask work right or other intellectual property right of Wolfson covering or relating to any combination, machine, or process in which its products or services might be or are used. Any provision or publication of any third party's products or services does not constitute Wolfson's approval, licence, warranty or endorsement thereof. Any third party trade marks contained in this document belong to the respective third party owner.

Reproduction of information from Wolfson datasheets is permissible only if reproduction is without alteration and is accompanied by all associated copyright, proprietary and other notices (including this notice) and conditions. Wolfson is not liable for any unauthorised alteration of such information or for any reliance placed thereon.

Any representations made, warranties given, and/or liabilities accepted by any person which differ from those contained in this datasheet or in Wolfson's standard terms and conditions of sale, delivery and payment are made, given and/or accepted at that person's own risk. Wolfson is not liable for any such representations, warranties or liabilities or for any reliance placed thereon by any person.

### ADDRESS:

Wolfson Microelectronics plc  
Westfield House  
26 Westfield Road  
Edinburgh  
EH11 2QB  
United Kingdom  
Tel :: +44 (0)131 272 7000  
Fax :: +44 (0)131 272 7001  
Email :: sales@wolfsonmicro.com