

## 60MSPS 3-Channel AFE with Multiple Device Operation and Programmable Automatic Black Level Calibration

### DESCRIPTION

The WM8224 is an analogue front end/digitiser IC which processes and digitises the analogue output signals from CCD sensors or Contact Image Sensors (CIS) at pixel sample rates of up to 60MSPS.

The device includes three analogue signal processing channels each of which contains Reset Level Clamping, Correlated Double Sampling and Programmable Gain and Offset adjust functions. The output from each of these channels is time multiplexed into a single high-speed 16-bit Analogue to Digital Converter. The digital data is available in a variety of output formats via the flexible data port.

An internal 4-bit DAC is supplied for internal reference level generation. This may be used during CDS to reference CIS signals or during Clamping to clamp CCD signals. An external reference level may also be supplied. ADC references are generated internally, ensuring optimum performance from the device.

A programmable automatic Black-Level Calibration function is available to adjust the DC offset of the output data. A daisy chain feature allows multiple devices to operate together using the same control interface and output data bus.

### FEATURES

- 12 or 16-bit ADC, 40MSPS conversion rate
- 8 or 10-bit ADC, 60MSPS conversion rate
- Low power – 360 mW typical
- 3.3V single supply operation
- 3 channel operation
- Daisy Chain feature for multiple device use
- Correlated double sampling
- Programmable gain (9-bit resolution)
- Programmable offset adjust (8-bit resolution)
- Flexible clamp timing
- Programmable clamp voltage
- Internally generated voltage references
- Automatic Black Level Calibration
- 32-lead QFN package
- Serial control interface

### APPLICATIONS

- Digital Copiers
- USB2.0 compatible scanners
- Multi-function peripherals
- High-speed CCD/CIS sensor interface

### BLOCK DIAGRAM

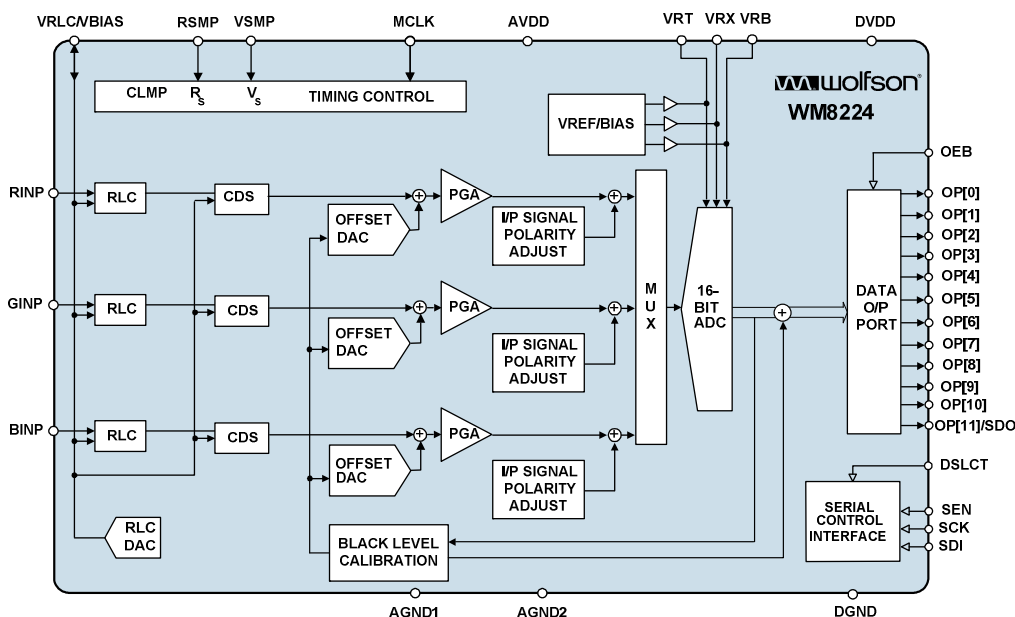

---

**TABLE OF CONTENTS**

<b>DESCRIPTION</b> .....	<b>1</b>
<b>FEATURES</b> .....	<b>1</b>
<b>APPLICATIONS</b> .....	<b>1</b>
<b>BLOCK DIAGRAM</b> .....	<b>1</b>
<b>TABLE OF CONTENTS</b> .....	<b>2</b>
<b>PIN CONFIGURATION</b> .....	<b>4</b>
<b>ORDERING INFORMATION</b> .....	<b>4</b>
<b>PIN DESCRIPTION</b> .....	<b>5</b>
<b>ABSOLUTE MAXIMUM RATINGS</b> .....	<b>6</b>
<b>RECOMMENDED OPERATING CONDITIONS</b> .....	<b>6</b>
<b>THERMAL PERFORMANCE</b> .....	<b>6</b>
<b>ELECTRICAL CHARACTERISTICS</b> .....	<b>7</b>
40MHZ OPERATION.....	7
60MHZ OPERATION.....	7
GENERAL CHARACTERISTICS .....	9
INPUT VIDEO SAMPLING .....	11
CDS MODE (CDS=1) .....	11
NON-CDS MODE (CDS=0) .....	12
OUTPUT DATA TIMING.....	14
SERIAL INTERFACE.....	15
<b>INTERNAL POWER ON RESET CIRCUIT</b> .....	<b>16</b>
<b>DEVICE DESCRIPTION</b> .....	<b>18</b>
INTRODUCTION.....	18
CONFIGURABLE RESOLUTION OF ADC.....	18
INPUT SAMPLING .....	18
RESET LEVEL CLAMPING (RLC).....	19
CDS/NON-CDS PROCESSING.....	21
OFFSET ADJUST AND PROGRAMMABLE GAIN .....	21
ADC INPUT BLACK LEVEL ADJUST .....	22
OVERALL SIGNAL FLOW SUMMARY.....	23
CALCULATING THE OUTPUT CODE FOR A GIVEN INPUT .....	24
OUTPUT FORMATS .....	25
PROGRAMMABLE AUTOMATIC BLACK LEVEL CALIBRATION .....	26
INDICATING THE START OF A BLC PROCEDURE .....	27
BLC DURATION CONTROL .....	28
BLC WORKED EXAMPLE:.....	29
BLC SCENARIOS OF OPERATION.....	31
REFERENCES .....	35
POWER MANAGEMENT .....	35
CONTROL INTERFACE.....	35
MULTIPLE DEVICE OPERATION .....	36
OPERATING MODES .....	39
16 BIT MODE .....	39
10 BIT MODE .....	40
<b>DEVICE CONFIGURATION</b> .....	<b>41</b>
REGISTER MAP .....	41
REGISTER MAP DESCRIPTION .....	42
<b>APPLICATIONS INFORMATION</b> .....	<b>47</b>
RECOMMENDED EXTERNAL COMPONENTS.....	47
RECOMMENDED EXTERNAL COMPONENT VALUES .....	47

---

<b>PACKAGE DIMENSIONS .....</b>	<b>48</b>
<b>IMPORTANT NOTICE .....</b>	<b>49</b>
ADDRESS: .....	49

### PIN CONFIGURATION

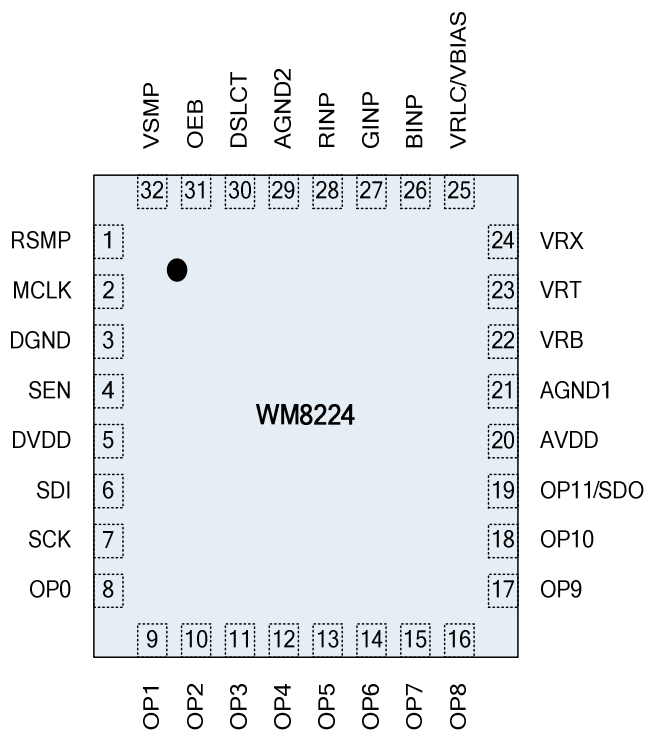

### ORDERING INFORMATION

DEVICE	TEMPERATURE RANGE	PACKAGE	MOISTURE SENSITIVITY LEVEL	PEAK SOLDERING TEMPERATURE
WM8224SEFL	0 to 70°C	32-lead QFN (5x5x0.9mm) (Pb-free)	MSL1	260°C
WM8224SEFL/R	0 to 70°C	32-lead QFN (5x5x0.9mm) (Pb-free, tape and reel)	MSL1	260°C

**Note:**

Reel quantity = 3,500

## PIN DESCRIPTION

PIN	NAME	TYPE	DESCRIPTION
1	RSMP	Digital input	Reset sample pulse (when CDS=1) or clamp control.
2	MCLK	Digital input	Master (ADC) clock. This clock determines the ADC conversion rate.
3	DGND	Supply	Digital ground.
4	SEN	Digital input	Enables the serial interface when high.
5	DVDD	Supply	Digital supply for logic, clock generator and digital input/output pads.
6	SDI	Digital input	Serial interface data input.
7	SCK	Digital input	Serial interface clock.
			Digital output data bus. ADC output data (d15:d0) is available in a variety of output formats.
8	OP[0]	Digital output	d0 (LSB)
9	OP[1]	Digital output	d1
10	OP[2]	Digital output	d2
11	OP[3]	Digital output	d3
12	OP[4]	Digital output	d4
13	OP[5]	Digital output	d5
14	OP[6]	Digital output	d6
15	OP[7]	Digital output	d7
16	OP[8]	Digital output	d8
17	OP[9]	Digital output	d9
18	OP[10]	Digital output	d10
19	OP[11]/SDO	Digital output	d11 (MSB) Alternatively, pin OP[11]/SDO may be used to output register read-back data. See Serial Interface description in Device Description section for further details.
20	AVDD	Supply	Analogue supply. This must be operated at the same potential as DVDD.
21	AGND1	Supply	Analogue ground.
22	VRB	Analogue output	Lower reference voltage. This pin must be connected to AGND via a decoupling capacitor.
23	VRT	Analogue output	Upper reference voltage. This pin must be connected to AGND via a decoupling capacitor.
24	VRX	Analogue output	Input return bias voltage. This pin must be connected to AGND via a decoupling capacitor.
25	VRLC/VBIAS	Analogue I/O	Selectable analogue output voltage for RLC or single-ended bias reference. This pin would typically be connected to AGND via a decoupling capacitor. VRLC can be externally driven if programmed Hi-Z.
26	BINP	Analogue input	Blue channel input video.
27	GINP	Analogue input	Green channel input video.
28	RINP	Analogue input	Red channel input video.
29	AGND2	Supply	Analogue ground.
30	DSLCT	Digital Tristate Input	Sets 2-bit device ID for daisy chain operation: 0 = Device ID is 00 1 = Device ID is 01 Z = Device ID is 10
31	OEB	Digital input	Output Hi-Z control. All digital outputs set to high-impedance state when input pin OEB=1, if AUTOZ=0. Note that readback function will override high-impedance on OP11 <b>This pin has an internal 100kΩ pull-down resistor to AGND.</b>
32	VSMP	Digital input	Video sample pulse.

## ABSOLUTE MAXIMUM RATINGS

Absolute Maximum Ratings are stress ratings only. Permanent damage to the device may be caused by continuously operating at or beyond these limits. Device functional operating limits and guaranteed performance specifications are given under Electrical Characteristics at the test conditions specified.



ESD Sensitive Device. This device is manufactured on a CMOS process. It is therefore generically susceptible to damage from excessive static voltages. Proper ESD precautions must be taken during handling and storage of this device.

Wolfson tests its package types according to IPC/JEDEC J-STD-020B for Moisture Sensitivity to determine acceptable storage conditions prior to surface mount assembly. These levels are:

MSL1 = unlimited floor life at <30°C / 85% Relative Humidity. Not normally stored in moisture barrier bag.

MSL2 = out of bag storage for 1 year at <30°C / 60% Relative Humidity. Supplied in moisture barrier bag.

MSL3 = out of bag storage for 168 hours at <30°C / 60% Relative Humidity. Supplied in moisture barrier bag.

The Moisture Sensitivity Level for each package type is specified in Ordering Information.

CONDITION	MIN	MAX
Analogue supply voltage: AVDD	GND - 0.3V	GND + 5V
Digital supply voltage: DVDD	GND - 0.3V	GND + 5V
Digital ground: DGND	GND - 0.3V	GND + 0.3V
Analogue grounds: AGND1 – 2	GND - 0.3V	GND + 0.3V
Analogue inputs (RINP, GINP, BINP)	GND - 0.3V	AVDD + 0.3V
Other Analogue pins	GND - 0.3V	AVDD + 0.3V
Digital I/O pins	GND - 0.3V	DVDD + 0.3V
Operating temperature range: T <sub>A</sub>	0°C	+70°C
Storage temperature prior to soldering	30°C max / 85% RH max	
Storage temperature after soldering	-65°C	+150°C

### Notes:

1. GND denotes the voltage of any ground pin.
2. AGND1, AGND2 and DGND pins are intended to be operated at the same potential. Differential voltages between these pins will degrade performance.

## RECOMMENDED OPERATING CONDITIONS

CONDITION	SYMBOL	MIN	TYP	MAX	UNITS
Operating temperature range	T <sub>A</sub>	0		70	°C
Analogue supply voltage	AVDD	2.97	3.3	3.63	V
Digital core and I/O supply voltage	DVDD	2.97	3.3	3.63	V

## THERMAL PERFORMANCE

PARAMETER	SYMBOL	TEST CONDITIONS	MIN	TYP	MAX	UNIT
<b>Performance</b>						
Thermal resistance – junction to case	R <sub>θJC</sub>	T <sub>ambient</sub> = 25°C		10.27		°C/W
Thermal resistance – junction to ambient	R <sub>θJA</sub>			29.45		°C/W

### Notes:

Figure 3 Figures given are for package mounted on 4-layer FR4 according to JESD51-5 and JESD51-7.

## ELECTRICAL CHARACTERISTICS

### 40MHZ OPERATION

#### Test Conditions

AVDD = DVDD = 3.3V, AGND = DGND = 0V, T<sub>A</sub> = 25°C, MCLK = 40MHz unless otherwise stated.

PARAMETER	SYMBOL	TEST CONDITIONS	MIN	TYP	MAX	UNIT
<b>Overall System Specification (including 16-bit ADC, PGA, Offset and CDS functions)</b>						
Max Conversion rate				40		MSPS
Full-scale input voltage range (see Note 1)		LOWREFS=0, Max Gain		0.25		Vp-p
		LOWREFS=0, Min Gain		3.03		Vp-p
		LOWREFS=1, Max Gain		0.15		Vp-p
		LOWREFS=1, Min Gain		1.82		Vp-p
Input signal limits (see Note 2)	V <sub>IN</sub>	FOL_EN=0	AGND-0.3		AVDD+0.3	V
		FOL_EN=1, minimum		AGND		V
		FOL_EN=1, maximum		AGND+1.2		V
Input capacitance	C <sub>IN</sub>	RINP, GINP, BINP to AGND		10		pF
Full-scale transition error		Gain = 0dB; PGA[8:0] = 18(hex)		20		mV
Zero-scale transition error		Gain = 0dB; PGA[8:0] = 18(hex)		20		mV
Differential non-linearity	DNL	16-bit		1.2		LSB
Integral non-linearity (pk-pk/2)	INL	16-bit		56		LSB
Channel to channel gain matching				1.3		%
Output noise		Unity Gain (Unused channels grounded)		10.2		LSB rms
<b>Programmable Gain Amplifier</b>						
Resolution				9		bits
Gain				$0.66 + \frac{7.34}{511} * PGA[8:0]$		V/V
Max gain, each channel	G <sub>MAX</sub>			8		V/V
Min gain, each channel	G <sub>MIN</sub>			0.66		V/V
<b>Analogue to Digital Converter</b>						
Resolution				16		bits
Speed				40		MSPS
Full-scale input range (2*(VRT-VRB))		LOWREFS=0		2		V
		LOWREFS=1		1.2		V

### 60MHZ OPERATION

#### Test Conditions

AVDD = DVDD = 3.3V, AGND = DGND = 0V, T<sub>A</sub> = 25°C, MCLK = 60MHz unless otherwise stated.

PARAMETER	SYMBOL	TEST CONDITIONS	MIN	TYP	MAX	UNIT
<b>Overall System Specification (including 10-bit ADC, PGA, Offset and CDS functions)</b>						
Max Conversion rate				60		MSPS
Full-scale input voltage range (see Note 1)		LOWREFS=0, Max Gain		0.26		Vp-p
		LOWREFS=0, Min Gain		3.03		Vp-p
		LOWREFS=1, Max Gain		0.16		Vp-p
		LOWREFS=1, Min Gain		1.82		Vp-p
Input signal limits (see Note 2)	V <sub>IN</sub>	FOL_EN=0	AGND-0.3		AVDD+0.3	V
		FOL_EN=1, minimum		AGND		V
		FOL_EN=1, maximum		AGND+1.2		V
Input capacitance	C <sub>IN</sub>	RINP, GINP, BINP to AGND		10		pF
Full-scale transition error		Gain = 0dB; PGA[8:0] = 18(hex)		20		mV

**Test Conditions**AVDD = DVDD = 3.3V, AGND = DGND = 0V, T<sub>A</sub> = 25°C, MCLK = 60MHz unless otherwise stated.

PARAMETER	SYMBOL	TEST CONDITIONS	MIN	TYP	MAX	UNIT
Zero-scale transition error		Gain = 0dB; PGA[8:0] = 18(hex)		20		mV
Differential non-linearity	DNL	10-bit		0.5		LSB
Integral non-linearity (pk-pk/2)	INL	10-bit		7		LSB
Channel to channel gain matching				2.5		%
Output noise		Unity Gain 10-bit (Unused channels grounded)		0.5		LSB rms
<b>Programmable Gain Amplifier</b>						
Resolution				9		bits
Gain				$0.66 + \frac{7.34}{511} * PGA[8:0]$		V/V
Max gain, each channel	G <sub>MAX</sub>			7.7		V/V
Min gain, each channel	G <sub>MIN</sub>			0.65		V/V
<b>Analogue to Digital Converter</b>						
Resolution				10		bits
Speed				60		MSPS
Full-scale input range (2*(VRT-VRB))		LOWREFS=0		2		V
		LOWREFS=1		1.2		V

**Notes:**

- Full-scale input voltage** denotes the differential input signal amplitude (V<sub>IN</sub>-V<sub>R1C</sub> in non-CDS mode, V<sub>IN</sub>-RESET level in CDS mode) that can be gained to match the ADC full-scale input range.
- Input signal limits** are the limits within which each input voltage and V<sub>R1C</sub> reference must lie.



## GENERAL CHARACTERISTICS

## Test Conditions

AVDD = DVDD = 3.3V, AGND = DGND = 0V, T<sub>A</sub> = 25°C

PARAMETER	SYMBOL	TEST CONDITIONS	MIN	TYP	MAX	UNIT
<b>References</b>						
Upper reference voltage	VRT	LOWREFS=0		2.05		V
		LOWREFS=1		1.85		V
Lower reference voltage	VRB	LOWREFS=0		1.05		V
		LOWREFS=1		1.25		V
Input return bias voltage	VRX			1.25		V
Diff. Reference voltage (VRT-VRB)	V <sub>RTB</sub>	LOWREFS=0		1.0		V
		LOWREFS=1		0.6		V
Output resistance VRT, VRB, VRX				1		Ω
<b>VRLC/Reset-Level Clamp (RLC)</b>						
RLC switching impedance				50		Ω
VRLC short-circuit current				2		mA
VRLC output resistance				2		Ω
VRLC Hi-Z leakage current		VRLC = 0 to AVDD			1	μA
RLCDAC resolution				4		bits
RLCDAC step size	V <sub>RLCSTEP</sub>	RLCDACRNG=0,		0.173		V/step
	V <sub>RLCSTEP</sub>	RLCDACRNG=1, LOWREFS=0		0.11		V/step
	V <sub>RLCSTEP</sub>	RLCDACRNG=1, LOWREFS=1		0.097		V/step
RLCDAC output voltage at code 0(hex)	V <sub>RLCBOT</sub>	RLCDACRNG=0, RLCDAC[3:0]=0000,		0.4		V
	V <sub>RLCBOT</sub>	RLCDACRNG=1, RLCDAC[3:0]=0000,		0.4		V
RLCDAC output voltage at code F(hex)	V <sub>RLCTOP</sub>	RLCDACRNG=0, RLCDAC[3:0]=1111,		3.0		V
	V <sub>RLCTOP</sub>	RLCDACRNG=1, RLCDAC[3:0]=1111, LOWREFS = 0		2.05		V
	V <sub>RLCTOP</sub>	RLCDACRNG=1, RLCDAC[3:0]=1111, LOWREFS = 1		1.85		V
VRLC DNL			-0.5		+0.5	LSB
VRLC INL			-0.5		+0.5	LSB
<b>Offset DAC, Monotonicity Guaranteed</b>						
Resolution				8		bits
Differential non-linearity	DNL			0.1	0.5	LSB
Integral non-linearity	INL			0.75	1	LSB
Step size				2.04		mV/step
Output voltage		Code 00(hex)		-250		mV
		Code FF(hex)		+250		mV
<b>DIGITAL SPECIFICATIONS</b>						
<b>Digital Inputs</b>						
High level input voltage	V <sub>IH</sub>		0.7 * DVDD			V
Low level input voltage	V <sub>IL</sub>				0.2 * DVDD	V
High level input current	I <sub>IH</sub>				1	μA
Low level input current	I <sub>IL</sub>				1	μA
Input capacitance	C <sub>I</sub>			5		pF

**Test Conditions**AVDD = DVDD = 3.3V, AGND = DGND = 0V, T<sub>A</sub> = 25°C

PARAMETER	SYMBOL	TEST CONDITIONS	MIN	TYP	MAX	UNIT
<b>Digital Outputs</b>						
High level output voltage	V <sub>OH</sub>	I <sub>OH</sub> = 1mA	DVDD - 0.5			V
Low level output voltage	V <sub>OL</sub>	I <sub>OL</sub> = 1mA			0.5	V
High impedance output current	I <sub>OZ</sub>				1	μA
<b>Digital IO Pins</b>						
Applied high level input voltage	V <sub>IH</sub>		0.7 * DVDD			V
Applied low level input voltage	V <sub>IL</sub>				0.2 * DVDD	V
High level output voltage	V <sub>OH</sub>	I <sub>OH</sub> = 1mA	DVDD - 0.5			V
Low level output voltage	V <sub>OL</sub>	I <sub>OL</sub> = 1mA			0.5	V
Low level input current	I <sub>IL</sub>				1	μA
High level input current	I <sub>IH</sub>				1	μA
Input capacitance	C <sub>I</sub>			5		pF
Output Impedance	R <sub>O</sub>	I <sub>O</sub> = 1mA		38		Ω
High impedance output current	I <sub>OZ</sub>				1	μA
<b>Supply Currents</b>						
Analogue supply current – active		FOL_EN=0		93		mA
		FOL_EN=1		141		mA
Digital supply current – active		FOL_EN=0		7.3		mA
		FOL_EN=1		8		mA
Total supply current – active		FOL_EN=0		100.3		mA
		FOL_EN=1		149		mA
Total supply current – full power down mode				150	200	μA

**INPUT VIDEO SAMPLING**

**CDS MODE (CDS=1)**

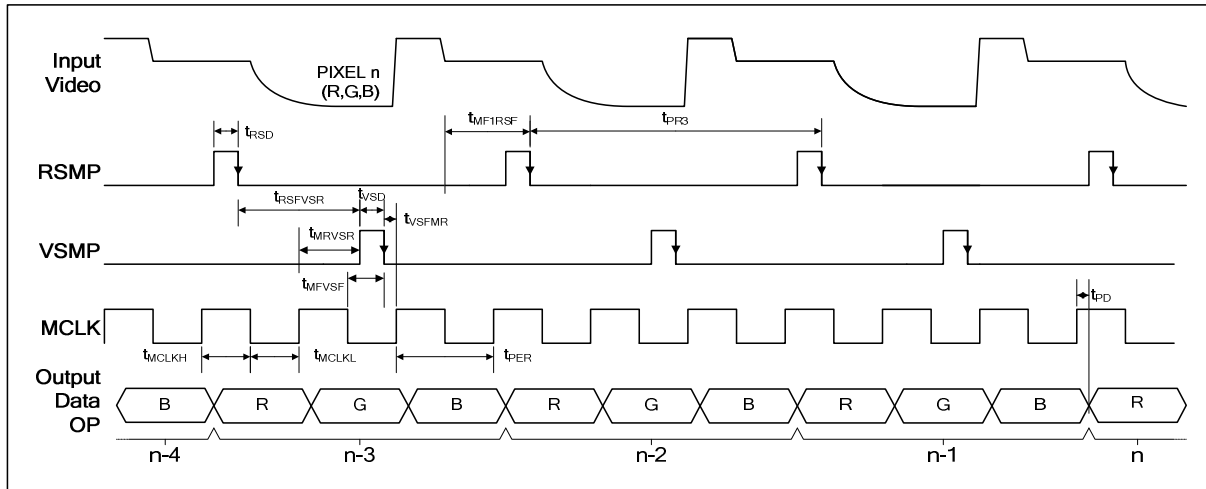

Figure 1 Three-channel CDS Operation (CDS=1)

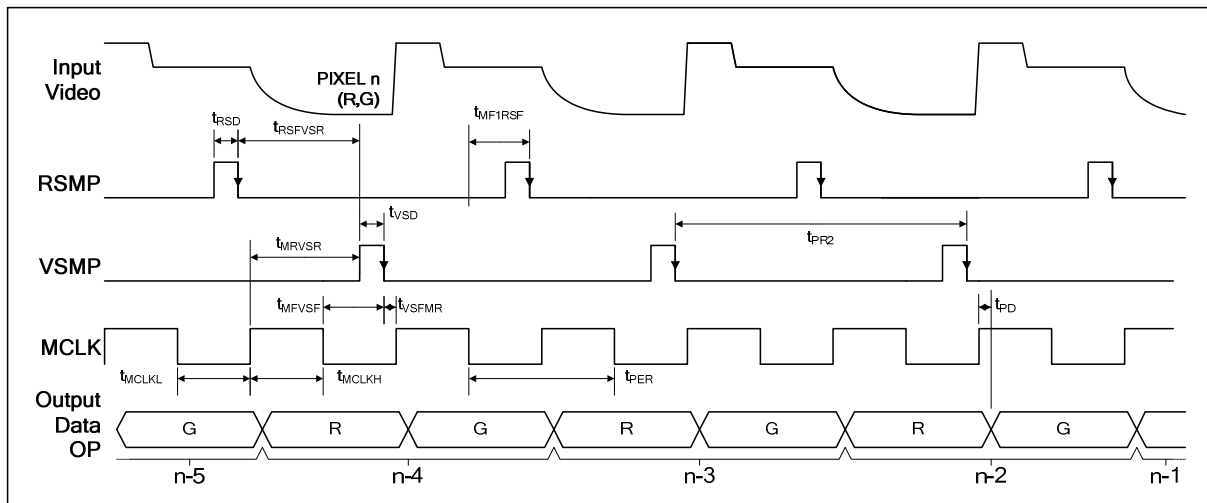

Figure 2 Two-channel CDS Operation (CDS=1)

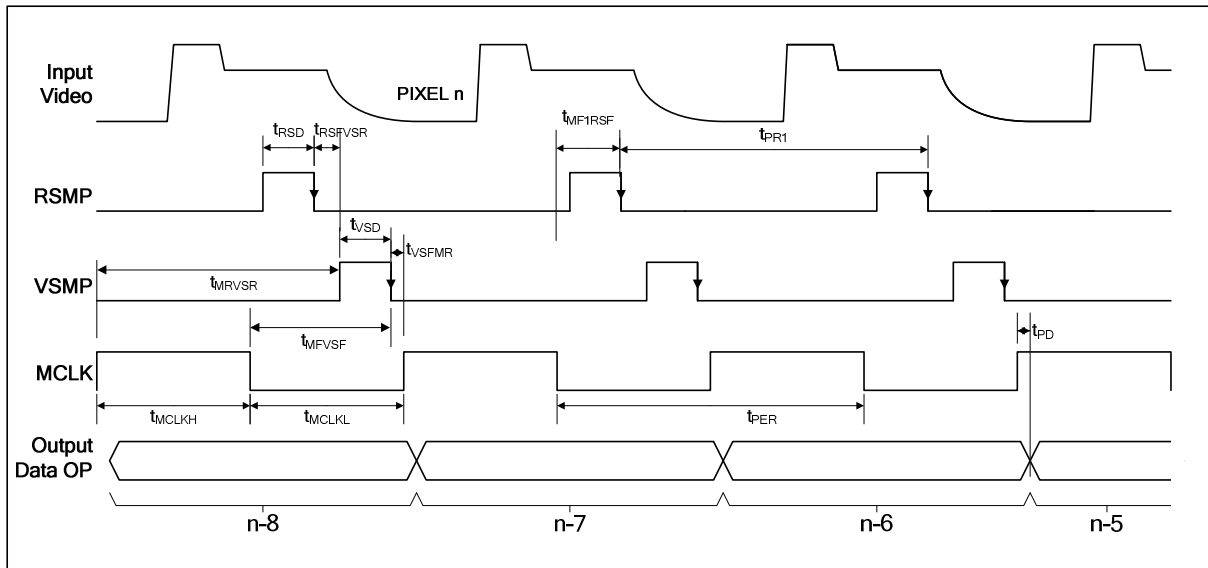

Figure 3 One-channel CDS Operation (CDS=1)

Notes:

1. The relationship between input video signal and sample points is controlled by VSMP and RSMP.
2. When VSMP is high the input video signal is connected to the Video sampling capacitors.
3. When RSMP is high the input video signal is connected to the Reset sampling capacitors.
4. Non-CDS operation is also possible; VSMP, MCLK timing is unchanged, RSMP is not required in this mode but can be used to control input clamping.

NON-CDS MODE (CDS=0)

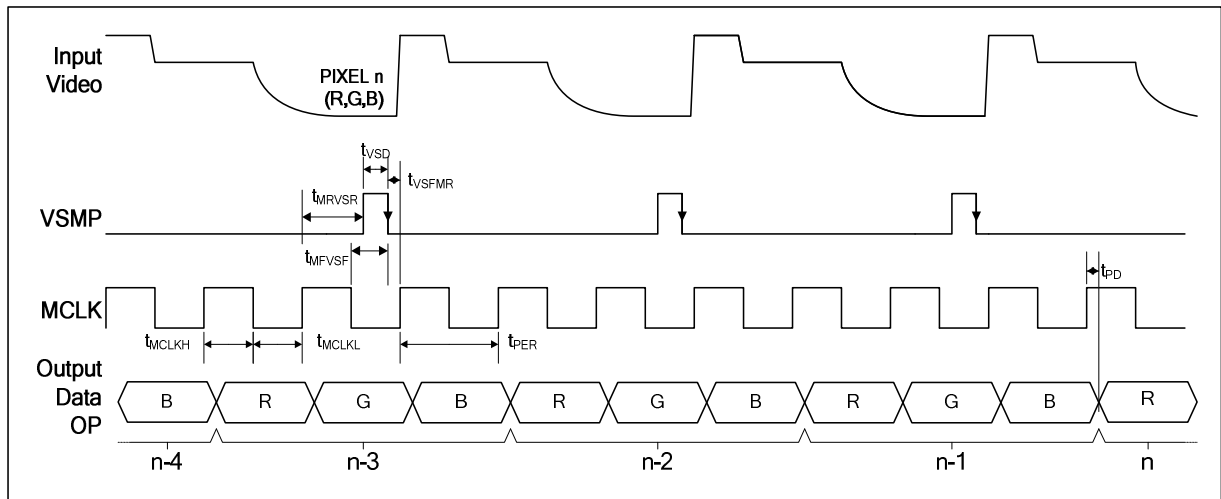

Figure 4 Three-channel non-CDS Operation (CDS=0)

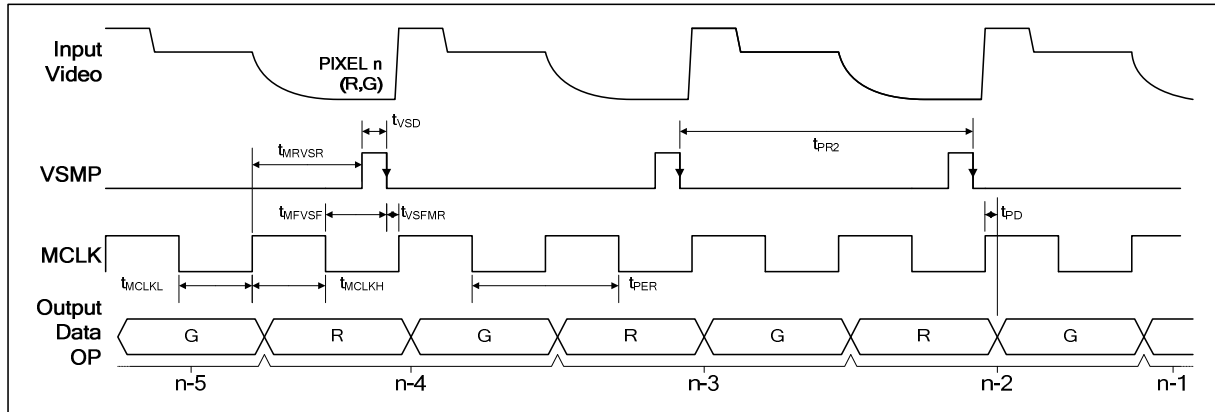

Figure 5 Two-channel non-CDS Operation (CDS=0)

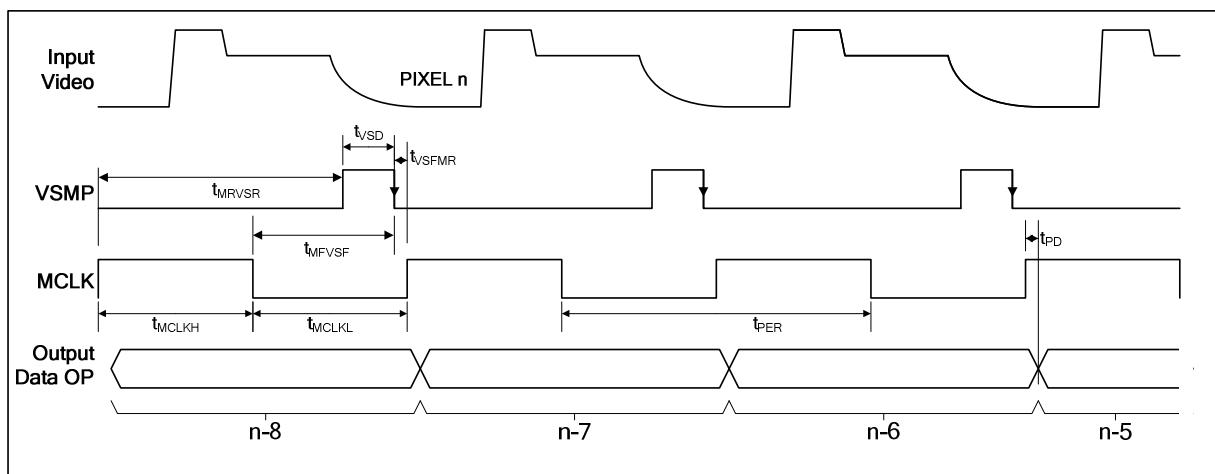

Figure 6 One-channel non-CDS Operation (CDS=0)

Notes:

1. The relationship between input video signal and sample points is controlled by VSMP and RSMP.
2. When VSMP is high the input video signal is connected to the Video sampling capacitors and VRCL is connected to the Reset sampling capacitors.
3. RSMP is not required in this mode but can be used to control input clamping.

**Test Conditions**

AVDD = DVDD = 3.3V, AGND = DGND = 0V, T<sub>A</sub> = 25°C.

PARAMETER	SYMBOL	TEST CONDITIONS	MIN	TYP	MAX	UNITS
MCLK period, ACLKDIV=00 (default)	t <sub>PER</sub>	12 or 16 bit	25			ns
	t <sub>PER</sub>	8 or 10 bit	16.67			ns
MCLK high period	t <sub>MCLKH</sub>			0.5		MCLK periods
MCLK low period	t <sub>MCLKL</sub>			0.5		MCLK periods
MCLK Duty Cycle			45:55		55:45	%
RSMP pulse high time	t <sub>RS</sub>		3			ns
VSMP pulse high time	t <sub>VS</sub>		2			ns
RSMP falling to VSMP rising time	t <sub>RSFVSR</sub>		0			ns
MCLK rising to VSMP rising time	t <sub>MRVSR</sub>		3			ns
MCLK falling to VSMP falling time	t <sub>MFVSF</sub>		7			ns
VSMP falling to MCLK rising time	t <sub>VSFMR</sub>		0			ns
1 <sup>st</sup> MCLK falling edge after VSMP falling to RSMP falling time	t <sub>MF1RSF</sub>		7			ns
3-channel mode pixel period	t <sub>PR3</sub>		3			MCLK periods
2-channel mode pixel period	t <sub>PR2</sub>		2			MCLK periods
1-channel mode pixel period	t <sub>PR1</sub>		1			MCLK periods
Output latency. From 1 <sup>st</sup> rising edge of MCLK after VSMP falling to data output	LAT	OPDEL[3:0]=0000, ACLKDIV=00		7		MCLK periods

**Notes:**

- Parameters are measured at 50% of the rising/falling edge.

**OUTPUT DATA TIMING**

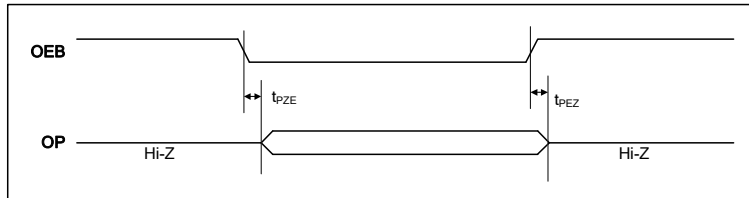

Figure 7 Output Enable/Disable Timing from OEB Pin

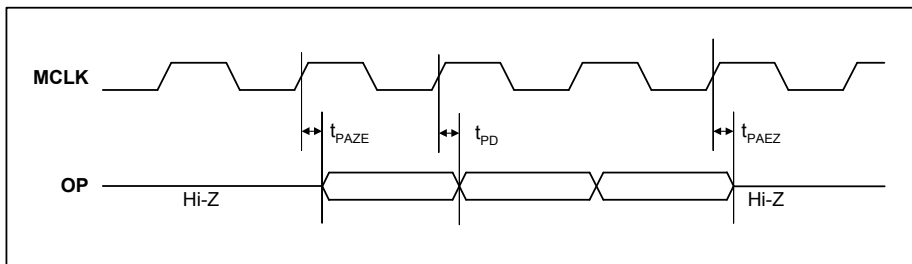
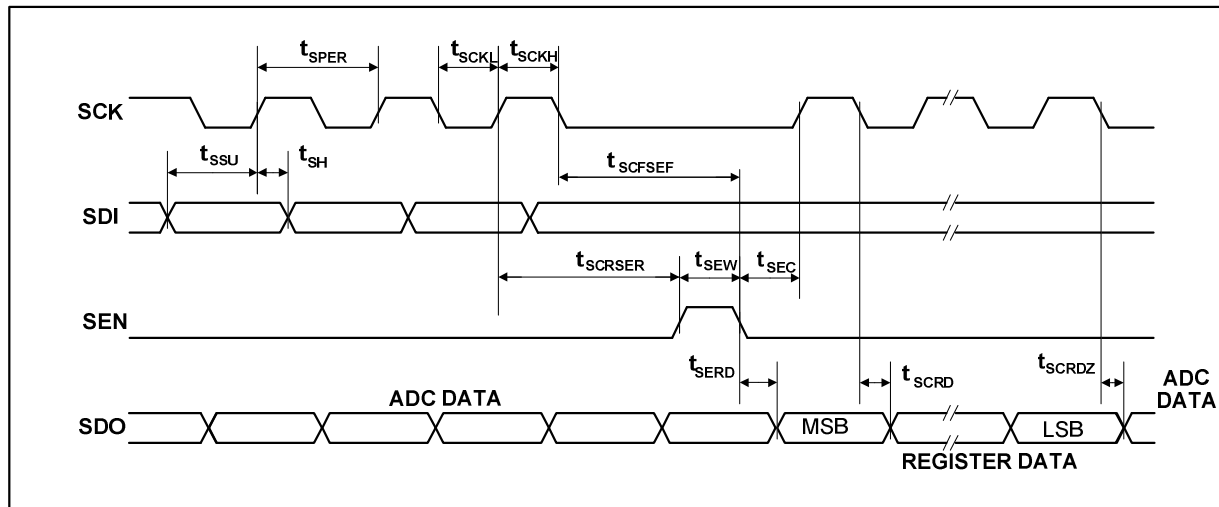

Figure 8 Output Enable/Disable Timing with AUTOZ=1

**Test Conditions**AVDD = DVDD = 3.3V, AGND = DGND = 0V, T<sub>A</sub> = 25°C, MCLK = 40MHz unless otherwise stated..

PARAMETER	SYMBOL	TEST CONDITIONS	MIN	TYP	MAX	UNITS
Output propagation delay	t <sub>PD</sub>	I <sub>OH</sub> & I <sub>OL</sub> = 1mA AUTOZ=0	3	4.5	7	ns
Output enable time, from OEB falling edge	t <sub>PZE</sub>			5		ns
Output disable time, from OEB rising edge.	t <sub>PEZ</sub>			3		ns
Automatic output enable time from MCLK rising edge.	t <sub>PAZE</sub>	AUTOZ=1, OEDEL=01		5.5		ns
Automatic output disable time from MCLK rising edge.	t <sub>PAEZ</sub>	AUTOZ=1, all OEDEL settings		3		ns

**SERIAL INTERFACE****Figure 9 Serial Interface Timing****Test Conditions**AVDD = DVDD = 3.3V, AGND = DGND = 0V, T<sub>A</sub> = 25°C, unless otherwise stated.

PARAMETER	SYMBOL	TEST CONDITIONS	MIN	TYP	MAX	UNITS
SCK period	t <sub>SPER</sub>		83.3			ns
SCK high	t <sub>SCKH</sub>		37.5			ns
SCK low	t <sub>SCKL</sub>		37.5			ns
SDI set-up time	t <sub>SSU</sub>		6			ns
SDI hold time	t <sub>SH</sub>		6			ns
SCK Rising to SEN Rising	t <sub>SCRSER</sub>		37.5			ns
SCK Falling to SEN Falling	t <sub>SCFSEF</sub>		12			ns
SEN to SCK set-up time	t <sub>SEC</sub>		12			ns
SEN pulse width	t <sub>SEW</sub>		60			ns
SEN low to SDO = Register data	t <sub>SERD</sub>				30	ns
SCK low to SDO = Register data	t <sub>SCRD</sub>				30	ns
SCK low to SDO = ADC data	t <sub>SCRDZ</sub>				30	ns

**Note:**

Figure 3 Parameters are measured at 50% of the rising/falling edge

### INTERNAL POWER ON RESET CIRCUIT

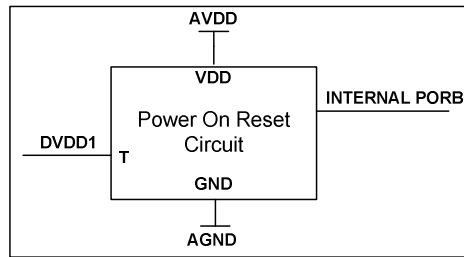

**Figure 10 Internal Power On Reset Circuit Schematic**

The WM8224 includes an internal Power-On-Reset Circuit, as shown in Figure 10, which is used to reset the digital logic into a default state after power up. The POR circuit is powered from AVDD and monitors DVDD. It asserts PORB low if AVDD or DVDD is below a minimum threshold.

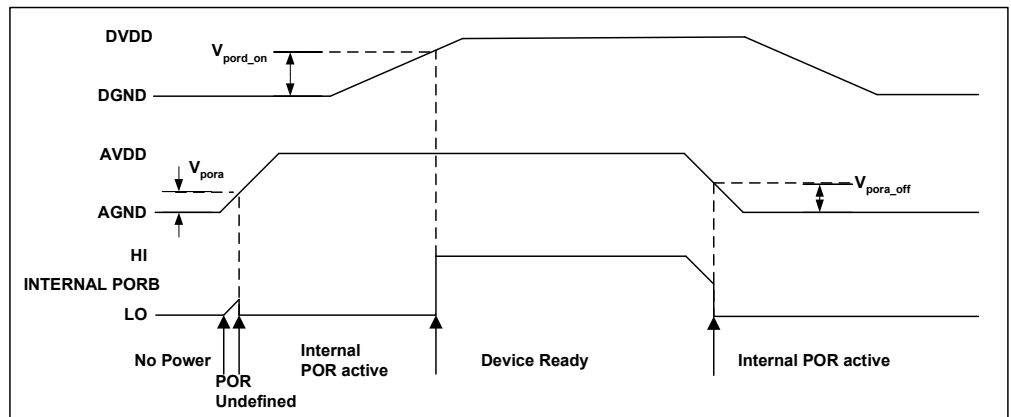

**Figure 11 Typical Power up Sequence where AVDD is Powered before DVDD**

Figure 11 shows a typical power-up sequence where AVDD is powered up first. When AVDD rises above the minimum threshold,  $V_{pora}$ , there is enough voltage for the circuit to guarantee PORB is asserted low and the chip is held in reset. In this condition, all writes to the control interface are ignored. Now AVDD is at full supply level. Next DVDD rises to  $V_{pord\_on}$  and PORB is released high and all registers are in their default state and writes to the control interface may take place.

On power down, where AVDD falls first, PORB is asserted low whenever AVDD drops below the minimum threshold  $V_{pora\_off}$ .

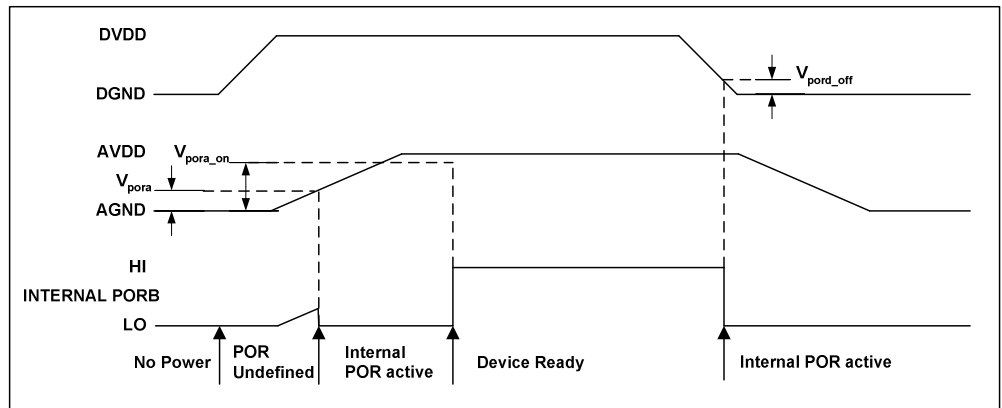

**Figure 12 Typical Power up Sequence where DVDD is Powered before AVDD**



Figure 12 shows a typical power-up sequence where DVDD is powered up first. First it is assumed that DVDD is already up to specified operating voltage. When AVDD goes above the minimum threshold,  $V_{pora}$ , there is enough voltage for the circuit to guarantee PORB is asserted low and the chip is held in reset. In this condition, all writes to the control interface are ignored. When AVDD rises to  $V_{pora\_on}$ , PORB is released high and all registers are in their default state and writes to the control interface may take place.

On power down, where DVDD falls first, PORB is asserted low whenever DVDD drops below the minimum threshold  $V_{pord\_off}$ .

SYMBOL	MIN	TYP	MAX	UNIT
$V_{pora}$	0.4	0.6	0.8	V
$V_{pora\_on}$	0.9	1.2	1.6	V
$V_{pora\_off}$	0.4	0.6	0.8	V
$V_{pord\_on}$	0.5	0.7	0.9	V
$V_{pord\_off}$	0.4	0.6	0.8	V

**Table 1 Typical POR Operation (typical values, not tested)**

**Note:** It is recommended that every time power is cycled to the WM8224 a software reset is written to the software register to ensure that the contents of the control registers are at their default values before carrying out any other register writes.

## DEVICE DESCRIPTION

### INTRODUCTION

A block diagram of the device showing the signal path is presented on the front page of this datasheet.

The WM8224 samples up to three inputs (RINP, GINP and BINP) simultaneously. The device then processes the sampled video signal with respect to the video reset level or an internally/externally generated reference level using between one and three processing channels.

Each processing channel consists of an Input Sampling block with optional Reset Level Clamping (RLC) and Correlated Double Sampling (CDS), an 8-bit programmable offset DAC and a 9-bit Programmable Gain Amplifier (PGA).

The processing channel outputs are switched alternately by a 3:1 multiplexer to the ADC input.

The ADC then converts each resulting analogue signal to a digital word. The digital output from the ADC is presented in a variety of possible output formats onto the output bus, OP[11:0]. The twelve output pins can be set to a high impedance state using either the OEB control pin or the OPD register bit.

On-chip control registers determine the configuration of the device, including the offsets and gains applied to each channel. These registers are programmable via a serial interface.

The device has a Black-Level Calibration function which allows the D.C. offset determined during the optically-black pixels at the beginning of the linear sensor to be removed during the image-pixels.

### CONFIGURABLE RESOLUTION OF ADC

The WM8224 has a configurable ADC resolution. The default setting is 16 bits resolution. This can be changed by the user by changing a register setting.

The register RES[1:0] can be changed to alter the resolution from 16 bits to either 12, 10 or 8 bits resolution.

### INPUT SAMPLING

The WM8224 can sample and process up to three inputs through one to three processing channels as follows:

**Colour Pixel-by-Pixel:** The three inputs (RINP, GINP and BINP) are simultaneously sampled for each pixel and a separate channel processes each input. The signals are then multiplexed into the ADC, which converts all three inputs within the pixel period.

**Two Channel Pixel-by-pixel:** Two input channels (RINP and GINP, RINP and BINP, or GINP and BINP) are simultaneously sampled for each pixel and a separate channel processes each input. The signals are then multiplexed into the ADC, which converts both inputs within the pixel period. The unused channel can be changed via the control interface. The unused channel is powered down when this mode is selected.

**Monochrome:** A single chosen input (RINP, GINP, or BINP) is sampled, processed by the corresponding channel, and converted by the ADC. The choice of input channel can be changed via the control interface. The unused channels are powered down when this mode is selected.



In situations where the input video signal does not have a stable reference level it may be necessary to clamp only during those pixels which have a known state (e.g. the dummy, or "black" pixels at the start or end of a line on most image sensors). This is known as line-clamping and relies on the input capacitor to hold the DC level between clamp intervals. In non-CDS mode (CDS=0) this can be done directly by controlling the RSMP input pin to go high during the black pixels only. Note that internal input voltage buffers should be enabled using the FOL\_EN register bit when using this mode of operation.

Alternatively it is possible to use RSMP to identify the black pixels and enable the clamp at the same time as the input is being sampled (i.e. when VSMP is high and RSMP is high). This mode is enabled by setting CLMPCTRL=1 and the operation is shown in Figure 15.

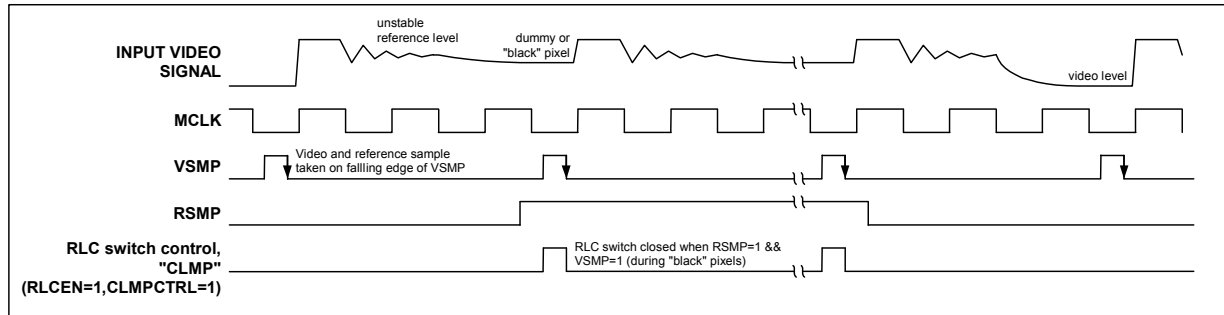

Figure 15 Reset Level Clamp Operation (CLMPCTRL=1), non-CDS mode only

RLCEN	CLAMPCTRL	OUTCOME	USE
0	X	RLC is not enabled. RLC switch is always open.	When input is DC coupled and within supply rails.
1	0	RLC switch is controlled directly from RSMP input pin: RSMP=0: switch is open RSMP=1: switch is closed	When ASIC explicitly provides a reset sample signal and the input video waveform has a suitable reset level.
1	1	VSMP applied as normal, RSMP is used to indicate the location of black pixels RLC switch is controlled by logical combination of RSMP and VSMP: RSMP && VSMP = 1: switch is closed Switch is re-opened when: VSMP=0 (non-CDS mode) VSMP=0 and RSMP=0 (CDS mode)	When clamping during the video period of black pixels or there is no stable per-pixel reference level. This method of operation is generally only sensible in non-CDS mode.

Table 2 Reset Level Clamp Control Summary

## CDS/NON-CDS PROCESSING

For CCD type input signals, containing a fixed reference/reset level, the signal may be processed using Correlated Double Sampling (CDS), which will remove pixel-by-pixel common mode noise. With CDS processing the input waveform is sampled at two different points in time for each pixel, once during the reference/reset level and once during the video level. To sample using CDS, register bit CDS must be set to 1 (default). This causes the signal reference to come from the video reference level as shown in Figure 16.

The video sample is always taken on the falling edge of the input VSMP signal (VS). In CDS-mode the reset level is sampled on the falling edge of the RSMP input signal (RS).

For input signals that do not contain a reference/reset level (e.g. CIS sensor signals), non-CDS processing is used (CDS=0). In this case, the video level is processed with respect to the voltage on pin VRLC/VBIAS. The VRLC/VBIAS voltage is sampled at the same time as VSMP samples the video level in this mode. Note that if the ac coupling capacitor ( $C_{IN}$ ) is used in non-CDS mode (CDS=0), then to minimise code drift, line clamping should be used and internal input voltage buffers enabled using the FOL\_EN register bit. Alternatively, if the input signal contains a stable reference/reset level then pixel clamping should be used, and the voltage buffers need not be enabled.

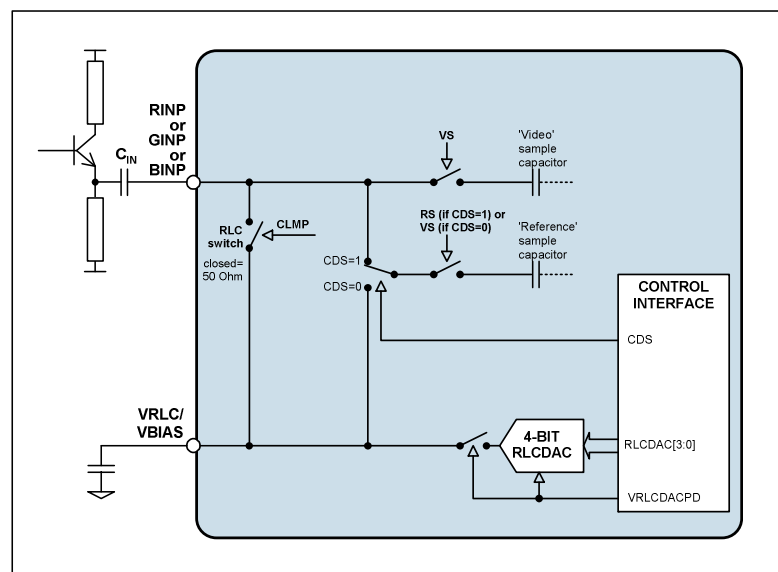

Figure 16 CDS/non-CDS Input Configuration

## OFFSET ADJUST AND PROGRAMMABLE GAIN

The output from the CDS block is a differential signal, which is added to the output of an 8-bit Offset DAC to compensate for offsets and then amplified by a 9-bit PGA. The gain and offset for each channel are independently programmable by writing to control bits DAC[7:0] and PGA[8:0].

The gain characteristic of the WM8224 PGA is shown in Figure 17. Figure 18 shows the maximum device input voltage that can be gained up to match the ADC full-scale input range (default=2V).

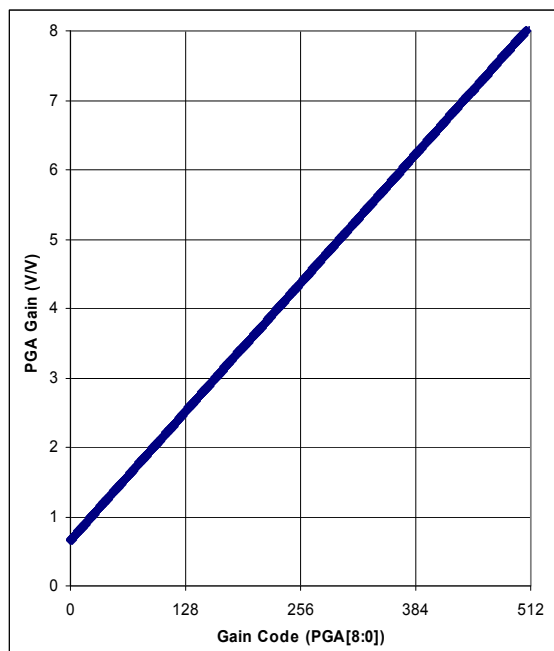

Figure 17 PGA Gain Characteristic

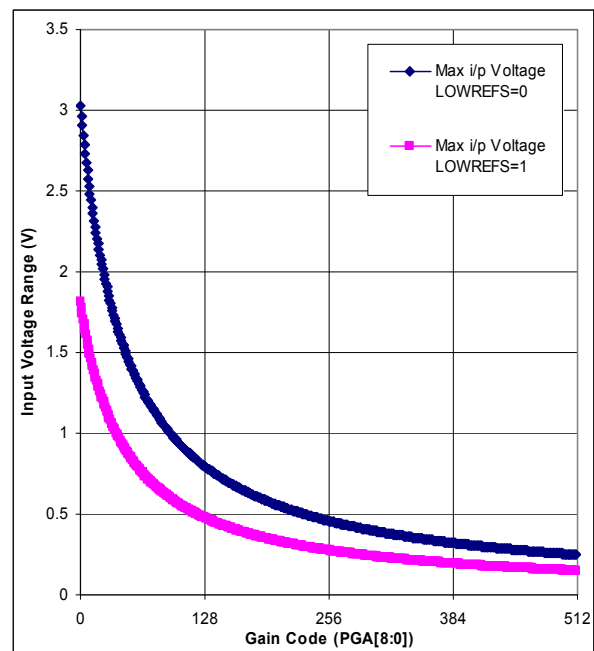

Figure 18 Peak Input Voltage to Match ADC Full-scale Range

## ADC INPUT BLACK LEVEL ADJUST

The output from the PGA can be offset to match the full-scale range of the differential ADC ( $2 \times [VRT-VRB]$ ).

For negative-going input video signals, a black level (zero differential) output from the PGA should be offset to the top of the ADC range by setting register bits PGAFS[1:0]=10. This will give an output code of FFFF (hex) from the WM8224 for zero input. If code zero is required for zero differential input then the INVOP bit should be set.

For positive going input signals the black level should be offset to the bottom of the ADC range by setting PGAFS[1:0]=11. This will give an output code of 0000 (hex) from the WM8224 for zero input.

Bipolar input video is accommodated by setting PGAFS[1:0]=00 or PGAFS[1:0]=01. Zero differential input voltage gives mid-range ADC output, 7FFF (hex).

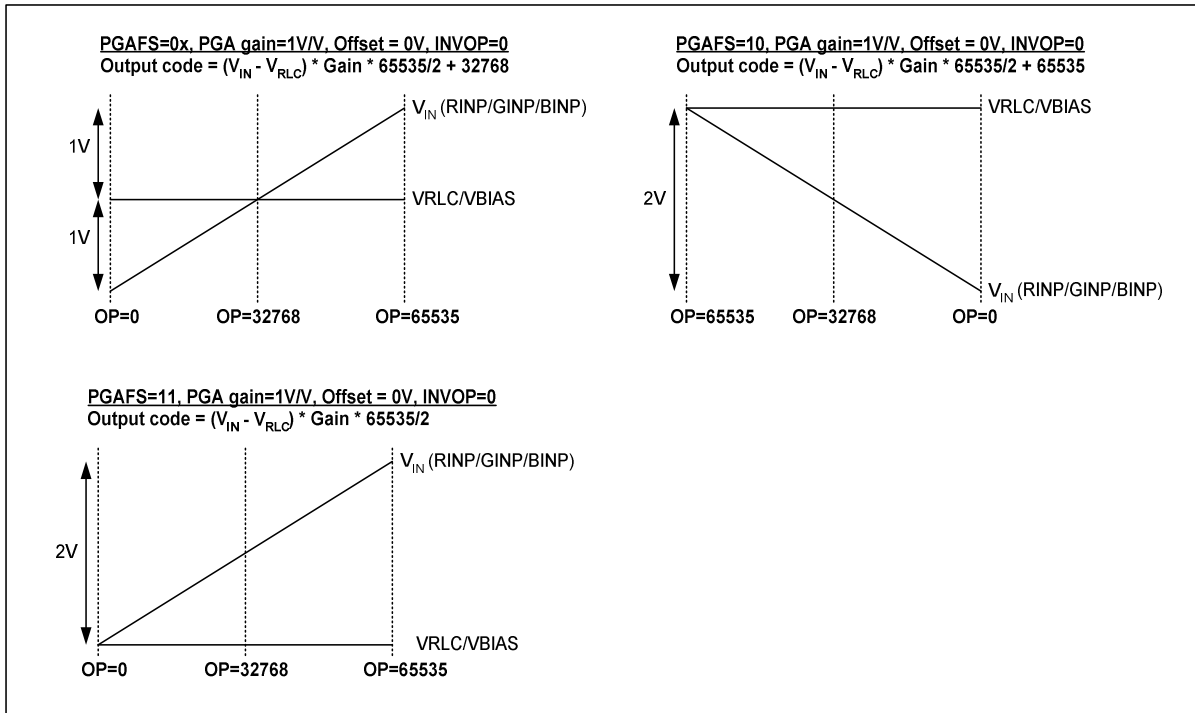

Figure 19 ADC Input Black Level Adjust Settings

**OVERALL SIGNAL FLOW SUMMARY**

Figure 20 represents the processing of the video signal through the WM8224.

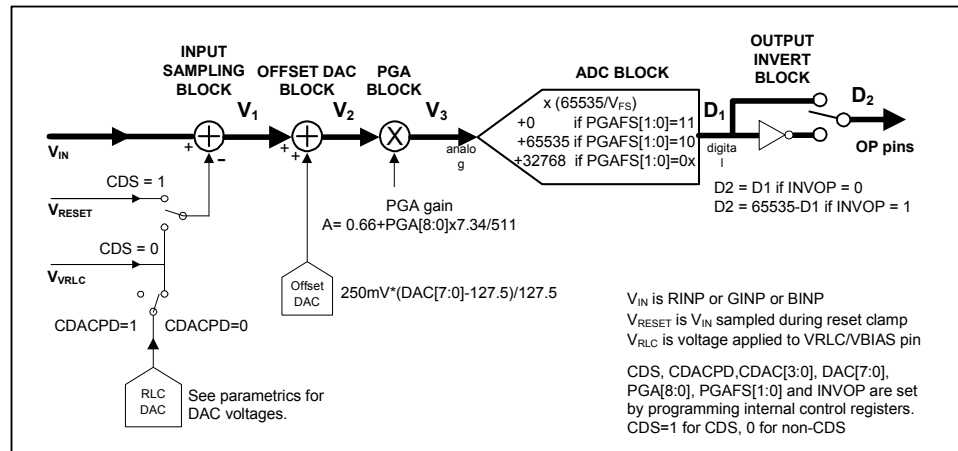

Figure 20 Overall Signal Flow

The **INPUT SAMPLING BLOCK** produces an effective input voltage  $V_1$ . For CDS, this is the difference between the input video level  $V_{IN}$  and the input reset level  $V_{RESET}$ . For non-CDS this is the difference between the input video level  $V_{IN}$  and the voltage on the VRLC/VBIAS pin,  $V_{RLC}$ , optionally set via the RLC DAC.

The **OFFSET DAC BLOCK** then adds the amount of fine offset adjustment required to move the black level of the input signal towards 0V, producing  $V_2$ .

The **PGA BLOCK** then amplifies the white level of the input signal to maximise the ADC range, outputting voltage  $V_3$ .

The **ADC BLOCK** then converts the analogue signal,  $V_3$ , to a 16-bit unsigned digital output,  $D_1$ .

The digital output is then inverted, if required, through the **OUTPUT INVERT BLOCK** to produce  $D_2$ .

## CALCULATING THE OUTPUT CODE FOR A GIVEN INPUT

The following equations describe the processing of the video and reset level signals through the WM8224.

### INPUT SAMPLING BLOCK: INPUT SAMPLING AND REFERENCING

If CDS = 1, (i.e. CDS operation) the previously sampled reset level,  $V_{\text{RESET}}$ , is subtracted from the input video,  $V_{\text{IN}}$  (= RINP, GINP or BINP).

$$V_1 = V_{\text{IN}} - V_{\text{RESET}} \quad \text{Eqn. 1}$$

If CDS = 0, (non-CDS operation) the simultaneously sampled voltage on pin VRLC is subtracted instead.

$$V_1 = V_{\text{IN}} - V_{\text{VRLC}} \quad \text{Eqn. 2}$$

If VRLCDACPD = 1,  $V_{\text{VRLC}}$  is an externally applied voltage on pin VRLC/VBIAS.

If VRLCDACPD = 0,  $V_{\text{VRLC}}$  is the output from the internal RLC DAC.

$$V_{\text{VRLC}} = (V_{\text{RLCSTEP}} * \text{RLC DAC}[3:0]) + V_{\text{RLCBOT}} \quad \text{Eqn. 3}$$

$V_{\text{RLCSTEP}}$  is the step size of the RLC DAC and  $V_{\text{RLCBOT}}$  is the minimum output of the RLC DAC.

### OFFSET DAC BLOCK: OFFSET (BLACK-LEVEL) ADJUST

The resultant signal  $V_1$  is added to the Offset DAC output.

$$V_2 = V_1 + \{250\text{mV} * (\text{DAC}[7:0] - 127.5)\} / 127.5 \quad \text{Eqn. 4}$$

### PGA NODE: GAIN ADJUST

The signal is then multiplied by the PGA gain.

$$V_3 = V_2 * (0.66 + \text{PGA}[8:0] * 7.34 / 511) \quad \text{Eqn. 5}$$

### ADC BLOCK : ANALOGUE-DIGITAL CONVERSION

The analogue signal is then converted to a 16-bit unsigned number, with input range configured by PGAFS[1:0].

$$D_1[15:0] = \text{INT}\{ (V_3 / V_{\text{FS}}) * 65535\} + 32767 \quad \text{PGAFS}[1:0] = 00 \text{ or } 01 \quad \text{Eqn. 6}$$

$$D_1[15:0] = \text{INT}\{ (V_3 / V_{\text{FS}}) * 65535\} \quad \text{PGAFS}[1:0] = 11 \quad \text{Eqn. 7}$$

$$D_1[15:0] = \text{INT}\{ (V_3 / V_{\text{FS}}) * 65535\} + 65535 \quad \text{PGAFS}[1:0] = 10 \quad \text{Eqn. 8}$$

where the ADC full-scale range,  $V_{\text{FS}} = 2\text{V}$  when LOWREFS=0 and  $V_{\text{FS}} = 1.2\text{V}$  when LOWREFS=1.

### OUTPUT INVERT BLOCK: POLARITY ADJUST

The polarity of the digital output may be inverted by control bit INVOP.

$$D_2[15:0] = D_1[15:0] \quad (\text{INVOP} = 0) \quad \text{Eqn. 9}$$

$$D_2[15:0] = 65535 - D_1[15:0] \quad (\text{INVOP} = 1) \quad \text{Eqn. 10}$$



## OUTPUT FORMATS

The output from the WM8224 can be presented in several different formats under control of the OPFORM register bit as shown in Figure 21. In addition the data can be presented at different resolutions.

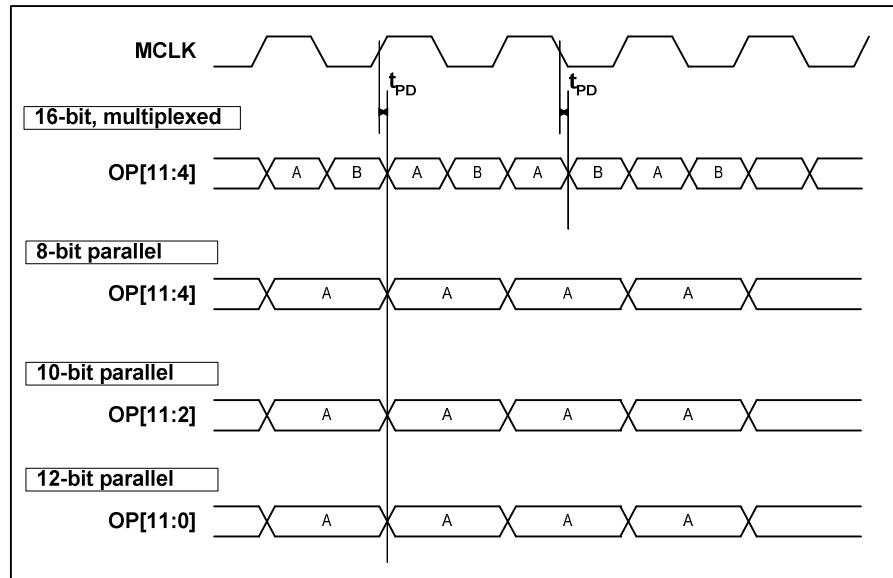

Figure 21 Output Data Formats

OPFORM	OUTPUT FORMAT	OUTPUT PINS	RES[1:0]	RESOLUTION	OUTPUT
0	Multiplexed	OP[11:4]	11	16-bit	A[7:0] = {d15, d14, d13, d12, d11, d10, d9, d8} B[7:0] = {d7, d6, d5, d4, d3, d2, d1, d0}
			10	12-bit	A[7:0] = {d15, d14, d13, d12, d11, d10, d9, d8} B[7:0] = {d7, d6, d5, d4, 0, 0, 0, 0}
			01	10-bit	A[7:0] = {d15, d14, d13, d12, d11, d10, d9, d8} B[7:0] = {d7, d6, 0, 0, 0, 0, 0, 0}
			00	8-bit	Not valid
1	Parallel	OP[11:0]	11	16-bit	Not valid
		OP[11:0]	10	12-bit	A[11:0] = {d15, d14, d13, d12, d11, d10, d9, d8, d7, d6, d5, d4}
		OP[11:2]	01	10-bit	A[9:0] = {d15, d14, d13, d12, d11, d10, d9, d8, d7, d6}
		OP[11:4]	00	8-bit	A[7:0] = {d15, d14, d13, d12, d11, d10, d9, d8}

Table 3 Details of Output Data Formats (as shown in Figure 21)

## PROGRAMMABLE AUTOMATIC BLACK LEVEL CALIBRATION

The Programmable Automatic Black-Level Calibration (BLC) function is to adjust the D.C. offset of the output data such that the digital output code for black pixels is calibrated to a target black level value. The D.C. offset is determined during the optically-black pixels at the beginning of the linear sensor, and removed during the image-pixels as shown in Figure 22.

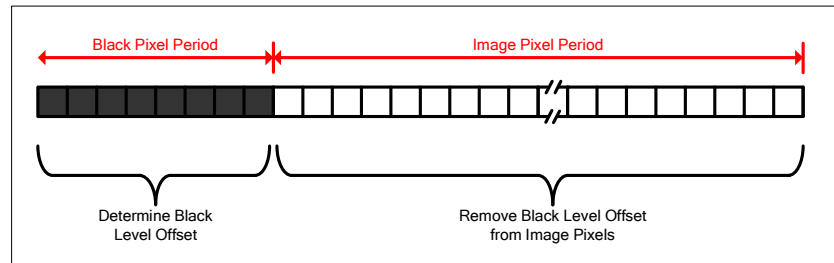

Figure 22 Linear Sensor Model

The automatic black level calibration operates assuming 12 bits ADC resolution. Adjustments to calculations must be made for different ADC resolutions.

The black level calibration process occurs in two stages as shown in Figure 23 below:

- **Coarse Adjust Calibration:** This is a mixed signal loop which removes the coarse offset by adjusting the offset DAC.
- **Fine Adjust Calibration:** This is a digital loop which removes the remaining offset with better noise tolerance, utilising ADC over-range to improve the dynamic range of the system.

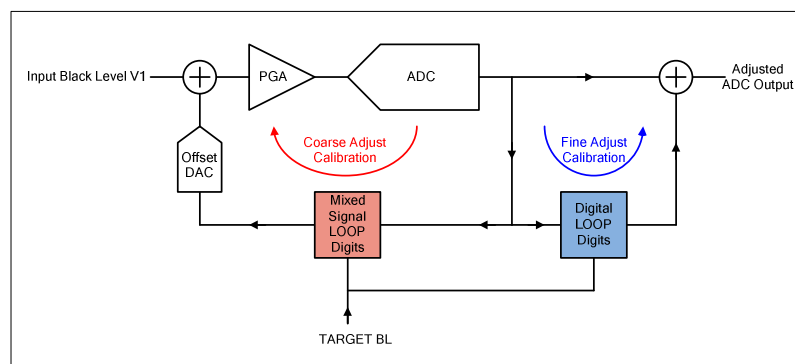

Figure 23 BLC Top-Level Circuitry

### TARGET CODES

The user must specify a target black level for each Red, Green and Blue channel through the registers TARGETR, TARGETG and TARGETB. If, during the black-pixel period, the average ADC output code was, for example, 100 and the user specified the target black level code to be 10, the BLC circuitry would determine 90 codes should be subtracted from the ADC output. These 90 codes will then be subtracted from every image-pixel code output from the ADC.

Note – changing the PGA gain affects the black-level through the device; the gain should therefore not be changed during a BLC procedure. If the PGA gain changes, then the BLC routine should be re-run.

The automatic black level calibration feature operates with the assumption of a 12bit ADC resolution. The register settings for Target Codes (TARGETx[7:0]) should be set differently depending on the ADC resolution being used. As TARGETx[7:0] is an 8 bit register, the 4 MSBs of a data output code cannot be changed.

**16bit ADC Resolution**

For 16bit resolution the target code entered into TARGETx[7:0] will ignore the 4 MSBs and 4 LSBs of the 16-bit data output. For example if the desired code out is 0000111111110001, the value entered into TARGETx[7:0] would be 11111111.

**12bit ADC Resolution**

For 12bit resolution the 4 MSBs of the 12 bit data output code will be ignored. For example if the desired code out is 000011111111, the value entered into TARGETx[7:0] would be 11111111.

**10bit ADC Resolution**

For 10bit resolution the 4 MSBs of the 10bit data output code will be ignored. The 2 LSBs of the target code should be set to '00'. For example if the desired code out is 0000111111, the value entered into TARGETx[7:0] would be 11111100.

**8bit ADC Resolution**

For 8bit resolution the 4 MSBs of the 8bit data output code will be ignored. The 4 LSBs of the target code should be set to '0000'. For example if the desired code out is 00001111, the value entered into TARGETx[7:0] would be 11110000.

**INDICATING THE START OF A BLC PROCEDURE**

The start of a line is required to be indicated to the WM8224 to allow the black-pixel period to be located. This can be achieved by two methods. The register TG\_METHOD is set to reflect which method is to be used.

**METHOD 1: OEB PIN**

The OEB pin can be shared with the BLC function to indicate the start of a line if the OEB functionality is not required. To indicate the start of a line, send a line synchronisation pulse, TG, on the OEB pin. It must be high for at least one rising edge of MCLK. The TG\_METHOD register must be set to either '10' or '11' depending on whether positive or negative edge triggering is required, as shown in Figure 24.

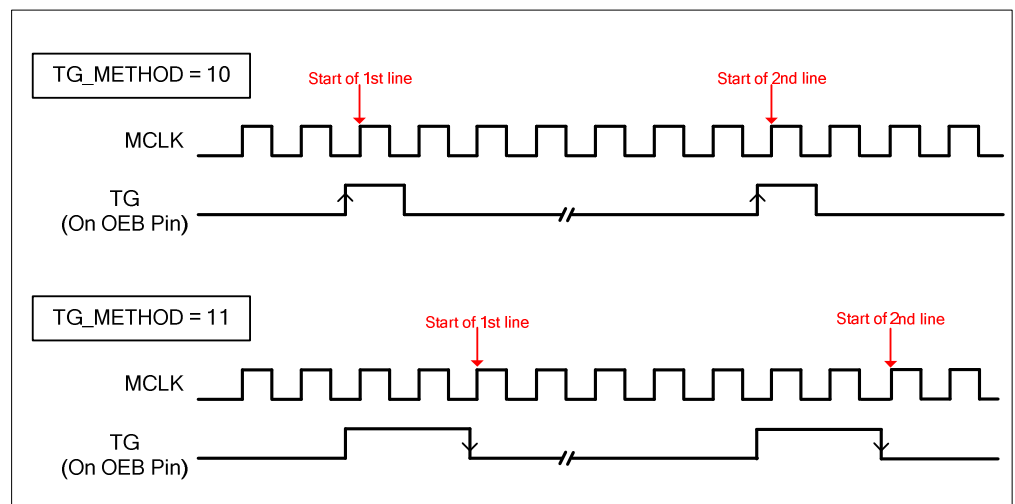

**Figure 24 Start of Line Indicator Using TG on the OEB Pin**

**METHOD 2: REGISTER WRITE**

The start of a line can also be indicated using a register write to TG\_REG. The first rising edge of MCLK after TG\_REG goes high will indicate the start of the line. TG\_REG shall be automatically set to zero by the device. This process can be repeated to indicate the start of a second line, as shown in Figure 25. Set TG\_METHOD to '00'

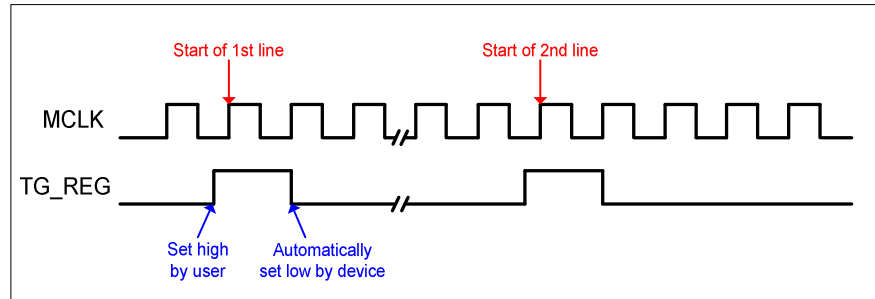

**Figure 25 Start of Line Indicator Using TG\_REG**

**BLC DURATION CONTROL**

**DUMMY PIXEL DELAY**

Once the start of line has been determined there can be a delay to allow for the dummy pixels at the start of the sensor to be ignored. This is controlled by BLC\_DEL, which is the number of pixels there should be between the start of line indicator and the start of the BLC routine.

The register BPIX\_AVAIL must also be set up for the number of black pixels available to carry out the calibration. The durations of the Coarse Adjust Calibration and Fine Adjust calibration can then be determined as detailed below.

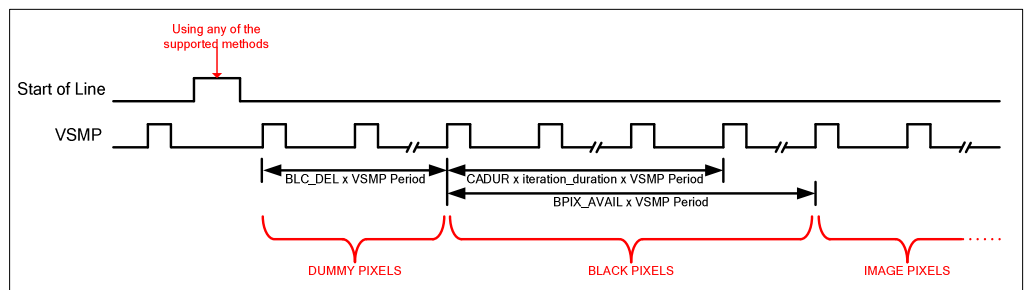

**Figure 26 BLC Duration Control**

**COARSE ADJUST CALIBRATION ITERATION DURATION**

The duration of one iteration of the Coarse Adjust is an integer number of VSMP periods. The exact number of VSMP periods depends on the MCLK:VSMP ratio and the number of channels used. The implementation ensures that there are at least a certain number of MCLK's per Coarse Adjust iteration as shown in Table 4.

MODE	MINIMUM NO. OF MCLKS PER COARSE ADJUST ITERATION
3-Channel	11
2-Channel	10
Mono	9

**Table 4 Modes vs MCLKs for Coarse Iterations**

The BLC design rounds the Coarse Adjust iteration duration up to a whole number of pixels (i.e. the iteration duration will be a whole number of VSMP periods).

### FINE ADJUST CALIBRATION DURATION

The Fine Adjust calibration duration is determined by the number of remaining black pixels after the coarse adjust has taken place.

### BLC TEST MODE

This mode allows the status of the BLC to be seen on the 2 LSBs of the output data pins OP[1:0]. This mode could be enabled during the setup stage of the device to ensure that the black level calibration does not encroach on the active pixel data. Set the STATEOUT register to enable this mode. Once the BLC register values have been determined this register should be disabled. Table 5 shows the description of the output data.

DATA ON OP[1:0]	DESCRIPTION
00	No BLC
01	Dummy Pixels
10	Coarse Adjust Calibration
11	Fine Adjust Calibration

**Table 5 Test Mode Outputs**

### BLC WORKED EXAMPLE:

Below is an example of how to configure the WM8224 for Black Level Calibration.

#### Assumptions

MCLK frequency	= 40MHz
VSMP frequency	= 13.33MHz
Mode of operation	= 3 Channel Mode
Black pixels on sensor	= 50
Dummy pixels on sensor	= 20

The following stages set up the Black Level calibration although not all stages may be required depending on the application:

1. Set up the Dummy Pixel Delay
2. Define the Coarse Adjust Calibration
3. Define the Fine Adjust Calibration

### 1. **Dummy Pixel delay**

Set BLC\_DEL, the number of dummy pixels for the sensor

BLC\_DEL = '0010100'

The duration for this will then be BLC\_DEL \* VSMP period

Dummy pixel delay = 20\*75ns = 1.5us

### 2. **Define the coarse adjust loop**

When setting the coarse adjust calibration it is necessary to bear in mind the following:

- The number of black pixels available
- The coarse adjust iteration duration
- The number of iterations required.

Step 1: Set up BPIX\_AVAIL with the number of available black pixels for the sensor.

BPIX\_AVAIL = '0000110010'

Step 2: Calculate MCLK:VSMP ratio

40:13.33 = 3:1

Step 3: Calculate the duration of the iteration in no. of pixels (round up value). Refer to Table 4 for the number of MCLK's per Coarse Adjust iteration

$$\frac{\text{no. of MCLKs}}{(\text{MCLK : VSMP})\text{ratio}} = \text{no. of pixels}$$

$$\frac{\text{no. of MCLKs}}{(\text{MCLK : VSMP})\text{ratio}} = \frac{11}{3} = 3.67$$

Round up this value to give the no of pixels per iteration

= 4 pixels per iteration

Note: The device will automatically calculate this value.

Step 4: Set the register CADUR for max number of iterations.

CADUR = 2

Theoretically there can be 7 coarse adjust iterations during the black pixel period. However, in most cases 2 would be sufficient depending on the number of black pixels available to allow time for the fine adjust loop.

### 3. **Fine Adjust Calibration**

Step 1: Enable Register FA\_EN to allow for fine adjust calibration

Step 2: The time available for fine adjustment is determined by the no. of remaining black pixels after the coarse adjust has taken place.

BPIX\_AVAIL – (CADUR\* iteration duration)

50 – (2\*4)

= 42 pixels

## BLC SCENARIOS OF OPERATION

The BLC can be used in various ways to suit the application, for example calibration can be done once per page or once per line. Register set up should be carried out before the start of a frame and is not required to be done on a line by line basis if using the Method 1 OEB PIN method. Five potential scenarios of operation are suggested below.

Note: The registers FRAME\_START and SEQ\_START when set high by the user will automatically be set low by the device.

### SCENARIO 1

Coarse Adjust Calibration enabled for the 1<sup>st</sup> line, Fine Adjust Calibration enabled every line with the Fine Adjust Calibration result recalculated every line. This scenario is suitable for dealing with large amounts of d.c. drift throughout a frame; but this is at a cost of potential line-by-line variation in the Fine Adjust result (dependent on sensor noise and the PGA gain). Table 6 shows which registers are required for this scenario with example settings.

SETUP REGISTER	BPIX_AVAIL	CADUR	FRAME_START	FA_EVERYLINE
Value	50	2	1	1

Table 6 Example Register Settings for Scenario 1

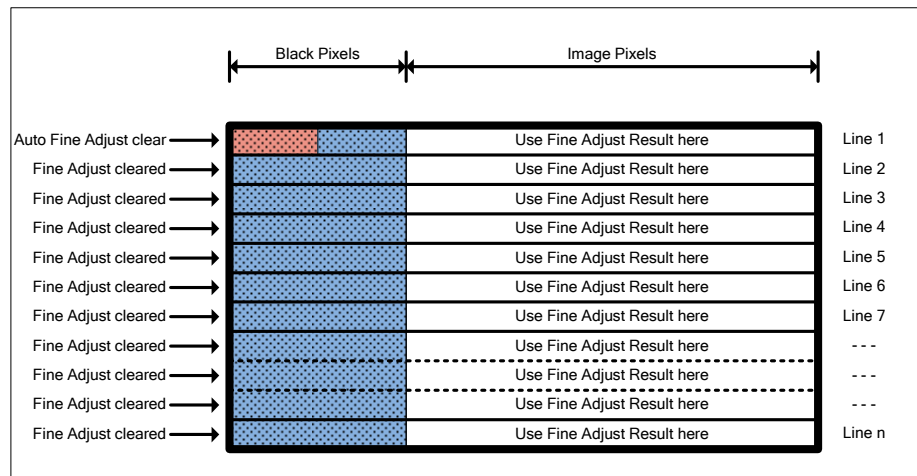

Figure 27 Scenario 1

**SCENARIO 2**

Coarse Adjust and Fine Adjust Calibration enabled for the 1<sup>st</sup> line, with the Fine Adjust result updated on the 1<sup>st</sup> line only. This scenario is suitable for adjusting for black-level d.c. drift on a frame-by-frame basis; there will be no line-by-line variation in the black-level from the BLC circuitry. Table 7 shows which registers are required for this scenario with example settings.

SETUP REGISTER	BPIX_AVAIL	CADUR	FRAME_START
Value	50	2	1

Table 7 Example Register Settings for Scenario 2

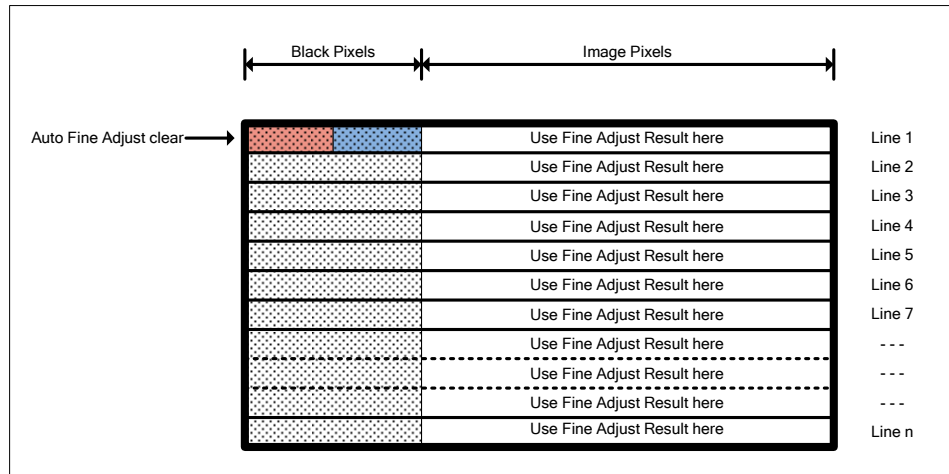

Figure 28 Scenario 2

**SCENARIO 3**

Coarse Adjust Calibration enabled for the 1<sup>st</sup> line, Fine Adjust Calibration enabled every line with the Fine Adjust result accumulated throughout frame and used every line. This scenario allows any variation in the black-level to be tracked throughout the frame by accumulating the Fine Adjust result over multiple lines. This method does not deal with as large amounts of d.c. drift throughout the frame as scenario 1, but it will produce less line-by-line variation. Table 8 shows which registers are required for this scenario with example settings.

SETUP REGISTER	BPIX_AVAIL	CADUR	FRAME_START	FA_EVERYLINE	FA_ACCUM
Value	50	2	1	1	1

Table 8 Example Register Settings for Scenario 3

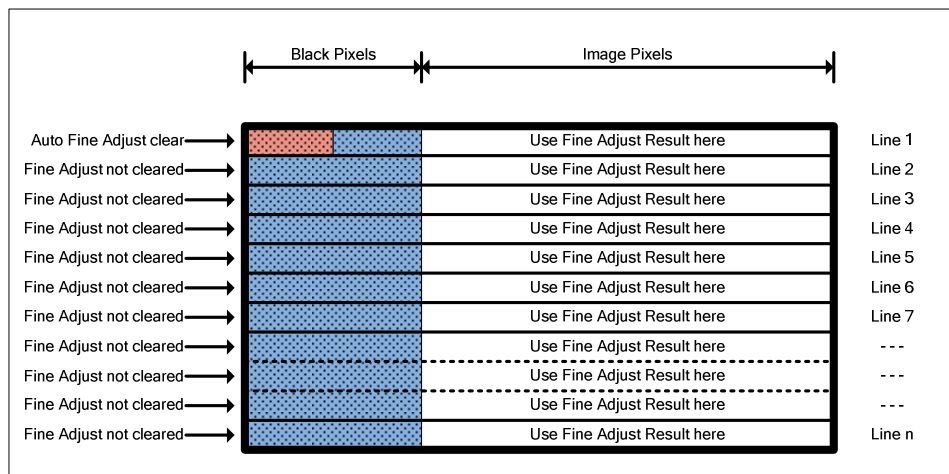

Figure 29 Scenario 3



**SCENARIO 4**

Coarse Adjust Calibration enabled for 1<sup>st</sup> line, Fine Adjust Calibration enabled every line with the Fine Adjust result accumulated throughout frame and used at start of next frame. This scenario is intended to be used with a sequence of multiple frames, the first frame being used as a calibration frame. This is good for use with sensors containing very few black-pixels as the black-level offset can be calculated over an entire frame and there will be no line-by-line variation in the black-level from the BLC circuitry. Table 9 shows which registers are required for this scenario with example settings.

SETUP REGISTER	BPIX_AVAIL	CADUR	FRAME_START	FRAME_SEQ	SEQ_START	FA_EVERYLINE	FA_ACCUM
Value	50	2	1	1	1	1	1

Table 9 Example Register Settings for Scenario 4

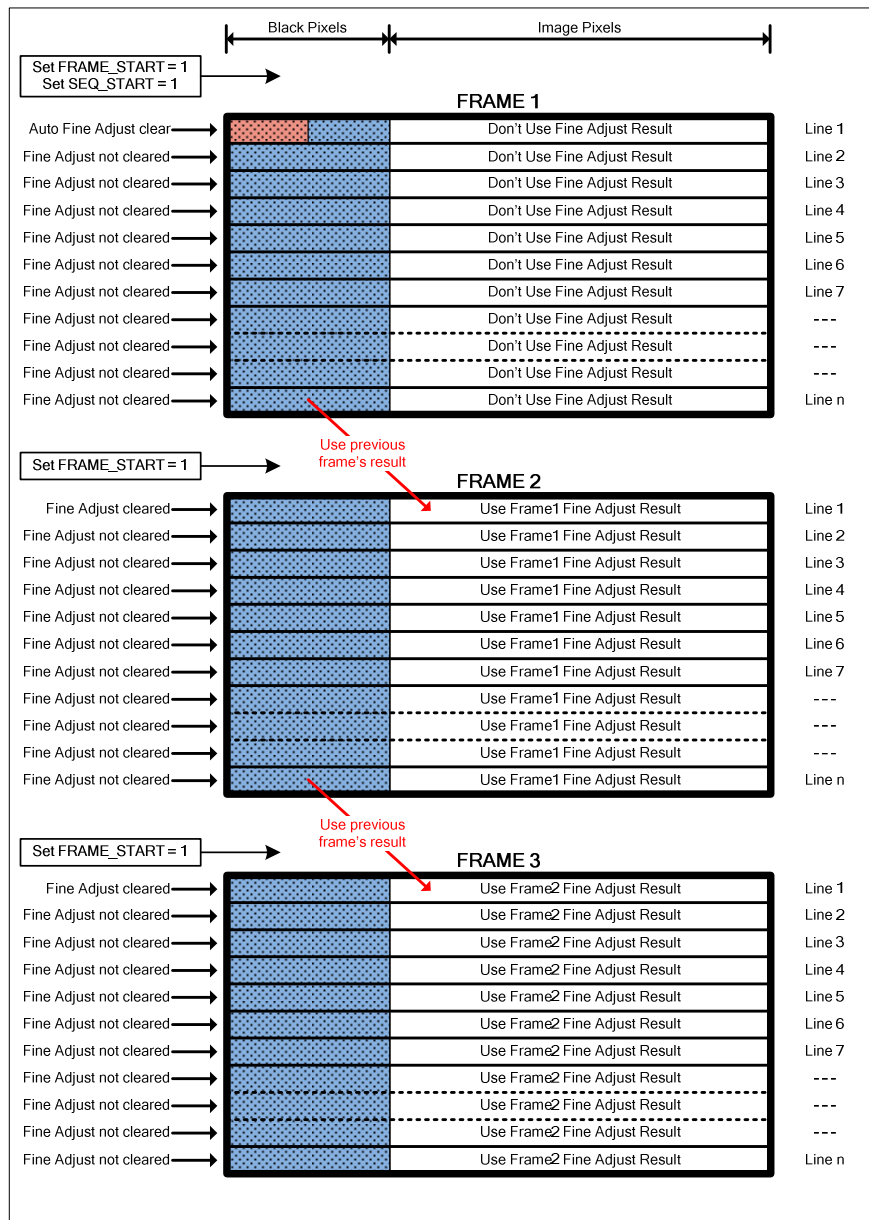

Figure 30 Scenario 4

**SCENARIO 5**

This scenario utilises the information from a possible calibration black-strip at the start of a scan. The register LINE\_DEL sets the number of lines from the start of the frame that the BLC procedure is to be performed, so as to coincide with the calibration strip. Table 10 shows which registers are required for this scenario with example settings.

SETUP REGISTER	BPIX_AVAIL	CADUR	LINE_DEL	FRAME_START	FA_EVERYLINE
Value	1000	2	50	1	1

Table 10 Example Register Settings for Scenario 5

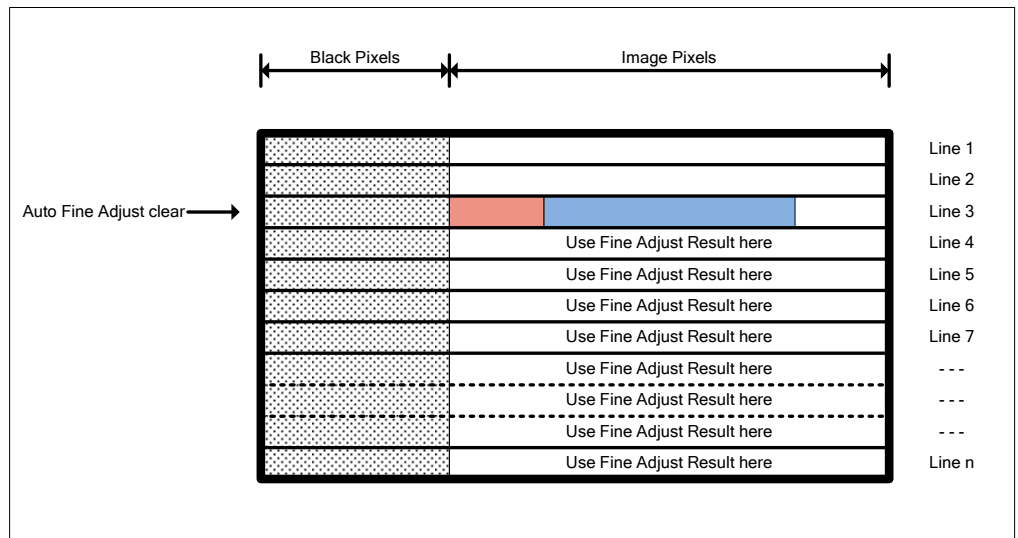

Figure 31 Scenario 5

## REFERENCES

The ADC reference voltages are derived from an internal bandgap reference, and buffered to pins VRT and VRB, where they must be decoupled to ground. Pin VRX is driven by a similar buffer, and also requires decoupling. The output buffer from the RLCDAC also requires decoupling at pin VRLC/VBIAS.

The ADC references can be switched from the default values (VRT=2.05V, VRB=1.05V, ADC input range=2V) to give a smaller ADC reference range (VRT=1.85V, VRB=1.25V, ADC input range=1.2V) under control of the LOWREFS register bit. Setting LOWREFS=1 allows smaller input signals to be accommodated.

**Note:**

When LOWREFS = 1 the output of the RLCDAC will scale if RLCDACRNG = 1. The max output from RLCDAC will change from 2.05 to 1.85V and the step size will proportionally reduce.

## POWER MANAGEMENT

Power management for the device is performed via the Control Interface. By default the device is fully enabled. The EN bit allows the device to be fully powered down when set low. Individual blocks can be powered down using the bits in Setup Register 5. When in MONO or TWOCHAN mode the unused input channels are automatically disabled to reduce power consumption.

Note: It is recommended that if the clocks are removed from the device, the device should be powered down using the EN bit in Setup Reg 1.

## CONTROL INTERFACE

The internal control registers are programmable via the serial digital control interface. The register contents can be read back via the serial interface on pin OP[11]/SDO.

It is recommended that a software reset is carried out after the power-up sequence, before writing to any other register. This ensures that all registers are set to their default values (as shown in Table 15).

### DEVICE IDENTIFICATION

Up to 3 WM8224 devices can share a common set of serial interface pins. Each device on the common interface bus must be given a different device ID. The device ID is set by the input pin DSLCT as shown in Table 11 Device Identification.

DSLCT	DEVICE ID (ID[1:0])
0	00
1	01
Z	10

**Table 11 Device Identification**

### REGISTER WRITE

Figure 32 shows sequence of operations for performing a register write. Three pins, SCK, SDI and SEN are used for the control interface. An eight-bit address (id1, id0, a5, 0, a3, a2, a1, a0) is clocked in through SDI, MSB first, followed by an eight-bit data word (b7, b6, b5, b4, b3, b2, b1, b0), also MSB first. The device ID bits indicate which device is being written to on a shared control bus. A register write with device ID set to 11 writes data to all devices on the common bus. Setting address bit a4 to 0 indicates that the operation is a register write. Each bit is latched on the rising edge of SCK. When the data has been shifted into the device, a rising edge on the SEN pin transfers the data to the appropriate internal register.

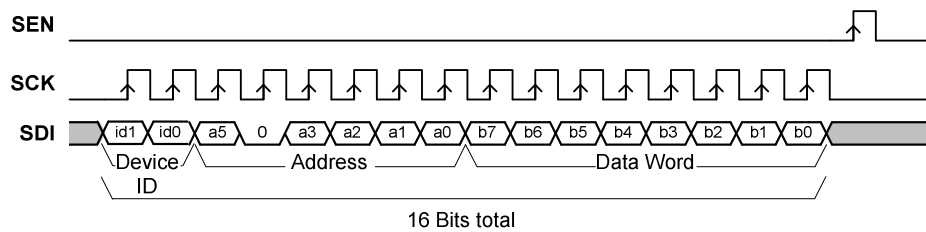
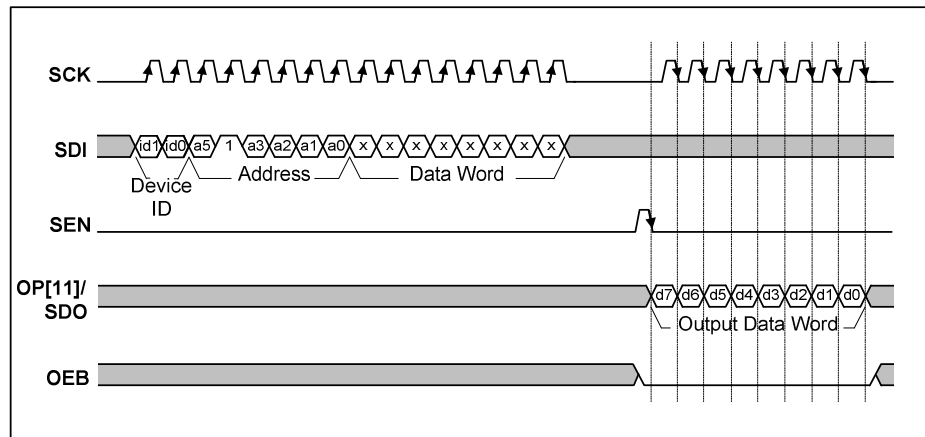

**Figure 32 Control Interface Register Write**

A software reset is carried out by writing to Address "000100" with any value of data, (i.e. Data Word = XXXXXXXX).

**REGISTER READ-BACK**

Figure 33 shows register read-back in serial mode. Read-back is initiated by writing to the serial bus as described above but with address bit a4 set to 1, followed by an 8-bit dummy data word. Writing address (id1, id0, a5, 1, a3, a2, a1, a0) will cause the contents (d7, d6, d5, d4, d3, d2, d1, d0) of corresponding register in the addressed device to be output MSB first on pin SDO (on the falling edge of SCK). Note that pin SDO is shared with an output pin, OP[11], and readback will override a high-impedance output on this pin. The next word may be read in to SDI while the previous word is still being output on SDO.



**Figure 33 Serial Interface Register Read-back**

**MULTIPLE DEVICE OPERATION**

Up to 3 WM8224 devices can be configured to share common serial interfaces and output data buses. In order to accommodate multiple devices on a shared output bus a higher number of MCLKs per VSMP are required.

When multiple devices are being used the WM8224 can be configured so that the outputs are high impedance apart from during valid data output by setting the AUTOZ register bit to 1. [Note that AUTOZ should not be used if the MCLK : VSMP ratio is 1:1.] The output of each device can be staggered by adjusting the latency via the OPDEL[3:0] register bits, allowing multiple devices to share the same output bus.

**BUS CONTENTION**

In 3 channel mode, an MCLK:VSMP ratio of 8:1 (2 devices) or 12:1 (3 devices) is recommended to give an spare MCLK cycle in which to allow the output data pins to transition in and out of a high impedance state. However an MCLK:VSMP ratio of 6:1 (2 devices) or 9:1 (3 devices) can be used, but care must be taken with output timing to prevent bus contention.

**EXAMPLE : TWO DEVICE, 6-CHANNEL, MCLK:VSMP=8:1, OPERATION**

Figure 34 shows how two devices can be configured to share a single data bus and a single control interface bus thus reducing pin count on the receiving ASIC.

The timing for this mode is shown in Figure 35.

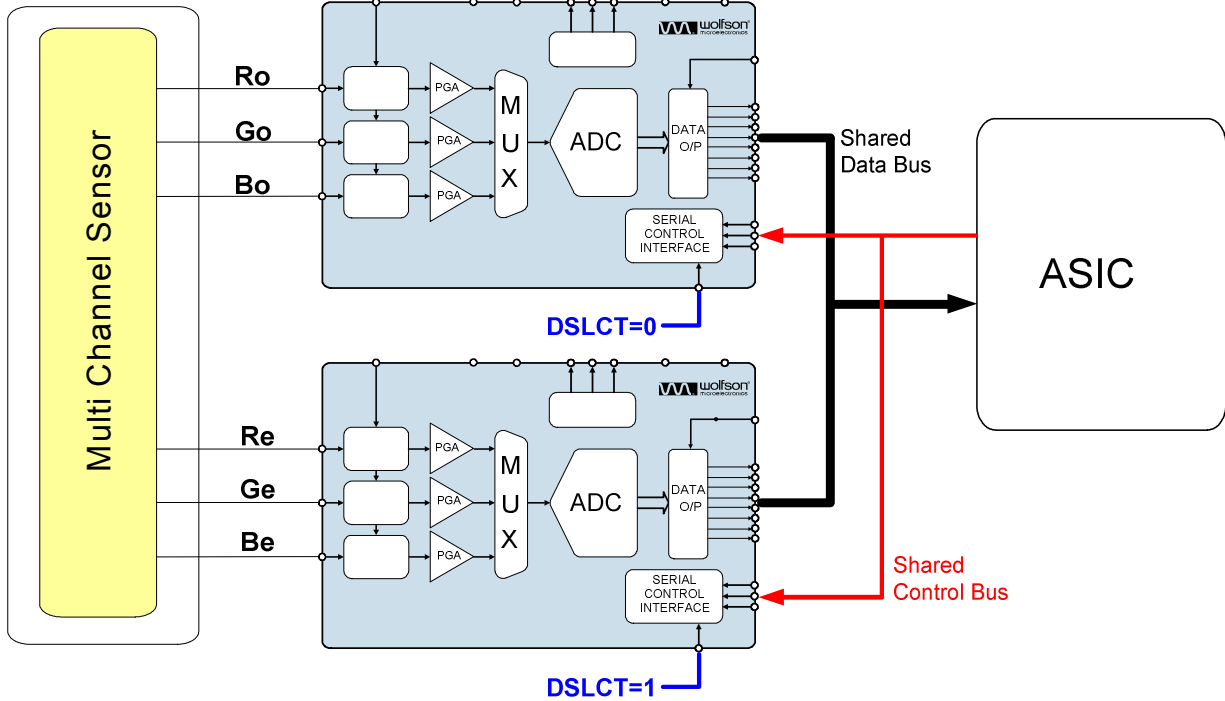

**Figure 34 Two device, 6-channel, MCLK:VSMP=8:1, Schematic**

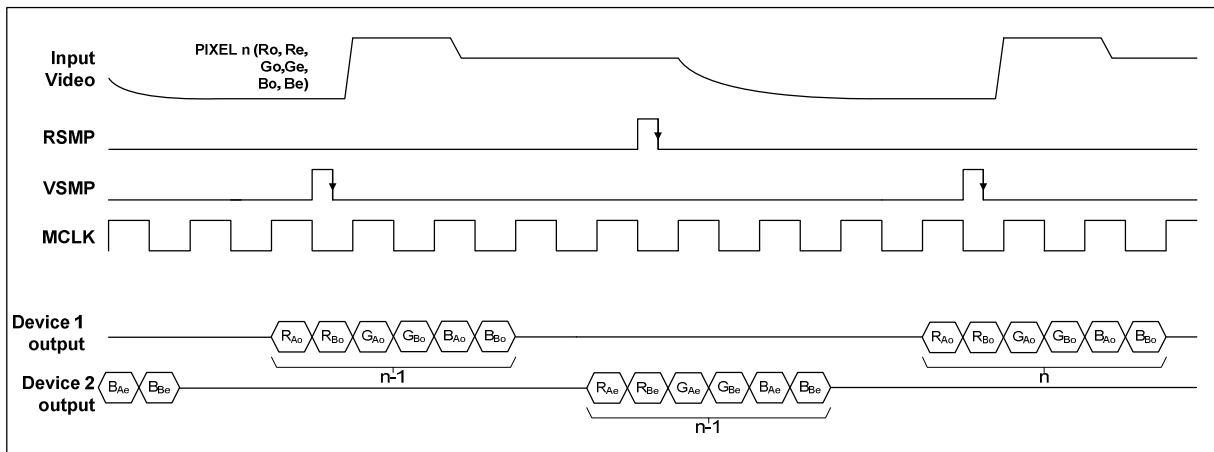

**Figure 35 Two device, 6-channel, MCLK:VSMP=8:1, Timing Diagram**

**OPERATING MULTIPLE DEVICES AT UP TO 60MHZ IN UP TO 16 BIT MODE**

If using multiple devices, then up to 16bit operation can be obtained with an MCLK frequency of up to 60MHz, by dividing down the internal MCLK, using ACLKDIV.

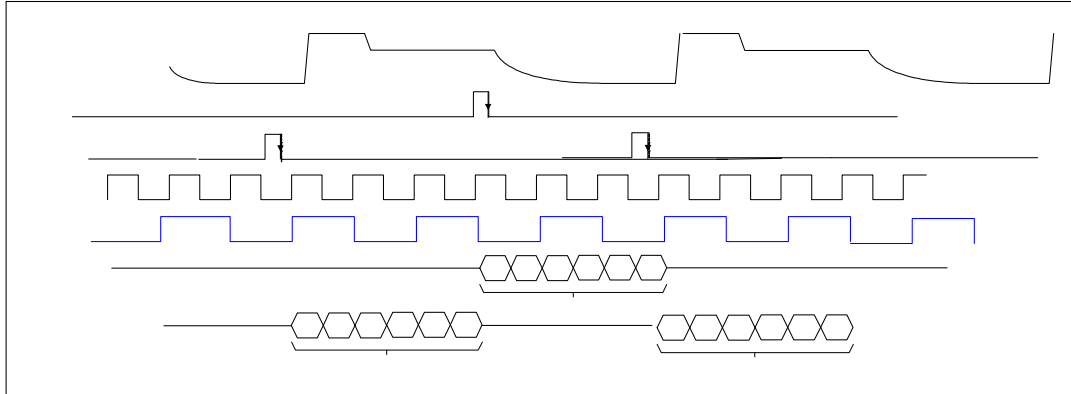

Figure 36 – Timing with aclk=mclk/2 (ACLKDIV=01)

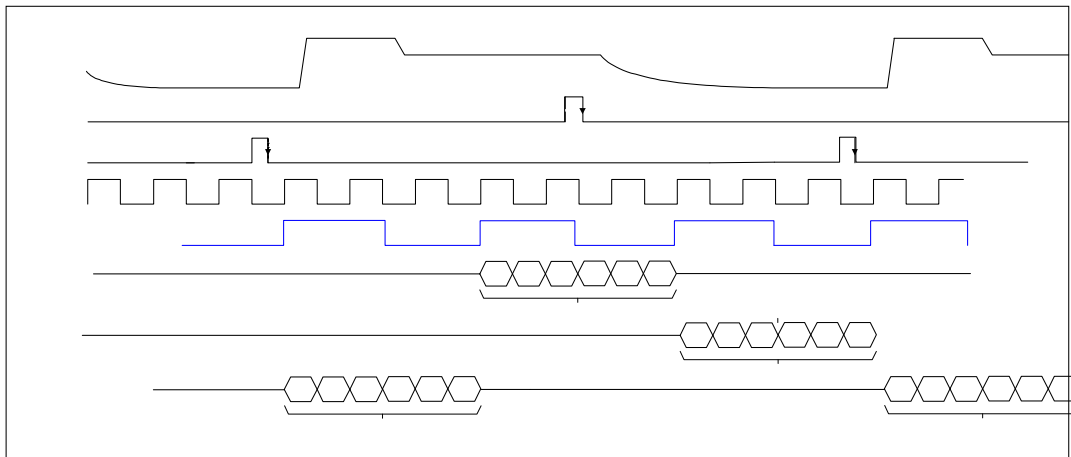

Figure 37 – Timing with aclk=mclk/3 (ACLKDIV=10)

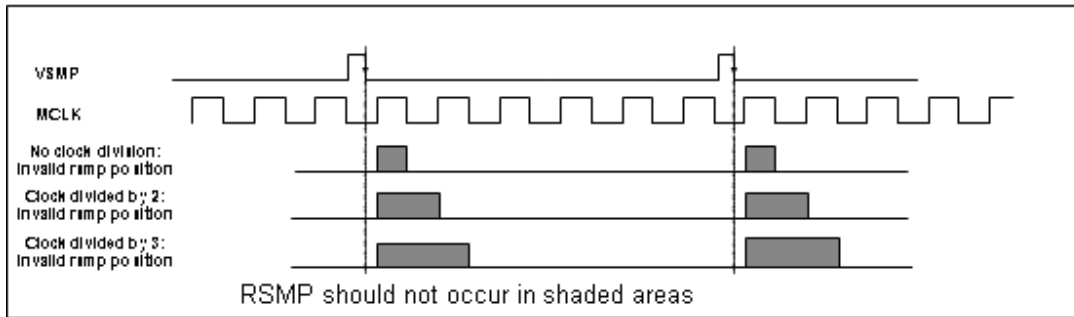

Figure 38 – Invalid rsmp positions

## OPERATING MODES

Table 12 and Table 13 below show the normal operating modes of the device. The MCLK speed can be changed along with the MCLK:VSMP ratio to achieve the desired sample rate.

### 16 BIT MODE

NUMBER OF CHANNELS	DESCRIPTION	CDS AVAILABLE	MAXIMUM SAMPLE RATE	TIMING REQUIREMENTS	REGISTER SETTINGS	
9	3 Devices Used	YES	4.4 MSPS	MCLK max = 40MHz Minimum MCLK:VSMP ratio = 9:1	MONO = 0 TWOCHAN = 0 AUTOZ=1 ACLKDIV = 00	
					Dev ID	OPDEL[3:0]
					00	0000
					01	0100
6	2 Devices Used	YES	6.6 MSPS	MCLK max = 40MHz Minimum MCLK:VSMP ratio = 6:1	MONO = 0 TWOCHAN = 0 AUTOZ=1 ACLKDIV = 00	
					Dev ID	OPDEL[3:0]
					00	0000
					01	0100
9	3 Devices Used	YES	6.6 MSPS	MCLK max = 60MHz Minimum MCLK:VSMP ratio = 9:1	MONO = 0 TWOCHAN = 0 AUTOZ=1 ACLKDIV = 10	
					Dev ID	OPDEL[3:0]
					00	0000
					01	0100
6	2 Devices Used	YES	10 MSPS	MCLK max = 60MHz Minimum MCLK:VSMP ratio = 6:1	MONO = 0 TWOCHAN = 0 AUTOZ=1 ACLKDIV = 01	
					Dev ID	OPDEL[3:0]
					00	0000
					01	0100
3	Three channel Pixel-by-Pixel	YES	13.33 MSPS	MCLK max = 40MHz Minimum MCLK:VSMP ratio = 3:1	MONO = 0 TWOCHAN = 0	
2	Two channel Pixel-by-Pixel	YES	20 MSPS	MCLK max = 40MHz Minimum MCLK:VSMP ratio = 2:1	MONO = 0 TWOCHAN = 1	
1	One channel Pixel-by-Pixel	YES	40 MSPS	MCLK max = 40MHz Minimum MCLK:VSMP ratio = 1:1	MONO = 1 TWOCHAN = 0	

Table 12 WM8224 16 bit Normal Operating Modes

## 10 BIT MODE

NUMBER OF CHANNELS	DESCRIPTION	CDS AVAILABLE	MAXIMUM SAMPLE RATE	TIMING REQUIREMENTS	REGISTER SETTINGS
9	3 Devices Used	YES	6.6 MSPS	MCLK max = 60MHz Minimum MCLK:VSMP ratio = 9:1	MONO = 0 TWOCHAN = 0 AUTOZ=1
					Dev ID   OPDEL[3:0]
					00   0000
					01   0100
6	2 Devices Used	YES	10 MSPS	MCLK max = 60MHz Minimum MCLK:VSMP ratio = 6:1	MONO = 0 TWOCHAN = 0 AUTOZ=1
					Dev ID   OPDEL[3:0]
					01   0100
3	Three channel Pixel-by-Pixel	YES	20 MSPS	MCLK max = 60MHz Minimum MCLK:VSMP ratio = 3:1	MONO = 0 TWOCHAN = 0
2	Two channel Pixel-by-Pixel	YES	30 MSPS	MCLK max = 60MHz Minimum MCLK:VSMP ratio = 2:1	MONO = 0 TWOCHAN = 1
1	One channel Pixel-by-Pixel	YES	60 MSPS	MCLK max = 60MHz Minimum MCLK:VSMP ratio = 1:1	MONO = 1 TWOCHAN = 0

Table 13 WM8224 10 bit Normal Operating Modes

Table 14 below shows the different channel mode register settings required to operate the 8224 in 1, 2 and 3 channel modes.

MONO	TWOCHAN	CHAN[1:0]	MODE DESCRIPTION
0	0	XX	3-channel (colour mode)
0	1	00	2-channel mode Green and Blue channels selected, Red PGA disabled
0	1	01	2-channel mode Red and Blue channels selected, Green PGA disabled
0	1	10	2-channel mode Red & Green channels selected, Blue PGA disabled
1	0	00	1-channel (monochrome) mode. Red channel selected, Green and Blue PGAs disabled.
1	0	01	1-channel (monochrome) mode. Green channel selected, Red and Blue PGAs disabled.
1	0	10	1-channel (monochrome) mode. Blue channel selected, Red and Green PGAs disabled.
X	X	11	Invalid mode
1	1	XX	Invalid mode

Table 14 Sampling Mode Summary

**Note:** Unused input pins should be connected to AGND unless reset level clamping is used.



## DEVICE CONFIGURATION

### REGISTER MAP

The following table describes the location of each control bit used to determine the operation of the WM8224.

ADDRESS <a5:a0>	DESCRIPTION	DEF (hex)	R W	BIT							
				b7	b6	b5	b4	b3	b2	b1	b0
000000 (00h)	Device ID	82	R	Reads first 2 digits of device part number							
000001 (01h)	Setup Reg 1	03	RW	ACLKDIV[1]	ACLKDIV[0]	PGAFS[1]	PGAFS[0]	TWOCHAN	MONO	CDS	EN
000010 (02h)	Setup Reg 2	E8	RW	RES[1]	RES[0]	RLCDACRNG	LOWREFS	OPD	INVOP	AUTOZ	OPFORM
000011 (03h)	Setup Reg 3	1F	RW	CHAN[1]	CHAN[0]	OEDEL[1]	OEDEL[0]	RLCDAC[3]	RLCDAC[2]	RLCDAC[1]	RLCCDAC[0]
000100 (04h)	Software Reset	24	RW	Reads second 2 digits of device part number							
000101 (05h)	Device ID Revision	01	R	Reads revision number of device							
000110 (06h)	Setup Reg 4	00	RW	OPDEL[3]	OPDEL[2]	OPDEL[1]	OPDEL[0]	0	0	0	0
000111 (07h)	Setup Reg 5	00	RW	0	0	ADCFEFPD	VRLCDACPD	ADCPD	BLUPD	GRNPD	REDPD
001000 (08h)	Setup Reg 6	20	RW	FOL_EN	CLAMPCTRL	RLCEN	0	0	0	0	0
001001 (09h)	BLC Red Target	00	RW	TARGETR[7]	TARGETR[6]	TARGETR[5]	TARGETR[4]	TARGETR[3]	TARGETR[2]	TARGETR[1]	TARGETR[0]
001010 (0Ah)	BLC Green Target	00	RW	TARGETG[7]	TARGETG[6]	TARGETG[5]	TARGETG[4]	TARGETG[3]	TARGETG[2]	TARGETG[1]	TARGETG[0]
001011 (0Bh)	BLC Blue Target	00	RW	TARGETB[7]	TARGETB[6]	TARGETB[5]	TARGETB[4]	TARGETB[3]	TARGETB[2]	TARGETB[1]	TARGETB[0]
001100 (0Ch)	BLC Control 1	00	RW	STATE_OUT	0	0	0	FSCALE_REL	TG_REG	TG_METHOD [1]	TG_METHOD [0]
001101 (0Dh)	BLC Control 2	00	RW	0	0	0	0	FA_EN	CADUR[2]	CADUR[1]	CADUR[0]
001110 (0Eh)	BLC Control 3	00	RW	BPIX_AVAIL [9]	BPIX_AVAIL [8]	CA_ EVERYLINE	FA_ EVERYLINE	FA_ACCUM	FRAME_SEQ	SEQ_START	FRAME_ START
001111 (0Fh)	BLC Control 4	00	RW	BPIX_AVAIL [7]	BPIX_AVAIL [6]	BPIX_AVAIL [5]	BPIX_AVAIL [4]	BPIX_AVAIL [3]	BPIX_AVAIL [2]	BPIX_AVAIL [1]	BPIX_AVAIL [0]
100000 (20h)	DAC Value (Red)	80	RW	DACR[7]	DACR[6]	DACR[5]	DACR[4]	DACR[3]	DACR[2]	DACR[1]	DACR[0]
100001 (21h)	DAC Value (Green)	80	RW	DACG[7]	DACG[6]	DACG[5]	DACG[4]	DACG[3]	DACG[2]	DACG[1]	DACG[0]
100010 (22h)	DAC Value (Blue)	80	RW	DACB[7]	DACB[6]	DACB[5]	DACB[4]	DACB[3]	DACB[2]	DACB[1]	DACB[0]
100011 (23h)	DAC Value (RGB)	80	W	DACRGB[7]	DACRGB[6]	DACRGB[5]	DACRGB[4]	DACRGB[3]	DACRGB[2]	DACRGB[1]	DACRGB[0]
100100 (24h)	PGA Gain LSB (Red)	00	RW	0	0	0	0	0	0	0	PGAR[0]
100101 (25h)	PGA Gain LSB (Green)	00	RW	0	0	0	0	0	0	0	PGAG[0]
100110 (26h)	PGA Gain LSB (Blue)	00	RW	0	0	0	0	0	0	0	PGAB[0]
100111 (27h)	PGA Gain LSB (RGB)	00	W	0	0	0	0	0	0	0	PGARGB[0]
101000 (28h)	PGA Gain MSBs (Red)	0C	RW	PGAR[8]	PGAR[7]	PGAR[6]	PGAR[5]	PGAR[4]	PGAR[3]	PGAR[2]	PGAR[1]
101001 (29h)	PGA Gain MSBs (Green)	0C	RW	PGAG[8]	PGAG[7]	PGAG[6]	PGAG[5]	PGAG[4]	PGAG[3]	PGAG[2]	PGAG[1]
101010 (2Ah)	PGA Gain MSBs (Blue)	0C	RW	PGAB[8]	PGAB[7]	PGAB[6]	PGAB[5]	PGAB[4]	PGAB[3]	PGAB[2]	PGAB[1]
101011 (2Bh)	PGA Gain MSBs (RGB)	0C	W	PGARGB[8]	PGARGB[7]	PGARGB[6]	PGARGB[5]	PGARGB[4]	PGARGB[3]	PGARGB[2]	PGARGB[1]
101100(2Ch)	BLC Control 5	00	RW	LINE_DEL[8]	BLC_DEL[6]	BLC_DEL[5]	BLC_DEL[4]	BLC_DEL[3]	BLC_DEL[2]	BLC_DEL[1]	BLC_DEL[0]
101101(2Dh)	BLC Control 6	00	RW	LINE_DEL[7]	LINE_DEL[6]	LINE_DEL[5]	LINE_DEL[4]	LINE_DEL[3]	LINE_DEL[2]	LINE_DEL[1]	LINE_DEL[0]

Table 15 Register Map

## REGISTER MAP DESCRIPTION

The following table describes the function of each of the control bits shown in Table 15.

REGISTER	REGISTER NAME	BIT NO	BIT NAME(S)	DEFAULT	DESCRIPTION
R0 (00h)	Device ID	7:0		10000010	Read only register. Reading from this register returns the first 2 digits of device part number.
R1 (01h)	Setup Register 1	0	EN	1	Global Enable 0 = complete power down, 1 = fully active (individual blocks can be disabled using individual powerdown bits – see setup register 5).
		1	CDS	1	Select correlated double sampling mode: 0 = non-CDS mode, 1 = CDS mode.
		2	MONO	0	Sampling mode select 0 = other mode (2 or 3-channel) 1 = Monochrome (1-channel) mode. Input channel selected by CHAN[1:0] register bits, unused channel is powered down. TWOCHAN and MONO should not be set concurrently.
		3	TWOCHAN	0	Sampling mode select 0 = other mode (1 or 3-channel) 1 = 2-channel mode. TWOCHAN and MONO should not be set concurrently.
		5:4	PGAFS[1:0]	00	Offsets PGA output to optimise the ADC range for different polarity sensor output signals. Zero differential PGA input signal gives: 0x = Zero output from the PGA (Output code=511) 10 = Full-scale positive output (OP=1023) – use for negative going video. NB, Set INVOP=1 if zero differential input should give a zero output code with negative going video. 11 = Full-scale negative output (OP=0) - use for positive going video
		7:6	ACLKDIV[1:0]	00	Reduces the internal clock frequency to allow analogue circuitry to run at a slower rate when daisy chaining devices. 00 – no divide 01 – divide MCLK by 2 internally 10 – divide MCLK by 3 internally 11 – not valid



REGISTER	REGISTER NAME	BIT NO	BIT NAME(S)	DEFAULT	DESCRIPTION
					00 = Red PGA disabled (G&B only)      10 = Blue PGA disabled (R&G only) 01 = Green PGA disabled (R&B only)      11 = Reserved
R4 (04h)	Software Reset	7:0		00100100	Any write to Software Reset causes all register bits to be reset. It is recommended that a software reset be performed after a power-up before any other register writes. Reading from this register returns the last 2 digits of the device part number.
R5 (05h)	Device ID Revision	7:0		00000001	Reading from this register returns the revision number of the device.
R6 (06h)	Setup Register 4	3:0	Reserved	0000	Must be set to 0000
		7:4	OPDEL[3:0]	000	Output latency adjust (ACLKDIV=00). 0000 = Minimum latency (7 MCLK periods) 0001 = 8 MCLK periods 0010 = 9 MCLK periods 0011 = 10 MCLK periods 0100 = 11 MCLK periods 0101 = 12 MCLK periods 0110 = 13 MCLK periods 0111 = 14 MCLK periods 1000 = 15 MCLK periods 1001 to 1111 = Invalid settings
R7 (07h)	Setup Register 5	0	REDPD	0	When set powers down red S/H, PGA
		1	GRNPD	0	When set powers down green S/H, PGA
		2	BLUPD	0	When set powers down blue S/H, PGA
		3	ADCPD	0	When set powers down ADC. Allows reduced power consumption without powering down the references which have a long time constant when switching on/off due to the external decoupling capacitors.
		4	VRLCDACPD	0	When set powers down 4-bit RLCDAC, setting the output to a high impedance state and allowing an external reference to be driven in on the VRLC/VBIAS pin.
		5	ADCREFPD	0	When set disables VRT, VRB buffers to allow external references to be used.
		7:6	Reserved	00	Must be set to 00
R8 (08h)	Setup Register 6	4:0	Reserved	00000	Must be set to 0
		5	RLCEN	1	Reset Level Clamp Enable. When set Reset Level Clamping is enabled. The method of clamping is determined by CLAMPCTRL.
		6	CLAMPCTRL	0	0 = RLC switch is controlled directly from RSMP input pin: RSMP = 0: switch is open RSMP = 1: switch is closed 1 = RLC switch is controlled by logical combination of RSMP and VSMP. RSMP && VSMP = 0: switch is open Switch is re-opened when: VSMP=0 (non-CDS mode) VSMP=0 and RSMP=0 (CDS mode)
		7	FOL_EN	0	Enables internal input voltage buffers, to minimise code drift if not pixel clamping, when using an ac coupling capacitor in non-CDS mode (CDS=0). Line clamping should be used when this bit is set.
R9 (09h)	BLC Red Target	7:0	TARGETR [7:0]	00000000	Target Black-Level code for Red channel. Please see the Target Codes Section for details.

REGISTER	REGISTER NAME	BIT NO	BIT NAME(S)	DEFAULT	DESCRIPTION
R10 (0Ah)	BLC Green Target	7:0	TARGETG [7:0]	00000000	Target Black-Level code for Green channel. Please see the Target Codes Section for details.
R11 (0Bh)	BLC Blue Target	7:2	TARGETB [7:0]	00000000	Target Black-Level code for Blue channel. Please see the Target Codes Section for details.
R12 (0Ch)	BLC Control 1	1:0	TG_METHOD [1:0]	00	Determines the start-of-line method to be used. 00 = TG_REG method 01 = Not a valid option 10 = OEB/TG shared pin method, +ve edge triggered 11 = OEB/TG shared pin method, -ve edge triggered
		2	TG_REG	0	Register flag to indicate a start-of-line, this register is automatically set to zero after it has been clocked by the BLC.
		3	FSCALE_REL	0	Inverts the Black-level target codes so they are relative to fullscale.
		4	RESERVED	0	Set to zero
		6:5	RESERVED	00	Set to zero
		7	STATE_OUT	0	Outputs the 2-bit state of the BLC onto OP0 and OP1.
R13 (0Dh)	BLC Control 2	2:0	CADUR[2:0]	000	Controls the number of Coarse Adjust iterations to be performed.
		3	FA_EN	0	Enables the Fine Adjust operation
		7:4	RESERVED	0000	Set to zero
R14 (0Eh)	BLC Control 3	0	FRAME_START	0	Register to indicate that the next start-of-line indicator is the first line in a frame. This register is automatically set to zero at the end of the BLC operation on the first line.
		1	SEQ_START	0	Register to indicate that the next start-of-line indicator is the first line of the first frame in a frame-sequence. This register is automatically set to zero at the end of the BLC operation on the first line.
		2	FRAME_SEQ	0	Indicates that the BLC is to be used in a sequence of frames
		3	FA_ACCUM	0	Makes the Fine Adjust calibration accumulate a result over multiple lines.
		4	FA_EVERYLINE	0	0 = Fine Adjust only used on the 1 <sup>st</sup> line of a frame 1 = Fine Adjust used on every line of a frame
		5	CA_EVERYLINE	0	0 = Coarse Adjust only used on the 1 <sup>st</sup> line of a frame 1 = Coarse Adjust used on every line of a frame
		7:6	BPIX_AVAIL [9:8]	00	MSBs of the number of Black-pixels available over which to perform the Coarse and/or Fine Adjust Calibration.
R15 (0Fh)	BLC Control 4	7:0	BPIX_AVAIL [7:0]	00000000	LSBs of the number of Black-pixels available over which to perform the Coarse and/or Fine Adjust Calibration.
R32 (20h)	Offset DAC (Red)	7:0	DACR[7:0]	10000000	Red channel 8-bit offset DAC value (mV) = $250 \cdot (\text{DACR}[7:0] - 127.5) / 127.5$
R33 (21h)	Offset DAC (Green)	7:0	DACG[7:0]	10000000	Green channel 8-bit offset DAC value (mV) = $250 \cdot (\text{DACG}[7:0] - 127.5) / 127.5$
R34 (22h)	Offset DAC (Blue)	7:0	DACB[7:0]	10000000	Blue channel 8-bit offset DAC value (mV) = $250 \cdot (\text{DACB}[7:0] - 127.5) / 127.5$
R35 (23h)	Offset DAC (RGB)	7:0	DACRGB[7:0]	-	A write to this register location causes the red, green and blue offset DAC registers to be overwritten by the new value
R36 (24h)	PGA Gain LSB (Red)	0	PGAR[0]	0	This register bit forms the LSB of the red channel PGA gain code. PGA gain is determined by combining this register bit and the 8 MSBs contained in register address 28 hex.
R37 (25h)	PGA Gain LSB (Green)	0	PGAG[0]	0	This register bit forms the LSB of the green channel PGA gain code. PGA gain is determined by combining this register bit and the 8 MSBs contained in register address 29 hex.

REGISTER	REGISTER NAME	BIT NO	BIT NAME(S)	DEFAULT	DESCRIPTION
R38 (26h)	PGA Gain LSB (Blue)	0	PGAB[0]	0	This register bit forms the LSB of the blue channel PGA gain code. PGA gain is determined by combining this register bit and the 8 MSBs contained in register address 2A hex.
R39 (27h)	PGA Gain LSB (RGB)	0	PGARGB[0]	-	Writing a value to this location causes red, green and blue PGA LSB gain values to be overwritten by the new value.
R40 (28h)	PGA gain MSBs (Red)	7:0	PGAR[8:1]	00001100	Bits 8 to 1 of red PGA gain. Combined with red LSB register bit to form complete PGA gain code. This determines the gain of the red channel PGA according to the equation: Red channel PGA gain (V/V) = 0.66 + PGAR[8:0]x7.34/511
R41 (29h)	PGA gain MSBs (Green)	7:0	PGAG[8:1]	00001100	Bits 8 to 1 of green PGA gain. Combined with green LSB register bit to form complete PGA gain code. This determines the gain of the green channel PGA according to the equation: Green channel PGA gain (V/V) = 0.66 + PGAG[8:0]x7.34/511
R42 (2Ah)	PGA gain MSBs (Blue)	7:0	PGAB[8:1]	00001100	Bits 8 to 1 of blue PGA gain. Combined with blue LSB register bit to form complete PGA gain code. This determines the gain of the blue channel PGA according to the equation: Blue channel PGA gain (V/V) = 0.66 + PGAB[8:0]x7.34/511
R43 (2Bh)	PGA gain MSBs (RGB)	7:0	PGARGB[8:1]	-	A write to this register location causes the red, green and blue PGA MSB gain registers to be overwritten by the new value.
R44 (2Ch)	BLC Control 5	6:0	BLC_DEL [6:0]	0000000	Determines the number of pixels (from the start of a line) to delay the start of a BLC operation.
		7	LINE_DEL [8]	0	MSB of the number of lines from the start of a frame to delay the start of a BLC operation.
R45 (2Dh)	BLC Control 6	7:0	LINE_DEL [7:0]	00000000	LSBs of the number of lines from the start of a frame to delay the start of a BLC operation.

Table 16 Register Control Bits

APPLICATIONS INFORMATION

RECOMMENDED EXTERNAL COMPONENTS

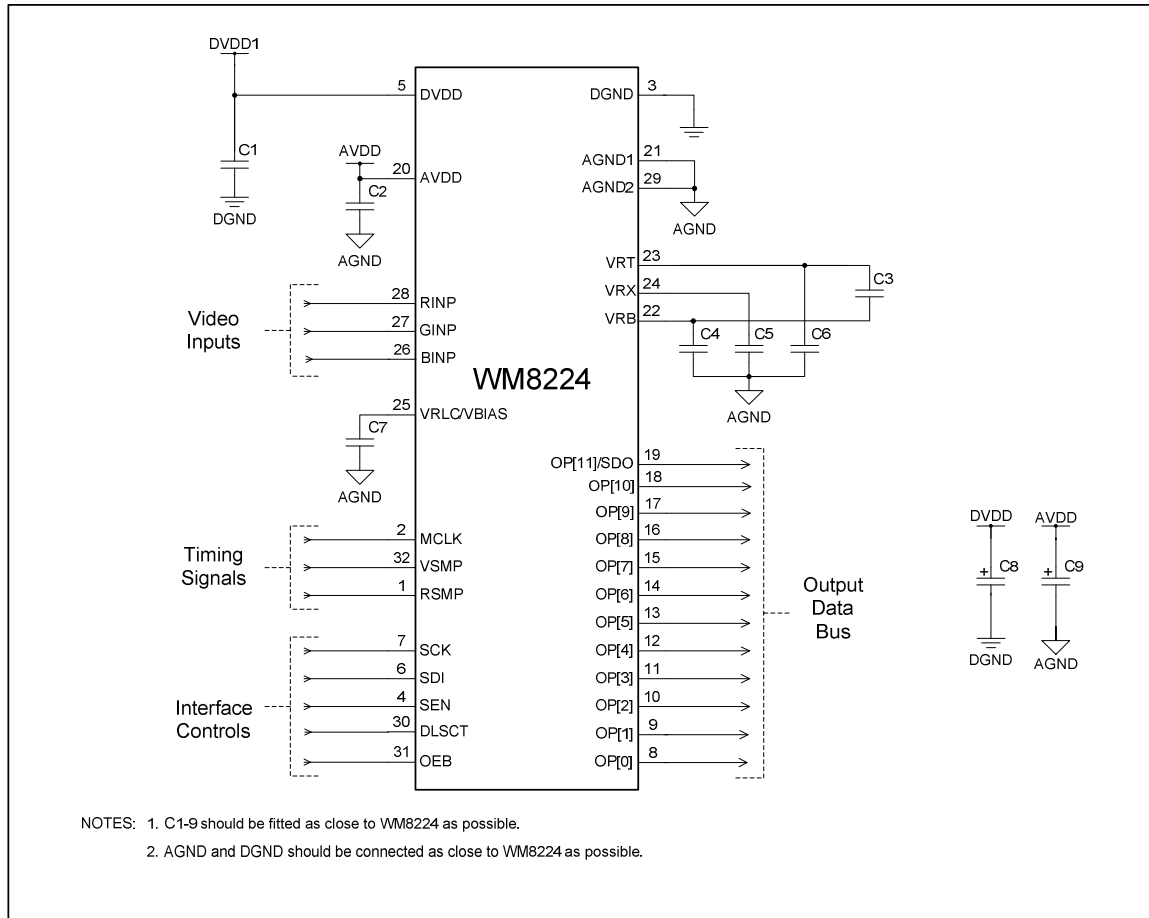

Figure 39 External Components Diagram

RECOMMENDED EXTERNAL COMPONENT VALUES

COMPONENT REFERENCE	SUGGESTED VALUE	DESCRIPTION
C1	100nF	De-coupling for DVDD
C2	100nF	De-coupling for AVDD
C3	1 $\mu$ F	Ceramic de-coupling between VRT and VRB (non polarized)
C4	100nF	De-coupling for VRB
C5	100nF	De-coupling for VRX
C6	100nF	De-coupling for VRT
C7	100nF	De-coupling for VRLC
C8	10 $\mu$ F	Reservoir capacitor for DVDD
C9	10 $\mu$ F	Reservoir capacitor for AVDD

Table 17 External Components Descriptions

PACKAGE DIMENSIONS

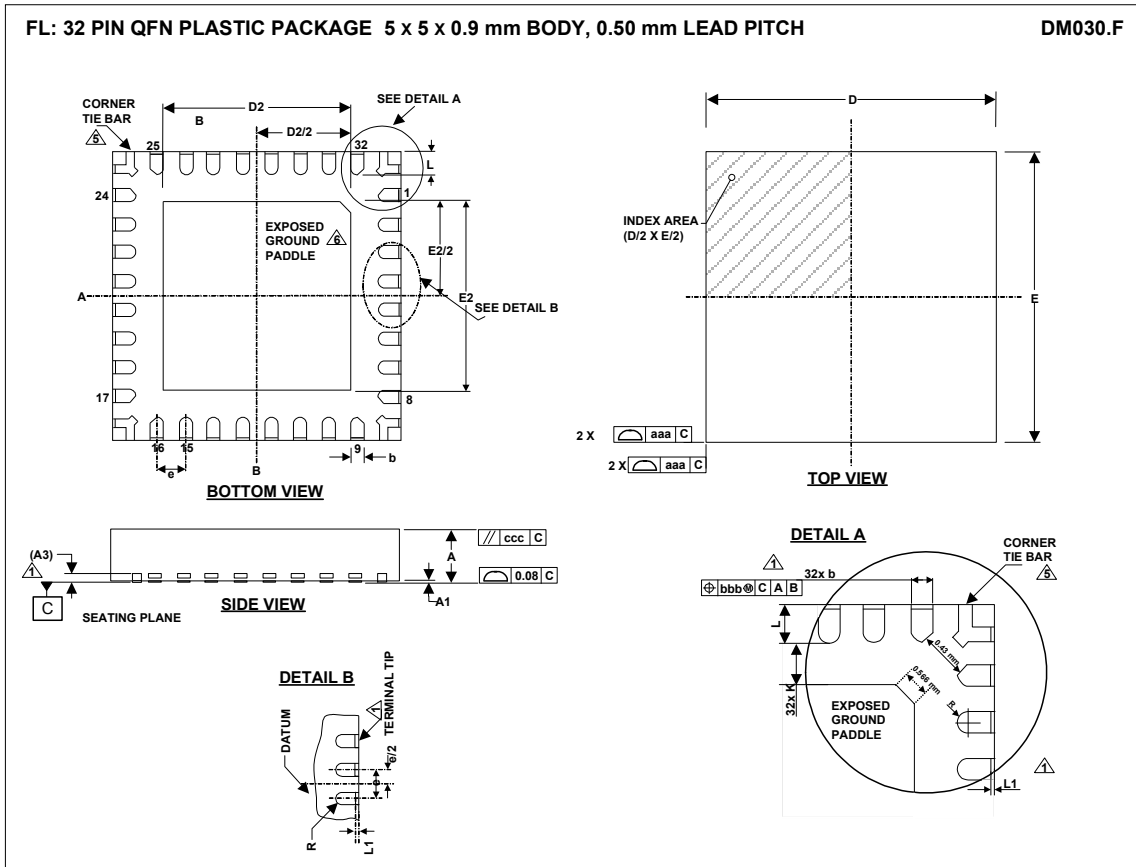

Symbols	Dimensions (mm)			NOTE
	MIN	NOM	MAX	
A	0.85	0.90	1.00	
A1	0	0.02	0.05	
A3		0.2 REF		
b	0.18	0.23	0.30	1
D		5.00 BSC		
D2	3.2	3.3	3.4	2
E		5.00 BSC		
E2	3.2	3.3	3.4	2
e		0.5 BSC		
L	0.35	0.4	0.45	
L1			0.1	1
R	b(min)/2			
K	0.20			
<b>Tolerances of Form and Position</b>				
aaa		0.15		
bbb		0.10		
ccc		0.10		
REF:	JEDEC, MO-220, VARIATION VHHD-2			

- NOTES:
- DIMENSION b APPLIED TO METALLIZED TERMINAL AND IS MEASURED BETWEEN 0.25 mm AND 0.30 mm FROM TERMINAL TIP. DIMENSION L1 REPRESENTS TERMINAL PULL BACK FROM PACKAGE SIDE WALL. MAXIMUM OF 0.1mm IS ACCEPTABLE. WHERE TERMINAL PULL BACK EXISTS, ONLY UPPER HALF OF LEAD IS VISIBLE ON PACKAGE SIDE WALL DUE TO HALF ETCHING OF LEADFRAME.
  - FALLS WITHIN JEDEC, MO-220 WITH THE EXCEPTION OF D2, E2:  
D2, E2: LARGER PAD SIZE CHOSEN WHICH IS JUST OUTSIDE JEDEC SPECIFICATION
  - ALL DIMENSIONS ARE IN MILLIMETRES
  - THIS DRAWING IS SUBJECT TO CHANGE WITHOUT NOTICE.
  - SHAPE AND SIZE OF CORNER TIE BAR MAY VARY WITH PACKAGE TERMINAL COUNT. CORNER TIE BAR IS CONNECTED TO EXPOSED PAD INTERNALLY.
  - REFER TO APPLICATION NOTE WAN\_0118 FOR FURTHER INFORMATION REGARDING PCB FOOTPRINTS AND QFN PACKAGE SOLDERING.



## IMPORTANT NOTICE

Wolfson Microelectronics plc ("Wolfson") products and services are sold subject to Wolfson's terms and conditions of sale, delivery and payment supplied at the time of order acknowledgement.

Wolfson warrants performance of its products to the specifications in effect at the date of shipment. Wolfson reserves the right to make changes to its products and specifications or to discontinue any product or service without notice. Customers should therefore obtain the latest version of relevant information from Wolfson to verify that the information is current.

Testing and other quality control techniques are utilised to the extent Wolfson deems necessary to support its warranty. Specific testing of all parameters of each device is not necessarily performed unless required by law or regulation.

In order to minimise risks associated with customer applications, the customer must use adequate design and operating safeguards to minimise inherent or procedural hazards. Wolfson is not liable for applications assistance or customer product design. The customer is solely responsible for its selection and use of Wolfson products. Wolfson is not liable for such selection or use nor for use of any circuitry other than circuitry entirely embodied in a Wolfson product.

Wolfson's products are not intended for use in life support systems, appliances, nuclear systems or systems where malfunction can reasonably be expected to result in personal injury, death or severe property or environmental damage. Any use of products by the customer for such purposes is at the customer's own risk.

Wolfson does not grant any licence (express or implied) under any patent right, copyright, mask work right or other intellectual property right of Wolfson covering or relating to any combination, machine, or process in which its products or services might be or are used. Any provision or publication of any third party's products or services does not constitute Wolfson's approval, licence, warranty or endorsement thereof. Any third party trade marks contained in this document belong to the respective third party owner.

Reproduction of information from Wolfson datasheets is permissible only if reproduction is without alteration and is accompanied by all associated copyright, proprietary and other notices (including this notice) and conditions. Wolfson is not liable for any unauthorised alteration of such information or for any reliance placed thereon.

Any representations made, warranties given, and/or liabilities accepted by any person which differ from those contained in this datasheet or in Wolfson's standard terms and conditions of sale, delivery and payment are made, given and/or accepted at that person's own risk. Wolfson is not liable for any such representations, warranties or liabilities or for any reliance placed thereon by any person.

### ADDRESS:

Wolfson Microelectronics plc  
Westfield House  
26 Westfield Road  
Edinburgh  
EH11 2QB

Tel :: +44 (0)131 272 7000

Fax :: +44 (0)131 272 7001

Email :: [sales@wolfsonmicro.com](mailto:sales@wolfsonmicro.com)