

## Stereo CODEC with Headphone Driver and Line Out

### DESCRIPTION

The WM8758B is a low power, high quality stereo CODEC designed for portable applications such as MP3 audio player.

The device integrates preamps for stereo differential mics, and drivers for headphone and differential or stereo line output. External component requirements are reduced as no separate microphone or headphone amplifiers are required. Headphone and line common feedback improves crosstalk and noise performance.

Advanced on-chip digital signal processing includes a 5-band equaliser, a mixed signal Automatic Level Control for the microphone or line input through the ADC as well as a purely digital limiter function for record or playback. Additional digital filtering options are available in the ADC path, to cater for application filtering such as 'wind noise reduction' and notch filter.

The WM8758B digital audio interface can operate in master or slave mode with an integrated PLL.

The WM8758B operates at analogue supply voltages from 2.5V to 3.3V, although the digital supply voltages can operate at voltages down to 1.71V to save power. Additional power management control enables individual sections of the chip to be powered down under software control.

### FEATURES

#### Stereo CODEC:

- DAC SNR 100dB, THD -86dB ('A' weighted @ 48kHz)
- ADC SNR 92.5dB, THD -75dB ('A' weighted @ 48kHz)
- Headphone Driver
- 40mW per channel output power into 16Ω / 3.3V AVDD2
- Line output

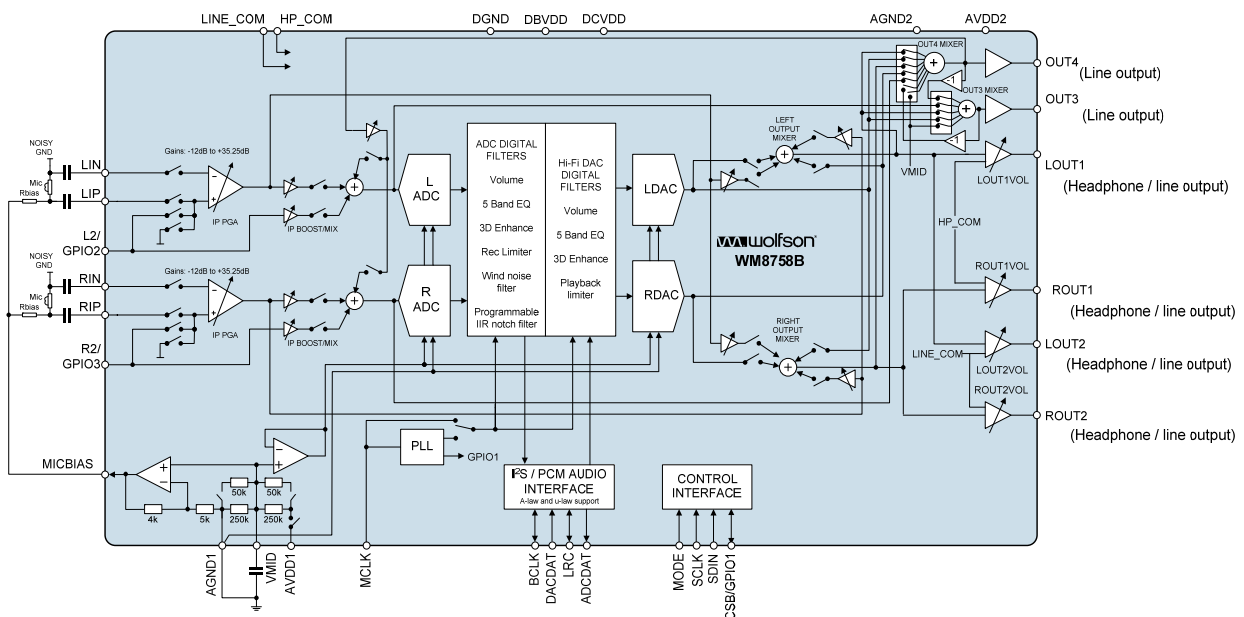
#### Mic Preamps:

- Stereo Differential or mono microphone Interfaces
- Programmable preamp gain
- Pseudo differential inputs with common mode rejection
- Programmable ALC / Noise Gate in ADC path
- Low-noise bias supplied for electret microphones

#### Other Features:

- Enhanced 3-D function for improved stereo separation
- Digital playback limiter
- 5-band Equaliser (record or playback)
- Programmable ADC High Pass Filter (wind noise reduction)
- Programmable ADC Notch Filter
- PLL supporting various clocks between 8MHz-50MHz
- Sample rates supported (kHz): 8, 11.025, 12, 16, 22.05, 24, 32, 44.1, 48
- Low power, low voltage
- 2.5V to 3.6V analogue supplies
- 1.71V to 3.6V digital supplies
- 5x5mm 32-lead QFN package

### BLOCK DIAGRAM



### APPLICATIONS

- Portable audio player

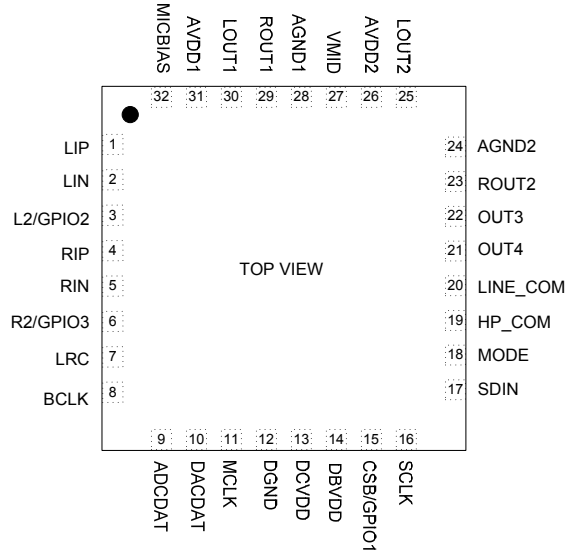
## TABLE OF CONTENTS

<b>DESCRIPTION</b> .....	<b>1</b>
<b>BLOCK DIAGRAM</b> .....	<b>1</b>
<b>FEATURES</b> .....	<b>1</b>
<b>APPLICATIONS</b> .....	<b>1</b>
<b>TABLE OF CONTENTS</b> .....	<b>2</b>
<b>PIN CONFIGURATION</b> .....	<b>4</b>
<b>ORDERING INFORMATION</b> .....	<b>4</b>
<b>PIN DESCRIPTION</b> .....	<b>5</b>
<b>RECOMMENDED OPERATING CONDITIONS</b> .....	<b>6</b>
<b>ELECTRICAL CHARACTERISTICS</b> .....	<b>7</b>
TERMINOLOGY .....	12
<b>HEADPHONE OUTPUT PERFORMANCE</b> .....	<b>13</b>
<b>POWER CONSUMPTION</b> .....	<b>14</b>
<b>AUDIO PATHS OVERVIEW</b> .....	<b>15</b>
<b>SIGNAL TIMING REQUIREMENTS</b> .....	<b>16</b>
SYSTEM CLOCK TIMING .....	16
AUDIO INTERFACE TIMING – MASTER MODE.....	16
AUDIO INTERFACE TIMING – SLAVE MODE .....	17
CONTROL INTERFACE TIMING – 3-WIRE MODE.....	18
CONTROL INTERFACE TIMING – 2-WIRE MODE.....	19
<b>INTERNAL POWER ON RESET CIRCUIT</b> .....	<b>20</b>
RECOMMENDED POWER UP/DOWN SEQUENCE.....	22
<b>DEVICE DESCRIPTION</b> .....	<b>25</b>
INTRODUCTION .....	25
INPUT SIGNAL PATH .....	26
ANALOGUE TO DIGITAL CONVERTER (ADC) .....	33
INPUT LIMITER / AUTOMATIC LEVEL CONTROL (ALC).....	37
OUTPUT SIGNAL PATH .....	42
3D STEREO ENHANCEMENT.....	49
ANALOGUE OUTPUTS.....	49
DIGITAL AUDIO INTERFACES.....	61
AUDIO SAMPLE RATES .....	68
MASTER CLOCK AND PHASE LOCKED LOOP (PLL).....	68
GENERAL PURPOSE INPUT/OUTPUT.....	70
OUTPUT SWITCHING (JACK DETECT).....	72
CONTROL INTERFACE.....	73
RESETTING THE CHIP .....	74
POWER SUPPLIES.....	75
POWER MANAGEMENT .....	75
POP MINIMISATION .....	77
<b>REGISTER MAP</b> .....	<b>78</b>
<b>DIGITAL FILTER CHARACTERISTICS</b> .....	<b>80</b>
TERMINOLOGY .....	80
DAC FILTER RESPONSES .....	81
ADC FILTER RESPONSES .....	81
HIGHPASS FILTER.....	82
5-BAND EQUALISER.....	83

---

<b>APPLICATIONS INFORMATION</b> .....	<b>87</b>
RECOMMENDED EXTERNAL COMPONENTS .....	87
<b>PACKAGE DIAGRAM</b> .....	<b>88</b>
<b>IMPORTANT NOTICE</b> .....	<b>89</b>
ADDRESS: .....	89

**PIN CONFIGURATION**



**ORDERING INFORMATION**

ORDER CODE	TEMPERATURE RANGE	PACKAGE	MOISTURE SENSITIVITY LEVEL	PEAK SOLDERING TEMPERATURE
WM8758CBGEFL/V	-40°C to +85°C	32-lead QFN (5 x 5 mm) (Pb-free)	MSL3	260°C
WM8758CBGEFL/RV	-40°C to +85°C	32-lead QFN (5 x 5 mm) (Pb-free, tape and reel)	MSL3	260°C

**Note:**

Reel quantity = 3,500

**PIN DESCRIPTION**

PIN	NAME	TYPE	DESCRIPTION
1	LIP	Analogue Input	Left MIC pre-amp positive input
2	LIN	Analogue Input	Left MIC pre-amp negative input
3	L2/GPIO2	Analogue Input	Left channel line input/secondary mic pre-amp positive input/GPIO2 pin
4	RIP	Analogue Input	Right MIC pre-amp positive input
5	RIN	Analogue Input	Right MIC pre-amp negative input
6	R2/GPIO3	Analogue Input	Right channel line input/secondary mic pre-amp positive input/GPIO3 pin
7	LRC	Digital Input / Output	DAC and ADC sample rate clock
8	BCLK	Digital Input / Output	Digital audio bit clock
9	ADCDAT	Digital Output	ADC digital audio data output
10	DACDAT	Digital Input	DAC digital audio data input
11	MCLK	Digital Input	Master clock input
12	DGND	Supply	Digital ground
13	DCVDD	Supply	Digital core logic supply
14	DBVDD	Supply	Digital buffer (I/O) supply
15	CSB/GPIO1	Digital Input / Output	3-Wire control interface chip select / GPIO1 pin
16	SCLK	Digital Input	3-Wire control interface clock input / 2-wire control interface clock input
17	SDIN	Digital Input / Output	3-Wire control interface data input / 2-Wire control interface data input
18	MODE	Digital Input	Control interface selection
19	HP_COM	Analogue Input	Headphone ground common feedback input
20	LINE_COM	Analogue Input	Line out ground common feedback input
21	OUT4	Analogue Output	Right line output / mono mix output
22	OUT3	Analogue Output	Left line output / mono mix output
23	ROUT2	Analogue Output	Line output right 2
24	AGND2	Supply	Analogue ground (return path for ROUT2/LOUT2)
25	LOUT2	Analogue Output	Line output left 2
26	AVDD2	Supply	Analogue supply (supply for output amplifiers ROUT2/LOUT2)
27	VMID	Reference	Decoupling for ADC and DAC reference voltage
28	AGND1	Supply	Analogue ground (return path for all input amplifiers, PLL, ADC and DAC, internal bias circuits, output amplifiers LOUT1, ROUT1 and OUT3/OUT4 on AVDD1 AGND1)
29	ROUT1	Analogue Output	Line or headphone output right 1
30	LOUT1	Analogue Output	Line or headphone output left 1
31	AVDD1	Supply	Analogue supply (feeds all input amplifiers, PLL, ADC and DAC, internal bias circuits, output amplifiers LOUT1, ROUT1))
32	MICBIAS	Analogue Output	Microphone bias

**Note:**

It is recommended that the QFN ground paddle should be connected to analogue ground on the application PCB.

## ABSOLUTE MAXIMUM RATINGS

Absolute Maximum Ratings are stress ratings only. Permanent damage to the device may be caused by continuously operating at or beyond these limits. Device functional operating limits and guaranteed performance specifications are given under Electrical Characteristics at the test conditions specified.



ESD Sensitive Device. This device is manufactured on a CMOS process. It is therefore generically susceptible to damage from excessive static voltages. Proper ESD precautions must be taken during handling and storage of this device.

Wolfson tests its package types according to IPC/JEDEC J-STD-020B for Moisture Sensitivity to determine acceptable storage conditions prior to surface mount assembly. These levels are:

MSL1 = unlimited floor life at <30°C / 85% Relative Humidity. Not normally stored in moisture barrier bag.

MSL2 = out of bag storage for 1 year at <30°C / 60% Relative Humidity. Supplied in moisture barrier bag.

MSL3 = out of bag storage for 168 hours at <30°C / 60% Relative Humidity. Supplied in moisture barrier bag.

The Moisture Sensitivity Level for each package type is specified in Ordering Information.

CONDITION	MIN	MAX
DBVDD, DCVDD, AVDD1, AVDD2 supply voltages	-0.3V	+3.63V
Voltage range digital inputs	DGND -0.3V	DVDD +0.3V
Voltage range analogue inputs	AGND1 -0.3V	AVDD1 +0.3V
Storage temperature prior to soldering	30°C max / 85% RH max	
Storage temperature after soldering	-65°C	+150°C

### Notes

1. Analogue and digital grounds must always be within 0.3V of each other.
2. All digital and analogue supplies are internally independent (i.e. not connected).
3. Analogue supply voltages should not be less than digital supply voltages.
4. DBVDD must be greater than or equal to DCVDD.

## RECOMMENDED OPERATING CONDITIONS

PARAMETER	SYMBOL	TEST CONDITIONS	MIN	TYP	MAX	UNIT
Digital supply range (Core)	DCVDD		1.71 <sup>1,2</sup>	1.8	3.6	V
Digital supply range (Buffer)	DBVDD		1.71	3.3	3.6	V
Analogue supply range	AVDD1, AVDD2		2.5 <sup>1</sup>	3.3	3.6	V
Ground	DGND, AGND1, AGND2			0		V

### Notes

1. Analogue supply voltages must not be less than digital supply voltages.
2. DBVDD must be greater than or equal to DCVDD.

## ELECTRICAL CHARACTERISTICS

### Test Conditions

DCVDD=1.8V, AVDD1=AVDD2=3.0V, DBVDD=3.3V, T<sub>A</sub> = +25°C, 1kHz signal, fs = 48kHz, 24-bit audio data unless otherwise stated.

PARAMETER	SYMBOL	TEST CONDITIONS	MIN	TYP	MAX	UNIT
<b>Microphone Preamp Inputs (LIP, LIN, RIP, RIN, L2, R2)</b>						
Full-scale Input Signal Level – Single-ended input via LIN/RIN	V <sub>INFS</sub>	PGABOOST = 0dB INPPGAVOL = 0dB		AVDD1/3.3		V <sub>rms</sub>
Full-scale Input Signal Level – Pseudo-differential input	V <sub>INFS</sub>	PGABOOST = 0dB INPPGAVOL = 0dB		AVDD1*0.7/ 3.3		V <sub>rms</sub>
Mic PGA equivalent input noise	At 35.25dB gain	0 to 20kHz		150		uV
Input resistance (LIN, RIN)	R <sub>MICIN</sub>	Gain set to 35.25dB		1.6		kΩ
Input resistance (LIN, RIN)	R <sub>MICIN</sub>	Gain set to 0dB		46		kΩ
Input resistance (LIN, RIN)	R <sub>MICIN</sub>	Gain set to -12dB		71		kΩ
Input resistance (LIP, RIP)	R <sub>MICIP</sub>			90		kΩ
Input resistance (L2, R2)	R <sub>L2R2</sub>	L/RIP2INPPGA = 1, L/R2_2BOOSTVOL = 000		90		kΩ
Input resistance (L2, R2)	R <sub>L2R2</sub>	L/RIP2INPPGA = 0, Gain set to 6dB		11		kΩ
Input resistance (L2, R2)	R <sub>L2R2</sub>	L/RIP2INPPGA = 0, Gain set to 0dB		22		kΩ
Input resistance (L2, R2)	R <sub>L2R2</sub>	L/RIP2INPPGA = 0, Gain set to -12dB		60		kΩ
Input Capacitance	C <sub>MICIN</sub>			10		pF
Maximum Programmable Gain				+35.25		dB
Minimum Programmable Gain				-12		dB
Programmable Gain Step Size		Guaranteed monotonic		0.75		dB
MIC Mute Attenuation		INPPGAMUTEL/R=1		100		dB
MIC Gain Boost		PGABOOSTL/R=0		0		dB
		PGABOOSTL/R=1		20		dB
<b>L2, R2 Line Input Programmable Gain</b>						
Maximum Gain from L/R2 input to boost/mixer		Gain adjusted by L2_2BOOSTVOL R2_2BOOSTVOL		+6		dB
Minimum Gain from L/R2 input to boost/mixer		Gain adjusted by L2_2BOOSTVOL R2_2BOOSTVOL		-12		dB
L2/R2 boost step size		Guaranteed monotonic		3		dB
L2/R2 Mute attenuation				100		dB
<b>OUT4 to Left or Right Input Boost Record Path</b>						
Maximum Gain				+6		dB
Minimum Gain				-12		dB
Gain step size		Guaranteed monotonic		3		dB
Mute attenuation				100		dB
<b>Automatic Level Control (ALC)</b>						
Target Record Level			-22.5		-1.5	dB
Programmable gain			-12		35.25	

**Test Conditions**

DCVDD=1.8V, AVDD1=AVDD2=3.0V, DBVDD=3.3V, T<sub>A</sub> = +25°C, 1kHz signal, fs = 48kHz, 24-bit audio data unless otherwise stated.

PARAMETER	SYMBOL	TEST CONDITIONS	MIN	TYP	MAX	UNIT
<b>Analogue to Digital Converter (ADC) - Input from LIN/P and RIN/P, PGA and boost gains=0dB</b>						
Signal to Noise Ratio (Note 5,6)	SNR	A-weighted AVDD1=AVDD2=3.0V		92.5		dB
		A-weighted AVDD1=AVDD2=2.5V		91.5		dB
		22Hz to 20kHz AVDD1=AVDD2=3.0V		90		dB
		22Hz to 20kHz AVDD1=AVDD2=2.5V		90		dB
Total Harmonic Distortion (Note 7)	THD	-12dBFS Input AVDD1=AVDD2=3.0V		-75		dB
		-12dBFS Input AVDD1=AVDD2=2.5V		-75		dB
Total Harmonic Distortion + Noise (Note 7)	THD+N	-12dBFS Input AVDD1=AVDD2=3.0V		-72		dB
		-12dBFS Input AVDD1=AVDD2=2.5V		-72		dB
Channel Separation (Note 8)		1kHz full scale input signal		100		dB
<b>Analogue to Digital Converter (ADC) - Input from L2, R2</b>						
Signal to Noise Ratio (Note 5,6)	SNR	A-weighted AVDD1=AVDD2=3.0V	85	92.5		dB
		A-weighted AVDD1=AVDD2=2.5V		92.5		dB
		22Hz to 20kHz AVDD1=AVDD2=3.0V		90		dB
		22Hz to 20kHz AVDD1=AVDD2=2.5V		90		dB
Total Harmonic Distortion (Note 7)	THD	-3dBFS Input AVDD1=AVDD2=3.0V		-83	-75	dB
		-3dBFS Input AVDD1=AVDD2=2.5V		-66		dB
Total Harmonic Distortion + Noise (Note 7)	THD+N	-3dBFS Input AVDD1=AVDD2=3.0V		-81	-70	dB
		-3dBFS Input AVDD1=AVDD2=2.5V		-65		dB
Channel Separation (Note 8)		1kHz input signal		100		dB



**Test Conditions**

DCVDD=1.8V, AVDD1=AVDD2=3.0V, DBVDD=3.3V, T<sub>A</sub> = +25°C, 1kHz signal, fs = 48kHz, 24-bit audio data unless otherwise stated.

PARAMETER	SYMBOL	TEST CONDITIONS	MIN	TYP	MAX	UNIT
<b>DAC to L/R Mix to Line-Out (LOUT1/ROUT1 with 10kΩ / 50pF load, analogue volume controls set to 0dB)</b>						
Full-scale output		PGA gains set to 0dB		AVDD1/3.3		Vrms
Signal to Noise Ratio (Note 5,6)	SNR	A-weighted AVDD1=AVDD2=3.0V		100		dB
		A-weighted AVDD1=AVDD2=2.5V		96		dB
		22Hz to 20kHz AVDD1=AVDD2=3.0V		95.5		dB
		22Hz to 20kHz AVDD1=AVDD2=2.5V		93.5		dB
Total Harmonic Distortion (Note 7)	THD	full-scale signal AVDD1=AVDD2=3.0V		-86		dB
		full-scale signal AVDD1=AVDD2=2.5V		-86		dB
Total Harmonic Distortion + Noise (Note 7)	THD+N	full-scale signal AVDD1=AVDD2=3.0V		-84		dB
		full-scale signal AVDD1=AVDD2=2.5V		-84		dB
Channel Separation (Note 8)		1kHz signal		100		dB
Ground noise rejection		10mV, 20kHz noise on HPCOM, HPCOM enabled		40		dB
<b>DAC to L/R Mix to Line-Out (LOUT2/ROUT2 with 10kΩ / 50pF load, analogue volume controls set to 0dB)</b>						
Full-scale output		PGA gains set to 0dB		AVDD1/3.3		Vrms
Signal to Noise Ratio (Note 5,6)	SNR	A-weighted AVDD1=AVDD2=3.0V	95	100		dB
		A-weighted AVDD1=AVDD2=2.5V		96		dB
		22Hz to 20kHz AVDD1=AVDD2=3.0V		95.5		dB
		22Hz to 20kHz AVDD1=AVDD2=2.5V		93.5		dB
Total Harmonic Distortion (Note 7)	THD	full-scale signal AVDD1=AVDD2=3.0V		-87	-80	dB
		full-scale signal AVDD1=AVDD2=2.5V		-82		dB
Total Harmonic Distortion + Noise (Note 7)	THD+N	full-scale signal AVDD1=AVDD2=3.0V		-85	-75	dB
		full-scale signal AVDD1=AVDD2=2.5V		-80		dB
Channel Separation (Note 8)		1kHz signal		100		dB
Ground noise rejection		10mV, 20kHz noise on LCOM, LCOM enabled		40		dB

**Test Conditions**

DCVDD=1.8V, AVDD1=AVDD2=3.0V, DBVDD=3.3V, T<sub>A</sub> = +25°C, 1kHz signal, fs = 48kHz, 24-bit audio data unless otherwise stated.

PARAMETER	SYMBOL	TEST CONDITIONS	MIN	TYP	MAX	UNIT
<b>DAC to L/R Mix to Headphone (LOUT1/ROUT1, analogue volume controls set to 0dB)</b>						
Full-scale output		PGA gains set to 0dB		AVDD1/3.3		Vrms
Signal to Noise Ratio (Note 5,6)	SNR	A-weighted		100		dB
		22Hz to 20kHz		95.5		dB
Total Harmonic Distortion (Note 7)	THD	P <sub>o</sub> = 20mW RL=16Ω		-75		dB
		P <sub>o</sub> = 20mW RL=32Ω		-79		dB
Total Harmonic Distortion + Noise (Note 7)	THD+N	P <sub>o</sub> = 20mW RL=16Ω		-75		dB
		P <sub>o</sub> = 20mW RL=32Ω		-79		dB
Channel Separation (Note 8)		1kHz signal		100		dB
Ground noise rejection		10mV, 20kHz noise on HPCOM, HPCOM enabled		40		dB
<b>DAC to L/R Mix to Headphone (LOUT2/ROUT2, analogue volume controls set to 0dB)</b>						
Full-scale output		PGA gains set to 0dB		AVDD1/3.3		Vrms
Signal to Noise Ratio (Note 5,6)	SNR	A-weighted	90	97		dB
		22Hz to 20kHz		95.5		dB
Total Harmonic Distortion (Note 7)	THD	P <sub>o</sub> = 20mW RL=16Ω		-79		dB
		P <sub>o</sub> = 20mW RL=32Ω		-82		dB
Channel Separation (Note 8)		1kHz signal		100		dB
Ground noise rejection		10mV, 20kHz noise on LCOM, LCOM enabled		40		dB
<b>Bypass Paths to Output Mixers</b>						
Maximum PGA gain into mixer				+6		dB
Minimum PGA gain into mixer				-15		dB
PGA gain step into mixer		Guaranteed monotonic		3		dB
Mute attenuation				100		dB
<b>Analogue Outputs (LOUT1, ROUT1, LOUT2, ROUT2)</b>						
Maximum Programmable Gain				+6		dB
Minimum Programmable Gain				-57		dB
Programmable Gain step size		Guaranteed monotonic		1		dB
Mute attenuation		1kHz, full scale signal		85		dB

**Test Conditions**

DCVDD=1.8V, AVDD1=AVDD2=3.0V, DBVDD=3.3V, T<sub>A</sub> = +25°C, 1kHz signal, fs = 48kHz, 24-bit audio data unless otherwise stated.

PARAMETER	SYMBOL	TEST CONDITIONS	MIN	TYP	MAX	UNIT
<b>MIC PGA to Input Boost to OUT3/OUT4 outputs (with 10kΩ / 50pF load)</b>						
Full-scale output voltage, 0dB gain (Note 9)				AVDD2/3.3		Vrms
Signal to Noise Ratio (Note 5,6)	SNR	A-weighted AVDD1=AVDD2=3.0V	90	98		dB
		A-weighted AVDD1=AVDD2=2.5V		96		dB
		22Hz to 22kHz AVDD1=AVDD2=3.0V		95.5		dB
		22Hz to 22kHz AVDD1=AVDD2=2.5V		93.5		dB
Total Harmonic Distortion (Note 7)	THD	full-scale signal AVDD1=AVDD2=3.0V		-84		dB
		full-scale signal AVDD1=AVDD2=2.5V		-82		dB
Total Harmonic Distortion + Noise (Note 7)	THD+N	full-scale signal AVDD1=AVDD2=3.0V		-82		dB
		full-scale signal AVDD1=AVDD2=2.5V		-80		dB
Channel Separation				100		dB
<b>MIC PGA Bypass to LOUT1/ROUT1 (with 16Ω load)</b>						
Full-scale output voltage, 0dB gain (Note 9)				AVDD1/3.3		Vrms
Signal to Noise Ratio (Note 5,6)	SNR	A-weighted AVDD1=AVDD2=3.0V	90	100		dB
		A-weighted AVDD1=AVDD2=2.5V		96		dB
		22Hz to 22kHz AVDD1=AVDD2=3.0V		95.5		dB
		22Hz to 22kHz AVDD1=AVDD2=2.5V		93.5		dB
Total Harmonic Distortion (Note 7)	THD	-5dBFS signal AVDD1=AVDD2=3.0V		-87	-75	dB
		-5dBFS signal AVDD1=AVDD2=2.5V		-69		dB
Total Harmonic Distortion + Noise (Note 7)	THD+N	-5dBFS signal AVDD1=AVDD2=3.0V		-85	-73	dB
		-5dBFS signal AVDD1=AVDD2=2.5V		-68		dB
Channel separation		1kHz full scale signal		100		dB

**Test Conditions**

DCVDD=1.8V, AVDD1=AVDD2=3.0V, DBVDD=3.3V, T<sub>A</sub> = +25°C, 1kHz signal, fs = 48kHz, 24-bit audio data unless otherwise stated.

PARAMETER	SYMBOL	TEST CONDITIONS	MIN	TYP	MAX	UNIT
<b>Microphone Bias</b>						
Bias Voltage	V <sub>MICBIAS</sub>	MBVSEL=0		0.9*AVDD1		V
		MBVSEL=1		0.65*AVDD1		V
Bias Current Source	I <sub>MICBIAS</sub>	for V <sub>MICBIAS</sub> within +/-3%			3	mA
Output Noise Voltage	V <sub>n</sub>	1kHz to 20kHz		15		nV/√Hz
<b>Digital Input / Output</b>						
Input HIGH Level	V <sub>IH</sub>		0.7×DBVDD			V
Input LOW Level	V <sub>IL</sub>				0.3×DBVDD	V
Output HIGH Level	V <sub>OH</sub>	I <sub>OL</sub> =1mA	0.9×DBVDD			V
Output LOW Level	V <sub>OL</sub>	I <sub>OH</sub> =1mA			0.1×DBVDD	V

**TERMINOLOGY**

1. Signal-to-noise ratio (dB) – SNR is a measure of the difference in level between the full scale output and the output with no signal applied. (No Auto-zero or Automute function is employed in achieving these results).
2. THD+N (dB) – THD+N is a ratio, of the rms values, of (Noise + Distortion)/Signal.
3. Channel Separation (dB) – Also known as Cross-Talk. This is a measure of the amount one channel is isolated from the other. Normally measured by sending a full scale signal down one channel and measuring the other.
4. THD (dB) – THD is a ratio of the rms value of the first seven harmonics compared to the rms value of the fundamental.

## HEADPHONE OUTPUT PERFORMANCE

### SNR Graphs TBA:

SNR vs AVDD1=AVDD2 L/ROUT1 (DAC path) for 16 $\Omega$ , 32 $\Omega$

SNR vs AVDD1=AVDD2 L/ROUT2 (DAC path) for 16 $\Omega$ , 32 $\Omega$

### THD+N Graphs TBA:

THD+N vs output power (Analogue in to L/ROUT1) 16 $\Omega$ , 32 $\Omega$

Plots for AVDD1=AVDD2=2.7, 3.0, 3.3, 3.6V

THD+N vs output power (Analogue in to L/ROUT2) 16 $\Omega$ , 32 $\Omega$

Plots for AVDD1=AVDD2=2.7, 3.0, 3.3, 3.6V

### PSRR Graphs TBA:

AVDD1 PSRR vs Frequency (DAC to L/ROUT1), 16 $\Omega$

AVDD1 PSRR vs Frequency (DAC to L/ROUT2), 16 $\Omega$

AVDD2 PSRR vs Frequency (DAC to L/ROUT2), 16 $\Omega$

## POWER CONSUMPTION

### TYPICAL SCENARIOS

Estimated current consumption for typical scenarios are shown below.

All measurements are made with quiescent signal.

Power delivered to the load is not included.

Control Register	Clocking Scheme (Unless otherwise specified)	Load	register settings (Hex values)	DCVDD (V)	DCVDD (mA)	DBVDD (V)	DBVDD (mA)	AVDD1 (V)	AVDD1 (mA)	AVDD2 (V)	AVDD2 (mA)	Total Power (mW)
Operational Mode	Slave Mode MCLK = 12.288MHz LFC = 48KHz BCLK = 3.048MHz	Ω										
OFF	No clocks	None	All default	3.3 2.5 1.8	0.001 0 0	3.3 2.5 1.8	0 0 0	3.3 2.5 2.5	0.01 0.008 0.008	3.3 2.5 3.3	0 0 0	0.036 0.020 0.020
Standby	No clocks	None	R1= 009, R49 = 006	3.3 2.5 1.8	0.001 0 0	3.3 2.5 1.8	0 0 0	3.3 2.5 2.5	0.145 0.115 0.115	3.3 2.5 2.5	0 0 0	0.482 0.288 0.288
L/ROUT1	Clocks on	None	R1=009, R2=180, R3=06F, R4=050, R6=000, R32=001, R33=001	3.3 2.5 1.8	6.8 4.8 3.2	3.3 2.5 1.8	0.008 0.005 0.003	3.3 2.5 2.5	5.8 4.3 4.3	3.3 2.5 2.5	0.7 0.5 0.5	43.916 24.013 17.765
L/ROUT2	Clocks on	None	R1=009, R3=06F, R4=050, R11=024, R17=004, R6=000, R32=001, R33=001	3.3 2.5 1.8	6.8 4.8 3.2	3.3 2.5 1.8	0.008 0.005 0.003	3.3 2.5 2.5	5.1 3.8 3.8	3.3 2.5 2.5	0.7 0.5 0.5	41.606 22.763 16.515
OUT3/OUT4 Stereo line out	Clocks on	None	R1=1FF, R3=1EF, R4=050, R6=000, R38=001, R39=001	3.3 2.5 1.8	6.88 4.82 3.2	3.3 2.5 1.8	0.008 0.005 0.003	3.3 2.5 2.5	5.1 3.8 3.8	3.3 2.5 2.5	0.7 0.5 0.5	41.870 22.813 16.515
ADC Stereo Record (psuedo MIC)	Clocks on	N/A	R1=0CD, R2=1BF, R4=050, R6=000, R2C=033, R2D=110, R2F=000, R2E=110, R30=000	3.3 2.5 1.8	7.3 5.1 3.45	3.3 2.5 1.8	0.04 0.03 0.02	3.3 2.5 2.5	8.1 6.5 6.5	3.3 2.5 2.5	0 0 0	50.952 29.075 22.496
ADC Stereo Record (line in)	Clocks on	N/A	R1=0CD, R2=1BF, R4=050, R6=000, R2F=050, R30=050	3.3 2.5 1.8	7.5 5.2 3.55	3.3 2.5 1.8	0.04 0.03 0.02	3.3 2.5 2.5	7.6 6.05 6.05	3.3 2.5 2.5	0 0 0	49.962 28.200 21.551
L/ROUT1 Master mode	Master mode / MCLK=13MHz	None	R1=029, R2=180, R3=00F, R4=050, R6=149, R32=001, R33=001, R24=007, R25=023, R26=1EA, R27=126	3.3 2.5 1.8	3.06 2.18 3.7	3.3 2.5 1.6	7.9 3.5 1.6	3.3 2.5 2.5	7.1 5.24 5.24	3.3 2.5 2.5	0 0 0	59.598 27.300 22.640
BYPASS to OUT3/OUT4	No clocks	None	R1=0CD, R2=03C, R3=180, R2F=050, R38=004, R30=050, R39=004	3.3 2.5 1.8	0.001 0 0	3.3 2.5 1.8	0.001 0 0	3.3 2.5 2.5	2.15 1.54 1.54	3.3 2.5 2.5	0 0 0	7.102 3.850 3.850

# AUDIO PATHS OVERVIEW

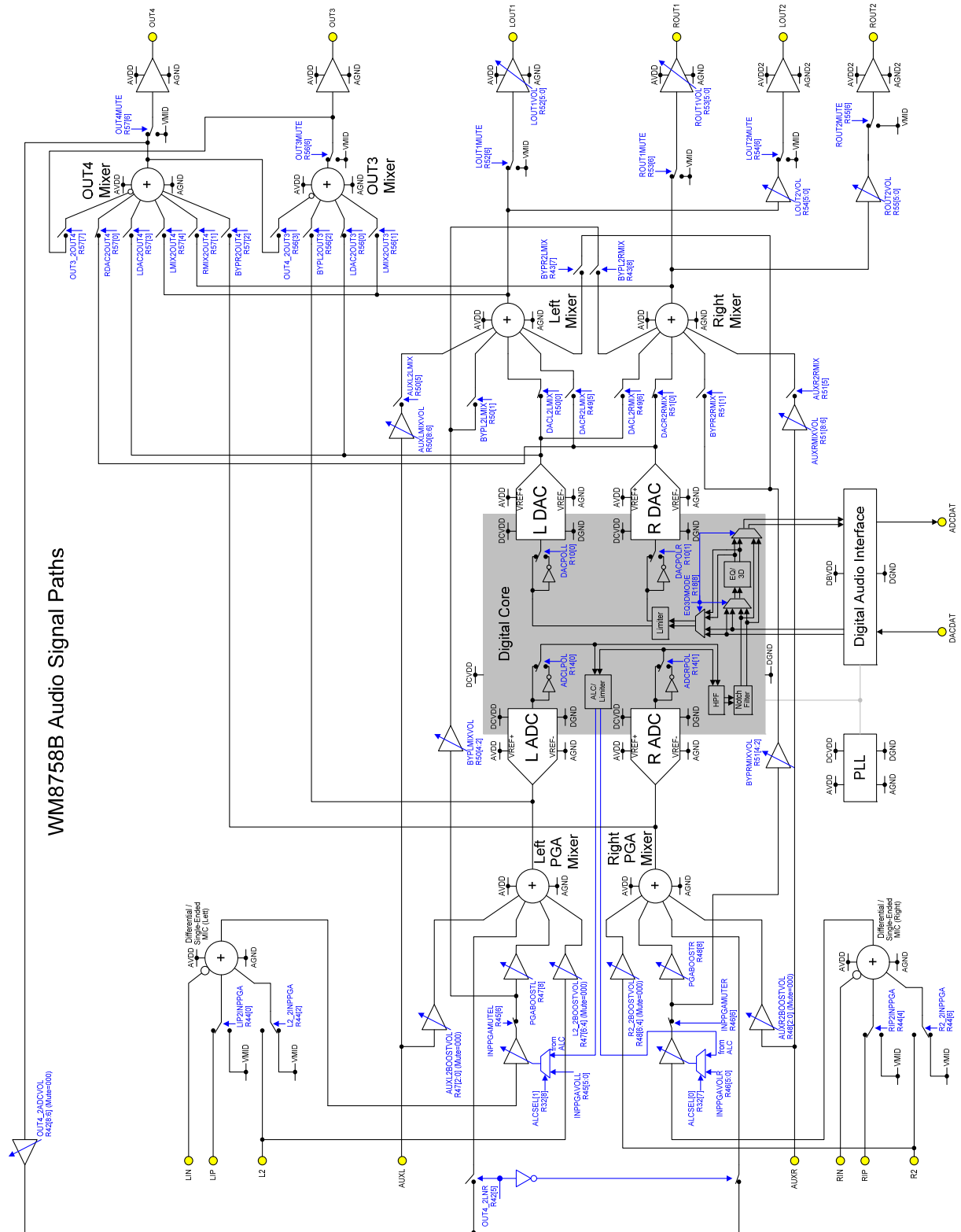


Figure 1 Audio Paths Overview

## SIGNAL TIMING REQUIREMENTS

### SYSTEM CLOCK TIMING

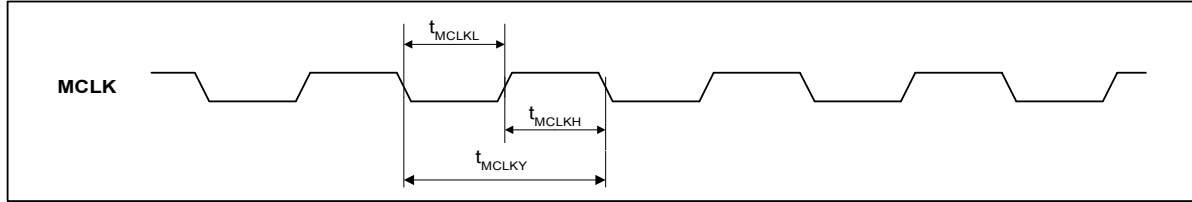


Figure 2 System Clock Timing Requirements

**Test Conditions**

DCVDD=1.8V, DBVDD=3.3V, AVDD1=AVDD2=3.0V, DGND=AGND1=AGND2=0V,  $T_A = +25^\circ\text{C}$ , Slave Mode

PARAMETER	SYMBOL	CONDITIONS	MIN	TYP	MAX	UNIT
<b>System Clock Timing Information</b>						
MCLK cycle time	$T_{MCLKY}$	MCLK=SYSCLK (=256fs)	81.38			ns
		MCLK input to PLL <sup>Note 1</sup>	20			ns
MCLK duty cycle	$T_{MCLKDS}$		60:40		40:60	

**Note:**

1. PLL pre-scaling and PLL N and K values should be set appropriately so that SYSCLK is no greater than 12.288MHz.

### AUDIO INTERFACE TIMING – MASTER MODE

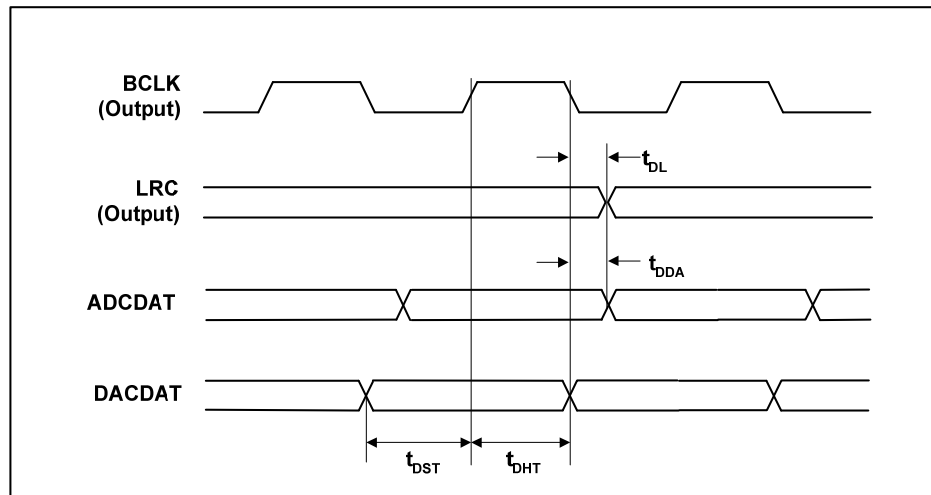


Figure 3 Digital Audio Data Timing – Master Mode (see Control Interface)



**Test Conditions**

DCVDD=1.8V, DBVDD=3.3V, AVDD1=AVDD2=3.0V, DGND=AGND1=AGND2=0V,  $T_A=+25^{\circ}\text{C}$ , Master Mode,  $f_s=48\text{kHz}$ , MCLK=256fs, 24-bit data, unless otherwise stated.

PARAMETER	SYMBOL	MIN	TYP	MAX	UNIT
<b>Audio Data Input Timing Information</b>					
LRC propagation delay from BCLK falling edge	$t_{DL}$			10	ns
ADCDAT propagation delay from BCLK falling edge	$t_{DDA}$			10	ns
DACDAT setup time to BCLK rising edge	$t_{DST}$	10			ns
DACDAT hold time from BCLK rising edge	$t_{DHT}$	10			ns

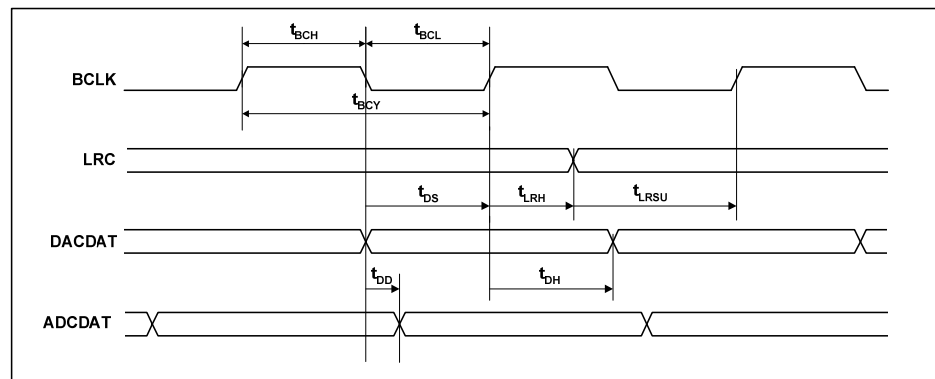
**AUDIO INTERFACE TIMING – SLAVE MODE**

Figure 4 Digital Audio Data Timing – Slave Mode

**Test Conditions**

DCVDD=1.8V, DBVDD=3.3V, AVDD1=AVDD2=3.0V, DGND=AGND1=AGND2=0V,  $T_A=+25^{\circ}\text{C}$ , Slave Mode,  $f_s=48\text{kHz}$ , MCLK= 256fs, 24-bit data, unless otherwise stated.

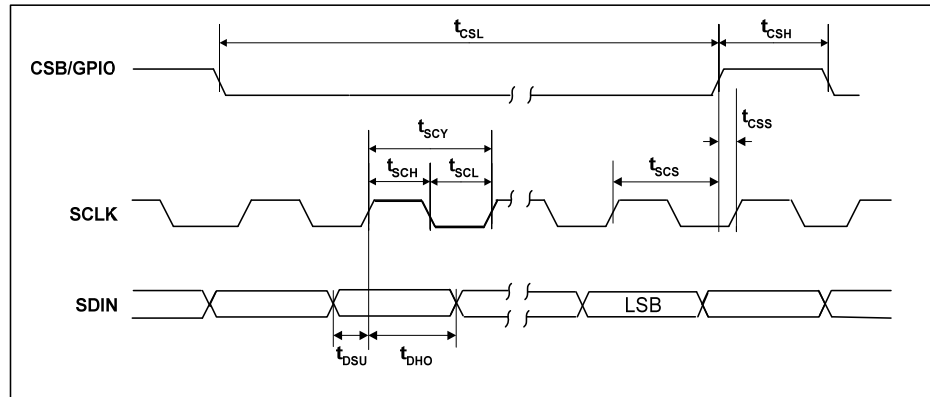
PARAMETER	SYMBOL	MIN	TYP	MAX	UNIT
<b>Audio Data Input Timing Information</b>					
BCLK cycle time	$t_{BCY}$	50			ns
BCLK pulse width high	$t_{BCH}$	20			ns
BCLK pulse width low	$t_{BCL}$	20			ns
LRC set-up time to BCLK rising edge	$t_{LRSU}$	10			ns
LRC hold time from BCLK rising edge	$t_{LRH}$	10			ns
DACDAT hold time from BCLK rising edge	$t_{DH}$	10			ns
ADCDAT propagation delay from BCLK falling edge	$t_{DD}$			10	ns

**Note:**

BCLK period should always be greater than or equal to MCLK period.

**CONTROL INTERFACE TIMING – 3-WIRE MODE**

3-wire mode is selected by connecting the MODE pin high.



**Figure 5 Control Interface Timing – 3-Wire Serial Control Mode**

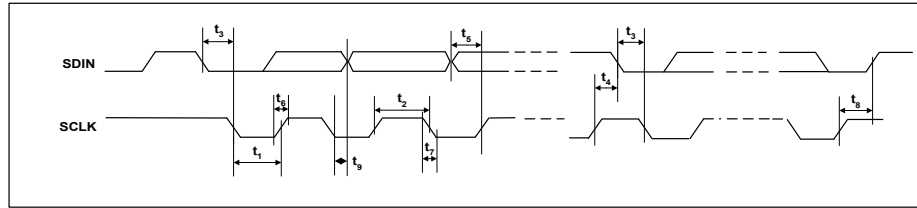
**Test Conditions**

DCVDD=1.8V, DBVDD=3.3V, AVDD1=AVDD2=3.0V, DGND = AGND1 = AGND2 = 0V,  $T_A=+25^{\circ}C$ , Slave Mode,  $f_s=48kHz$ , MCLK = 256fs, 24-bit data, unless otherwise stated.

PARAMETER	SYMBOL	MIN	TYP	MAX	UNIT
<b>Program Register Input Information</b>					
SCLK rising edge to CSB rising edge	$t_{SCS}$	80			ns
SCLK pulse cycle time	$t_{SCY}$	200			ns
SCLK pulse width low	$t_{SCL}$	80			ns
SCLK pulse width high	$t_{SCH}$	80			ns
SDIN to SCLK set-up time	$t_{DSU}$	40			ns
SCLK to SDIN hold time	$t_{DHO}$	40			ns
CSB pulse width low	$t_{CSL}$	40			ns
CSB pulse width high	$t_{CSH}$	40			ns
CSB rising to SCLK rising	$t_{CSS}$	40			ns
Pulse width of spikes that will be suppressed	$t_{ps}$	0		5	ns

**CONTROL INTERFACE TIMING – 2-WIRE MODE**

2-wire mode is selected by connecting the MODE pin low.



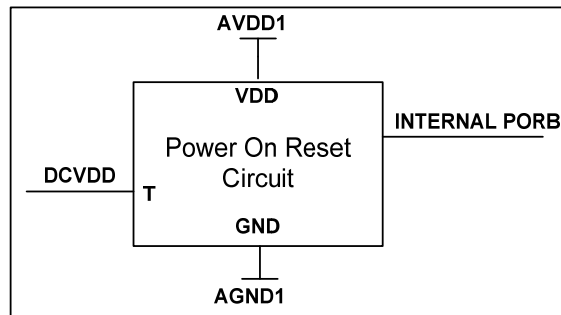
**Figure 6 Control Interface Timing – 2-Wire Serial Control Mode**

**Test Conditions**

DCVDD=1.8V, DBVDD=3.3V, AVDD1=AVDD2=3.0V, DGND=AGND1=AGND2=0V, TA=+25°C, Slave Mode, fs=48kHz, MCLK = 256fs, 24-bit data, unless otherwise stated.

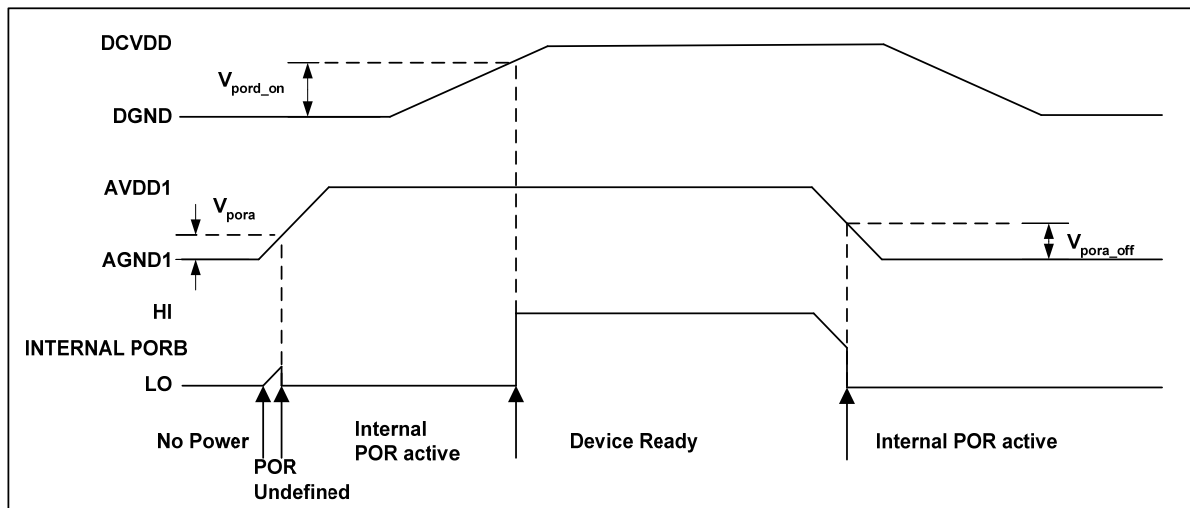
PARAMETER	SYMBOL	MIN	TYP	MAX	UNIT
<b>Program Register Input Information</b>					
SCLK Frequency		0		526	kHz
SCLK Low Pulse-Width	t <sub>1</sub>	1.3			us
SCLK High Pulse-Width	t <sub>2</sub>	600			ns
Hold Time (Start Condition)	t <sub>3</sub>	600			ns
Setup Time (Start Condition)	t <sub>4</sub>	600			ns
Data Setup Time	t <sub>5</sub>	100			ns
SDIN, SCLK Rise Time	t <sub>6</sub>			300	ns
SDIN, SCLK Fall Time	t <sub>7</sub>			300	ns
Setup Time (Stop Condition)	t <sub>8</sub>	600			ns
Data Hold Time	t <sub>9</sub>			900	ns
Pulse width of spikes that will be suppressed	t <sub>ps</sub>	0		5	ns

**INTERNAL POWER ON RESET CIRCUIT**



**Figure 7 Internal Power on Reset Circuit Schematic**

The WM8758B includes an internal Power-On-Reset Circuit, as shown in Figure 7, which is used to reset the digital logic into a default state after power up. The POR circuit is powered from AVDD1 and monitors DCVDD. It asserts PORB low if AVDD1 or DCVDD is below a minimum threshold.



**Figure 8 Typical Power up Sequence where AVDD1 is Powered before DCVDD**

Figure 8 shows a typical power-up sequence where AVDD1 comes up first. When AVDD1 goes above the minimum threshold,  $V_{pora}$ , there is enough voltage for the circuit to guarantee PORB is asserted low and the chip is held in reset. In this condition, all writes to the control interface are ignored. Now AVDD1 is at full supply level. Next DCVDD rises to  $V_{pord\_on}$  and PORB is released high and all registers are in their default state and writes to the control interface may take place.

On power down, where AVDD1 falls first, PORB is asserted low whenever AVDD1 drops below the minimum threshold  $V_{pora\_off}$ .

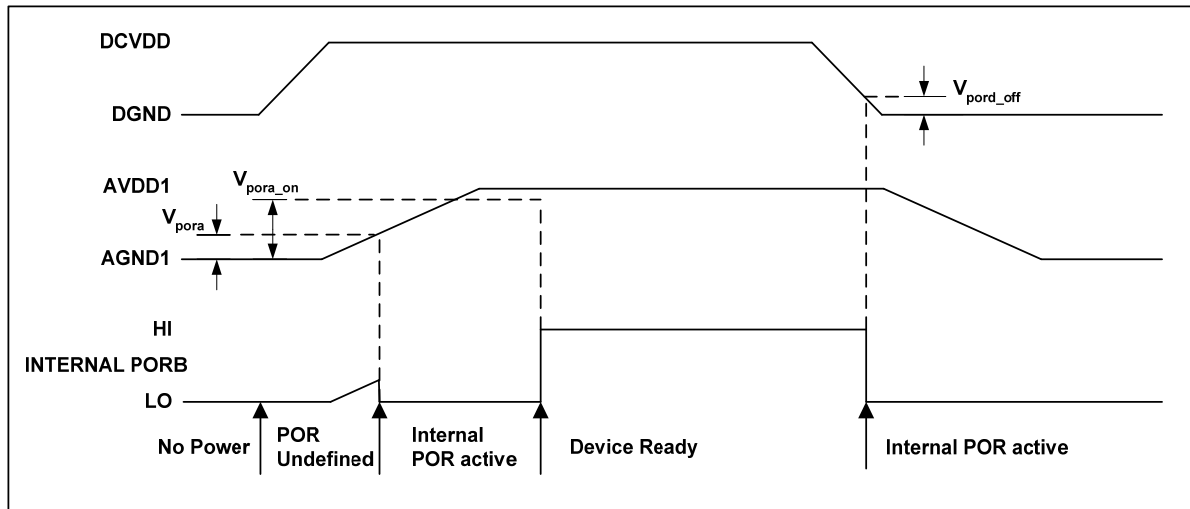


Figure 9 Typical Power up Sequence where DCVDD is Powered before AVDD1

Figure 9 shows a typical power-up sequence where DCVDD comes up first. First it is assumed that DCVDD is already up to specified operating voltage. When AVDD1 goes above the minimum threshold,  $V_{pora}$ , there is enough voltage for the circuit to guarantee PORB is asserted low and the chip is held in reset. In this condition, all writes to the control interface are ignored. When AVDD1 rises to  $V_{pora\_on}$ , PORB is released high and all registers are in their default state and writes to the control interface may take place.

On power down, where DCVDD falls first, PORB is asserted low whenever DCVDD drops below the minimum threshold  $V_{pord\_off}$ .

SYMBOL	MIN	TYP	MAX	UNIT
$V_{pora}$	0.4	0.6	0.8	V
$V_{pora\_on}$	0.9	1.2	1.6	V
$V_{pora\_off}$	0.4	0.6	0.8	V
$V_{pord\_on}$	0.5	0.7	0.9	V
$V_{pord\_off}$	0.4	0.6	0.8	V

Table 1 Typical POR Operation (typical values, not tested)

**Notes:**

If AVDD1 and DCVDD suffer a brown-out (i.e. drop below the minimum recommended operating level but do not go below  $V_{pora\_off}$  or  $V_{pord\_off}$ ) then the chip will not reset and will resume normal operation when the voltage is back to the recommended level again.

The chip will enter reset at power down when AVDD1 or DCVDD falls below  $V_{pora\_off}$  or  $V_{pord\_off}$ . This may be important if the supply is turned on and off frequently by a power management system.

The minimum  $t_{por}$  period is maintained even if DCVDD and AVDD1 have zero rise time. This specification is guaranteed by design rather than test.

## RECOMMENDED POWER UP/DOWN SEQUENCE

In order to minimise output pop and click noise, it is recommended that the WM8758B device is powered up and down under control using the following sequences:

### Power Up:

1. Turn on external power supplies. Wait for supply voltage to settle.
2. Set low bias mode, BIASCUT = 1.
3. Enable HPCOM = 1, LINECOM = 1.
4. Mute all Outputs and set PGAs to minimum gain, R52 to R57 = 0x140h.
5. Enable L/ROUT1
6. Enable L/ROUT2
7. Enable VMID independent current bias, POBCTRL = 1.
8. Enable required DACs and mixers.
9. Enable VMIDSEL=01, BIASEN = 1 and BUFIOEN = 1
10. Setup digital interface, input amplifiers, PLL, ADCs and DACs for desired operation.
11. Wait 100ms to allow VMID to rise sufficiently before unmuting outputs
12. Unmute L/ROUT1 and set desired volume, e.g. for 0dB R52 and R53 = 0x139h.
13. Unmute L/ROUT2 and set desired volume, e.g. for 0dB R54 and R55 = 0x139h.
14. Disable VMID independent current bias, POBCTRL = 0.

### Power Down:

1. Disable Thermal shutdown
2. Enable VMIDTOG = 1
3. Disable VMIDSEL=00 and BUFIOEN=0
4. Wait for VMID to discharge
5. Power off registers R1, R2, R3 = 0x000h
6. Remove external power supplies

### Notes:

1. Charging time constant is determined by impedance selected by VMIDSEL and the value of decoupling capacitor connected to VMID pin.
2. It is possible to interrupt the power down sequence and power up to VMID before the allocated VMID discharge time.

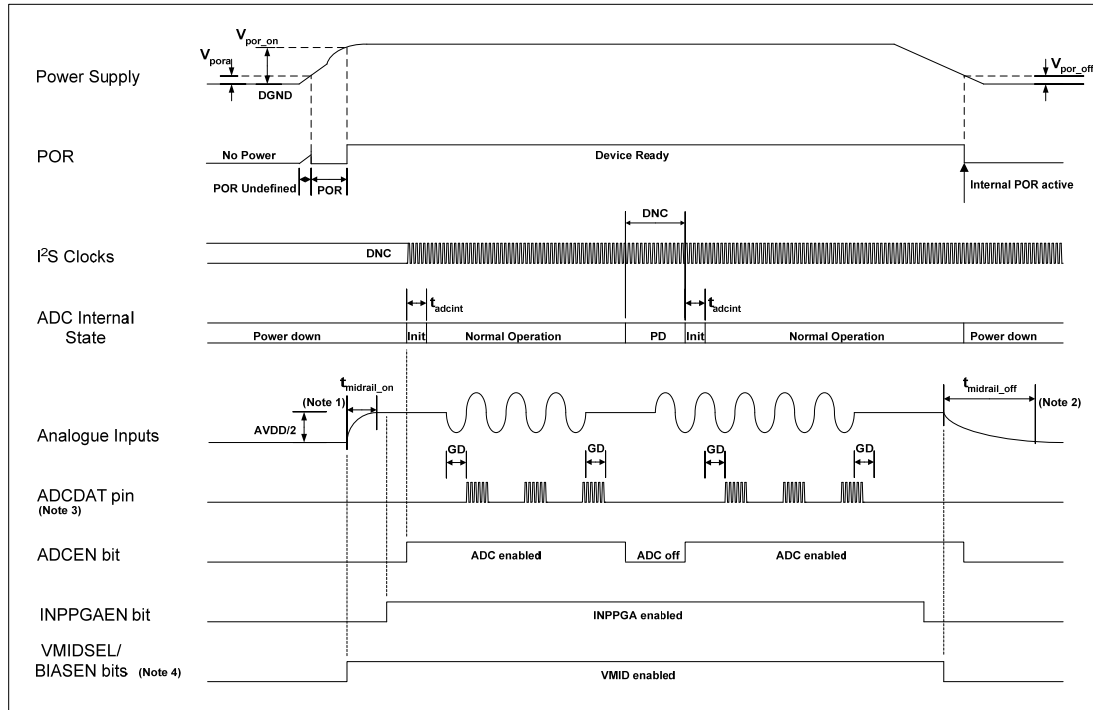


Figure 10 ADC Power Up and Down Sequence (not to scale)

SYMBOL	MIN	TYPICAL	MAX	UNIT
$t_{midrail\_on}$		300		ms
$t_{midrail\_off}$		>6		s
$t_{adcint}$		2/fs		n/fs
ADC Group Delay		29/fs		n/fs

Table 2 Typical POR Operation (typical values, not tested)

Notes:

1. The analogue input pin charge time,  $t_{midrail\_on}$ , is determined by the VMID pin charge time. This time is dependent upon the value of VMID decoupling capacitor and VMID pin input resistance and AVDD power supply rise time.
2. The analogue input pin discharge time,  $t_{midrail\_off}$ , is determined by the analogue input coupling capacitor discharge time. The time,  $t_{midrail\_off}$ , is measured using a 1µF capacitor on the analogue input but will vary dependent upon the value of input coupling capacitor.
3. While the ADC is enabled there will be LSB data bit activity on the ADCDAT pin due to system noise but no significant digital output will be present.
4. The VMIDSEL and BIASEN bits must be set to enable analogue input midrail voltage and for normal ADC operation.
5. ADCDAT data output delay from power up - with power supplies starting from 0V - is determined primarily by the VMID charge time. ADC initialisation and power management bits may be set immediately after POR is released; VMID charge time will be significantly longer and will dictate when the device is stabilised for analogue input.
6. ADCDAT data output delay at power up from device standby (power supplies already applied) is determined by ADC initialisation time, 2/fs.

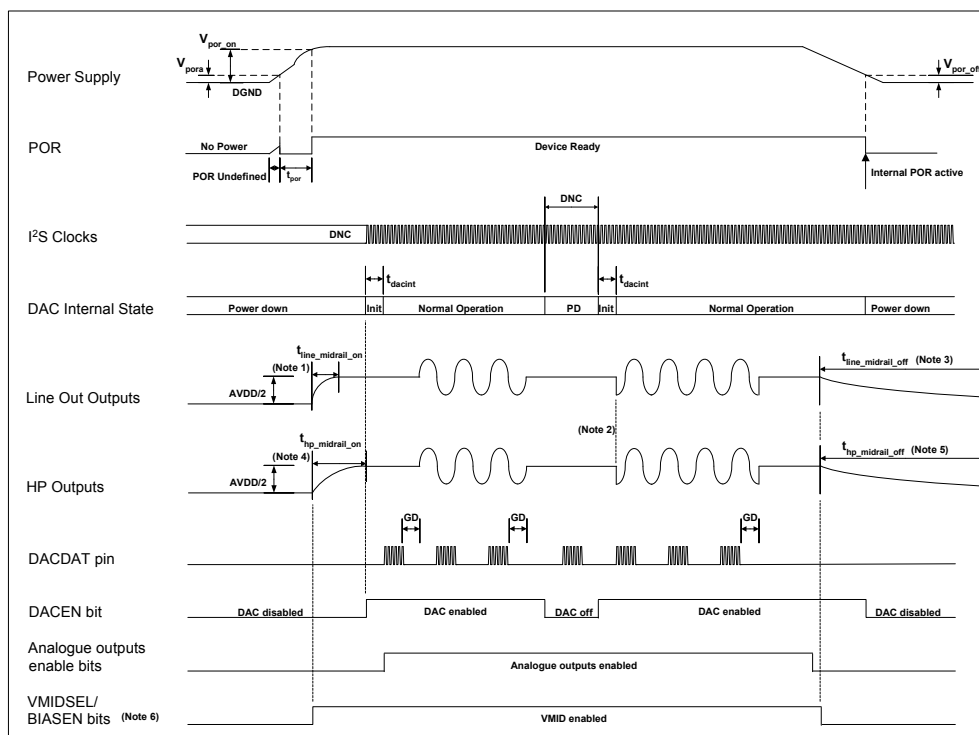


Figure 11 DAC Power Up and Down Sequence (not to scale)

SYMBOL	MIN	TYPICAL	MAX	UNIT
t <sub>line_midrail_on</sub>		300		ms
t <sub>line_midrail_off</sub>		>6		s
t <sub>hp_midrail_on</sub>		300		ms
t <sub>hp_midrail_off</sub>		>6		s
t <sub>dacint</sub>		2/fs		n/fs
DAC Group Delay		29/fs		n/fs

Table 3 Typical POR Operation (typical values, not tested)

Notes:

1. The lineout charge time, t<sub>line\_midrail\_on</sub>, is determined by the VMID pin charge time. This time is dependent upon the value of VMID decoupling capacitor and VMID pin input resistance and AVDD power supply rise time. The values above were measured using a 4.7µF capacitor.
2. It is not advisable to allow DACDAT data input during initialisation of the DAC. If the DAC data value is not zero at point of initialisation, then this is likely to cause a pop noise on the analogue outputs. The same is also true if the DACDAT is removed at a non-zero value, and no mute function has been applied to the signal beforehand.
3. The lineout discharge time, t<sub>line\_midrail\_off</sub>, is determined by the VMID pin discharge time. This time is dependent upon the value of VMID decoupling capacitor and VMID pin input resistance. The values above were measured using a 4.7µF capacitor.
4. The headphone charge time, t<sub>hp\_midrail\_on</sub>, is dependent upon the value of VMID decoupling capacitor and VMID pin input resistance and AVDD power supply rise time. The values above were measured using a 4.7µF VMID decoupling capacitor.
5. The headphone discharge time, t<sub>hp\_midrail\_off</sub>, is dependent upon the value of VMID decoupling capacitor and VMID pin input resistance. The values above were measured using a 4.7µF VMID decoupling capacitor.
6. The VMIDSEL and BIASEN bits must be set to enable analogue output midrail voltage and for normal DAC operation.



## DEVICE DESCRIPTION

### INTRODUCTION

The WM8758B is a low power audio codec combining a high quality stereo audio DAC and ADC, with flexible line and microphone input and output processing.

#### FEATURES

The chip offers great flexibility in use, and so can support many different modes of operation as follows:

#### MICROPHONE INPUTS

Two pairs of stereo microphone inputs are provided, allowing a pair of stereo microphones to be pseudo-differentially connected, with user defined gain. The provision of the common mode input pin for each stereo input allows for rejection of common mode noise on the microphone inputs (level depends on gain setting chosen). A microphone bias is output from the chip which can be used to bias both microphones. The signal routing can be configured to allow manual adjustment of mic levels, or to allow the ALC loop to control the level of mic signal that is transmitted.

Total gain through the microphone paths of up to +55.25dB can be selected.

#### PGA AND ALC OPERATION

A programmable gain amplifier is provided in the input path to the ADC. This may be used manually or in conjunction with a mixed analogue/digital automatic level control (ALC) which keeps the recording volume constant.

#### ADC

The stereo ADC uses a 24-bit high-order oversampling architecture to deliver optimum performance with low power consumption.

#### HI-FI DAC

The hi-fi DAC provides high quality audio playback suitable for all portable audio hi-fi type applications, including MP3 players and portable disc players of all types.

#### OUTPUT MIXERS

Flexible mixing is provided on the outputs of the device. A stereo mixer is provided for the stereo headphone or line outputs, LOUT1/ROUT1, and additional summers on the OUT3/OUT4 outputs allow for an optional differential or stereo line output on these pins. Gain adjustment PGAs are provided for the LOUT1/ROUT1 and LOUT2/ROUT2 outputs, and signal switching is provided to allow for all possible signal combinations.

OUT3 and OUT4 can be configured to provide an additional stereo or mono differential lineout from the output of the DACs, the mixers or the input microphone boost stages. They can also provide a midrail reference for pseudo differential inputs to external amplifiers. OUT3 and OUT4 should not be used as a buffered midrail reference in capless mode.

#### AUDIO INTERFACES

The WM8758B has a standard audio interface, to support the transmission of stereo data to and from the chip. This interface is a 3 wire standard audio interface which supports a number of audio data formats including:

- I<sup>2</sup>S
- DSP/PCM Mode (a burst mode in which LRC sync plus 2 data packed words are transmitted)
- MSB-First, left justified
- MSB-First, right justified

The interface can operate in master or slave modes.

#### CONTROL INTERFACES

To allow full software control over all features, the WM8758B offers a choice of 2 or 3 wire control interface. It is fully compatible and an ideal partner for a wide range of industry standard microprocessors, controllers and DSPs.

Selection of the mode is via the MODE pin. In 2 wire mode, the address of the device is fixed as 0011010b.

**CLOCKING SCHEMES**

WM8758B offers the normal audio DAC clocking scheme operation, where 256fs MCLK is provided to the DAC and ADC. A PLL is included which may be used to generate these clocks in the event that they are not available from the system controller. This PLL can accept a range of common input clock frequencies between 8MHz and 50MHz to generate high quality audio clocks. If this PLL is not required for generation of these clocks, it can be reconfigured to generate alternative clocks which may then be output on the GPIO pins and used elsewhere in the system.

**POWER CONTROL**

The design of the WM8758B has given much attention to power consumption without compromising performance. It operates at very low voltages, includes the ability to power off any unused parts of the circuitry under software control, and includes standby and power off modes.

**INPUT SIGNAL PATH**

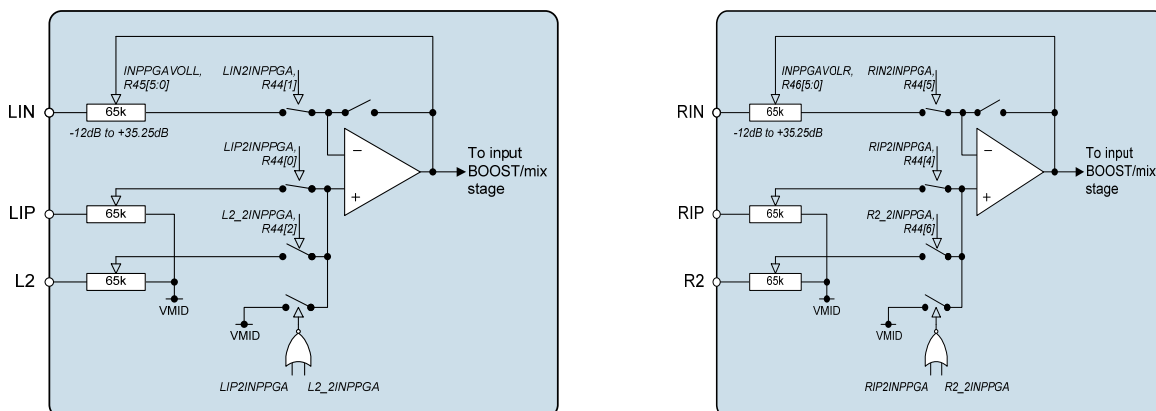
The WM8758B has a number of flexible analogue inputs. There are two input channels, Left and Right, each of which consists of an input PGA stage followed by a boost/mix stage which drives into the hi-fi ADC. Each input path has three input pins which can be configured in a variety of ways to accommodate single-ended, differential or dual differential microphones. A bypass path exists from the output of the boost/mix stage into the output left/right mixers.

**MICROPHONE INPUTS**

The WM8758B can accommodate a variety of microphone configurations including single ended and differential inputs. The inputs to the left differential input PGA are LIN, LIP and L2. The inputs to the right differential input PGA are RIN, RIP and R2.

In single-ended microphone input configuration the microphone signal should be input to LIN or RIN and the internal NOR gate configured to clamp the non-inverting input of the input PGA to VMID.

In differential mode the larger signal should be input to LIP or RIP and the smaller (e.g. noisy ground connection) should be input to LIN or RIN.



**Figure 12 Microphone Input PGA Circuit**

The input PGAs are enabled by the IPPGAENL/R register bits.

REGISTER ADDRESS	BIT	LABEL	DEFAULT	DESCRIPTION
R2 Power Management 2	2	INPPGAENL	0	Left channel input PGA enable 0 = disabled 1 = enabled
	3	INPPGAENR	0	Right channel input PGA enable 0 = disabled 1 = enabled

**Table 4 Input PGA Enable Register Settings**

REGISTER ADDRESS	BIT	LABEL	DEFAULT	DESCRIPTION
R44 Input Control	0	LIP2INPPGA	1	Connect LIP pin to left channel input PGA amplifier positive terminal. 0 = LIP not connected to input PGA 1 = input PGA amplifier positive terminal connected to LIP (constant input impedance)
	1	LIN2INPPGA	1	Connect LIN pin to left channel input PGA negative terminal. 0 = LIN not connected to input PGA 1 = LIN connected to input PGA amplifier negative terminal.
	2	L2_2INPPGA	0	Connect L2 pin to left channel input PGA positive terminal. 0 = L2 not connected to input PGA 1 = L2 connected to input PGA amplifier positive terminal (constant input impedance).
	4	RIP2INPPGA	1	Connect RIP pin to right channel input PGA amplifier positive terminal. 0 = RIP not connected to input PGA 1 = right channel input PGA amplifier positive terminal connected to RIP (constant input impedance)
	5	RIN2INPPGA	1	Connect RIN pin to right channel input PGA negative terminal. 0 = RIN not connected to input PGA 1 = RIN connected to right channel input PGA amplifier negative terminal.
	6	R2_2INPPGA	0	Connect R2 pin to right channel input PGA positive terminal. 0 = R2 not connected to input PGA 1 = R2 connected to input PGA amplifier positive terminal (constant input impedance).

Table 5 Input PGA Control

### INPUT PGA VOLUME CONTROLS

The input microphone PGAs have a gain range from -12dB to +35.25dB in 0.75dB steps. The gain from the LIN/RIN input to the PGA output and from the L2/R2 amplifier to the PGA output are always common and controlled by the register bits INPPGAVOLL/R[5:0]. These register bits also affect the LIP pin when LIP2INPPGA=1, the L2 pin when L2\_2INPPGA=1, the RIP pin when RIP2INPPGA=1 and the R2 pin when R2\_2INPPGA=1.

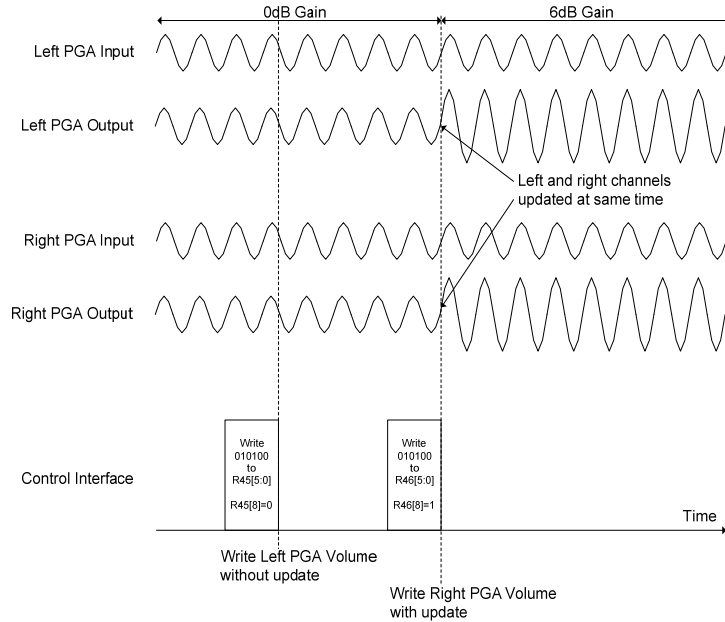
When the Automatic Level Control (ALC) is enabled the input PGA gains are controlled automatically and the INPPGAVOLL/R bits should not be used.

REGISTER ADDRESS	BIT	LABEL	DEFAULT	DESCRIPTION
R45 Left channel input PGA volume control	5:0	INPPGAVOLL	010000	Left channel input PGA volume 000000 = -12dB 000001 = -11.25db . 010000 = 0dB . 111111 = +35.25dB
	6	INPPGAMUTEL	0	Mute control for left channel input PGA: 0 = Input PGA not muted, normal operation 1 = Input PGA muted (and disconnected from the following input BOOST stage).
	7	INPPGAZCL	0	Left channel input PGA zero cross enable: 0 = Update gain when gain register changes 1 = Update gain on 1 <sup>st</sup> zero cross after gain register write.
	8	INPPGAVU	Not latched	INPPGA left and INPPGA right volume do not update until a 1 is written to INPPGAVU (in reg 45 or 46) (See "Volume Updates" below)
R46 Right channel input PGA volume control	5:0	INPPGAVOLR	010000	Right channel input PGA volume 000000 = -12dB 000001 = -11.25db . 010000 = 0dB . 111111 = +35.25dB
	6	INPPGAMUTER	0	Mute control for right channel input PGA: 0 = Input PGA not muted, normal operation 1 = Input PGA muted (and disconnected from the following input BOOST stage).
	7	INPPGAZCR	0	Right channel input PGA zero cross enable: 0 = Update gain when gain register changes 1 = Update gain on 1 <sup>st</sup> zero cross after gain register write.
	8	INPPGAVU	Not latched	INPPGA left and INPPGA right volume do not update until a 1 is written to INPPGAVU (in reg 45 or 46) (See "Volume Updates" below)
R32 ALC control 1	8:7	ALCSEL	00	ALC function select: 00 = ALC off 01 = ALC right only 10 = ALC left only 11 = ALC both on

Table 6 Input PGA Volume Control

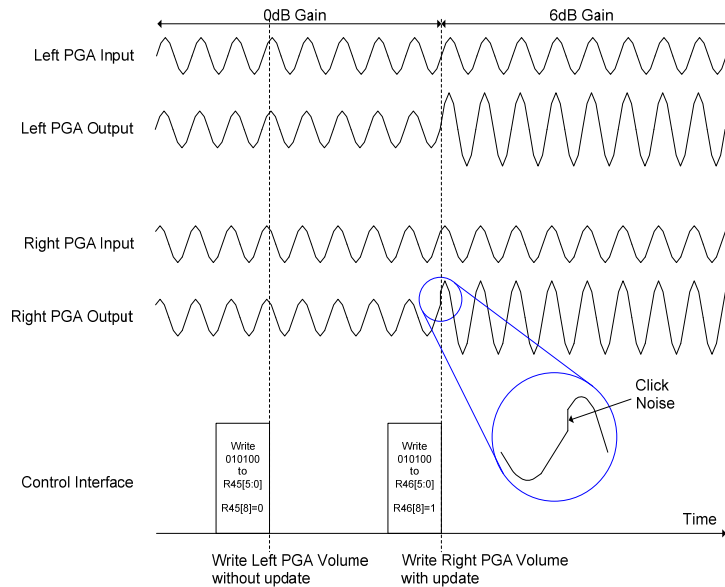
**VOLUME UPDATES**

Volume settings will not be applied to the PGAs until a '1' is written to one of the INPPGAVU bits. This is to allow left and right channels to be updated at the same time, as shown in Figure 13.



**Figure 13 Simultaneous Left and Right Volume Updates**

If the volume is adjusted while the signal is a non-zero value, an audible click can occur as shown in Figure 14.



**Figure 14 Click Noise during Volume Update**

In order to prevent this click noise, a zero cross function is provided. When enabled, this will cause the PGA volume to update only when a zero crossing occurs, equalizer click noise as shown in Figure 15.

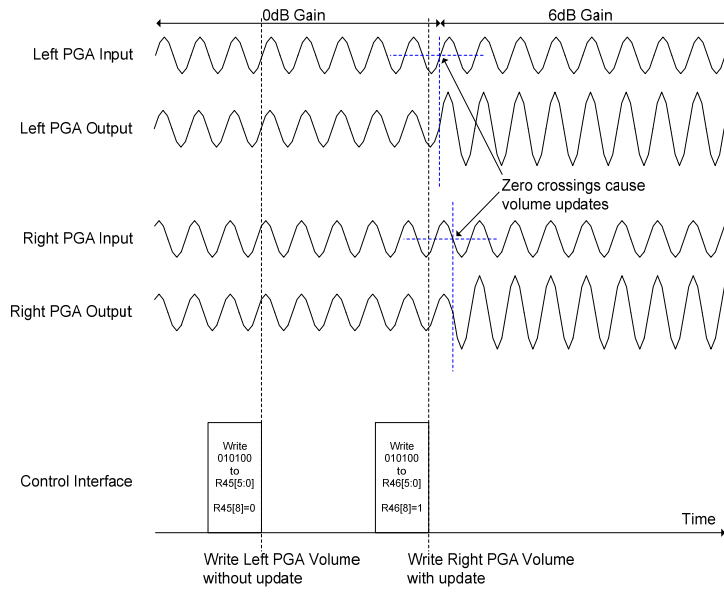


Figure 15 Volume Update using Zero Cross Detection

If there is a long period where no zero-crossing occurs, a timeout circuit in the WM8758B will automatically update the volume. The volume updates will occur between one and two timeout periods, depending on when the INPPGAVU bit is set as shown in Figure 16.

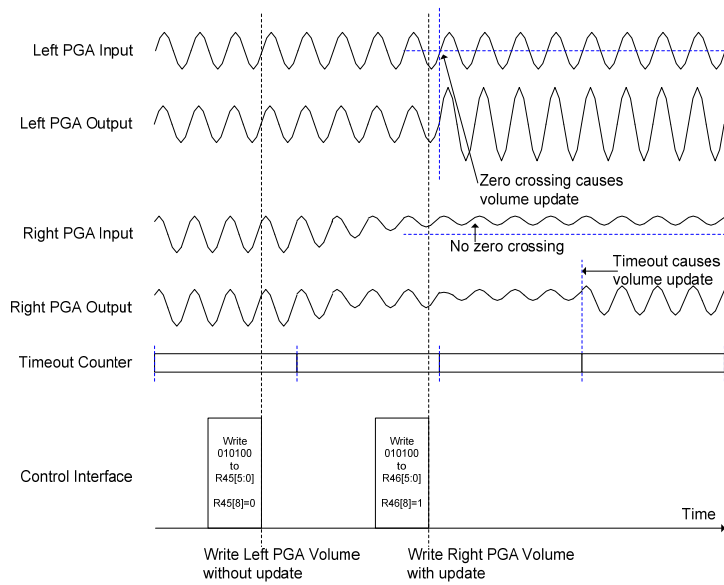


Figure 16 Volume Update after Timeout

**INPUT BOOST**

Each of the stereo input PGA stages is followed by an input BOOST circuit. The input BOOST circuit has 3 selectable inputs: the input microphone PGA output, the L2/R2 input pin (can be used as a line input, bypassing the input PGA), and OUT4 mixer output. These three inputs can be mixed together and have individual gain boost/adjust as shown in Figure 17.

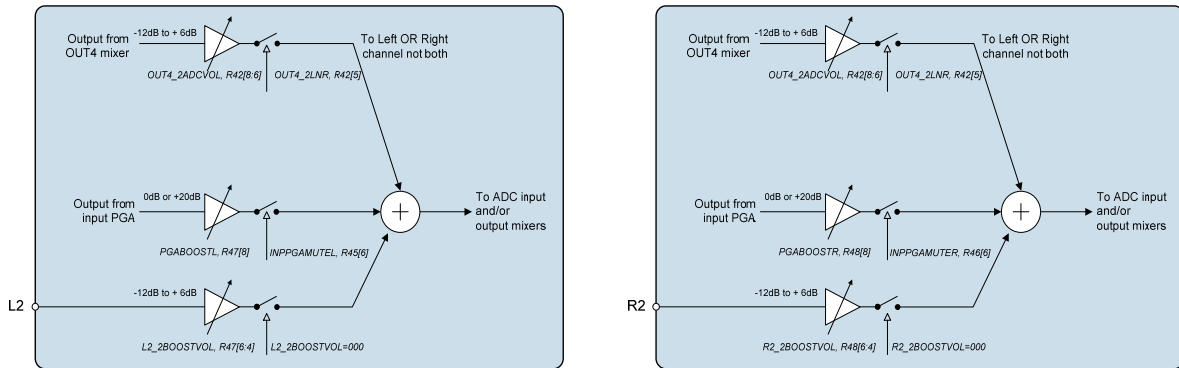


Figure 17 Input Boost Stage

The input PGA paths can have a +20dB boost (PGABOOSTL/R=1), a 0dB pass through (PGABOOSTL/R=0) or be completely isolated from the input boost circuit (INPPGAMUTEL/R=1).

REGISTER ADDRESS	BIT	LABEL	DEFAULT	DESCRIPTION
R47 Left Input BOOST control	8	PGABOOSTL	1	Boost enable for left channel input PGA: 0 = PGA output has +0dB gain through input BOOST stage. 1 = PGA output has +20dB gain through input BOOST stage.
R48 Right Input BOOST control	8	PGABOOSTR	1	Boost enable for right channel input PGA: 0 = PGA output has +0dB gain through input BOOST stage. 1 = PGA output has +20dB gain through input BOOST stage.

Table 7 Input BOOST Stage Control

REGISTER ADDRESS	BIT	LABEL	DEFAULT	DESCRIPTION
R42 OUT4 to ADC	8:6	OUT4_2ADCVOL	000	Controls the OUT4 to ADC input boost stage: 000 = Path disabled (disconnected) 001 = -12dB gain through boost stage 010 = -9dB gain through boost stage ... 111 = +6dB gain through boost stage
	5	OUT4_2LNR	0	OUT4 to L or R ADC input 0 = Right ADC input 1 = Left ADC input
R47 Left channel Input BOOST control	6:4	L2_2BOOSTVOL	000	Controls the L2 pin to the left channel input boost stage: 000 = Path disabled (disconnected) 001 = -12dB gain through boost stage 010 = -9dB gain through boost stage ... 111 = +6dB gain through boost stage
R48 Right channel Input BOOST control	6:4	R2_2BOOSTVOL	000	Controls the R2 pin to the right channel input boost stage: 000 = Path disabled (disconnected) 001 = -12dB gain through boost stage 010 = -9dB gain through boost stage ... 111 = +6dB gain through boost stage

Table 8 Input BOOST Stage Control

The BOOST stage is enabled under control of the BOOSTEN register bit.

REGISTER ADDRESS	BIT	LABEL	DEFAULT	DESCRIPTION
R2 Power management 2	4	BOOSTENL	0	Left channel Input BOOST enable 0 = Boost stage OFF 1 = Boost stage ON
	5	BOOSTENR	0	Right channel Input BOOST enable 0 = Boost stage OFF 1 = Boost stage ON

Table 9 Input BOOST Enable Control



### MICROPHONE BIASING CIRCUIT

The MICBIAS output provides a low noise reference voltage suitable for biasing electret type microphones and the associated external resistor biasing network. Refer to the Applications Information section for recommended external components. The MICBIAS voltage can be altered via the MBVSEL register bit. When MBVSEL=0, MICBIAS=0.9\*AVDD1 and when MBVSEL=1, MICBIAS=0.65\*AVDD1. The output can be enabled or disabled using the MICBEN control bit.

REGISTER ADDRESS	BIT	LABEL	DEFAULT	DESCRIPTION
R1 Power management 1	4	MICBEN	0	Microphone Bias Enable 0 = OFF (high impedance output) 1 = ON

Table 10 Microphone Bias Enable Control

REGISTER ADDRESS	BIT	LABEL	DEFAULT	DESCRIPTION
R44 Input control	8	MBVSEL	0	Microphone Bias Voltage Control 0 = 0.9 * AVDD1 1 = 0.65 * AVDD1

Table 11 Microphone Bias Voltage Control

The internal MICBIAS circuitry is shown in Figure 18. Note that the maximum source current capability for MICBIAS is 3mA. The external biasing resistors therefore must be large enough to limit the MICBIAS current to 3mA.

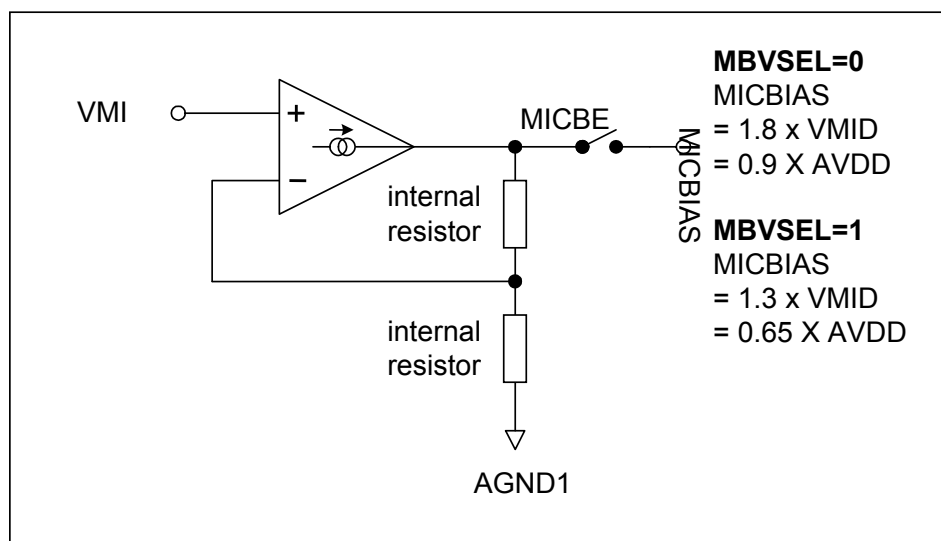


Figure 18 Microphone Bias Schematic

## ANALOGUE TO DIGITAL CONVERTER (ADC)

The WM8758B uses stereo multi-bit, oversampled sigma-delta ADCs. The use of multi-bit feedback and high oversampling rates reduces the effects of jitter and high frequency noise. The ADC Full Scale input level is proportional to AVDD1. With a 3.3V supply voltage, the full scale level is 1.0V<sub>rms</sub>. Any voltage greater than full scale may overload the ADC and cause distortion.

### ADC DIGITAL FILTERS

The ADC filters perform true 24 bit signal processing to convert the raw multi-bit oversampled data from the ADC to the correct sampling frequency to be output on the digital audio interface. The digital filter path for each ADC channel is illustrated in Figure 19.

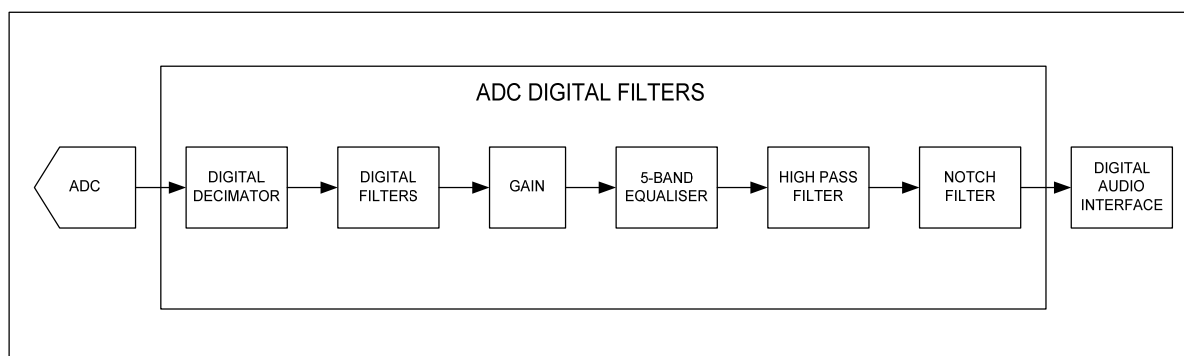


Figure 19 ADC Digital Filter Path

The ADCs are enabled by the ADCENL/R register bit.

REGISTER ADDRESS	BIT	LABEL	DEFAULT	DESCRIPTION
R2 Power management 2	0	ADCENL	0	Enable ADC left channel: 0 = ADC disabled 1 = ADC enabled
	1	ADCENR	0	Enable ADC right channel: 0 = ADC disabled 1 = ADC enabled

Table 12 ADC Enable Control

The polarity of the output signal can also be changed under software control using the ADCLPOL/ADCRPOL register bit. The oversampling rate of the ADC can be adjusted using the ADCOSR register bit. With ADCOSR=0 the oversample rate is 64x which gives lowest power operation and when ADCOSR=1 the oversample rate is 128x which gives best performance.

REGISTER ADDRESS	BIT	LABEL	DEFAULT	DESCRIPTION
R14 ADC Control	0	ADCLPOL	0	ADC left channel polarity adjust: 0 = normal 1 = inverted
	1	ADCRPOL	0	ADC right channel polarity adjust: 0 = normal 1 = inverted
	3	ADCOSR	0	ADC oversample rate select: 0 = 64x (lower power) 1 = 128x (best performance)

Table 13 ADC Control

### SELECTABLE HIGH PASS FILTER

A selectable high pass filter is provided. To disable this filter set HPFEN=0. The filter has two modes controlled by HPFAPP. In Audio Mode (HPFAPP=0) the filter is first order, with a cut-off frequency of 3.7Hz. In Application Mode (HPFAPP=1) the filter is second order, with a cut-off frequency selectable via the HPFCUT register. The cut-off frequencies when HPFAPP=1 are shown in Table 15.

REGISTER ADDRESS	BIT	LABEL	DEFAULT	DESCRIPTION
R14 ADC Control	8	HPFEN	1	High Pass Filter Enable 0 = disabled 1 = enabled
	7	HPFAPP	0	Select audio mode or application mode 0 = Audio mode (1 <sup>st</sup> order, $f_c = \sim 3.7\text{Hz}$ ) 1 = Application mode (2 <sup>nd</sup> order, $f_c = \text{HPFCUT}$ )
	6:4	HPFCUT	000	Application mode cut-off frequency See Table 15 for details.

Table 14 ADC Enable Control

HPFCUT [2:0]	SR=101/100			SR=011/010			SR=001/000		
	fs (kHz)								
	8	11.025	12	16	22.05	24	32	44.1	48
000	82	113	122	82	113	122	82	113	122
001	102	141	153	102	141	153	102	141	153
010	131	180	156	131	180	156	131	180	156
011	163	225	245	163	225	245	163	225	245
100	204	281	306	204	281	306	204	281	306
101	261	360	392	261	360	392	261	360	392
110	327	450	490	327	450	490	327	450	490
111	408	563	612	408	563	612	408	563	612

Table 15 High Pass Filter Cut-off Frequencies (HPFAPP=1)

Note that the High Pass filter values (when HPFAPP=1) are calculated on the assumption that the SR register bits are set correctly for the actual sample rate as shown in Table 15.

### PROGRAMMABLE NOTCH FILTER

A programmable notch filter is provided. This filter has a variable centre frequency and bandwidth, programmable via two coefficients, a0 and a1. a0 and a1 are represented by the register bits NFA0[13:0] and NFA1[13:0]. Because these coefficient values require four register writes to setup there is an NFU (Notch Filter Update) flag which should be set only when all four registers are setup.

REGISTER ADDRESS	BIT	LABEL	DEFAULT	DESCRIPTION
R27 Notch Filter 1	6:0	NFA0[13:7]	0	Notch Filter a0 coefficient, bits [13:7]
	7	NFEN	0	Notch filter enable: 0 = Disabled 1 = Enabled
	8	NFU	0	Notch filter update. The notch filter values used internally only update when one of the NFU bits is set high.
R28 Notch Filter 2	6:0	NFA0[6:0]	0	Notch Filter a0 coefficient, bits [6:0]
	8	NFU	0	Notch filter update. The notch filter values used internally only update when one of the NFU bits is set high.
R29 Notch Filter 3	6:0	NFA1[13:7]	0	Notch Filter a1 coefficient, bits [13:7]
	8	NFU	0	Notch filter update. The notch filter values used internally only update when one of the NFU bits is set high.
R30 Notch Filter 4	0-6	NFA1[6:0]	0	Notch Filter a1 coefficient, bits [6:0]
	8	NFU	0	Notch filter update. The notch filter values used internally only update when one of the NFU bits is set high.

**Table 16 Notch Filter Function**

The coefficients are calculated as follows:

$$a_0 = \frac{1 - \tan(w_b / 2)}{1 + \tan(w_b / 2)}$$

$$a_1 = -(1 + a_0) \cos(w_0)$$

Where:

$$w_0 = 2\pi f_c / f_s$$

$$w_b = 2\pi f_b / f_s$$

$f_c$  = centre frequency in Hz,  $f_b$  = -3dB bandwidth in Hz,  $f_s$  = sample frequency in Hz

The actual register values can be determined from the coefficients as follows:

$$\text{NFA0} = -a_0 \times 2^{13}$$

$$\text{NFA1} = -a_1 \times 2^{12}$$

### DIGITAL ADC VOLUME CONTROL

The output of the ADCs can be digitally attenuated over a range from -127dB to 0dB in 0.5dB steps. The gain for a given eight-bit code X is given by:

$$0.5 \times (G-255) \text{ dB for } 1 \leq G \leq 255; \quad \text{MUTE for } G = 0$$

REGISTER ADDRESS	BIT	LABEL	DEFAULT	DESCRIPTION
R15 Left channel ADC Digital Volume	7:0	ADCLVOL [7:0]	11111111 ( 0dB )	Left ADC Digital Volume Control 0000 0000 = Digital Mute 0000 0001 = -127dB 0000 0010 = -126.5dB ... 0.5dB steps up to 1111 1111 = 0dB
	8	ADCVU	Not latched	ADC left and ADC right volume do not update until a 1 is written to ADCVU (in reg 15 or 16)
R16 Right channel ADC Digital Volume	7:0	ADCRVOL [7:0]	11111111 ( 0dB )	Right ADC Digital Volume Control 0000 0000 = Digital Mute 0000 0001 = -127dB 0000 0010 = -126.5dB ... 0.5dB steps up to 1111 1111 = 0dB
	8	ADCVU	Not latched	ADC left and ADC right volume do not update until a 1 is written to ADCVU (in reg 15 or 16)

Table 17 ADC Digital Volume Control

### INPUT LIMITER / AUTOMATIC LEVEL CONTROL (ALC)

The WM8758B has an automatic PGA gain control circuit, which can function as an input peak limiter or as an automatic level control (ALC).

In input peak limiter mode (ALCMODE bit = 1), a digital peak detector detects when the input signal goes above a predefined level and will ramp the PGA gain down to prevent the signal becoming too large for the input range of the ADC. When the signal returns to a level below the threshold, the PGA gain is slowly returned to its starting level. The peak limiter cannot increase the PGA gain above its static level.

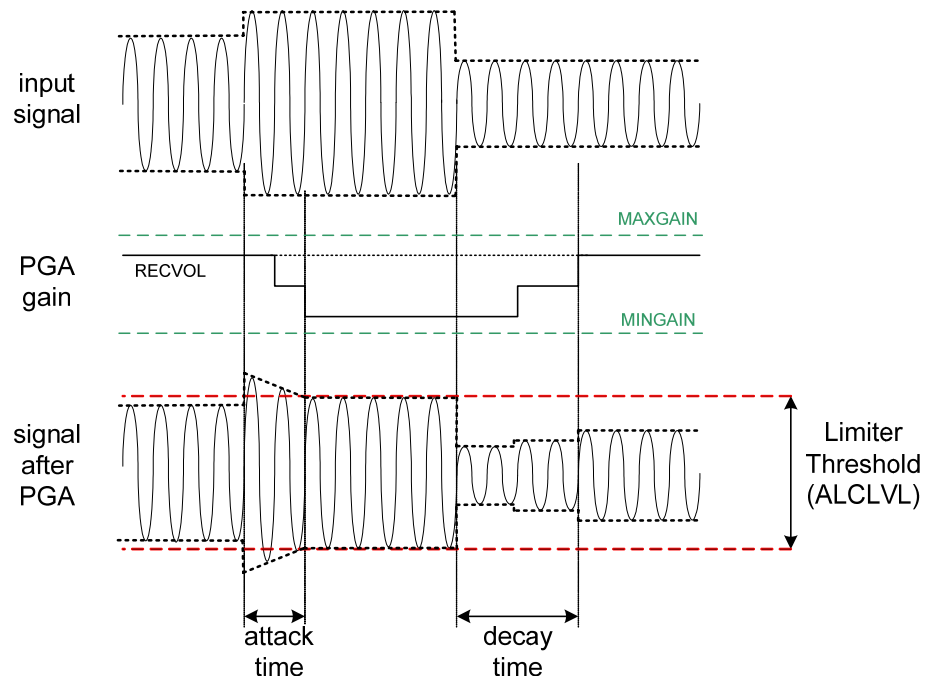
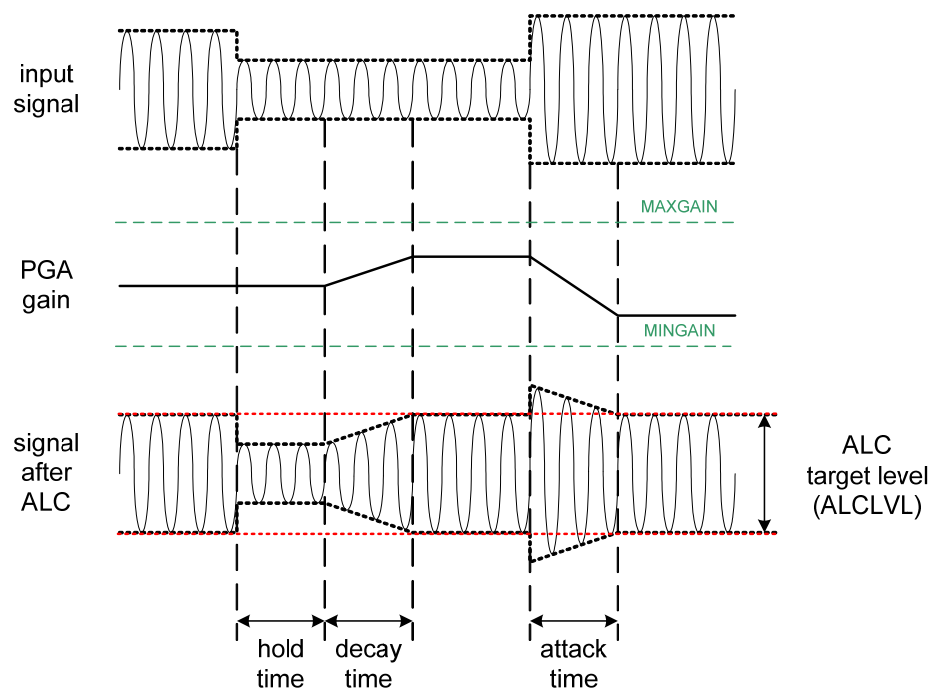


Figure 20 Input Peak Limiter Operation

In ALC mode (ALCMODE bit = 0) the circuit aims to keep a constant recording volume irrespective of the input signal level. This is achieved by continuously adjusting the PGA gain so that the signal level at the ADC input remains constant. A digital peak detector monitors the ADC output and changes the PGA gain if necessary.



**Figure 21 ALC Operation**

The ALC/Limiter function is enabled by setting the register bit ALCSEL. When enabled, the recording volume can be programmed between  $-1\text{dB}$  and  $-22.5\text{dB}$  (relative to ADC full scale) using the ALCLVL register bits. An upper limit for the PGA gain can be imposed by setting the ALCMAX control bits and a lower limit for the PGA gain can be imposed by setting the ALCMIN control bits.

ALCHLD, ALCDCY and ALCATK control the hold, decay and attack times, respectively:

Hold time is the time delay between the peak level detected being below target and the PGA gain beginning to ramp up. It can be programmed in power-of-two ( $2^n$ ) steps, e.g. 2.67ms, 5.33ms, 10.67ms etc. up to 43.7s. Alternatively, the hold time can also be set to zero. The hold time is not active in limiter mode (ALCMODE = 1). The hold time only applies to gain ramp-up, there is no delay before ramping the gain down when the signal level is above target.

Decay (Gain Ramp-Up) Time is the time that it takes for the PGA gain to ramp up and is given as a time per gain step, time per 6dB change and time to ramp up over 90% of its range. The decay time can be programmed in power-of-two ( $2^n$ ) steps, from 3.3ms/6dB, 6.6ms/6dB, 13.1ms/6dB, etc. to 3.36s/6dB.

Attack (Gain Ramp-Down) Time is the time that it takes for the PGA gain to ramp down and is given as a time per gain step, time per 6dB change and time to ramp down over 90% of its range. The attack time can be programmed in power-of-two ( $2^n$ ) steps, from 832us/6dB, 1.66ms/6dB, 3.328us/6dB, etc. to 852ms/6dB.

NB, In peak limiter mode the gain control circuit runs approximately 4x faster to allow reduction of fast peaks. Attack and Decay times for peak limiter mode are given below.

The hold, decay and attack times given in Table 18 are constant across sample rates so long as the SR bits are set correctly. E.g. when sampling at 48kHz the sample rates stated in Table 18 will only be correct if the SR bits are set to 000 (48kHz). If the actual sample rate was only 44.1kHz then the hold, decay and attack times would be scaled down by 44.1/48.

REGISTER ADDRESS	BIT	LABEL	DEFAULT	DESCRIPTION
R32 ALC Control 1	8:7	ALCSEL	00	ALC function select 00 = ALC disabled 01 = Right channel ALC enabled 10 = Left channel ALC enabled 11 = Both channels ALC enabled
	5:3	ALCMAXGAIN [2:0]	111 (+35.25dB)	Set Maximum Gain of PGA 111 = +35.25dB 110 = +29.25dB 101 = +23.25dB 100 = +17.25dB 011 = +11.25dB 010 = +5.25dB 001 = -0.75dB 000 = -6.75dB
	2:0	ALCMINGAIN [2:0]	000 (-12dB)	Set minimum gain of PGA 000 = -12dB 001 = -6dB 010 = 0dB 011 = +6dB 100 = +12dB 101 = +18dB 110 = +24dB 111 = +30dB
R33 ALC Control 2	7:4	ALCHLD [3:0]	0000 (0ms)	ALC hold time before gain is increased. 0000 = 0ms 0001 = 2.67ms 0010 = 5.33ms ... (time doubles with every step) 1111 = 43.7s
	3:0	ALCLVL [3:0]	1011 (-6dB)	ALC target – sets signal level at ADC input 1111 = -1.5dBFS 1110 = -1.5dBFS 1101 = -3dBFS 1100 = -4.5dBFS ..... (-1.5dB steps) 0001 = -21dBFS 0000 = -22.5dBFS

REGISTER ADDRESS	BIT	LABEL	DEFAULT	DESCRIPTION				
R34 ALC Control 3	8	ALCMODE	0	Determines the ALC mode of operation: 0 = ALC mode 1 = Limiter mode.				
	7:4	ALCDCY [3:0]	0011 (13.1ms/6dB)	Decay (gain ramp-up) time (ALCMODE ==0)				
					Per step	Per 6dB	90% of range	
				0000	410us	3.3ms	24ms	
				0001	820us	6.6ms	48ms	
				0010	1.64ms	13.1ms	192ms	
				... (time doubles with every step)				
				1010 or higher	420ms	3.36s	24.576s	
				0011 (2.9ms/6dB)	Decay (gain ramp-up) time (ALCMODE ==1)			
						Per step	Per 6dB	90% of range
					0000	90.8us	726.4us	5.26ms
	0001	181.6us	1.453ms		10.53ms			
	0010	363.2us	2.905ms		21.06ms			
	... (time doubles with every step)							
	1010	93ms	744ms	5.39s				
3:0	ALCATK [3:0]	0010 (832us/6dB)	ALC attack (gain ramp-down) time (ALCMODE == 0)					
				Per step	Per 6dB	90% of range		
			0000	104us	832us	6ms		
			0001	208us	1.664ms	12ms		
			0010	416us	3.328ms	24.1ms		
			... (time doubles with every step)					
			1010 or higher	106ms	852ms	6.18s		
			0010 (182us/6dB)	ALC attack (gain ramp-down) time (ALCMODE == 1)				
					Per step	Per 6dB	90% of range	
				0000	22.7us	182.4us	1.31ms	
0001	45.4us	363.2us		2.62ms				
0010	90.8us	726.4us		5.26ms				
... (time doubles with every step)								
1010	23.2ms	186ms	1.348s					

Table 18 ALC Control Registers

When the ALC is disabled, the input PGA remains at the last controlled value of the ALC. An input gain update must be made by writing to the INPPGAVOLL/R register bits.



### MINIMUM AND MAXIMUM GAIN

The ALCMINGAIN and ALCMAXGAIN register sets the minimum/maximum gain value that the PGA can be set to whilst under the control of the ALC. This has no effect on the PGA when ALC is not enabled.

### PEAK LIMITER

To prevent clipping when a large signal occurs just after a period of quiet, the ALC circuit includes a limiter function. If the ADC input signal exceeds 87.5% of full scale (-1.16dB), the PGA gain is ramped down at the maximum attack rate (as when ALCATK = 0000), until the signal level falls below 87.5% of full scale. This function is automatically enabled whenever the ALC is enabled.

(Note: If ALCATK = 0000, then the limiter makes no difference to the operation of the ALC. It is designed to prevent clipping when long attack times are used).

### NOISE GATE

When the signal is very quiet and consists mainly of noise, the ALC function may cause "noise pumping", i.e. loud hissing noise during silence periods. The WM8758B has a noise gate function that prevents noise pumping by comparing the signal level at the input pins against a noise gate threshold, NGTH. The noise gate cuts in when:

Signal level at ADC [dBFS] < NGTH [dBFS] + PGA gain [dB] + Mic Boost gain [dB]

This is equivalent to:

Signal level at input pin [dBFS] < NGTH [dBFS]

The PGA gain is then held constant (preventing it from ramping up as it normally would when the signal is quiet).

The table below summarises the noise gate control register. The NGTH control bits set the noise gate threshold with respect to the ADC full-scale range. The threshold is adjusted in 6dB steps. Levels at the extremes of the range may cause inappropriate operation, so care should be taken with set-up of the function. The noise gate only operates in conjunction with the ALC and cannot be used in limiter mode.

REGISTER ADDRESS	BIT	LABEL	DEFAULT	DESCRIPTION
R35 ALC Noise Gate Control	2:0	NGTH	000	Noise gate threshold: 000 = -39dB 001 = -45dB 010 = -51db ... (6dB steps) 111 = -81dB
	3	NGATEN	0	Noise gate function enable 1 = enable 0 = disable

Table 19 ALC Noise Gate Control

## OUTPUT SIGNAL PATH

The WM8758B output signal paths consist of digital application filters, up-sampling filters, stereo Hi-Fi DACs, analogue mixers, stereo headphone and stereo line/mono/midrail output drivers. The digital filters and DAC are enabled by register bits DACENL and DACENR. The mixers and output drivers can be separately enabled by individual control bits (see Analogue Outputs). Thus it is possible to equalizer the analogue mixing and amplification provided by the WM8758B, irrespective of whether the DACs are running or not.

The WM8758B DACs receive digital input data on the DACDAT pin. The digital filter block processes the data to provide the following functions:

- Digital volume control
- Graphic equaliser
- A digital peak limiter.
- Sigma-Delta Modulation

High performance sigma-delta audio DAC converts the digital data into an analogue signal.

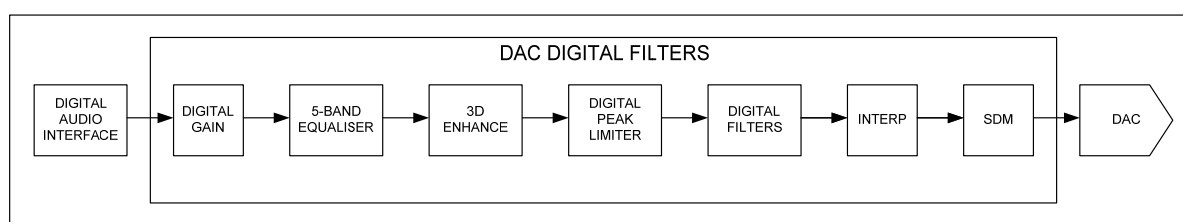


Figure 22 DAC Digital Filter Path

The analogue outputs from the DACs can then be mixed with the ADC analogue inputs. The mix is fed to the output drivers for headphone (LOUT1/ROUT1, LOUT2/ROUT2) or line (OUT3/OUT4). OUT3 and OUT4 have additional mixers which allow them to output different signals to the headphone and line outputs.

### DIGITAL PLAYBACK (DAC) PATH

Digital data is passed to the WM8758B via the flexible audio interface and is then passed through a variety of advanced digital filters as shown in Figure 22 to the hi-fi DACs. The DACs are enabled by the DACENL/R register bits.

REGISTER ADDRESS	BIT	LABEL	DEFAULT	DESCRIPTION
R3 Power Management 3	0	DACENL	0	Left channel DAC enable 0 = DAC disabled 1 = DAC enabled
	1	DACENR	0	Right channel DAC enable 0 = DAC disabled 1 = DAC enabled

Table 20 DAC Enable Control

The WM8758B also has a Soft Mute function, which when enabled, gradually attenuates the volume of the digital signal to zero. When disabled, the gain will ramp back up to the digital gain setting. This function is enabled by default. To play back an audio signal, it must first be disabled by setting the SOFTMUTE bit to zero.

REGISTER ADDRESS	BIT	LABEL	DEFAULT	DESCRIPTION
R10 DAC Control	0	DACPOL	0	Left DAC output polarity: 0 = non-inverted 1 = inverted (180 degrees phase shift)
	1	DACRPOL	0	Right DAC output polarity: 0 = non-inverted 1 = inverted (180 degrees phase shift)
	2	AMUTE	0	Automute enable 0 = Amute disabled 1 = Amute enabled
	3	DACOSR	0	DAC oversampling rate: 0 = 64x (lowest power & best performance) 1 = 128x
	6	SOFTMUTE	0	Softmute enable: 0 = Enabled 1 = Disabled

**Table 21 DAC Control Register**

The digital audio data is converted to oversampled bit streams in the on-chip, true 24-bit digital interpolation filters. The bitstream data enters the multi-bit, sigma-delta DACs, which convert it to a high quality analogue audio signal. The multi-bit DAC architecture reduces high frequency noise and sensitivity to clock jitter. It also uses a Dynamic Element Matching technique for high linearity and low distortion.

The DAC output phase defaults to non-inverted. Setting DACLPOL will invert the DAC output phase on the left channel and DACRPOL inverts the phase on the right channel.

**AUTO-MUTE**

The DAC has an auto-mute function which applies an analogue mute when 1024 consecutive zeros are detected. The mute is released as soon as a non-zero sample is detected. Auto-mute can be disabled using the AMUTE control bit.

**DIGITAL HI-FI DAC VOLUME (GAIN) CONTROL**

The signal volume from each Hi-Fi DAC can be controlled digitally. The gain range is -127dB to 0dB in 0.5dB steps. The level of attenuation for an eight-bit code X is given by:

$$0.5 \times (X-255) \text{ dB for } 1 \leq X \leq 255; \quad \text{MUTE for } X = 0$$

REGISTER ADDRESS	BIT	LABEL	DEFAULT	DESCRIPTION
R11 Left DAC Digital Volume	7:0	DACLVOL [7:0]	11111111 ( 0dB )	Left DAC Digital Volume Control 0000 0000 = Digital Mute 0000 0001 = -127dB 0000 0010 = -126.5dB ... 0.5dB steps up to 1111 1111 = 0dB
	8	DACVU	Not latched	DAC left and DAC right volume do not update until a 1 is written to DACVU (in reg 11 or 12)
R12 Right DAC Digital Volume	7:0	DACRVOL [7:0]	11111111 ( 0dB )	Right DAC Digital Volume Control 0000 0000 = Digital Mute 0000 0001 = -127dB 0000 0010 = -126.5dB ... 0.5dB steps up to 1111 1111 = 0dB
	8	DACVU	Not latched	DAC left and DAC right volume do not update until a 1 is written to DACVU (in reg 11 or 12)

**Table 22 DAC Digital Volume Control**

**Note:** An additional gain of up to 12dB can be added using the gain block embedded in the digital peak limiter circuit (see DAC OUTPUT LIMITER section).

### 5-BAND EQUALISER

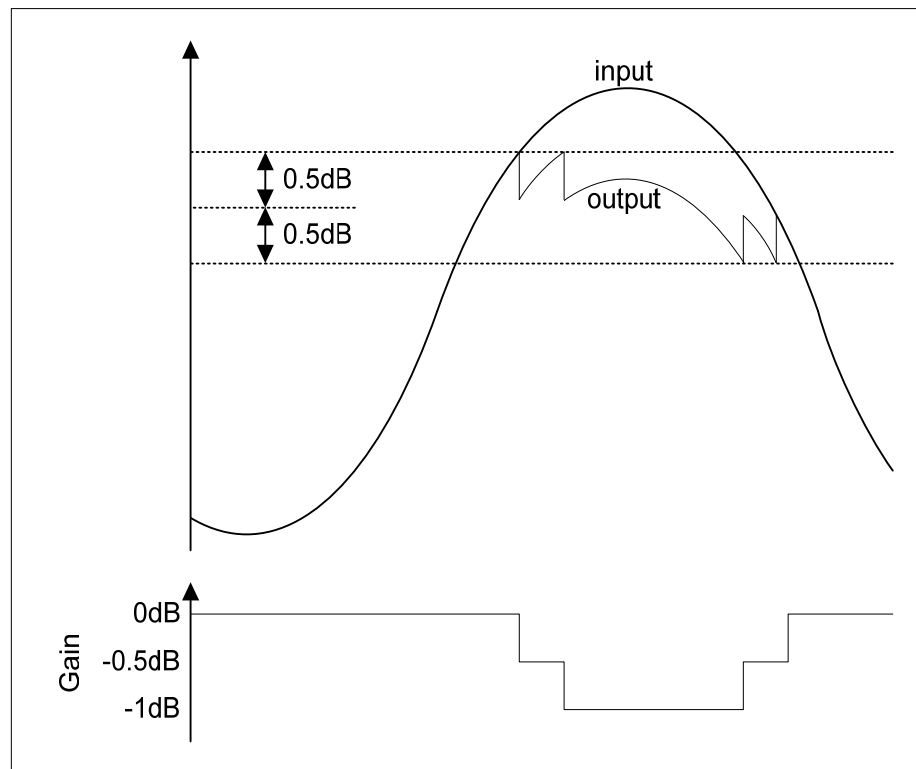
A 5-band graphic equalizer function which can be used to change the output frequency levels to suit the environment. This can be applied to the ADC or DAC path and is described in the 5-BAND EQUALISER section for further details on this feature.

### 3-D ENHANCEMENT

The WM8758B has an advanced digital 3-D enhancement feature which can be used to vary the perceived stereo separation of the left and right channels. Like the 5-band equalizer this feature can be applied to either the ADC record path or the DAC equalizer path but not both simultaneously. Refer to the 3-D STEREO ENHANCEMENT section for further details on this feature.

### DAC DIGITAL OUTPUT LIMITER

The WM8758B has a digital output limiter function. The operation of this is shown in Figure 23. In this diagram the upper graph shows the envelope of the input/output signals and the lower graph shows the gain characteristic.



**Figure 23 DAC Digital Limiter Operation**

The limiter has a programmable upper threshold which is close to 0dB. Referring to Figure 23, in normal operation (LIMBOOST=000 => limit only) signals below this threshold are unaffected by the limiter. Signals above the upper threshold are attenuated at a specific attack rate (set by the LIMATK register bits) until the signal falls below the threshold. The limiter also has a lower threshold 1dB below the upper threshold. When the signal falls below the lower threshold the signal is amplified at a specific decay rate (controlled by LIMDCY register bits) until a gain of 0dB is reached. Both threshold levels are controlled by the LIMLVL register bits. The upper threshold is 0.5dB above the value programmed by LIMLVL and the lower threshold is 0.5dB below the LIMLVL value.

**VOLUME BOOST**

The limiter has programmable upper gain which boosts signals below the threshold to compress the dynamic range of the signal and increase its perceived loudness. This operates as an ALC function with limited boost capability. The volume boost is from 0dB to +12dB in 1dB steps, controlled by the LIMBOOST register bits.

The output limiter volume boost can also be used as a stand alone digital gain boost when the limiter is disabled.

REGISTER ADDRESS	BIT	LABEL	DEFAULT	DESCRIPTION
R24 DAC digital limiter control 1	3:0	LIMATK	0010	Limiter Attack time (per 6dB gain change) for 44.1kHz sampling. Note that these are proportionally related to sample rate. 0000 = 94us 0001 = 188s 0010 = 375us 0011 = 750us 0100 = 1.5ms 0101 = 3ms 0110 = 6ms 0111 = 12ms 1000 = 24ms 1001 = 48ms 1010 = 96ms 1011 to 1111 = 192ms
	7:4	LIMDCY	0011	Limiter Decay time (per 6dB gain change) for 44.1kHz sampling. Note that these are proportionally related to sample rate: 0000 = 750us 0001 = 1.5ms 0010 = 3ms 0011 = 6ms 0100 = 12ms 0101 = 24ms 0110 = 48ms 0111 = 96ms 1000 = 192ms 1001 = 384ms 1010 = 768ms 1011 to 1111 = 1.536s
	8	LIMEN	0	Enable the DAC digital limiter: 0=disabled 1=enabled
R25 DAC digital limiter control 2	3:0	LIMBOOST	0000	Limiter volume boost (can be used as a stand alone volume boost when LIMEN=0): 0000 = 0dB 0001 = +1dB 0010 = +2dB ... (1dB steps) 1011 = +11dB 1100 = +12dB 1101 to 1111 = reserved

REGISTER ADDRESS	BIT	LABEL	DEFAULT	DESCRIPTION
	6:4	LIMLVL	000	Programmable signal threshold level (determines level at which the limiter starts to operate) 000 = -1dB 001 = -2dB 010 = -3dB 011 = -4dB 100 = -5dB 101 to 111 = -6dB

Table 23 DAC Digital Limiter Control

**5-BAND GRAPHIC EQUALISER**

A 5-band graphic equalizer is provided, which can be applied to the ADC or DAC path, together with 3D enhancement, under control of the EQ3DMODE register bit. The ADCs and DACs should be disabled before changing the EQ3DMODE bit.

By default, the WM8758B operates in low power mode, and the DSP core runs at half of the normal rate. In DAC low power mode, only 2-Band equalizer functionality is permitted, where only Band 1 (low shelf) and Band 5 (high shelf) can be used. For ADC low power, the equalizer and 3D cannot be used. To enable full 5-band operation, set M128ENB = 1.

REGISTER ADDRESS	BIT	LABEL	DEFAULT	DESCRIPTION
R18 EQ Control 1	8	EQ3DMODE	1	0 = Equaliser and 3D Enhancement applied to ADC path 1 = Equaliser and 3D Enhancement applied to DAC path

Table 24 EQ and 3D Enhancement DAC or ADC Path Select

The equalizer consists of low and high frequency shelving filters (Band 1 and 5) and three peak filters for the centre bands. Each has adjustable cut-off or centre frequency, and selectable boost (+/- 12dB in 1dB steps). The peak filters have selectable bandwidth.

REGISTER ADDRESS	BIT	LABEL	DEFAULT	DESCRIPTION
R18 EQ Band 1 Control	4:0	EQ1G	01100 (0dB)	Band 1 Gain Control. See Table 30 for details.
	6:5	EQ1C	01	Band 1 Cut-off Frequency: 00 = 80Hz 01 = 105Hz 10 = 135Hz 11 = 175Hz

Table 25 EQ Band 1 Control

REGISTER ADDRESS	BIT	LABEL	DEFAULT	DESCRIPTION
R19 EQ Band 2 Control	4:0	EQ2G	01100 (0dB)	Band 2 Gain Control. See Table 30 for details.
	6:5	EQ2C	01	Band 2 Centre Frequency: 00 = 230Hz 01 = 300Hz 10 = 385Hz 11 = 500Hz
	8	EQ2BW	0	Band 2 Bandwidth Control 0 = narrow bandwidth 1 = wide bandwidth

Table 26 EQ Band 2 Control

REGISTER ADDRESS	BIT	LABEL	DEFAULT	DESCRIPTION
R20 EQ Band 3 Control	4:0	EQ3G	01100 (0dB)	Band 3 Gain Control. See Table 30 for details.
	6:5	EQ3C	01	Band 3 Centre Frequency: 00 = 650Hz 01 = 850Hz 10 = 1.1kHz 11 = 1.4kHz
	8	EQ3BW	0	Band 3 Bandwidth Control 0 = narrow bandwidth 1 = wide bandwidth

Table 27 EQ Band 3 Control

REGISTER ADDRESS	BIT	LABEL	DEFAULT	DESCRIPTION
R21 EQ Band 4 Control	4:0	EQ4G	01100 (0dB)	Band 4 Gain Control. See Table 30 for details
	6:5	EQ4C	01	Band 4 Centre Frequency: 00 = 1.8kHz 01 = 2.4kHz 10 = 3.2kHz 11 = 4.1kHz
	8	EQ4BW	0	Band 4 Bandwidth Control 0 = narrow bandwidth 1 = wide bandwidth

Table 28 EQ Band 4 Control

REGISTER ADDRESS	BIT	LABEL	DEFAULT	DESCRIPTION
R22 EQ Band 5 Gain Control	4:0	EQ5G	01100 (0dB)	Band 5 Gain Control. See Table 30 for details.
	6:5	EQ5C	01	Band 5 Cut-off Frequency: 00 = 5.3kHz 01 = 6.9kHz 10 = 9kHz 11 = 11.7kHz

Table 29 EQ Band 5 Control

GAIN REGISTER	GAIN
00000	+12dB
00001	+11dB
00010	+10dB
.... (1dB steps)	
01100	0dB
01101	-1dB
11000 to 11111	-12dB

Table 30 Gain Register Table

See also Figure 49 to Figure 66 for equaliser and high pass filter responses.



### 3D STEREO ENHANCEMENT

The WM8758B has a digital 3D enhancement option to increase the perceived separation between the left and right channels. Selection of 3D for record or playback is controlled by register bit EQ3DMODE. Switching this bit from record to playback or from playback to record may only be done when ADC and DAC are disabled. The WM8758B control interface will only allow EQ3DMODE to be changed when ADC and DAC are disabled (ie ADCENL = 0, ADCENR = 0, DACENL = 0 and DACENR = 0).

The DEPTH3D setting controls the degree of stereo expansion.

When 3D enhancement is used, it may be necessary to attenuate the signal by 6dB to avoid limiting.

In ADC low power mode (See Power Management section), the equaliser and 3D cannot be used. To enable 3D enhancement and 5-band EQ operation, set M128ENB = 1.

REGISTER ADDRESS	BIT	LABEL	DEFAULT	DESCRIPTION
R41 (29h) 3D Control	3:0	DEPTH3D[3:0]	0000	Stereo depth 0000 = 0% (minimum 3D effect) 0001 = 6.67% .... 1110 = 93.3% 1111 = 100% (maximum 3D effect)

Table 31 3D Stereo Enhancement Function

### ANALOGUE OUTPUTS

The WM8758B has three sets of stereo analogue outputs. These are:

- LOUT1 and ROUT1 which can be used as headphone or line drivers.
- LOUT2 and ROUT2 – which can be used as headphone or line drivers.
- OUT3 and OUT4 – can be configured as a stereo line out (OUT3 is left output and OUT4 is right output). OUT4 can also be used to provide a mono mix of left and right channels.

The outputs LOUT2 and ROUT2 are powered from AVDD2 and are capable of driving a 1V rms signal (AVDD1/3.3).

LOUT1, ROUT1, OUT3 and OUT4 are powered from AVDD1.

LOUT1, ROUT1, LOUT2 and ROUT2 have individual analogue volume PGAs with -57dB to +6dB gain ranges.

There are four output mixers in the output signal path, the left and right channel mixers which control the signals to headphone (and optionally the line outputs) and also dedicated OUT3 and OUT4 mixers.

#### LEFT AND RIGHT OUTPUT CHANNEL MIXERS

The left and right output channel mixers are shown in Figure 24. These mixers allow the ADC bypass and the DAC left and right channels to be combined as desired. This allows a mono mix of the DAC channels to be performed as well as mixing in speech from the input bypass path.

The bypass inputs have individual volume control from -15dB to +6dB and the DAC volume can be adjusted in the digital domain if required. The output of these mixers is connected to both the stereo headphone drivers (LOUT1, ROUT1, LOUT2 and ROUT2) and can optionally be connected to the OUT3 and OUT4 mixers.

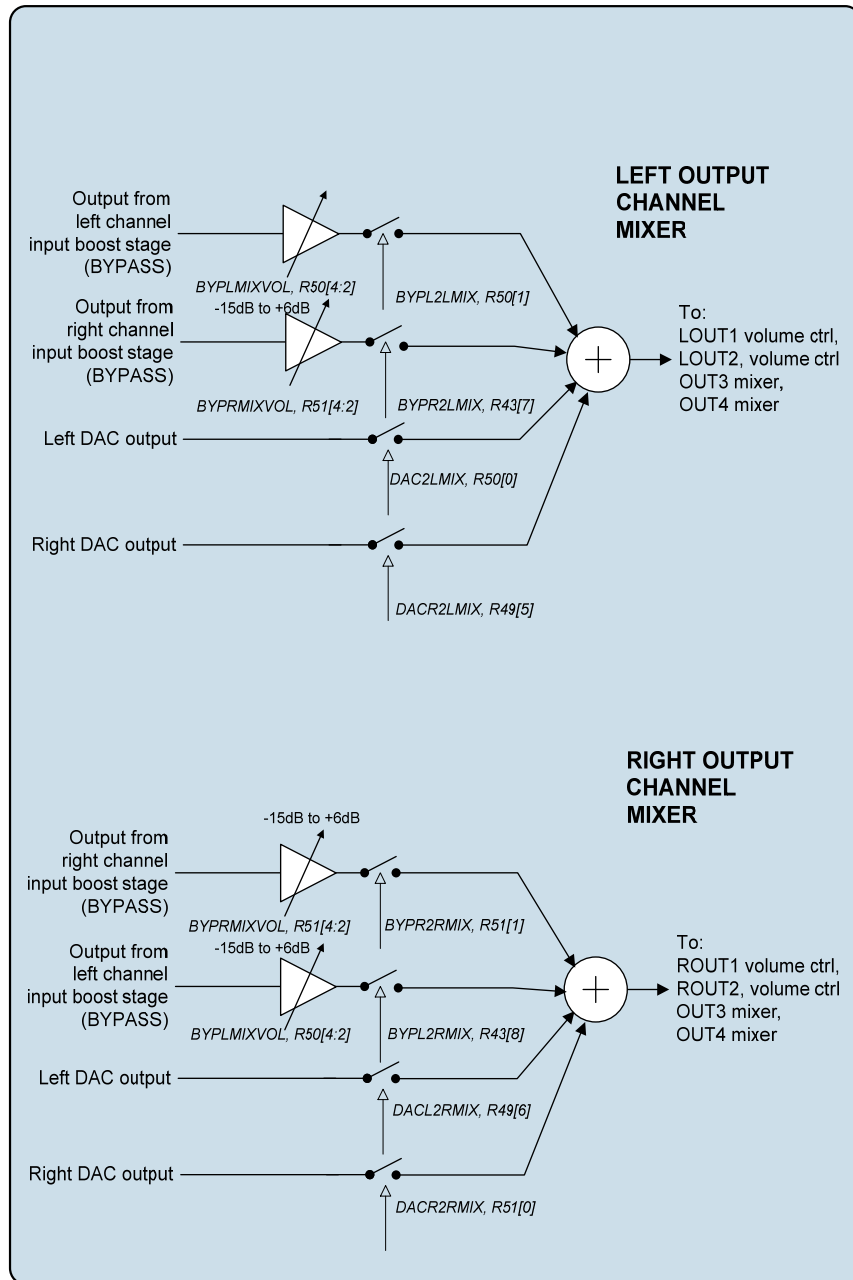


Figure 24 Left/Right Output Channel Mixers

REGISTER ADDRESS	BIT	LABEL	DEFAULT	DESCRIPTION
R43 Output mixer control	8	BYPL2RMIX	0	Left bypass path (from the Left channel input PGA stage) to right output mixer 0 = not selected 1 = selected
R43 Output mixer control	7	BYPR2LMIX	0	Right bypass path (from the right channel input PGA stage) to Left output mixer 0 = not selected 1 = selected
R49 Output mixer control	5	DACR2LMIX	0	Right DAC output to left output mixer 0 = not selected 1 = selected
	6	DACL2RMIX	0	Left DAC output to right output mixer 0 = not selected 1 = selected
R50 Left channel output mixer control	0	DACL2LMIX	0	Left DAC output to left output mixer 0 = not selected 1 = selected
	1	BYPL2LMIX	0	Left bypass path (from the left channel input PGA stage) to left output mixer 0 = not selected 1 = selected
	4:2	BYPLMIXVOL	000	Left bypass volume control to output channel mixer: 000 = -15dB 001 = -12dB ... 101 = 0dB 110 = +3dB 111 = +6dB
R51 Right channel output mixer control	0	DACR2RMIX	0	Right DAC output to right output mixer 0 = not selected 1 = selected
	1	BYPR2RMIX	0	Right bypass path (from the right channel input PGA stage) to right output mixer 0 = not selected 1 = selected
	4:2	BYPRMIXVOL	000	Right bypass volume control to output channel mixer: 000 = -15dB 001 = -12dB ... 101 = 0dB 110 = +3dB 111 = +6dB

REGISTER ADDRESS	BIT	LABEL	DEFAULT	DESCRIPTION
R3 Power management 3	2	LMIXEN	0	Left output channel mixer enable: 0 = disabled 1 = enabled
	3	RMIXEN	0	Right output channel mixer enable: 0 = disabled 1 = enabled

Table 32 Left and Right Output Mixer Control

**HEADPHONE OUTPUTS (LOUT1 AND ROUT1)**

The headphone outputs LOUT1 and ROUT1 can drive a 16Ω or 32Ω headphone load, either through DC blocking capacitors, or DC-coupled to a buffered midrail reference (LOUT2 or ROUT2), saving a capacitor (capless mode). When using capless mode, AVDD1 and AVDD2 should use the same supply to equalize supply rejection. OUT3 and OUT4 should not be used as a buffered midrail reference in capless mode.

Each headphone output has an analogue volume control PGA with a gain range of -57dB to +6dB as shown in Figure 25.

In order to provide common mode rejection of ground noise on the left and right outputs, a headphone common ground feedback option is provided. HP\_COM input may be used as HPCOM common ground feedback signal. This signal is compared to the chip internal midrail voltage and the difference used as the reference input to the headphone output buffer amplifier, as shown in Figure 25, and in more detail in the analog internal circuit diagram.

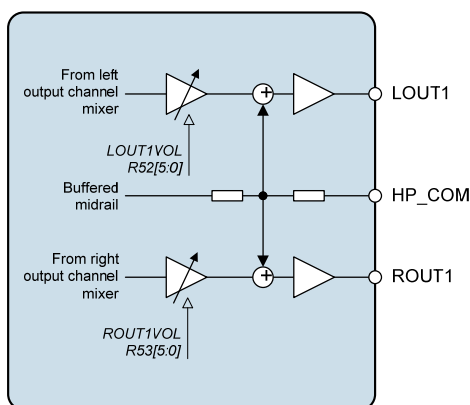


Figure 25 Headphone Outputs LOUT1 and ROUT1

**Headphone Output using DC Blocking Capacitors: with HPCOM common mode feedback applied**

**DC Coupled Headphone Output: no HPCOM feedback**

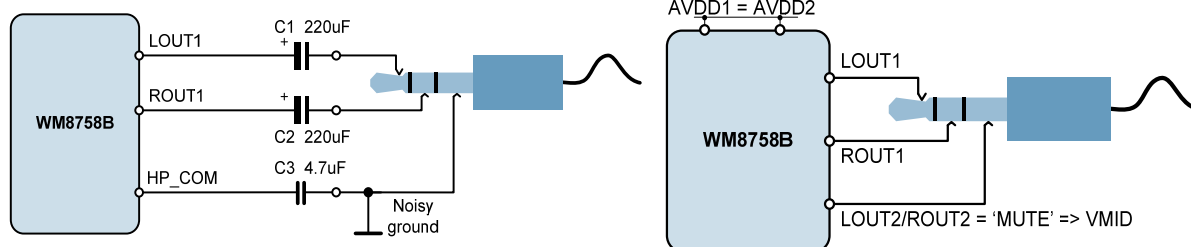


Figure 26 Recommended Headphone Output Configurations

When DC blocking capacitors are used, their capacitance and the load resistance together determine the lower cut-off frequency of the output signal,  $f_c$ . Increasing the capacitance lowers  $f_c$ , improving the bass response. Smaller capacitance values will diminish the bass response. Assuming a  $16\Omega$  load and  $C_1, C_2 = 220\mu\text{F}$ :

$$f_c = 1 / 2\pi R_L C_1 = 1 / (2\pi \times 16\Omega \times 220\mu\text{F}) = 45 \text{ Hz}$$

The AC coupling capacitor into the HP\_COM feedback input requires to be a much smaller value, typically  $4.7\mu\text{F}$  as the internal resistance it is driving into is typically  $22\text{k}\Omega$ .

In the DC coupled configuration, the headphone pseudo-ground is connected to the buffered midrail reference pin (LOUT2 or ROUT2). The L/ROUT2 pins can be configured as a DC output driver by setting the LOUT2MUTE and ROUT2MUTE register bits. The DC voltage on VMID in this configuration is equal to the DC offset on the LOUT1 and ROUT1 pins therefore no DC blocking capacitors are required. This saves space and material cost in portable applications.

It is not recommended to use DC-coupling to line inputs of another device. Although the built-in short circuit protection on the headphone outputs would be tolerant of shorts to ground, such a connection may be noisy, and may not function properly if the other device is grounded. DC-coupled configurations should only be used with headphones.

#### COMMON MODE DEFAULT

The common mode feedback mode is enabled by writing a 1 to HP\_COM or LINE\_COM (reg 49 bits 7 and 8). Under normal operation these registers default 0 (common mode disabled). However the polarity of these registers can be inverted by using 2-wire control interface mode and holding the CSB\_GPIO1 pin high. In this mode of operation HP\_COM=0 enables HP common mode, and HP\_COM=1 disables HP common mode. Similarly LINE\_COM=0 enables LINE common mode and LINE\_COM=1 disables LINE common mode. Note that if the CSB\_GPIO1 is configured as a GPIO the operation of HP\_COM and LINE\_COM revert back to non-inverted operation.

REGISTER ADDRESS	BIT	LABEL	DEFAULT	DESCRIPTION
R49	8	HP_COMEN	0	Headphone common ground enable: 1 = Use external common ground 0 = use internal VMID
			0	Function inverts if MODE = 2-wire And CSB/GPIO1 = 'hi' 0 = Use external common ground 1 = Use internal VMID
R52 LOUT1 Volume control	7	LOUT1ZC	0	Headphone volume zero cross enable: 1 = Change gain on zero cross only 0 = Change gain immediately
	6	LOUT1MUTE	0	Left headphone output mute: 0 = Normal operation 1 = Mute
	5:0	LOUT1VOL	111001	Left headphone output volume: 000000 = -57dB ... 111001 = 0dB ... 111111 = +6dB
	8	HPVU	Not latched	LOUT1 and ROUT1 volumes do not update until a 1 is written to HPVU (in reg 52 or 53)
R53 ROUT1 Volume control	7	ROUT1ZC	0	Headphone volume zero cross enable: 1 = Change gain on zero cross only 0 = Change gain immediately
	6	ROUT1MUTE	0	Right headphone output mute: 0 = Normal operation 1 = Mute
	5:0	ROUT1VOL	111001	Right headphone output volume: 000000 = -57dB ... 111001 = 0dB ... 111111 = +6dB
	8	HPVU	Not latched	LOUT1 and ROUT1 volumes do not update until a 1 is written to HPVU (in reg 52 or 53)

Table 33 OUT1 Volume Control

### HEADPHONE OUTPUTS (LOUT2 AND ROUT2)

The outputs LOUT2 and ROUT2 are designed to drive two headphone loads of 16Ω or 32Ω or line outputs (See Headphone Output and Line Output sections, respectively). Each output has an individual volume control PGA, a mute and an enable control bit as shown in Figure 27. LOUT2 and ROUT2 output the left and right channel mixer outputs respectively.

The LOUT2/ROUT2 outputs also have the option of incorporating common ground feedback from the output signal ground, via a connection to the LINE\_COM input. This common ground feedback signal should be AC-coupled via a 4.7uF capacitor as for the headphone common mode feedback path. AC coupling of these outputs if they are used as LINE level outputs requires similar 1 to 4.7uF AC coupling capacitors depending upon LINE load resistance.

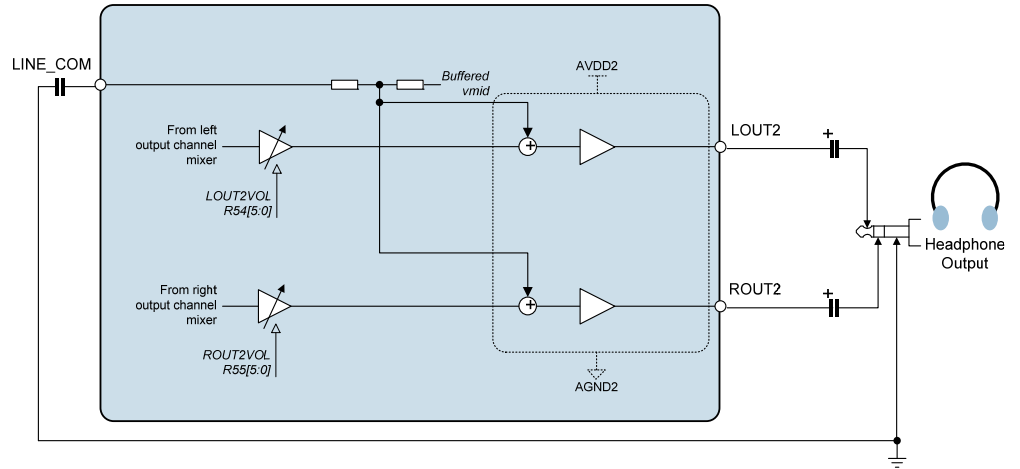


Figure 27 LOUT2 and ROUT2 Headphone Configuration with Feedback

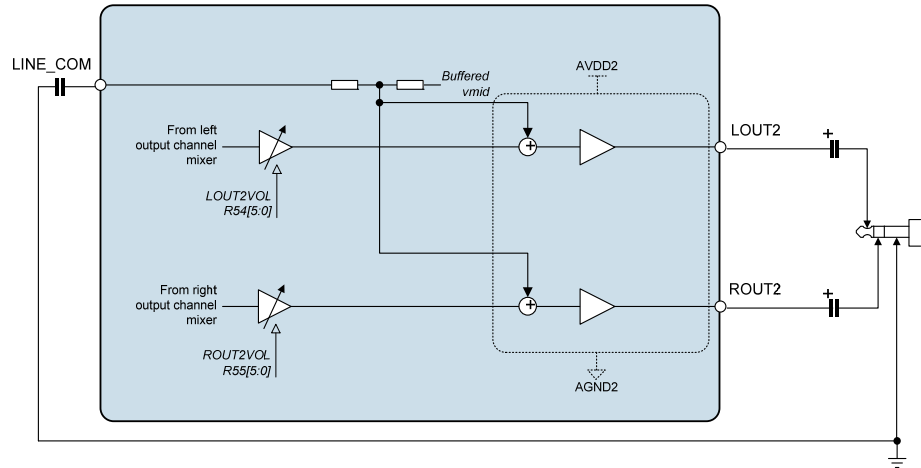


Figure 28 LOUT2 and ROUT2 Line Output Configuration with Feedback

The signal output on LOUT2/ROUT2 comes from the Left/Right Mixer circuits and can be any combination of the DAC output and the bypass path (output of the input boost stage). The LOUT2/ROUT2 volume is controlled by the LOUT2VOL/ ROUT2VOL register bits. Gains over 0dB may cause clipping if the input signal is too high. The LOUT2MUTE/ ROUT2MUTE register bits cause these outputs to be muted (the output DC level is driven out). The output pins remain at the same DC level, so that no click noise is produced when muting or un-muting.

REGISTER ADDRESS	BIT	LABEL	DEFAULT	DESCRIPTION
R49	7	LINE_COMEN	0	Line common ground enable: 1 = Use external common ground 0 = use internal VMID
			0	Function inverts if MODE = 2-wire And CSB/GPIO1 = 'hi' 0 = Use external common ground 1 = Use internal VMID

Table 34 Line Common Control

REGISTER ADDRESS	BIT	LABEL	DEFAULT	DESCRIPTION
R54 LOUT2 Volume control	7	LOUT2ZC	0	LOUT2 volume zero cross enable: 1 = Change gain on zero cross only 0 = Change gain immediately
	6	LOUT2MUTE	0	Left output mute: 0 = Normal operation 1 = Mute
	5:0	LOUT2VOL	111001	Left output volume: 000000 = -57dB ... 111001 = 0dB ... 111111 = +6dB
	8	SPKVU	Not latched	LOUT2 and ROUT2 volumes do not update until a 1 is written to SPKVU (in reg 54 or 55)
R55 ROUT2 Volume control	7	ROUT2ZC	0	ROUT2 volume zero cross enable: 1 = Change gain on zero cross only 0 = Change gain immediately
	6	ROUT2MUTE	0	Right output mute: 0 = Normal operation 1 = Mute
	5:0	ROUT2VOL	111001	Right output volume: 000000 = -57dB ... 111001 = 0dB ... 111111 = +6dB
	8	SPKVU	Not latched	LOUT2 and ROUT2 volumes do not update until a 1 is written to SPKVU (in reg 54 or 55)

Table 35 OUT2 Volume Control

**ZERO CROSS TIMEOUT**

A zero-cross timeout function is provided so that if zero cross is enabled on the input or output PGAs the gain will automatically update after a timeout period if a zero cross has not occurred. This is enabled by setting SLOWCLKEN. The timeout period is dependent on the clock input to the digital and is equal to  $2^{21} * \text{SYSCLK period}$ .

REGISTER ADDRESS	BIT	LABEL	DEFAULT	DESCRIPTION
R7 Additional Control	0	SLOWCLKEN	0	Slow clock enable. Used for both the jack insert detect debounce circuit and the zero cross timeout. 0 = slow clock disabled 1 = slow clock enabled

Table 36 Timeout Clock Enable Control



### OUT3/OUT4 MIXERS AND OUTPUT STAGES

The OUT3/OUT4 pins provide an additional stereo line output, a mono output, or a differential line output. There is a dedicated analogue mixer for OUT3 and one for OUT4 as shown in Figure 29.

The OUT3 and OUT4 output stages are powered from AVDD1 and AGND1.

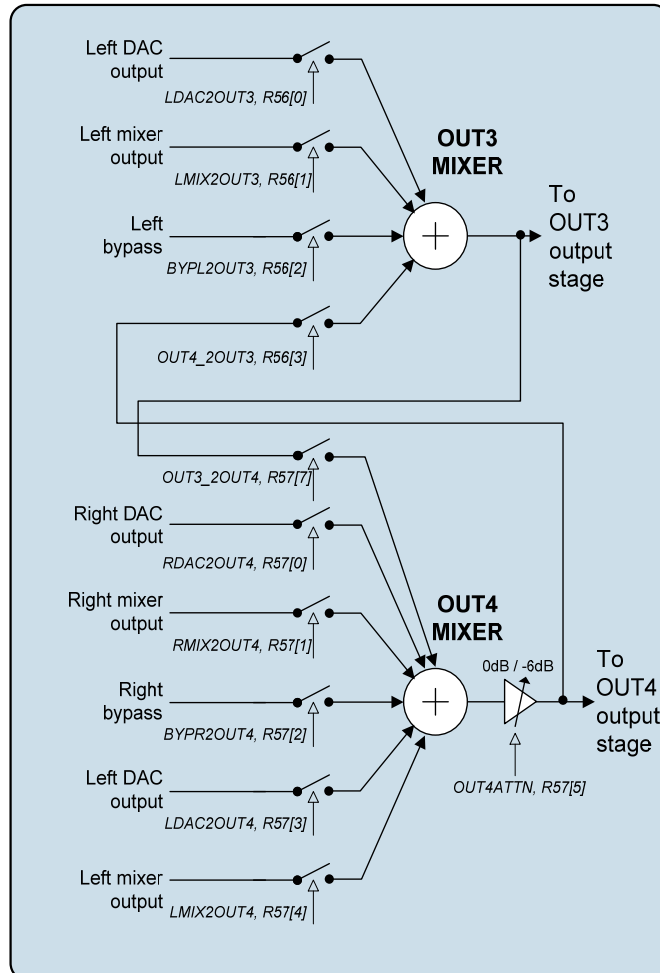


Figure 29 OUT3 and OUT4 Mixers

OUT3 can provide a midrail reference, a left line output, or a mono mix line output.

OUT4 can provide a midrail reference, a right line output, or a mono mix line output.

Note: OUT3 and OUT4 should not be used as a buffered midrail pseudo GND in capless mode.

A 6dB attenuation function is provided for OUT4, to prevent clipping during mixing of left and right signals. This function is enabled by the OUT4ATTN register bit.

REGISTER ADDRESS	BIT	LABEL	DEFAULT	DESCRIPTION
R56 OUT3 mixer control	6	OUT3MUTE	0	0 = Output stage outputs OUT3 mixer 1 = Output stage muted – drives out VMID. Can be used as VMID reference in this mode. (Not to be used for Capless HP pseudo GND)
	3	OUT4_2OUT3	0	OUT4 mixer output to OUT3 0 = disabled 1 = enabled
	2	BYPL2OUT3	0	Left ADC input to OUT3 0 = disabled 1 = enabled
	1	LMIX2OUT3	0	Left DAC mixer to OUT3 0 = disabled 1 = enabled
	0	LDAC2OUT3	1	Left DAC output to OUT3 0 = disabled 1 = enabled
R57 OUT4 mixer control	7	OUT3_2OUT4	0	OUT3 mixer output to OUT4 0 = disabled 1 = enabled
	6	OUT4MUTE	0	0 = Output stage outputs OUT4 mixer 1 = Output stage muted – drives out VMID. Can be used as VMID reference in this mode. (Not to be used for Capless HP pseudo GND)
	5	OUT4ATTN	0	0 = OUT4 normal output 1 = OUT4 attenuated by 6dB
	4	LMIX2OUT4	0	Left DAC mixer to OUT4 0 = disabled 1 = enabled
	3	LDAC2OUT4	0	Left DAC to OUT4 0 = disabled 1 = enabled
	2	BYPR2OUT4	0	Right ADC input to OUT4 0 = disabled 1 = enabled
	1	RMIX2OUT4	0	Right DAC mixer to OUT4 0 = disabled 1 = enabled
	0	RDAC2OUT4	1	Right DAC output to OUT4 0 = disabled 1 = enabled

Table 37 OUT3/OUT4 Mixer Registers

### ENABLING THE OUTPUTS

Each analogue output of the WM8758B can be independently enabled or disabled. The analogue mixer associated with each output has a separate enable bit. All outputs are disabled by default. To save power, unused parts of the WM8758B should remain disabled.

Outputs can be enabled at any time, but it is not recommended to do so when BUFIO is disabled (BUFIOEN=0), as this may cause pop noise (see “Power Management” and “Applications Information” sections).

REGISTER ADDRESS	BIT	LABEL	DEFAULT	DESCRIPTION
R1 Power Management 1	2	BUFIOEN	0	Unused input/output bias buffer enable
	6	OUT3MIXEN	0	OUT3 mixer enable
	7	OUT4MIXEN	0	OUT4 mixer enable
R2 Power Management 2	8	ROUT1EN	0	ROUT1 output enable
	7	LOUT1EN	0	LOUT1 output enable
	6	SLEEP	0	0 = Normal device operation 1 = Supply current reduced in device standby mode (see note)
R3 Power Management 3	2	LMIXEN	0	Left mixer enable
	3	RMIXEN	0	Right mixer enable
	5	ROUT2EN	0	ROUT2 output enable
	6	LOUT2EN	0	LOUT2 output enable
	7	OUT3EN	0	OUT3 enable
	8	OUT4EN	0	OUT4 enable
<b>Note:</b> All “Enable” bits are 1 = ON, 0 = OFF				

**Table 38 Output Stages Power Management Control**

Note: The SLEEP bit R2[6] should only be used when the device is already in standby mode. The SLEEP bit prevents the MCLK from propagating round the device when the external MCLK signal cannot be removed.

### THERMAL SHUTDOWN

To protect the WM8758B from becoming too hot, a thermal sensor has been built in. If the chip temperature reaches approximately 150°C and the TSDEN and TSOPCTRL bit are set, then all outputs will be disabled to avoid further increase of the chip temperature.

Additionally, when the device is too hot and TSDEN is set, then the WM8758B de-asserts GPIO bit 11, a virtual GPIO that can be set up to generate an interrupt to the CPU (see “GPIO and Interrupt Control” section).

REGISTER ADDRESS	BIT	LABEL	DEFAULT	DESCRIPTION
R49 Output Control	1	TSDEN	0	Thermal Sensor Enable 0 = disabled 1 = enabled
	2	TSOPCTRL	0	Thermal Shutdown Output enable 0 = Disabled 1 = Enabled, i.e. all outputs will be disabled if T1 set, i.e. temperature above 150°C

**Table 39 Thermal Shutdown**

### UNUSED ANALOGUE INPUTS/OUTPUTS

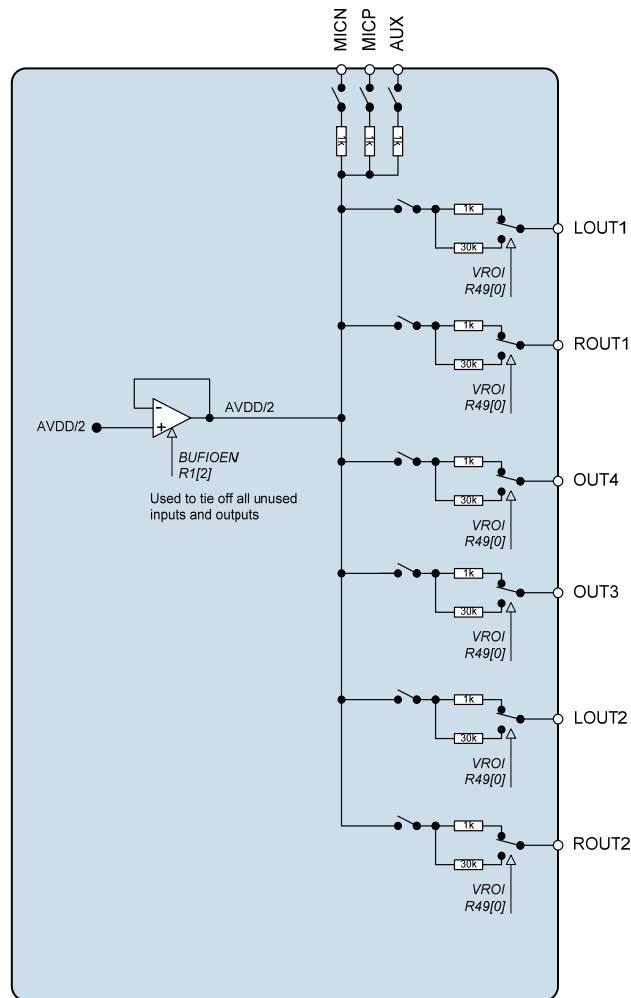
Whenever an analogue input/output is disabled, it remains connected to a voltage source (AVDD1/2) through a resistor. This helps to prevent pop noise when the output is re-enabled. The resistance between the voltage buffer and the output pins can be controlled using the VROI control bit. The default impedance is low, so that any capacitors on the outputs can charge up quickly at start-up. If a high impedance is desired for disabled outputs, VROI can then be set to 1, increasing the resistance to about 30kΩ.

REGISTER ADDRESS	BIT	LABEL	DEFAULT	DESCRIPTION
R49	0	VROI	0	VREF (AVDD1/2) to analogue output resistance 0 = approx 1kΩ 1 = approx 30 kΩ

**Table 40 Disabled Outputs to VREF Resistance**

A dedicated buffer is available for biasing unused analogue I/O pins as shown in Figure 30. This buffer can be enabled using the BUFIOEN register bit.

Figure 30 summarises the bias options for the output pins.



**Figure 30 Unused Input/Output Pin Tie-off Buffers**

L/ROUT2EN/ OUT3/4EN	VROI	OUTPUT CONFIGURATION
0	0	1kΩ to AVDD1/2
0	1	30kΩ to AVDD1/2
1	X	Output enabled (DC level=AVDD1/2)

**Table 41 Unused Output Pin Bias Options**

## DIGITAL AUDIO INTERFACES

The audio interface has four pins:

- ADCDAT: ADC data output
- DACDAT: DAC data input
- LRC: Data Left/Right alignment clock
- BCLK: Bit clock, for synchronisation

The clock signals BCLK, and LRC can be outputs when the WM8758B operates as a master, or inputs when it is a slave (see Master and Slave Mode Operation, below).

Five different audio data formats are supported:

- Left justified
- Right justified
- I<sup>2</sup>S
- DSP mode A
- DSP mode B

All of these modes are MSB first. They are described in Audio Data Formats, below. Refer to the Electrical Characteristic section for timing information.

### MASTER AND SLAVE MODE OPERATION

The WM8758B audio interface may be configured as either master or slave. As a master interface device the WM8758B generates BCLK and LRC and thus controls sequencing of the data transfer on ADCDAT and DACDAT. To set the device to master mode register bit MS should be set high. In slave mode (MS=0), the WM8758B responds with data to clocks it receives over the digital audio interfaces.

In master mode, the BCLK and LRC clocks are not stopped when the ADC's are disabled using register R2[1:0] and the DAC's are disabled using register R3[:0]. The ADCDAT pin continuously outputs the last word of data which was transmitted when the ADC was disabled. To prevent this in master mode, it is necessary to disable the ADC's R2[1:0] and DAC's R3[:0] and remove the MCLK input clock OR by switching the digital audio interface to slave mode.

### AUDIO DATA FORMATS

In Left Justified mode, the MSB is available on the first rising edge of BCLK following an LRC transition. The other bits up to the LSB are then transmitted in order. Depending on word length, BCLK frequency and sample rate, there may be unused BCLK cycles before each LRC transition.

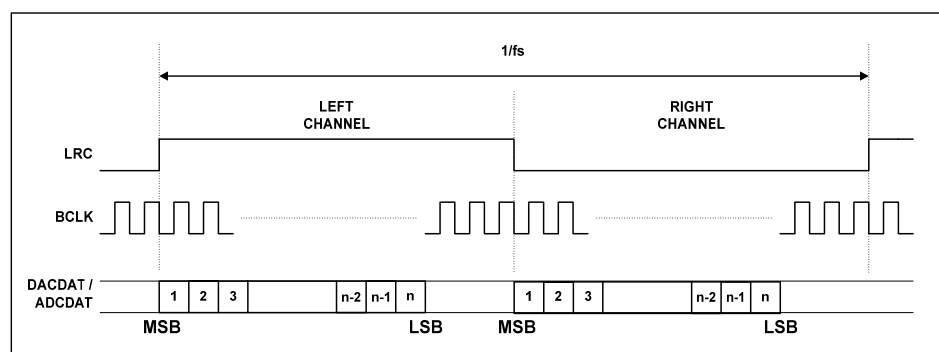


Figure 31 Left Justified Audio Interface (assuming n-bit word length)

In Right Justified mode, the LSB is available on the last rising edge of BCLK before a LRC transition. All other bits are transmitted before (MSB first). Depending on word length, BCLK frequency and sample rate, there may be unused BCLK cycles after each LRC transition.

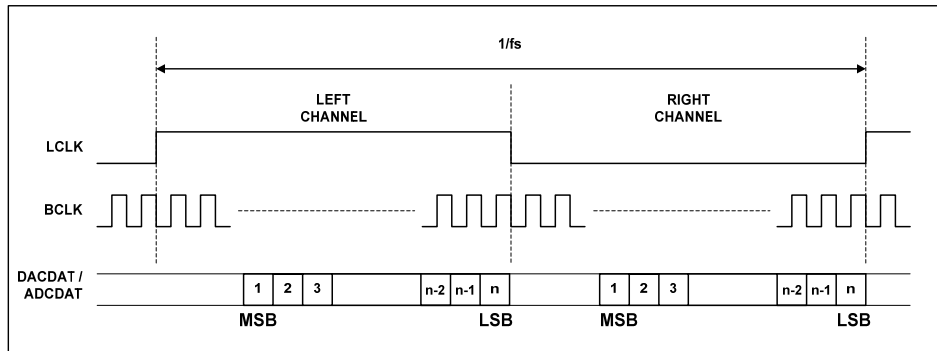


Figure 32 Right Justified Audio Interface (assuming n-bit word length)

In I<sup>2</sup>S mode, the MSB is available on the second rising edge of BCLK following a LRC transition. The other bits up to the LSB are then transmitted in order. Depending on word length, BCLK frequency and sample rate, there may be unused BCLK cycles between the LSB of one sample and the MSB of the next.

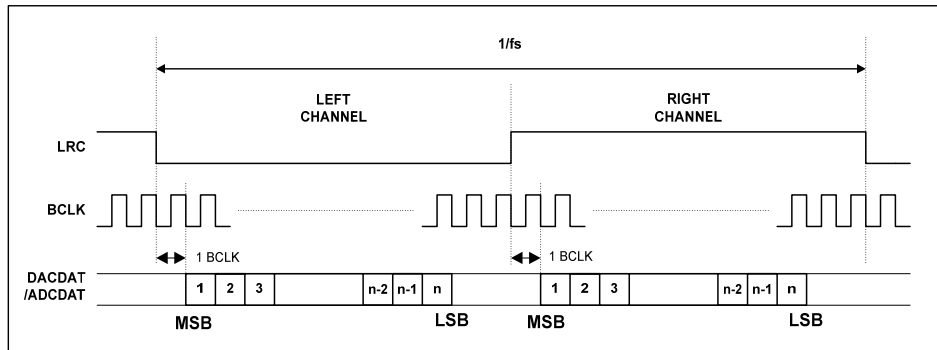


Figure 33 I<sup>2</sup>S Audio Interface (assuming n-bit word length)

In DSP/PCM mode, the left channel MSB is available on either the 1<sup>st</sup> (mode B) or 2<sup>nd</sup> (mode A) rising edge of BCLK (selectable by LRP) following a rising edge of LRC. Right channel data immediately follows left channel data. Depending on word length, BCLK frequency and sample rate, there may be unused BCLK cycles between the LSB of the right channel data and the next sample.

In device master mode, the LRC output will resemble the LRC pulse shown in Figure 34 and Figure 35. In device slave mode, Figure 36 and Figure 37, it is possible to use any length of LRC pulse less than 1/fs, providing the falling edge of the LRC pulse occurs greater than one BCLK period before the rising edge of the next LRC pulse.

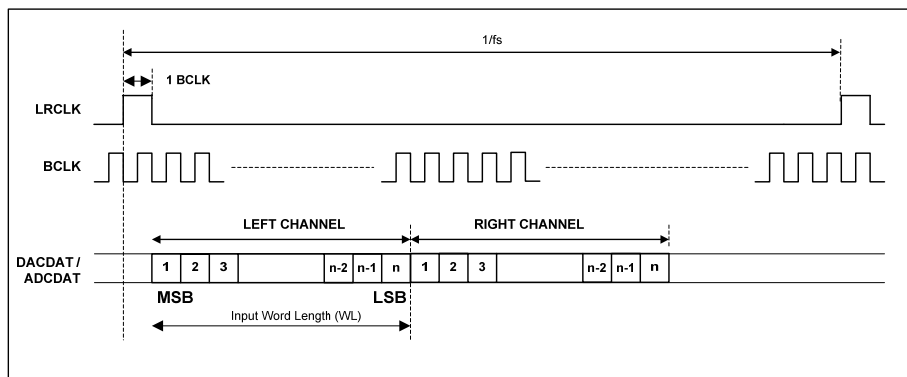


Figure 34 DSP/PCM Mode Audio Interface (mode A, LRP=0, Master)

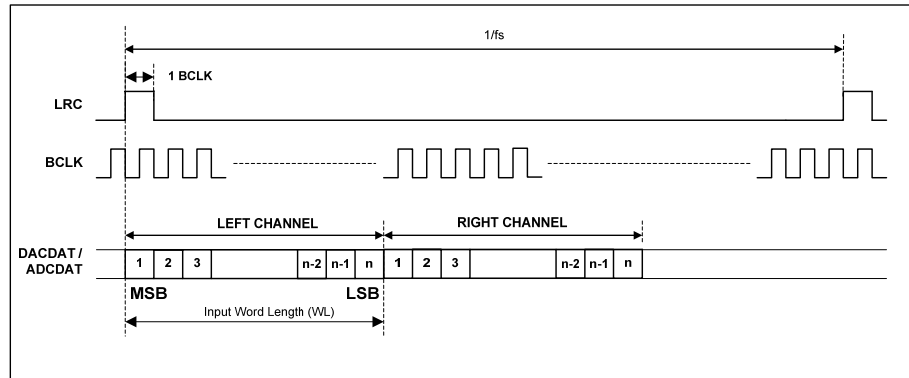


Figure 35 DSP/PCM Mode Audio Interface (mode B, LRP=1, Master)

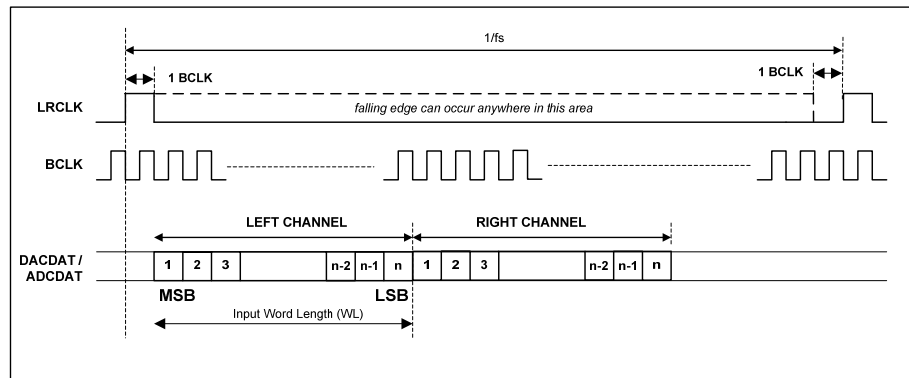


Figure 36 DSP/PCM Mode Audio Interface (mode A, LRP=0, Slave)

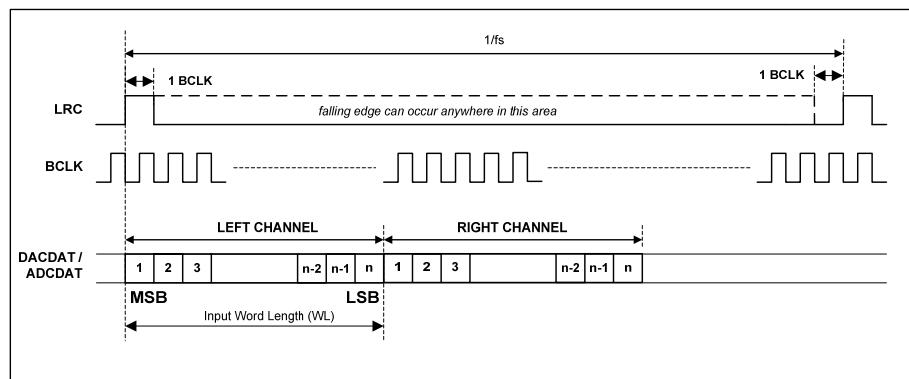


Figure 37 DSP/PCM Mode Audio Interface (mode B, LRP=0, Slave)

REGISTER ADDRESS	BIT	LABEL	DEFAULT	DESCRIPTION
R4 Audio Interface Control	0	MONO	0	Selects between stereo and mono device operation: 0 = Stereo device operation 1 = Mono device operation. Data appears in 'left' phase of LRC.
	1	ADCLRSWAP	0	Controls whether ADC data appears in 'right' or 'left' phases of LRC clock: 0 = ADC left data appear in 'left' phase of LRC and right data in 'right' phase 1 = ADC left data appear in 'right' phase of LRC and right data in 'left' phase
	2	DACLRSWAP	0	Controls whether DAC data appears in 'right' or 'left' phases of LRC clock: 0 = DAC left data appear in 'left' phase of LRC and right data in 'right' phase 1 = DAC left data appear in 'right' phase of LRC and right data in 'left' phase
	4:3	FMT	10	Audio interface Data Format Select: 00 = Right Justified 01 = Left Justified 10 = I <sup>2</sup> S format 11 = DSP/PCM mode
	6:5	WL	10	Word length 00 = 16 bits 01 = 20 bits 10 = 24 bits 11 = 32 bits (see note)
	7	LRP	0	RJ, LJ & I <sup>2</sup> S modes – LRC polarity 0 = normal LRC polarity 1 = invert LRC polarity  DSP Mode – mode A/B select 0 = MSB is available on 2 <sup>nd</sup> BCLK rising edge after LRC rising edge (mode A) 1 = MSB is available on 1 <sup>st</sup> BCLK rising edge after LRC rising edge (mode B)
	8	BCP	0	BCLK polarity 0 = normal 1 = inverted
R5	0	LOOPBACK	0	Digital loopback function 0 = No loopback 1 = Loopback enabled, ADC data output is fed directly into DAC data input.

Table 42 Audio Interface Control

**Note:** Right Justified Mode will only operate with a maximum of 24 bits. If 32-bit mode is selected the device will operate in 24-bit mode.

#### AUDIO INTERFACE CONTROL

The register bits controlling audio format, word length and master / slave mode are summarised below.

Register bit MS selects audio interface operation in master or slave mode. In Master mode BCLK and LRC are outputs. The frequency of BCLK and LRC in master mode is controlled with BCLKDIV. These are divided down versions of master clock. This may result in short BCLK pulses at the end of a LRC if there is a non-integer ratio of BCLKs to LRC clocks.



REGISTER ADDRESS	BIT	LABEL	DEFAULT	DESCRIPTION
R6 Clock Generation Control	0	MS	0	Sets the chip to be master over LRC and BCLK 0 = BCLK and LRC clock are inputs 1 = BCLK and LRC clock are outputs generated by the WM8758B (MASTER)
	4:2	BCLKDIV	000	Configures the BCLK and LRC output frequency, for use when the chip is master over BCLK. 000 = divide by 1 (BCLK=SYSCLK) 001 = divide by 2 (BCLK=SYSCLK/2) 010 = divide by 4 011 = divide by 8 100 = divide by 16 101 = divide by 32 110 = reserved 111 = reserved
	7:5	MCLKDIV	010	Sets the scaling for either the MCLK or PLL clock output (under control of CLKSEL) 000 = divide by 1 001 = divide by 1.5 010 = divide by 2 011 = divide by 3 100 = divide by 4 101 = divide by 6 110 = divide by 8 111 = divide by 12
	8	CLKSEL	1	Controls the source of the clock for all internal operation: 0 = MCLK 1 = PLL output

**Table 43 Clock Control**

The CLKSEL bit selects the internal source of the Master clock from the PLL (MCLK=1) or from MCLK (MCLKSEL=0). When the internal clock is switched from one source to another using the CLKSEL bit, the clock originally selected must generate at least one falling edge after CLKSEL has changed for the switching of clocks to be successful.

**EXAMPLE:**

If the PLL is the current source of the internal clock (CLKSEL=1) and it is required to switch to the MCLK, change CLKSEL to select MCLK (CLKSEL=0) and then disable PLL (PLLEN=0).

**LOOPBACK**

Setting the LOOPBACK register bit enables digital loopback. When this bit is set the output data from the ADC audio interface is fed directly into the DAC data input.

**COMPANDING**

The WM8758B supports A-law and  $\mu$ -law companding on both transmit (ADC) and receive (DAC) sides. Companding can be enabled on the DAC or ADC audio interfaces by writing the appropriate value to the DAC\_COMP or ADC\_COMP register bits respectively.

REGISTER ADDRESS	BIT	LABEL	DEFAULT	DESCRIPTION
R5 Companding Control	2:1	ADC_COMP	0	ADC companding 00 = off 01 = reserved 10 = $\mu$ -law 11 = A-law
	4:3	DAC_COMP	0	DAC companding 00 = off 01 = reserved 10 = $\mu$ -law 11 = A-law
	5	WL8	0	0 = off 1 = device operates in 8-bit mode.

**Table 44 Companding Control**

Companding involves using a piecewise linear approximation of the following equations (as set out by ITU-T G.711 standard) for data compression:

$\mu$ -law (where  $\mu=255$  for the U.S. and Japan):

$$F(x) = \ln(1 + \mu|x|) / \ln(1 + \mu) \quad -1 \leq x \leq 1$$

law (where  $A=87.6$  for Europe):

$$F(x) = A|x| / (1 + \ln A) \quad \text{for } x \leq 1/A$$

$$F(x) = (1 + \ln A|x|) / (1 + \ln A) \quad \text{for } 1/A \leq x \leq 1$$

The companded data is also inverted as recommended by the G.711 standard (all 8 bits are inverted for  $\mu$ -law, all even data bits are inverted for A-law). The data will be transmitted as the first 8 MSB's of data.

Companding converts 13 bits ( $\mu$ -law) or 12 bits (A-law) to 8 bits using non-linear quantization. The input data range is separated into 8 levels, allowing low amplitude signals better precision than that of high amplitude signals. This is to exploit the operation of the human auditory system, where louder sounds do not require as much resolution as quieter sounds. The companded signal is an 8-bit word containing sign (1-bit), exponent (3-bits) and mantissa (4-bits).

Setting the WL8 register bit allows the device to operate with 8-bit data. In this mode it is possible to use 8 BCLK's per LRC frame. When using DSP mode B, this allows 8-bit data words to be output consecutively every 8 BCLK's and can be used with 8-bit data words using the A-law and  $\mu$ -law companding functions.

BIT7	BIT[6:4]	BIT[3:0]
SIGN	EXPONENT	MANTISSA

**Table 45 8-bit Companded Word Composition**

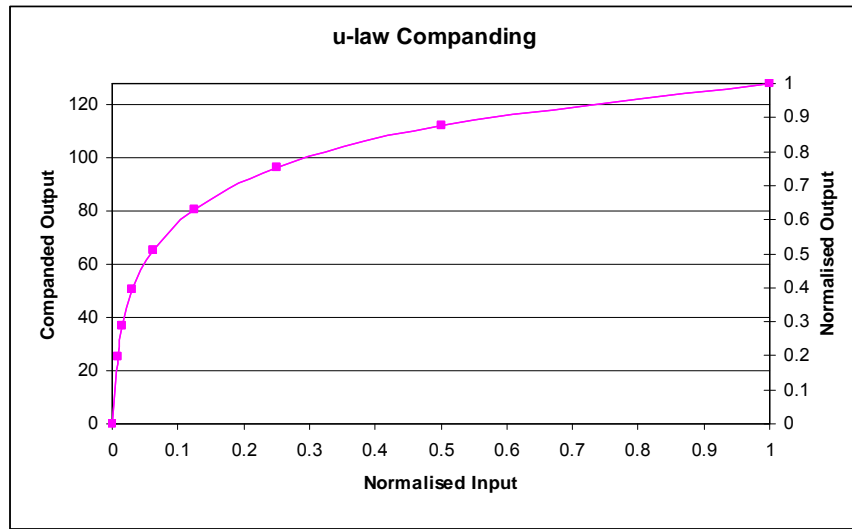


Figure 38  $\mu$ -Law Companding

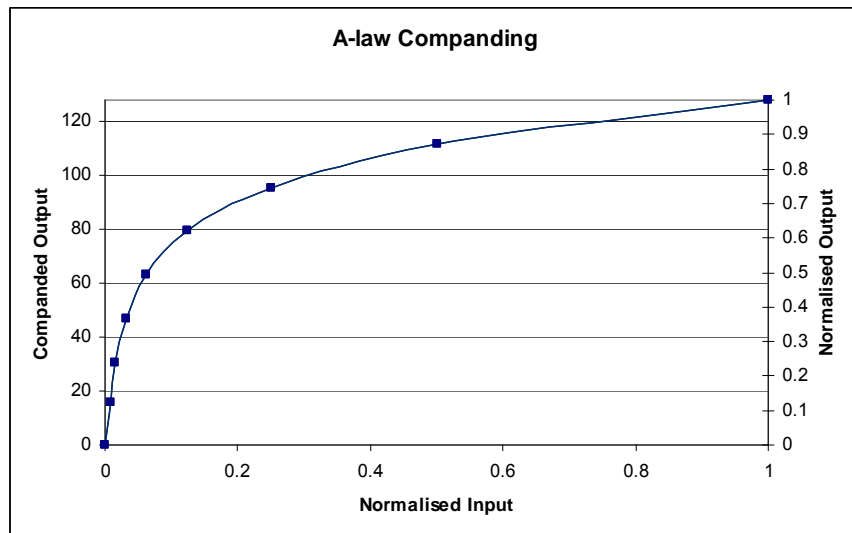


Figure 39 A-Law Companding

## AUDIO SAMPLE RATES

The WM8758B filter characteristics for the ADCs and the DACs are set using the SR register bits. The cutoffs for the digital filters and the ALC attack/decay times stated are determined using these values and assume a 256fs master clock rate.

If a sample rate that is not explicitly supported by the SR register settings is required then the closest SR value to that sample rate should be chosen, the filter characteristics and the ALC attack, decay and hold times will scale appropriately.

REGISTER ADDRESS	BIT	LABEL	DEFAULT	DESCRIPTION
R7 Additional Control	3:1	SR	000	Approximate sample rate (configures the coefficients for the internal digital filters): 000 = 48kHz 001 = 32kHz 010 = 24kHz 011 = 16kHz 100 = 12kHz 101 = 8kHz 110-111 = reserved

Table 46 Sample Rate Control

## MASTER CLOCK AND PHASE LOCKED LOOP (PLL)

The WM8758B has an on-chip phase-locked loop (PLL) circuit that can be used to:

Generate master clocks for the WM8758B audio functions from another external clock, e.g. in telecoms applications.

Generate and output (on pin CSB/GPIO1) a clock for another part of the system that is derived from an existing audio master clock.

Figure 40 shows the PLL and internal clocking on the WM8758B.

The PLL can be enabled or disabled by the PLEN register bit.

REGISTER ADDRESS	BIT	LABEL	DEFAULT	DESCRIPTION
R1 Power management 1	5	PLEN	0	PLL enable 0 = PLL off 1 = PLL on

Table 47 PLEN Control Bit

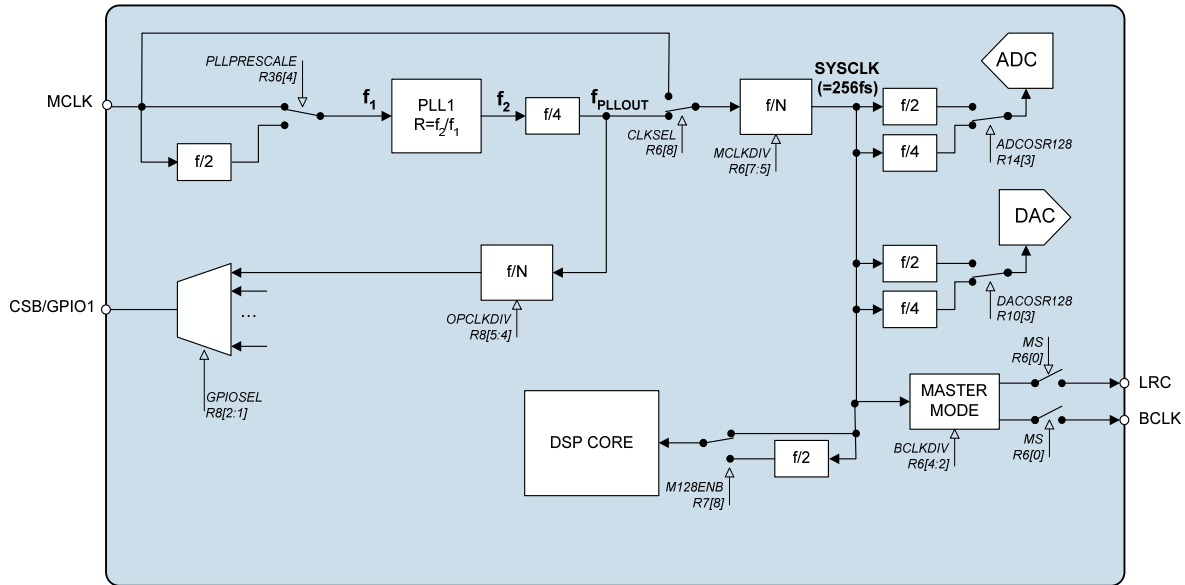


Figure 40 PLL and Clock Select Circuit

The PLL frequency ratio  $R = f_2/f_1$  (see Figure 40) can be set using the register bits PLLK and PLLN:

$$PLLN = \text{int } R$$

$$PLLK = \text{int } (2^{24} (R - PLLN))$$

**EXAMPLE:**

MCLK=12MHz, required clock = 12.288MHz.

R should be chosen to ensure  $5 < PLLN < 13$ . There is a fixed divide by 4 in the PLL and a selectable divide by N after the PLL which should be set to divide by 2 to meet this requirement.

Enabling the divide by 2 sets the required  $f_2 = 4 \times 2 \times 12.288\text{MHz} = 98.304\text{MHz}$ .

$$R = 98.304 / 12 = 8.192$$

$$PLLN = \text{int } R = 8$$

$$k = \text{int } ( 2^{24} \times (8.192 - 8) ) = 3221225 = 3126\text{E9h}$$

REGISTER ADDRESS	BIT	LABEL	DEFAULT	DESCRIPTION
R36 PLL N value	4	PLLPRESCALE	0	0 = MCLK input not divided (default) 1= Divide MCLK by 2 before input to PLL
	3:0	PLLN	1000	Integer (N) part of PLL input/output frequency ratio. Use values greater than 5 and less than 13.
R37 PLL K value 1	5:0	PLLK [23:18]	0Ch	Fractional (K) part of PLL1 input/output frequency ratio (treat as one 24-digit binary number).
R38 PLL K Value 2	8:0	PLLK [17:9]	093h	
R39 PLL K Value 3	8:0	PLLK [8:0]	0E9h	

Table 48 PLL Frequency Ratio Control

The PLL performs best when  $f_2$  is around 90MHz. Its stability peaks at N=8. Some example settings are shown below.

MCLK (MHz) (f1)	DESIRED OUTPUT (SYSCLK) (MHz)	f2 (MHz)	PRESCALE DIVIDE	POSTSCALE DIVIDE	R	N	K	N REGISTER R36[3:0]	K REGISTERS		
									R37	R38	R39
12	11.2889025	90.31122	1	2	7.525935	7h	86A3ACh	0111 (XX7h)	000100001 (021h)	101010001 (151h)	110101100 (1ACh)
12	12.288	98.304	1	2	8.192	8h	3126E8h	1000 (XX8h)	000001100 (00Ch)	010010011 (093h)	011101000 (0E8h)
13	11.29	90.3168	1	2	6.947446	6h	F28BD4h	0110 (XX6h)	000111100 (03Ch)	101000101 (145h)	111010100 (1D4h)
13	12.288	98.304	1	2	7.561846	7h	8FD525h	0111 (XX7h)	000100011 (023h)	111101010 (1Eah)	100100101 (125h)
14.4	11.29	90.3168	1	2	6.272	6h	45A1Cah	0110 (XX6h)	000010001 (011h)	011010000 (0D0h)	111001010 (1Cah)
14.4	12.288	98.304	1	2	6.826667	6h	D3A06Eh	0110 (XX6h)	000110100 (034h)	111010000 (1D0h)	001101110 (06Eh)
19.2	11.29	90.3168	2	2	9.408	9h	6872Afh	1001 (XX9h)	000011010 (01Ah)	000111001 (039h)	010101111 (0Afh)
19.2	12.288	98.304	2	2	10.24	Ah	3D70A3h	1010 (XXAh)	000001111 (00Fh)	010111000 (0B8h)	010100011 (0A3h)
19.68	11.29	90.3168	2	2	9.178537	9h	2DB492h	1001 (XX9h)	000001011 (00Bh)	011011010 (0Dah)	010010010 (092h)
19.68	12.288	98.304	2	2	9.990243	9h	FD809Fh	1001 (XX9h)	000111111 (03Fh)	011000000 (0C0h)	010011111 (09Fh)
19.8	11.29	90.3168	2	2	9.122909	9h	1F76F7h	1001 (XX9h)	000000111 (007h)	110111011 (1BBh)	011110111 (0F7h)
19.8	12.288	98.304	2	2	9.929697	9h	EE009Eh	1001 (XX9h)	000111011 (03Bh)	100000000 (100h)	010011110 (09Eh)
24	11.2889025	90.31122	2	2	7.525935	7h	86A3ACh	0111 (XX7h)	000100001 (021h)	101010001 (151h)	110101100 (1ACh)
24	12.288	98.304	2	2	8.192	8h	3126E8h	1000 (XX8h)	000001100 (00Ch)	010010011 (093h)	011101000 (0E8h)
26	11.29	90.3168	2	2	6.947446	6h	F28BD4h	0110 (XX6h)	000111100 (03Ch)	101000101 (145h)	111010100 (1D4h)
26	12.288	98.304	2	2	7.561846	7h	8FD525h	0111 (XX7h)	000100011 (023h)	111101010 (1Eah)	100100101 (125h)
27	11.29	90.3168	2	2	6.690133	6h	B0AC93h	0110 (XX6h)	000101100 (02Ch)	001010110 (056h)	010010011 (093h)
27	12.288	98.304	2	2	7.281778	7h	482296h	0111 (XX7h)	000010010 (012h)	000010001 (011h)	010010110 (096h)

Table 49 PLL Frequency Examples

## GENERAL PURPOSE INPUT/OUTPUT

The WM8758B has three dual purpose input/output pins.

- CSB/GPIO1: CSB / GPIO1 pin
- L2/GPIO2: Left channel line input / headphone detection input
- R2/GPIO3: Right channel line input / headphone detection input

The GPIO2 and GPIO3 functions are provided for use as jack detection inputs.

The GPIO1 and GPIO2 functions are provided for use as jack detection inputs or general purpose outputs.

The default configuration for the CSB/GPIO1 is to be an input.

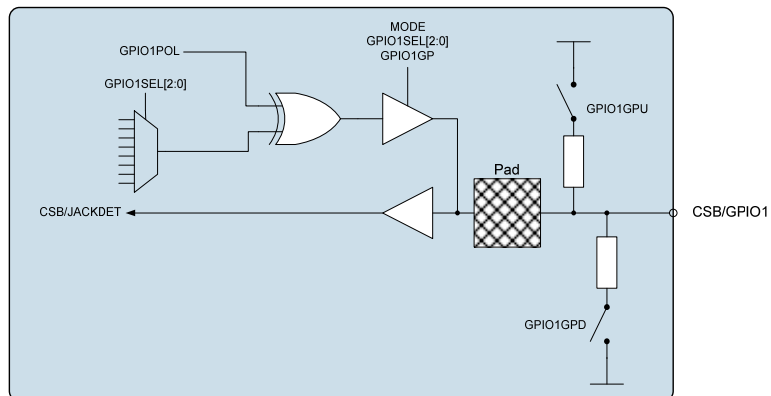
When setup as an input, the CSB/GPIO1 pin can either be used as CSB or for jack detection, depending on how the MODE pin is set.

Table 50 illustrates the functionality of the GPIO1 pin when used as a general purpose output.

REGISTER ADDRESS	BIT	LABEL	DEFAULT	DESCRIPTION
R8 GPIO Control	2:0	GPIO1SEL	000	CSB/GPIO1 pin function select: 000 = input (CSB / Jack detection: depending on MODE setting) 001 = reserved 010 = Temp ok 011 = Amute active 100 = PLL clk output 101 = PLL lock 110 = logic 0 111 = logic 1
	3	GPIO1POL	0	GPIO1 Polarity invert 0 = Non inverted 1 = Inverted
	5:4	OPCLKDIV	00	PLL Output clock division ratio 00 = divide by 1 01 = divide by 2 10 = divide by 3 11 = divide by 4
	6	GPIO1GPD	0	GPIO1 Internal pull-down enable: 0 = Internal pull-down disabled 1 = Internal pull-down enabled
	7	GPIO1GPU	0	GPIO1 Internal pull-up enable: 0 = Internal pull-up disabled 1 = Internal pull-up enabled
	8	GPIO1GP	0	GPIO1 Open drain enable 0 = Open drain disabled 1 = Open drain enabled

**Table 50 CSB/GPIO Control**

**Note:** If MODE is set to 3 wire mode, CSB/GPIO1 is used as CSB input irrespective of the GPIO1SEL[2:0] bits.



For further details of the jack detect operation see the OUTPUT SWITCHING section.

## OUTPUT SWITCHING (JACK DETECT)

When the device is operated using a 2-wire interface the CSB/GPIO1 pin can be used as a switch control input to automatically disable one set of outputs and enable another. The L2/GPIO2 and R2/GPIO3 pins can also be used for this purpose.

The GPIO pins have an internal de-bounce circuit when in this mode in order to prevent the output enables from toggling multiple times due to input glitches. This de-bounce circuit is clocked from a slow clock with period  $2^{21} \times \text{MCLK}$ .

Note that the GPIOPOL bit is not relevant for jack detection, it is the signal detected at the pin which is used.

The switching on/off of the outputs is fully configurable by the user. Each output, OUT1, OUT2, OUT3 and OUT4 has 2 associated enables. OUT1\_EN\_0, OUT2\_EN\_0, OUT3\_EN\_0 and OUT4\_EN\_0 are the output enable signals which are used if the selected jack detection pin is at logic 0 (after de-bounce). OUT1\_EN\_1, OUT2\_EN\_1, OUT3\_EN\_1 and OUT4\_EN\_1 are the output enable signals which are used if the selected jack detection pin is at logic 1 (after de-bounce).

Similar to the output enables, VMID can be output to OUT3. This VMID output can be configured to be on/off depending on the jack detection input polarity of VMID\_EN\_0 and VMID\_EN\_1.

The jack detection enables operate as follows:

All OUT\_EN signals have an AND function performed with their normal enable signals (in Table 38). When an output is normally enabled at per Table 38, the selected jack detection enable (controlled by selected jack detection pin polarity) is set 0, it will turn the output off. If the normal enable signal is already OFF (0), the jack detection signal will have no effect due to the AND function.

During jack detection if the user desires an output to be un-changed whether the jack is in or not, both the JD\_EN settings i.e. JD\_EN0 and JD\_EN1, should be set to 0000.

The VMID\_EN signal has an OR function performed with the normal VMID driver enable. If the VMID\_EN signal is to have no effect to normal functionality when jack detection is enabled, it should be set to 0 for all JD\_EN0 or JD\_EN1 settings.

If jack detection is not enabled (JD\_EN=0), the output enables default to all 1's, allowing the outputs to be controlled as normal via the normal output enables found in Table 38. Similarly the VMID\_EN signal defaults to 0 allowing the VMID driver to be controlled via the normal enable bit.



REGISTER ADDRESS	BIT	LABEL	DEFAULT	DESCRIPTION
R9 GPIO control	5:4	JD_SEL	00	Pin selected as jack detection input 00 = GPIO1 01 = GPIO2 10 = GPIO3 11 = Reserved
	6	JD_EN	0	Jack Detection Enable 0 = disabled 1 = enabled
	8:7	JD_VMID	00	[7] VMID_EN_0 [8] VMID_EN_1
R13	3:0	JD_EN0	0000	Output enables when selected jack detection input is logic 0. 0000 = OUT1_EN_0 0001 = OUT2_EN_0 0010 = OUT3_EN_0 0011 = OUT4_EN_0 0100-1111 = Reserved
	7:4	JD_EN1	0000	Output enables when selected jack detection input is logic 1 0000-0011 = Reserved 0100 = OUT1_EN_1 0101 = OUT2_EN_1 0110 = OUT3_EN_1 0111 = OUT4_EN_1 1000-1111 = Reserved

Table 51 Jack Detect Register Control Bits

## CONTROL INTERFACE

### SELECTION OF CONTROL MODE AND 2-WIRE MODE ADDRESS

The control interface can operate as either a 3-wire or 2-wire control interface. The MODE pin determines the 2 or 3 wire mode as shown in Table 52.

The WM8758B is controlled by writing to registers through a serial control interface. A control word consists of 16 bits. The first 7 bits (B15 to B9) are register address bits that select which control register is accessed. The remaining 9 bits (B8 to B0) are data bits, corresponding to the 9 data bits in each control register.

MODE	INTERFACE FORMAT
Low	2 wire
High	3 wire

Table 52 Control Interface Mode Selection

### 3-WIRE SERIAL CONTROL MODE

In 3-wire mode, every rising edge of SCLK clocks in one data bit from the SDIN pin. A rising edge on CSB/GPIO latches in a complete control word consisting of the last 16 bits.

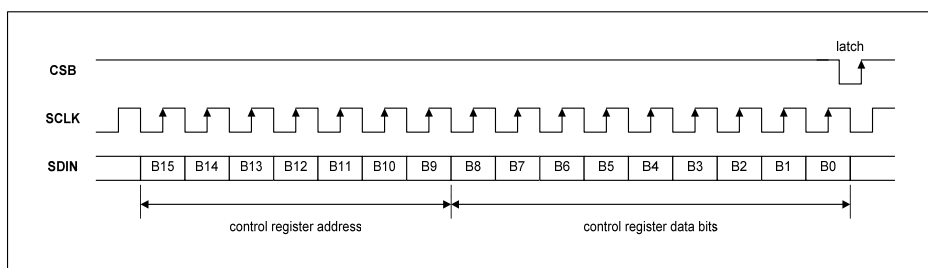


Figure 41 3-Wire Serial Control Interface

**2-WIRE SERIAL CONTROL MODE**

The WM8758B supports software control via a 2-wire serial bus. Many devices can be controlled by the same bus, and each device has a unique 7-bit device address (this is not the same as the 7-bit address of each register in the WM8758B).

The WM8758B operates as a slave device only. The controller indicates the start of data transfer with a high to low transition on SDIN while SCLK remains high. This indicates that a device address and data will follow. All devices on the 2-wire bus respond to the start condition and shift in the next eight bits on SDIN (7-bit address + Read/Write bit, MSB first). If the device address received matches the address of the WM8758B, the WM8758B responds by pulling SDIN low on the next clock pulse (ACK). If the address is not equalized or the R/W bit is '1' when operating in write only mode, the WM8758B returns to the idle condition and waits for a new start condition and valid address.

During a write, once the WM8758B has acknowledged a correct address, the controller sends the first byte of control data (B15 to B8, i.e. the WM8758B register address plus the first bit of register data). The WM8758B then acknowledges the first data byte by driving SDIN low for one clock cycle. The controller then sends the second byte of control data (B7 to B0, i.e. the remaining 8 bits of register data), and the WM8758B acknowledges again by pulling SDIN low.

Transfer is complete when there is a low to high transition on SDIN while SCLK is high. After a complete sequence the WM8758B returns to the idle state and waits for another start condition. If a start or stop condition is detected out of sequence at any point during data transfer (i.e. SDIN changes while SCLK is high), the control interface returns to the idle condition.

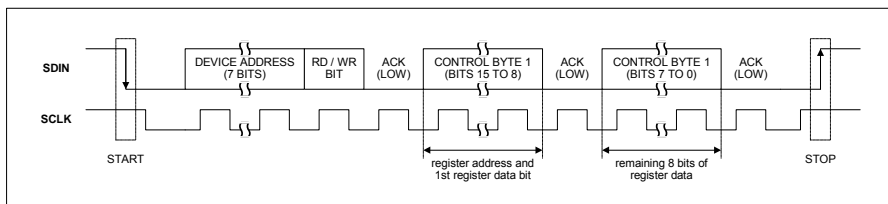


Figure 42 2-Wire Serial Control Interface

In 2-wire mode the WM8758B has a fixed device address, 0011010.

In 2-wire mode the CSB/GPIO1 pin controls the inversion of the HP\_COM and LINE\_COM register bits. When CSB/GPIO1 is set, these register bits are inverted (providing CSB/GPIO1 is not configured as a GPIO). See the section titled COMMON MODE DEFAULT for more details.

**RESETTING THE CHIP**

The WM8758B can be reset by performing a write of any value to the software reset register (address 0h). This will cause all register values to be reset to their default values. In addition to this there is a Power-On Reset (POR) circuit which ensures that the registers are initially set to default when the device is powered up.

## POWER SUPPLIES

The WM8758B requires four separate power supplies:

- AVDD1 and AGND1: Analogue supply, powers all internal analogue functions and output drivers LOUT1, ROUT1, OUT3 and OUT4. AVDD1 must be between 2.5V and 3.6V and has the most significant impact on overall power consumption (except for power consumed in the headphones). Higher AVDD will improve audio quality.
- AVDD2 and AGND2: Output driver supplies, power LOUT2 and ROUT2. AVDD2 must be between 2.5V and 3.6V. AVDD2 can be tied to AVDD1, but it requires separate layout and decoupling capacitors to curb harmonic distortion.
- DCVDD: Digital core supply, powers all digital functions except the audio and control interfaces. DCVDD must be between 1.71V and 3.6V, and has no effect on audio quality. The return path for DCVDD is DGND, which is shared with DBVDD.
- DBVDD must be between 1.71V and 3.6V. DBVDD return path is through DGND.

It is possible to use the same supply voltage for all four supplies. However, digital and analogue supplies should be routed and decoupled separately on the PCB to keep digital switching noise out of the analogue signal paths.

## POWER MANAGEMENT

### SAVING POWER BY REDUCING OVERSAMPLING RATE

The default mode of operation of the ADC and DAC digital filters is in 64x oversampling mode. Under the control of ADCOSR128 the oversampling rate may be doubled. 64x oversampling results in a slight decrease in noise performance compared to 128x but lowers the power consumption of the device.

REGISTER ADDRESS	BIT	LABEL	DEFAULT	DESCRIPTION
R14 ADC control	3	ADCOSR128	0	ADC oversample rate select 0 = 64x (lowest power) 1 = 128x (best SNR)

Table 53 ADC Oversampling Rate Selection

### LOW POWER MODE

If only DAC or ADC functionality is required, the WM8758B can be put into a low power mode. In this mode, the DSP core runs at half of the normal rate, reducing digital power consumption of the core by half. For DAC low power only, 3D enhancement with 2-Band equalizer functionality is permitted, where only Band 1 (low shelf) and Band 5 (high shelf) can be used. For ADC low power, the equalizer and 3D cannot be used.

REGISTER ADDRESS	BIT	LABEL	DEFAULT	DESCRIPTION
R7 Additional Ctrl	8	M128ENB	0	0 = low power mode enabled 1 = low power mode disabled

Table 54 DSP Core Low Power Mode Control

There are 3 modes of low power operation, as detailed below. The device will not enter low power unless in one of these register configurations, regardless of M128ENB.

FUNCTION	REGISTER BITS	SETTING	DESCRIPTION
ADC low power	M128ENB	0	Either or both of ADCENL and ADCENR must be set (mono or stereo mode)
	ADCENL	1	
	ADCENR	1	
	DACENL	0	
	DACENR	0	
	EQ3DMODE	1 (DAC path)	
DAC low power	M128ENB	0	Either or both of DACENL and DACENR must be set (mono or stereo mode)
	ADCENL	0	
	ADCENR	0	
	DACENL	1	
	DACENR	1	
		EQ3DMODE = 0: EQ in ADC path EQ3DMODE = 1: EQ in DAC path	

Table 55 DSP Core Low Power Modes for ADC Only and DAC Only Modes

### VMID

The analogue equalizer will not operate unless VMID is enabled. The impedance of the VMID resistor string, together with the decoupling capacitor on the VMID pin will determine the startup time of the VMID circuit.

REGISTER ADDRESS	BIT	LABEL	DEFAULT	DESCRIPTION
R1 Power management 1	1:0	VMIDSEL	00	Reference string impedance to VMID pin (Determines startup time): 00 = off (250kΩ VMID to AGND1) 01 = 100kΩ 10 = 500kΩ 11 = 10kΩ (for fast startup)

Table 56 VMID Impedance Control

### BIASEN

The analogue amplifiers will not operate unless BIASEN is enabled.

REGISTER ADDRESS	BIT	LABEL	DEFAULT	DESCRIPTION
R1 Power management 1	3	BIASEN	0	Analogue amplifier bias control 0 = disabled 1 = enabled

Table 57 Analogue Bias Control

### HALFOPBIAS

HALFOPBIAS halves the bias current to the output drivers (OUT1, OUT2, OUT3). Setting HALFOPBIAS will reduce the quiescent current from AVDD by 0.5mA but will degrade the THD+N significantly.

REGISTER ADDRESS	BIT	LABEL	DEFAULT	DESCRIPTION
R61 Bias Control	0	HALFO PBIAS	0	HALFOPBIAS (Do not use) 0 = disabled 1 = enabled (Reduces AVDD current by 0.5mA)

Table 58 HALFOPBIAS Control

Wolfson's recommendation is: Do not use HALFOPBIAS

**POP MINIMISATION****POBCTRL**

WM8758B has two bias generators. A noisy bias derived from AVDD and a low noise bias derived from VMID. POBCTRL is used to switch between the two bias generators. During power up, the AVDD derived bias is available as soon as AVDD is applied; the VMID derived bias is available once the VMID node has charged up.

**VMIDTOG**

Fast VMID discharge is enabled using VMIDTOG bit. Setting to 1 opens a low impedance discharge path from VMID to GND. This function can be used during power down to reduce the discharge time of the VMID decoupling capacitor. Must be set to 0 for normal operation.

REGISTER ADDRESS	BIT	LABEL	DEFAULT	DESCRIPTION
R42 OUT4 to ADC	2	POB CTRL	0	POBCTRL (Use during power Up. Reset when VMID bias is stable) 0 = Bias derived from VMID 1 = Bias derived from AVDD
	4	VMID TOG	0	Fast VMID discharge 0 = normal operation 1 = enabled (used during power-down sequence)

**Table 59 POBCTRL and VMIDTOG Control**

POBCTRL should be asserted during power up to minimize pops and then de-asserted at the end of the power up sequence to give best performance. Refer to Recommended Power Up/Down Sequence

## REGISTER MAP

ADDR B[15:9]		REGISTER NAME	B8	B7	B6	B5	B4	B3	B2	B1	B0	DEF'T VAL (HEX)	
DEC	HEX												
0	00	Software Reset	Software reset										
1	01	Power manage't 1	0	OUT4MIX EN	OUT3MIX EN	PLLEN	MICBEN	BIASEN	BUFIOEN	VMIDSEL		000	
2	02	Power manage't 2	ROUT1EN	LOUT1EN	SLEEP	BOOST ENR	BOOST ENL	INPGA ENR	INPPGA ENL	ADCENR	ADCENL	000	
3	03	Power manage't 3	OUT4EN	OUT3EN	LOUT2EN	ROUT2EN	0	RMIXEN	LMIXEN	DACENR	DACENL	000	
4	04	Audio Interface	BCP	LRP	WL		FMT		DLRSWAP	ALRSWAP	MONO	050	
5	05	Companding ctrl	0	0	0	WL8	DAC_COMP		ADC_COMP		LOOP BACK	000	
6	06	Clock Gen ctrl	CLKSEL	MCLKDIV			BCLKDIV			0	MS	140	
7	07	Additional ctrl	M128ENB	0	0	0	0	SR			SLOWCLK EN	000	
8	08	GPIO Stuff	GPIO1GP	GPIO1GPU	GPIO1GPD	OPCLKDIV		GPIO1POL	GPIO1SEL[2:0]			000	
9	09	Jack detect control	JD_VMID1	JD_VMID0	JD_EN	JD_SEL		0	0	0	0	000	
10	0A	DAC Control	0	0	SOFT MUTE	0	0	DACOSR 128	AMUTE	DACRPOL	DACLPOL	000	
11	0B	Left DAC digital Vol	DACVU	DACLVOL									OFF
12	0C	Right DAC dig'l Vol	DACVU	DACRVOL									OFF
13	0D	Jack Detect Control	0	JD_EN1				JD_EN0				000	
14	0E	ADC Control	HPFEN	HPFAPP	HPFCUT			ADCOSR 128	0	ADCRPOL	ADCLPOL	100	
15	0F	Left ADC Digital Vol	ADCVU	ADCLVOL									OFF
16	10	Right ADC Digital Vol	ADCVU	ADCRVOL									OFF
18	12	EQ1 – low shelf	EQ3DMODE	0	EQ1C			EQ1G				12C	
19	13	EQ2 – peak 1	EQ2BW	0	EQ2C			EQ2G				02C	
20	14	EQ3 – peak 2	EQ3BW	0	EQ3C			EQ3G				02C	
21	15	EQ4 – peak 3	EQ4BW	0	EQ4C			EQ4G				02C	
22	16	EQ5 – high shelf	0	0	EQ5C			EQ5G				02C	
24	18	DAC Limiter 1	LIMEN	LIMDCY				LIMATK				032	
25	19	DAC Limiter 2	0	0	LIMLVL				LIMBOOST				000
27	1B	Notch Filter 1	NFU	NFEN	NFA0[13:7]								000
28	1C	Notch Filter 2	NFU	0	NFA0[6:0]								000
29	1D	Notch Filter 3	NFU	0	NFA1[13:7]								000
30	1E	Notch Filter 4	NFU	0	NFA1[6:0]								000
32	20	ALC control 1	ALCSEL		0	ALCMAX			ALCMIN			038	
33	21	ALC control 2	0	ALCHLD				ALCLVL				00B	
34	22	ALC control 3	ALCMODE	ALCDCY								ALCATK	032
35	23	Noise Gate	0	0	0	0	0	NGEN	NGTH			000	
36	24	PLL N	0	0	0	0	PLLPRE SCALE	PLLN[3:0]				008	
37	25	PLL K 1	0	0	0	PLLK[23:18]						00C	
38	26	PLL K 2	PLLK[17:9]									093	
39	27	PLL K 3	PLLK[8:0]									0E9	
41	29	3D control	DEPTH3D									000	
42	2A	OUT4 to ADC	OUT4_2ADCVOL			OUT4_2 LNR	VMIDTOG	OUT2DEL	POBCTRL	DELEN	OUT1DEL	000	
43	2B	Beep control	BYPL2 RMIX	BYPR2 LMIX	0	0	0	0	DELEN2	0	0	000	

ADDR B[15:9]		REGISTER NAME	B8	B7	B6	B5	B4	B3	B2	B1	B0	DEF'T VAL (HEX)
DEC	HEX											
44	2C	Input ctrl	MICBVSEL	0	R2_2 INPPGA	RIN2 INPPGA	RIP2 INPPGA	0	L2_2 INPPGA	LIN2 INPPGA	LIP2 INPPGA	003
45	2D	Left INP PGA gain ctrl	INPGAVU	INPPGA ZCL	INPPGA MUTEL	INPPGAVOLL						010
46	2E	Right INP PGA gain ctrl	INPGAVU	INPPGA ZCR	INPPGA MUTER	INPPGAVOLR						010
47	2F	Left ADC Boost ctrl	PGA BOOSTL	0	L2_2BOOSTVOL			0	000			100
48	30	Right ADC Boost ctrl	PGA BOOSTR	0	R2_2BOOSTVOL			0	000			100
49	31	Output ctrl	HP_COM	LINE_COM	DACL2 RMIX	DACR2 LMIX	OUT4 ENDEL	OUT3 ENDEL	TSOP CTRL	TSDEN	VROI	002
50	32	Left mixer ctrl	0			0	BYPLMIXVOL			BYPL2 LMIX	DACL2 LMIX	001
51	33	Right mixer ctrl	0			0	BYPRMIXVOL			BYPR2 RMIX	DACR2 RMIX	001
52	34	LOUT1 (HP) volume ctrl	OUT1VU	LOUT1ZC	LOUT1 MUTE	LOUT1VOL						039
53	35	ROUT1 (HP) volume ctrl	OUT1VU	ROUT1ZC	ROUT1 MUTE	ROUT1VOL						039
54	36	LOUT2 (SPK) volume ctrl	OUT2VU	LOUT2ZC	LOUT2 MUTE	LOUT2VOL						039
55	37	ROUT2 (SPK) volume ctrl	OUT2VU	ROUT2ZC	ROUT2 MUTE	ROUT2VOL						039
56	38	OUT3 mixer ctrl	0	0	OUT3 MUTE	0	0	OUT4_ 2OUT3	BYPL2 OUT3	LMIX2 OUT3	LDAC2 OUT3	001
57	39	OUT4 (MONO) mixer ctrl	0	OUT 3_2OUT4	OUT4 MUTE	OUT4 ATTN	LMIX2 OUT4	LDAC2 OUT4	BYPR2 OUT4	RMIX2 OUT4	RDAC2 OUT4	001
61	3D	Bias Control	BIASCUT	0	HALF I_IPGA	0	BUFBIAS[1:0]		ADCBIAS[1:0]		HALFOP BIAS	000

Table 59 WM8758B Register Map

**DIGITAL FILTER CHARACTERISTICS**

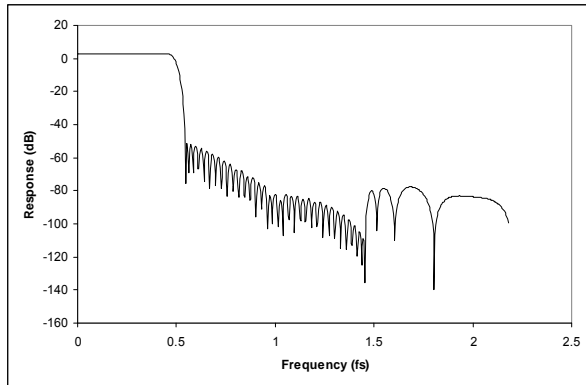
PARAMETER	TEST CONDITIONS	MIN	TYP	MAX	UNIT
<b>ADC Filter</b>					
Passband	+/- 0.025dB	0		0.454fs	
	-6dB		0.5fs		
Passband Ripple				+/- 0.025	dB
Stopband		0.546fs			
Stopband Attenuation	f > 0.546fs	-60			dB
Group Delay			21/fs		
<b>ADC High Pass Filter</b>					
High Pass Filter Corner Frequency	-3dB		3.7		Hz
	-0.5dB		10.4		
	-0.1dB		21.6		
<b>DAC Filter</b>					
Passband	+/- 0.035dB	0		0.454fs	
	-6dB		0.5fs		
Passband Ripple				+/-0.035	dB
Stopband		0.546fs			
Stopband Attenuation	f > 0.546fs	-55			dB
Group Delay			29/fs		

**Table 60 Digital Filter Characteristics****TERMINOLOGY**

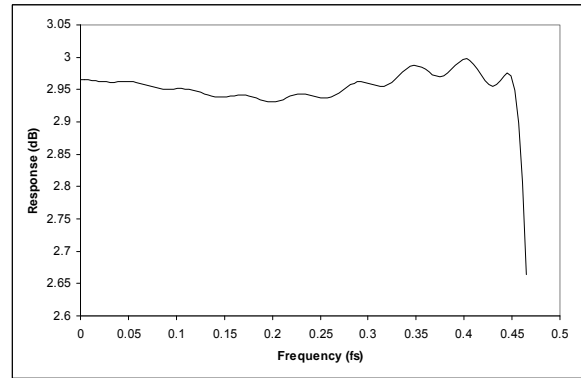
1. Stop Band Attenuation (dB) – the degree to which the frequency spectrum is attenuated (outside audio band)
2. Pass-band Ripple – any variation of the frequency response in the pass-band region



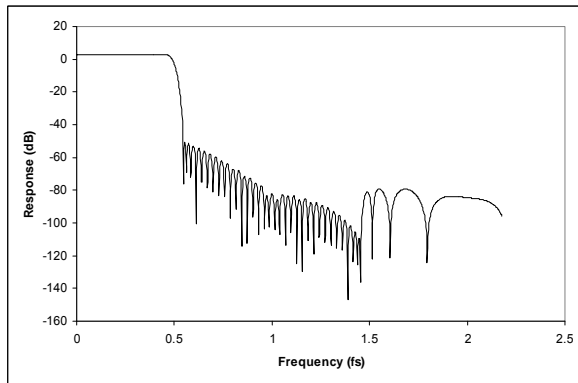
**DAC FILTER RESPONSES**



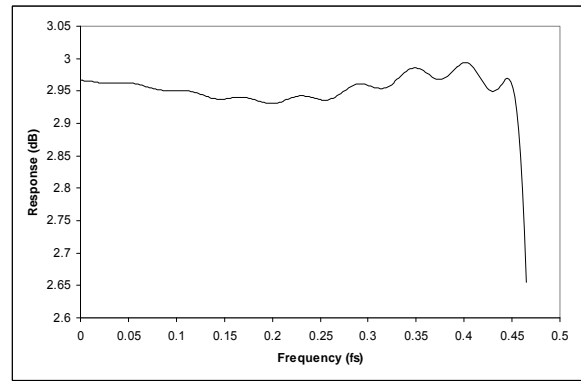
**Figure 43 DAC Digital Filter Frequency Response (128xOSR)**



**Figure 44 DAC Digital Filter Ripple (128xOSR)**

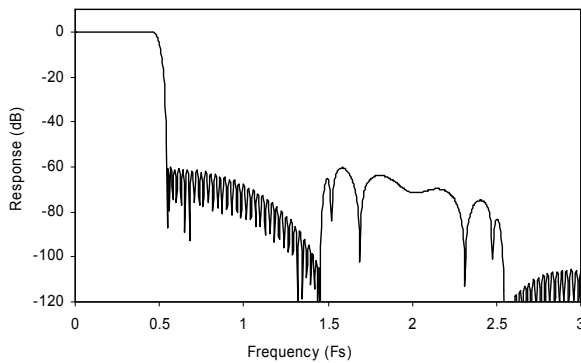


**Figure 45 DAC Digital Filter Frequency Response (64xOSR)**

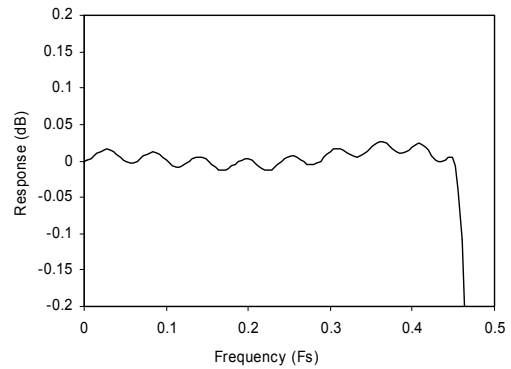


**Figure 46 DAC Digital Filter Ripple (64xOSR)**

**ADC FILTER RESPONSES**



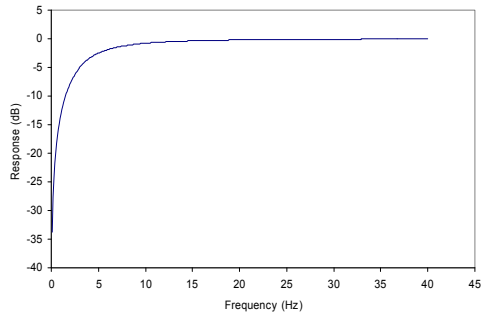
**Figure 47 ADC Digital Filter Frequency Response**



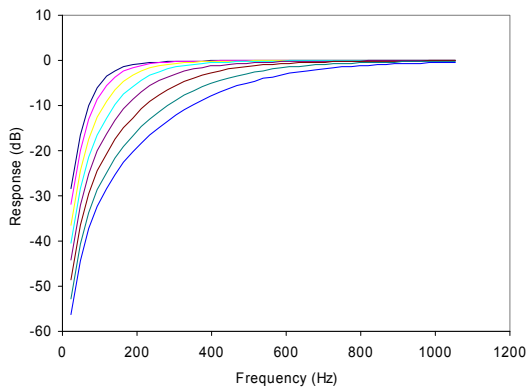
**Figure 48 ADC Digital Filter Ripple**

**HIGHPASS FILTER**

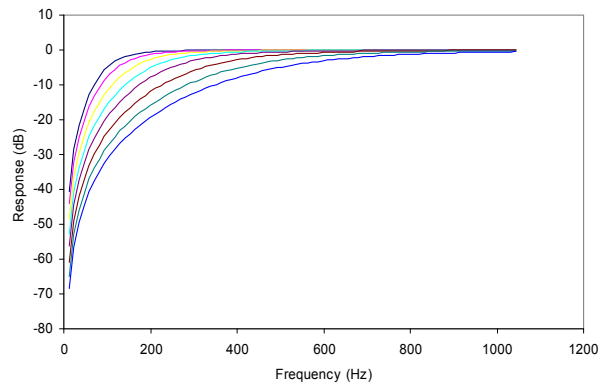
The WM8758B has a selectable digital highpass filter in the ADC filter path. This filter has two modes, audio and applications. In audio mode the filter is a 1<sup>st</sup> order IIR with a cut-off of around 3.7Hz. In applications mode the filter is a 2<sup>nd</sup> order high pass filter with a selectable cut-off frequency.



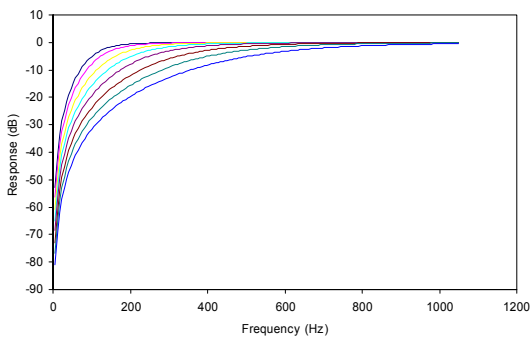
**Figure 49 ADC Highpass Filter Response, HPFAPP=0**



**Figure 50 ADC Highpass Filter Responses (48kHz), HPFAPP=1, all cut-off settings shown.**



**Figure 51 ADC Highpass Filter Responses (24kHz), HPFAPP=1, all cut-off settings shown.**



**Figure 52 ADC Highpass Filter Responses (12kHz), HPFAPP=1, all cut-off settings shown.**

### 5-BAND EQUALISER

The WM8758B has a 5-band equalizer which can be applied to either the ADC path or the DAC path. The plots from Figure 53 to Figure 66 show the frequency responses of each filter with a sampling frequency of 48kHz, firstly showing the different cut-off/centre frequencies with a gain of  $\pm 12\text{dB}$ , and secondly a sweep of the gain from  $-12\text{dB}$  to  $+12\text{dB}$  for the lowest cut-off/centre frequency of each filter.

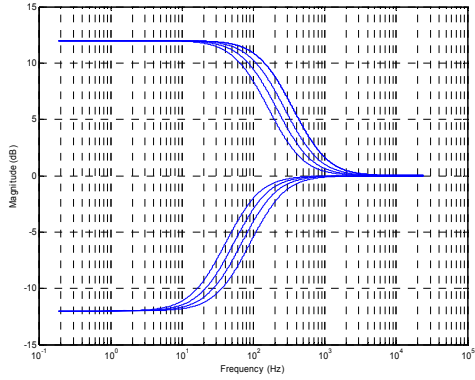


Figure 53 EQ Band 1 Low Frequency Shelf Filter Cut-offs

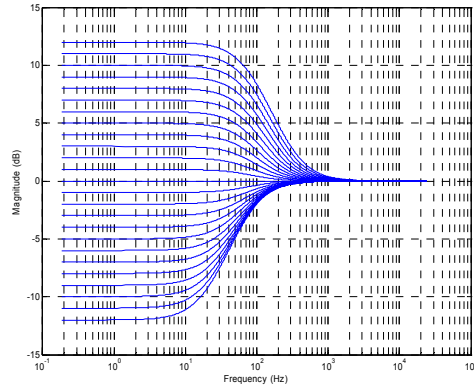


Figure 54 EQ Band 1 Gains for Lowest Cut-off Frequency

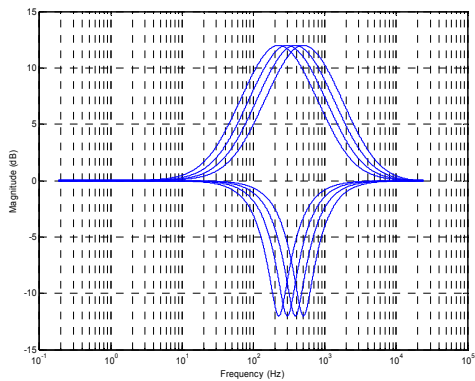


Figure 55 EQ Band 2 – Peak Filter Centre Frequencies, EQ2BW=0

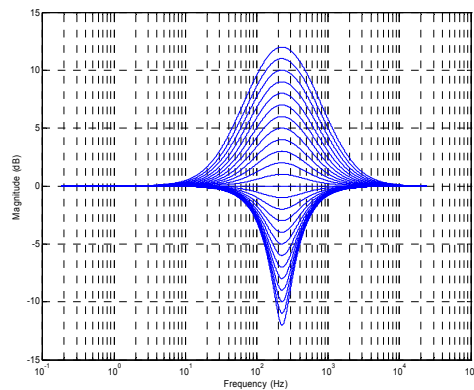


Figure 56 EQ Band 2 – Peak Filter Gains for Lowest Cut-off Frequency, EQ2BW=0

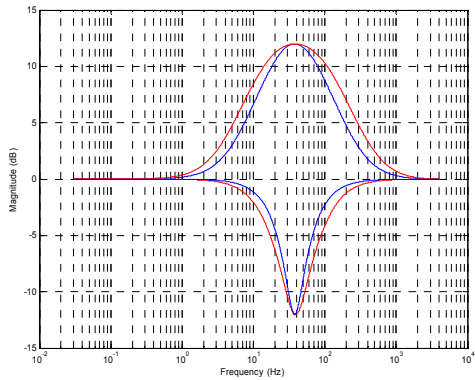


Figure 57 EQ Band 2 – EQ2BW=0, EQ2BW=1

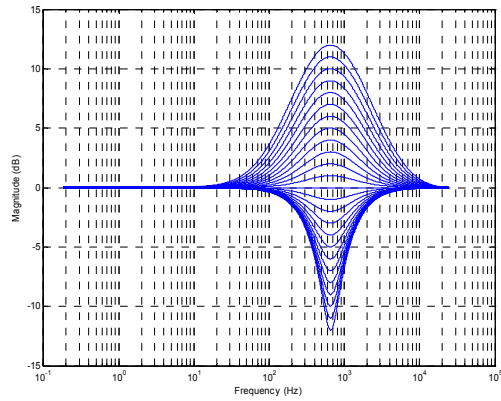
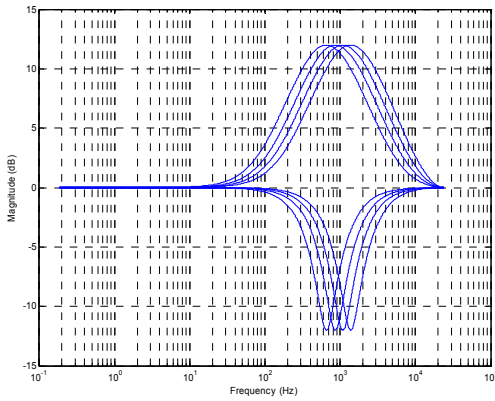


Figure 58 EQ Band 3 – Peak Filter Centre Frequencies, EQ3F Figure 59 EQ Band 3 – Peak Filter Gains for Lowest Cut-off Frequency, EQ3BW=0

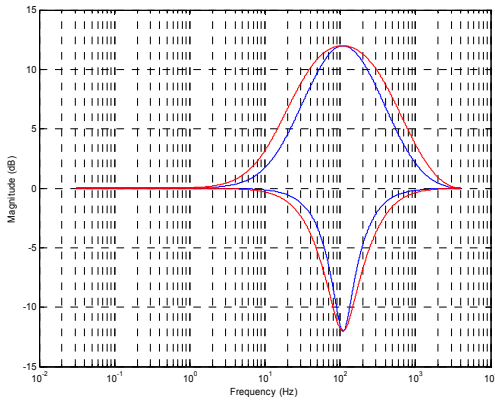


Figure 60 EQ Band 3 – EQ3BW=0, EQ3BW=1

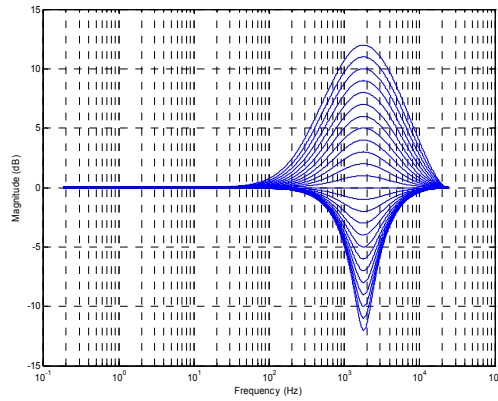
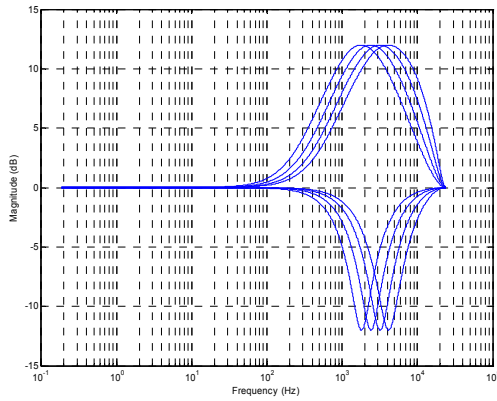


Figure 61 EQ Band 4 – Peak Filter Centre Frequencies, EQ3F Figure 62 EQ Band 4 – Peak Filter Gains for Lowest Cut-off Frequency, EQ4BW=0

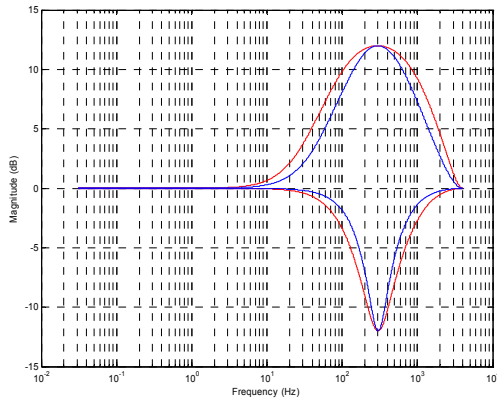


Figure 63 EQ Band 4 – EQ3BW=0, EQ3BW=1

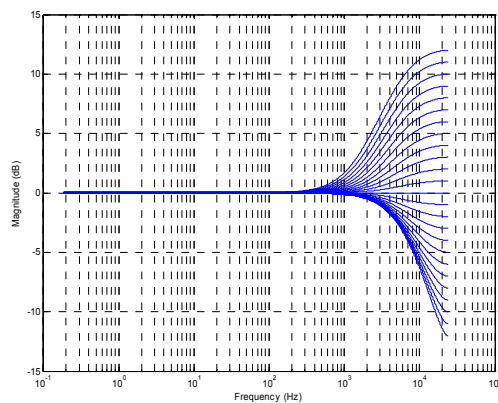
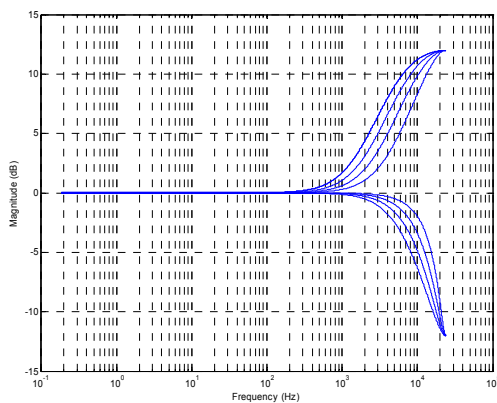


Figure 64 EQ Band 5 High Frequency Shelf Filter Cut-offs Figure 65 EQ Band 5 Gains for Lowest Cut-off Frequency

Figure 66 shows the result of having the gain set on more than one channel simultaneously. The blue traces show each band (lowest cut-off/centre frequency) with  $\pm 12\text{dB}$  gain. The red traces show the cumulative effect of all bands with  $+12\text{dB}$  gain and all bands  $-12\text{dB}$  gain, with EqxBW=0 for the peak filters.

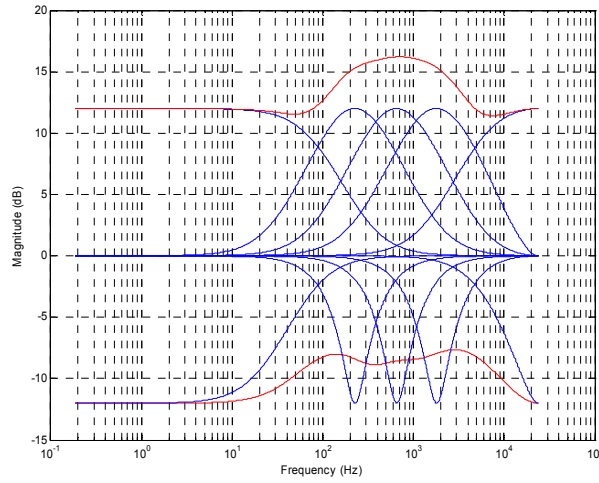


Figure 66 Cumulative Frequency Boost/Cut

## APPLICATIONS INFORMATION

### RECOMMENDED EXTERNAL COMPONENTS

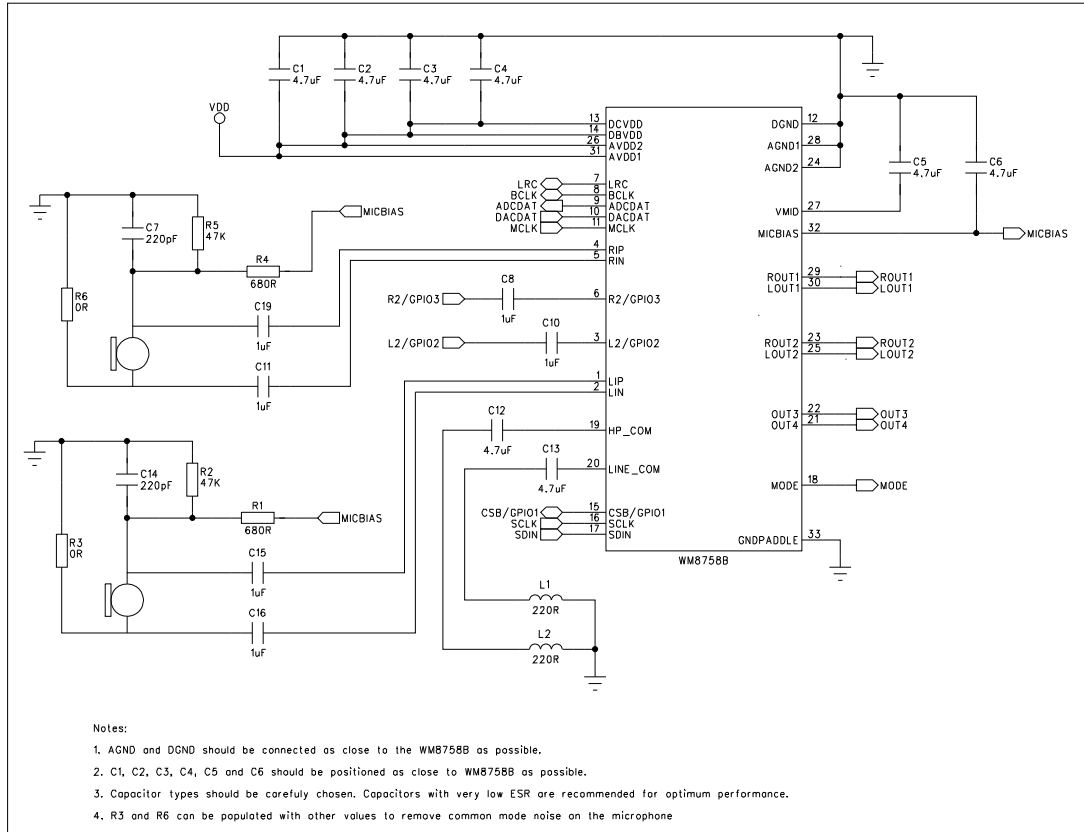
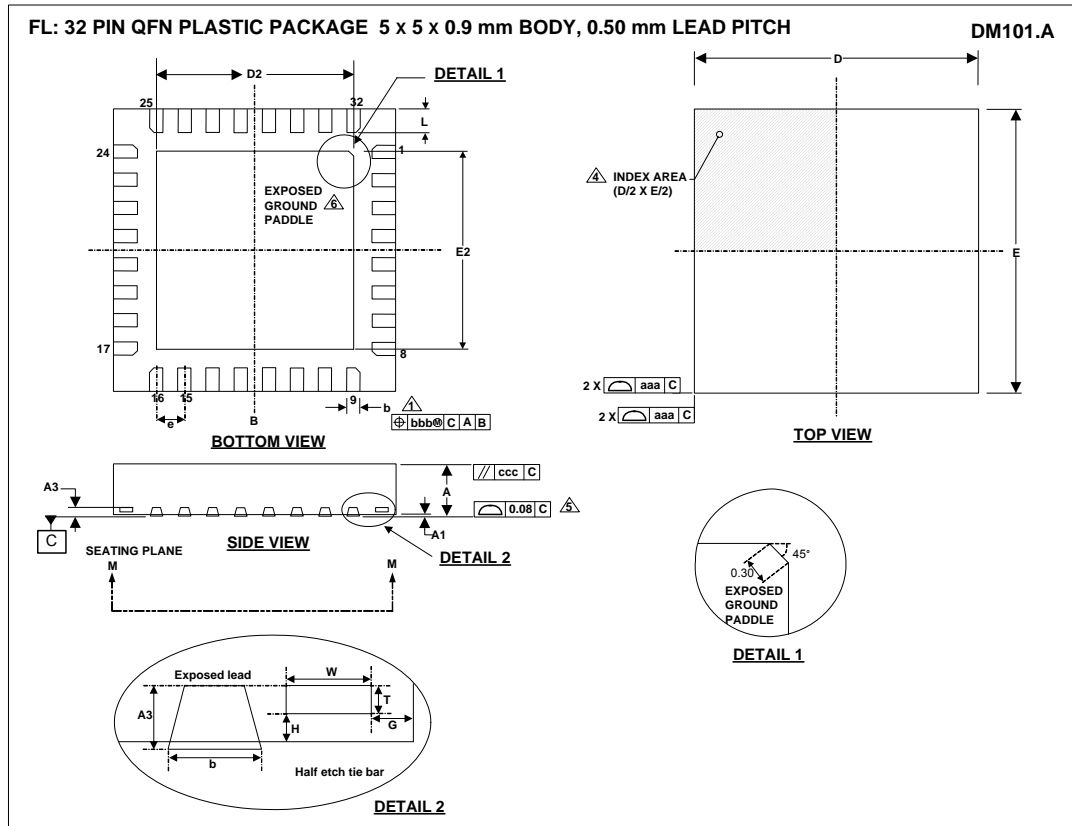


Figure 67 External Component Diagram

PACKAGE DIAGRAM



Symbols	Dimensions (mm)			NOTE
	MIN	NOM	MAX	
A	0.80	0.90	1.00	
A1	0	0.02	0.05	
A3		0.203 REF		
b	0.18	0.25	0.30	1
D		5.00 BSC		
D2	3.30	3.45	3.60	2
E		5.00 BSC		
E2	3.30	3.45	3.60	2
e		0.50 BSC		
G		0.20		
H		0.1		
L	0.30	0.40	0.50	
T		0.103		
W		0.15		
<b>Tolerances of Form and Position</b>				
aaa		0.15		
bbb		0.10		
ccc		0.10		
REF:	JEDEC, MO-220, VARIATION VHHD-5.			

- NOTES:
1. DIMENSION b APPLIES TO METALLIZED TERMINAL AND IS MEASURED BETWEEN 0.15 mm AND 0.30 mm FROM TERMINAL TIP.
  2. FALLS WITHIN JEDEC, MO-220, VARIATION VHHD-5.
  3. ALL DIMENSIONS ARE IN MILLIMETRES.
  4. THE TERMINAL #1 IDENTIFIER AND TERMINAL NUMBERING CONVENTION SHALL CONFORM TO JEDEC 95-1 SPP-002.
  5. COPLANARITY APPLIES TO THE EXPOSED HEAT SINK SLUG AS WELL AS THE TERMINALS.
  6. REFER TO APPLICATION NOTE WAN\_0118 FOR FURTHER INFORMATION REGARDING PCB FOOTPRINTS AND QFN PACKAGE SOLDERING.
  7. THIS DRAWING IS SUBJECT TO CHANGE WITHOUT NOTICE.



---

**IMPORTANT NOTICE**

Wolfson Microelectronics plc ("Wolfson") products and services are sold subject to Wolfson's terms and conditions of sale, delivery and payment supplied at the time of order acknowledgement.

Wolfson warrants performance of its products to the specifications in effect at the date of shipment. Wolfson reserves the right to make changes to its products and specifications or to discontinue any product or service without notice. Customers should therefore obtain the latest version of relevant information from Wolfson to verify that the information is current.

Testing and other quality control techniques are utilised to the extent Wolfson deems necessary to support its warranty. Specific testing of all parameters of each device is not necessarily performed unless required by law or regulation.

In order to minimise risks associated with customer applications, the customer must use adequate design and operating safeguards to minimise inherent or procedural hazards. Wolfson is not liable for applications assistance or customer product design. The customer is solely responsible for its selection and use of Wolfson products. Wolfson is not liable for such selection or use nor for use of any circuitry other than circuitry entirely embodied in a Wolfson product.

Wolfson's products are not intended for use in life support systems, appliances, nuclear systems or systems where malfunction can reasonably be expected to result in personal injury, death or severe property or environmental damage. Any use of products by the customer for such purposes is at the customer's own risk.

Wolfson does not grant any licence (express or implied) under any patent right, copyright, mask work right or other intellectual property right of Wolfson covering or relating to any combination, machine, or process in which its products or services might be or are used. Any provision or publication of any third party's products or services does not constitute Wolfson's approval, licence, warranty or endorsement thereof. Any third party trade marks contained in this document belong to the respective third party owner.

Reproduction of information from Wolfson datasheets is permissible only if reproduction is without alteration and is accompanied by all associated copyright, proprietary and other notices (including this notice) and conditions. Wolfson is not liable for any unauthorised alteration of such information or for any reliance placed thereon.

Any representations made, warranties given, and/or liabilities accepted by any person which differ from those contained in this datasheet or in Wolfson's standard terms and conditions of sale, delivery and payment are made, given and/or accepted at that person's own risk. Wolfson is not liable for any such representations, warranties or liabilities or for any reliance placed thereon by any person.

**ADDRESS:**

Wolfson Microelectronics plc  
Westfield House  
26 Westfield Road  
Edinburgh  
EH11 2QB  
United Kingdom

Tel :: +44 (0)131 272 7000

Fax :: +44 (0)131 272 7001

Email :: sales@wolfsonmicro.com

**REVISION HISTORY**

DATE	REV	ORIGINATOR	CHANGES
12/12/11	4.4	JMacD	Order codes changed from WM8758BGEFL/V and WM8758BGEFL/RV to WM8758CBGEFL/V and WM8758CBGEFL/RV to reflect change to copper wire bonding.
12/12/11	4.4	JMacD	Package diagram changed to DM101.A.