

Customer Information Sheet

DRAWING No.: M22-266XXXX

SHEET 2 OF 2

IF IN DOUBT - ASK

©

NOT TO SCALE

THIRD ANGLE PROJECTION

ALL DIMENSIONS IN mm

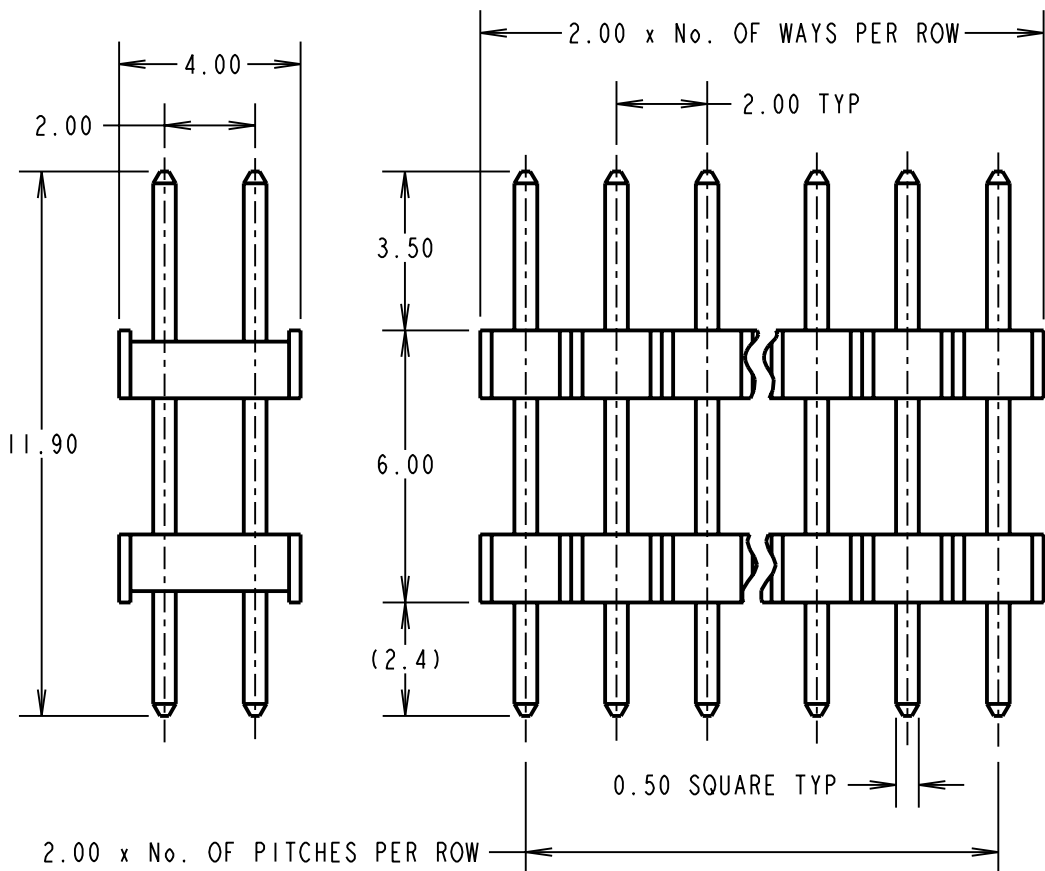

SPECIFICATIONS:

MATERIAL:
 MOULDING = NYLON 6T, UL94V-0, BLACK
 CONTACTS = PHOSPHOR BRONZE

FINISH:
 05 = GOLD
 46 = 100% TIN

ELECTRICAL:
 CURRENT RATING = 1A
 VOLTAGE PROOF = 650V AC
 CONTACT RESISTANCE:
 INITIAL = 15 mΩ MAX (GOLD), 20 mΩ MAX (TIN)
 AFTER CONDITIONING = 20 mΩ MAX (GOLD), 30 mΩ MAX (TIN)
 INSULATION RESISTANCE:
 INITIAL = 1,000 MΩ MIN
 AFTER CONDITIONING = 100 MΩ MIN

MECHANICAL:
 DURABILITY = 300 OPERATIONS (GOLD), 50 OPERATIONS (TIN)
 INSERTION FORCE = 2N MAX
 WITHDRAWAL FORCE = 0.3N MIN

ENVIRONMENTAL:
 TEMPERATURE RANGE = -55°C TO +105°C

PACKING:
 BAG

FOR COMPLETE SPECIFICATION, SEE
 COMPONENT SPECIFICATION C018XX (LATEST ISSUE)

ORDER CODE:

M22-266XXXX

NO. OF WAYS: _____
 02 TO 50

FINISH: _____
 05 = GOLD OVER NICKEL
 46 = 100% TIN OVER NICKEL

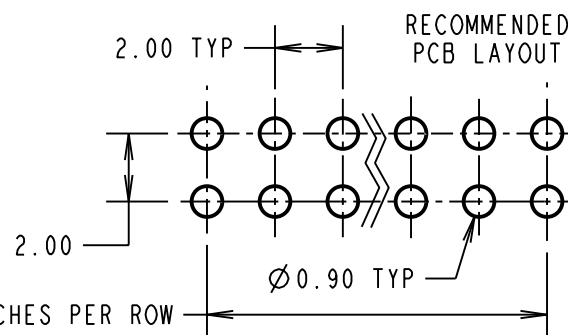

NOTES:
 1. ALL TOLERANCES ARE ±0.20 UNLESS OTHERWISE STATED.

2.00 x No. OF PITCHES PER ROW

SM	7	12.04.10	10731
NAME	ISS.	DATE	C/NOTE
APPROVED: S. MCCULLAGH			
CHECKED: R. ADDE			
DRAWN: W. J BOURNE			
CUSTOMER REF.:			
ASSEMBLY DRG:			

HARWIN

HARWIN USA TEL: 603 893 5376 FAX: 603 893 5396 mis@harwin.com	HARWIN Europe (UK) TEL: 023 9231 4545 FAX: 023 9231 4590 mis@harwin.co.uk	HARWIN Asia TEL: +65 6 779 4909 FAX: +65 6 779 3868 mis@harwin.com.sg
--	--	--

THIS DRAWING AND ANY INFORMATION OR DESCRIPTIVE MATTER SET OUT HEREON ARE CONFIDENTIAL AND COPYRIGHT PROPERTY OF THE HARWIN GROUP AND MUST NOT BE DISCLOSED, LOANED, COPIED OR USED FOR MANUFACTURING, TENDERING OR FOR ANY OTHER PURPOSE WITHOUT THEIR WRITTEN PERMISSION.

TOLERANCES
~~X. = ±1mm~~
~~X.X = ±0.25mm~~
~~X.XX = ±0.10mm~~
~~X.XXX = ±0.01mm~~
 ANGLES = ±5°
 UNLESS STATED

MATERIAL:
 SEE ABOVE

FINISH:
 SEE ABOVE

S/AREA:
 mm²

TITLE:
 2.00mm PITCH DIL EXT.
 PIN HEADER ASSEMBLY

DRAWING NUMBER:
M22-266XXXX

SHT
 2 OF
 2