

4X Ø 2.9 ∇ 13
M3.5X0.6 - 6H ∇ 12

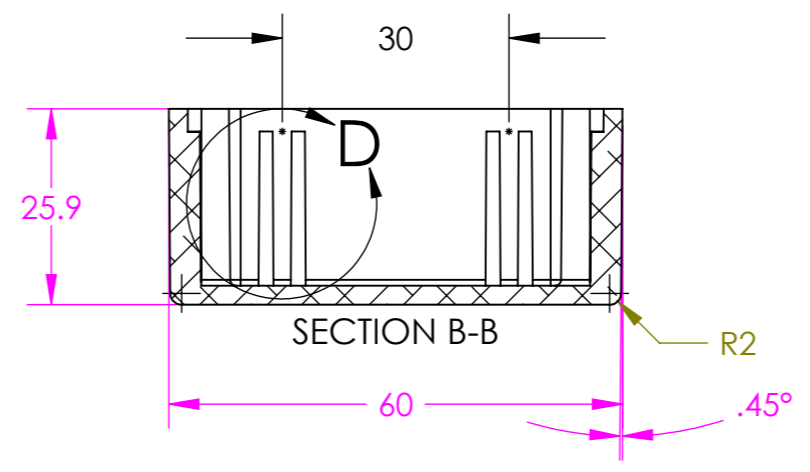

	GENERAL	PURPOSE	
SIZE	PLAIN	POWDER COATED	NYLON COATED
Q	459-0150	461-0150	462-0150
SEALED			
Q	460-0150	453-0150	454-0150

Tel No. +44(0)1724273200 Website www.dem-uk.com

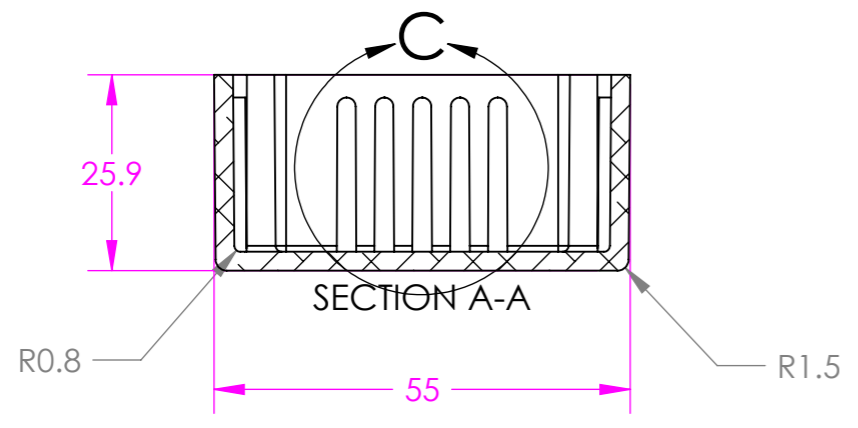
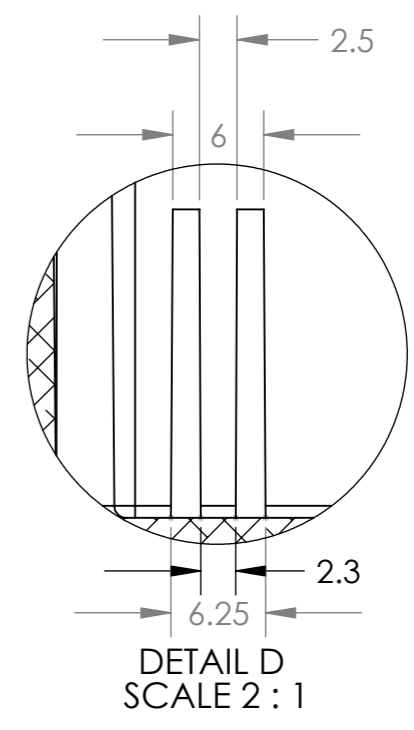
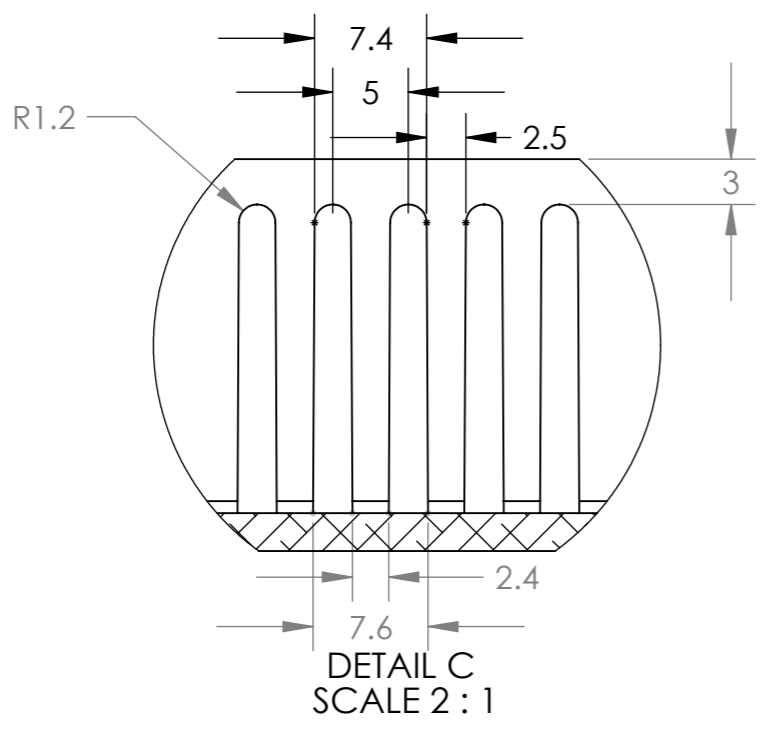
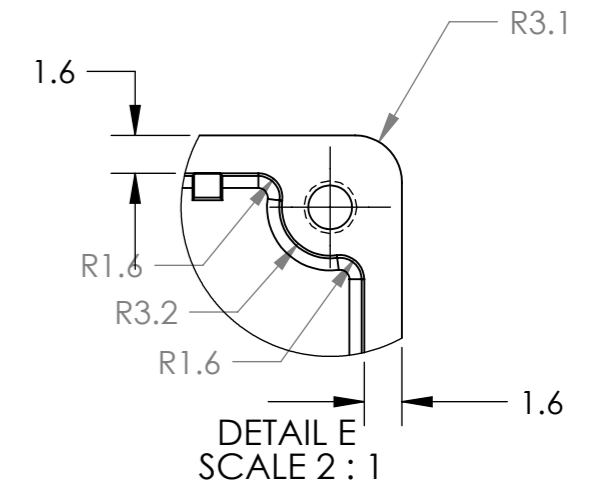
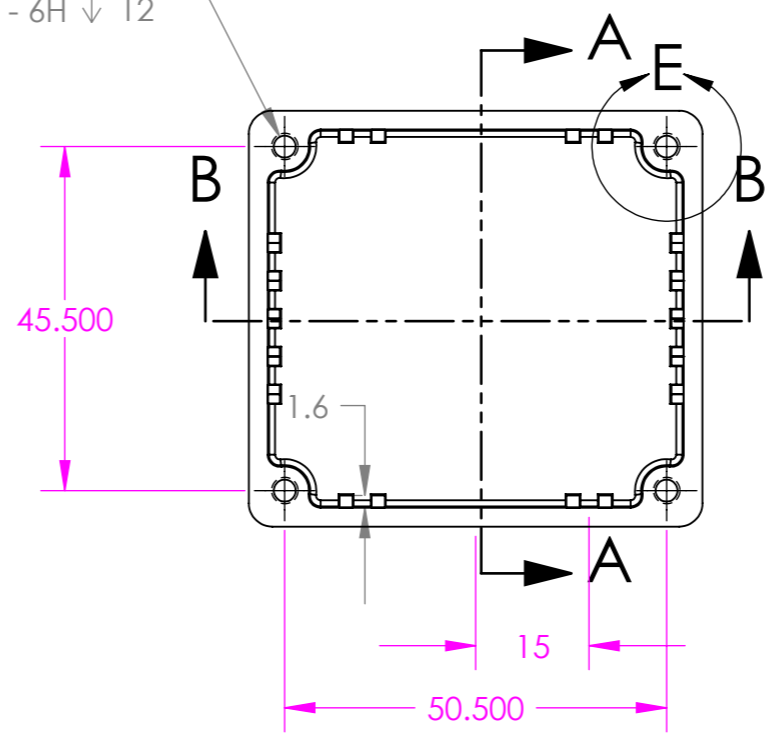

PROPRIETARY AND CONFIDENTIAL
THE INFORMATION CONTAINED IN THIS DRAWING IS THE SOLE PROPERTY OF ALPHA 3 MANUFACTURING.
ANY REPRODUCTION IN PART OR AS A WHOLE WITHOUT THE WRITTEN PERMISSION OF ALPHA 3 MANUFACTURING IS PROHIBITED.

DEM Manufacturing, Deltron Emcon House
Hargreaves Way, Sawcliffe Ind. Park,
Scunthorpe, North Lincolnshire, DN15 8RF, UK

UNLESS OTHERWISE SPECIFIED:
DIMENSIONS ARE IN MILLIMETRES
LINEAR TOLERANCE:
NO DECIMAL PLACES $\pm 0.5\text{mm}$
1 DECIMAL PLACE $\pm 0.25\text{mm}$
2 DECIMAL PLACES $\pm 0.125\text{mm}$
ANGULAR TOLERANCE: $\pm 1^\circ$

FINISH -
DEBURR AND BREAK SHARP EDGES
DRAWN BY B.SILLENCE
APPROVED BY B.SILLENCE
THIRD ANGLE PROJECTION
IF IN DOUBT ASK DO NOT SCALE DRAWING
MATERIAL Diecast Aluminium Alloy

TITLE **PROCUREMENT SPECIFICATION FOR 'Q' SIZE DIECAST BOX**
DRAWING NO. Q BOX
ISSUE 02
Release