

REV.	CNN	CNN DESCRIPTION	Date	Check in
01			13/04/2010	Shaun Barron

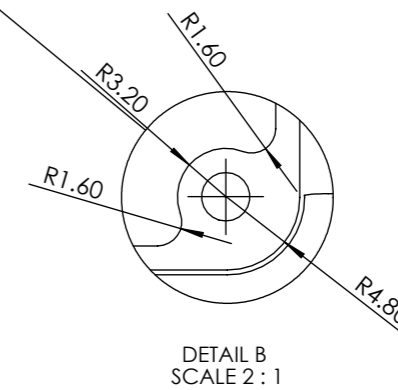

SIZE	PLAIN	FLANGED POWDER COATED	NYLON COATED
A	455-0010	457-0010	458-0010
SIZE	SEALED	FLANGED	
A	456-0010	463-0010	464-0010

Tel No.+44(0)1724273200 Website www.dem-uk.com

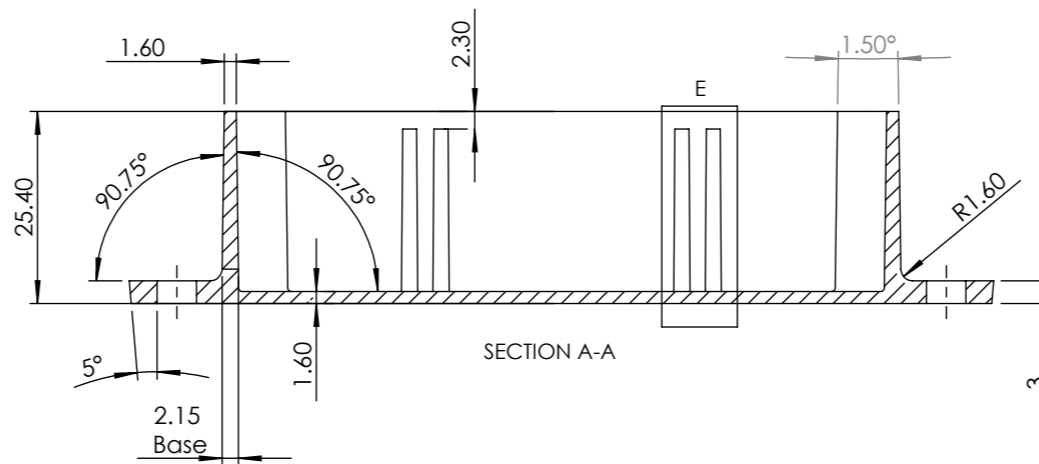
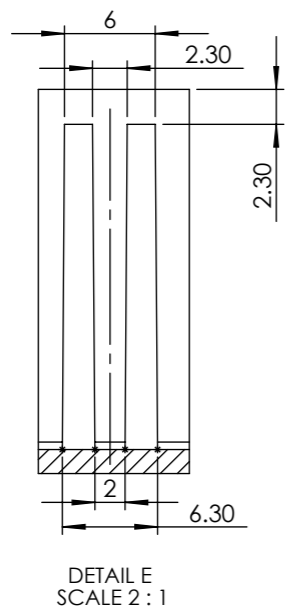
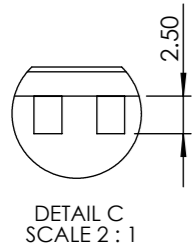
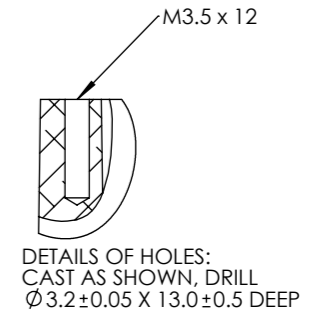
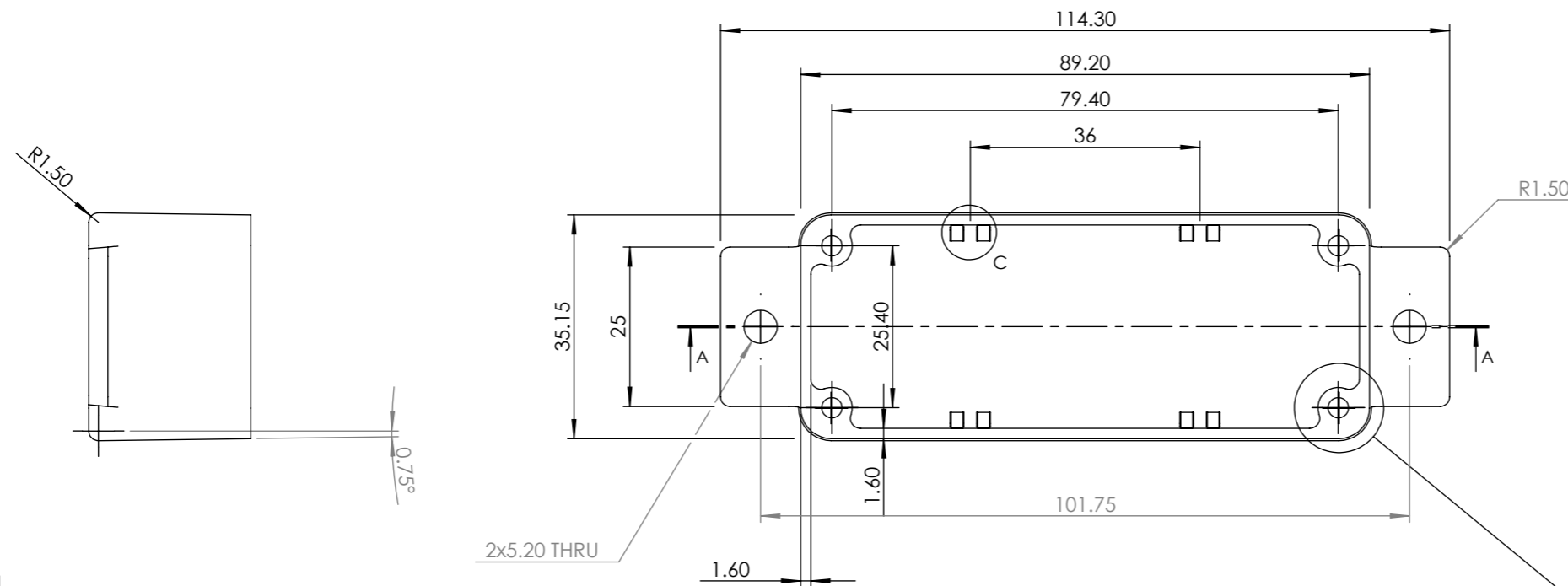

PROPRIETARY AND CONFIDENTIAL
THE INFORMATION CONTAINED IN THIS DRAWING IS THE SOLE PROPERTY OF ALPHA 3 MANUFACTURING.
ANY REPRODUCTION IN PART OR AS A WHOLE WITHOUT THE WRITTEN PERMISSION OF ALPHA 3 MANUFACTURING IS PROHIBITED.

DEM Manufacturing, Deltron Emcon House
Hargreaves Way, Sawcliffe Ind. Park,
Scunthorpe, North Lincolnshire, DN15 8RF, UK

UNLESS OTHERWISE SPECIFIED:
DIMENSIONS ARE IN MILLIMETRES
LINEAR TOLERANCE:
NO DECIMAL PLACES ±0.5mm
1 DECIMAL PLACE ±0.25mm
2 DECIMAL PLACES ±0.125mm
ANGULAR TOLERANCE: ±1°

FINISH .
DEBURR AND BREAK SHARP EDGES
DRAWN BY B.SILLENCE
APPROVED BY B.SILLENCE
THIRD ANGLE PROJECTION
IF IN DOUBT ASK DO NOT SCALE DRAWING
MATERIAL DieCast Aluminium Alloy

SCALE 1:1
A3

SHEET 1 OF 1
A BOX FLANGED

TITLE **PROCUREMENT SPECIFICATION FOR 'A' SIZE FLANGED BOX**
DRAWING NO. A BOX FLANGED
ISSUE 01
Release

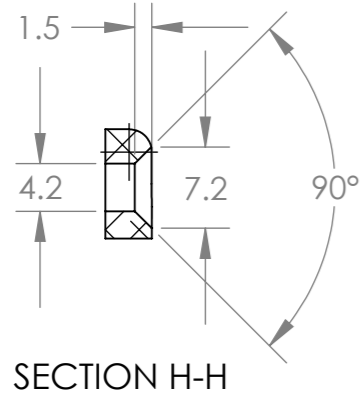
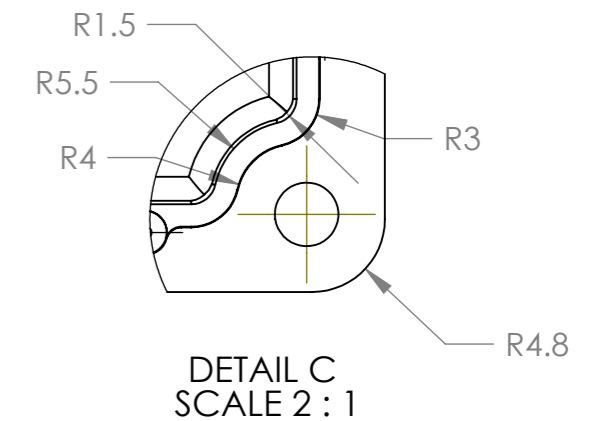
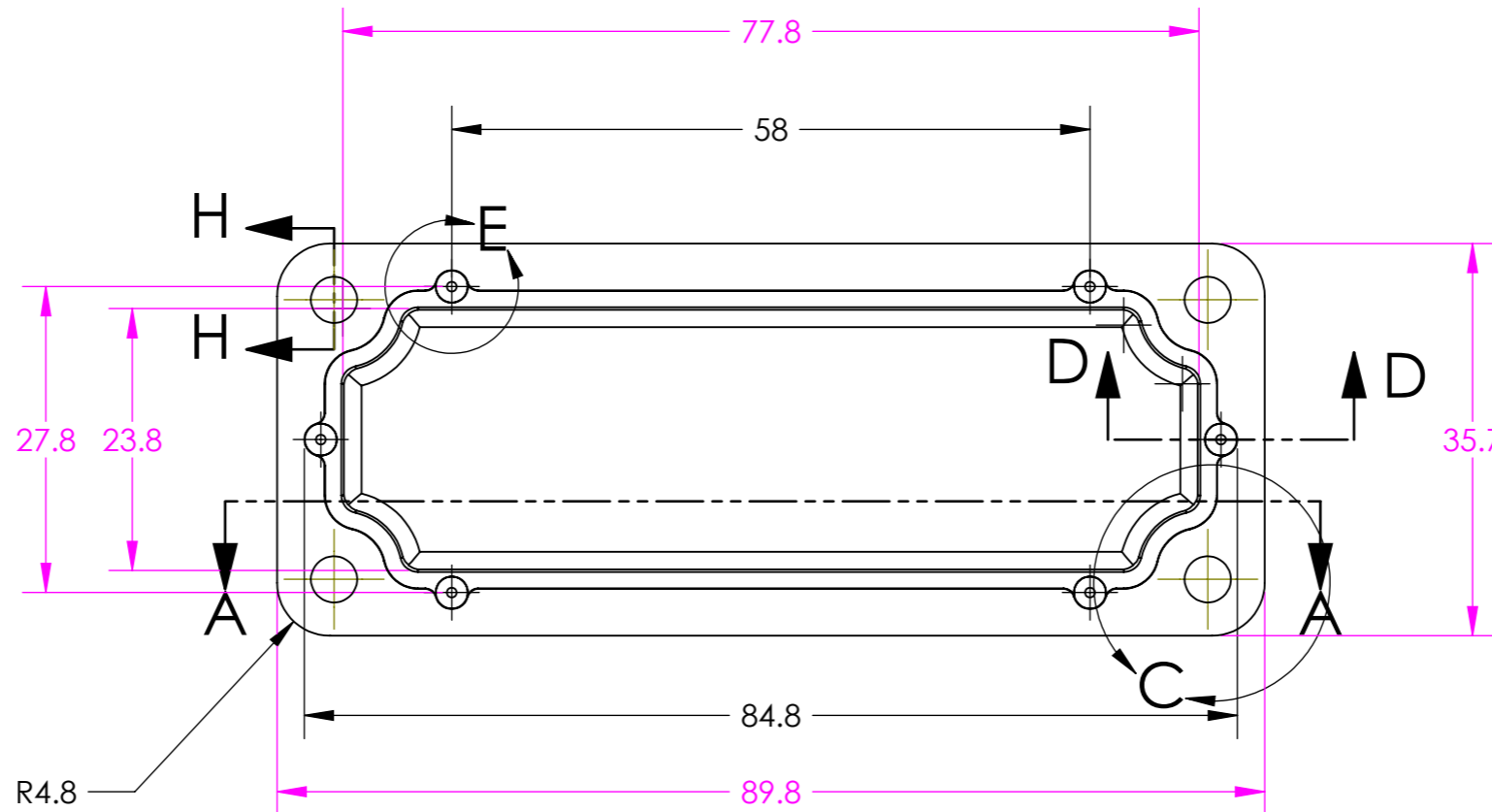
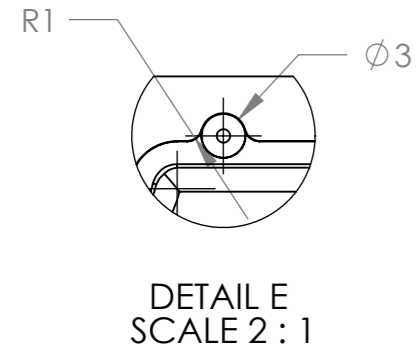
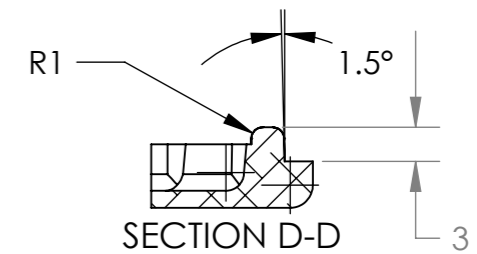
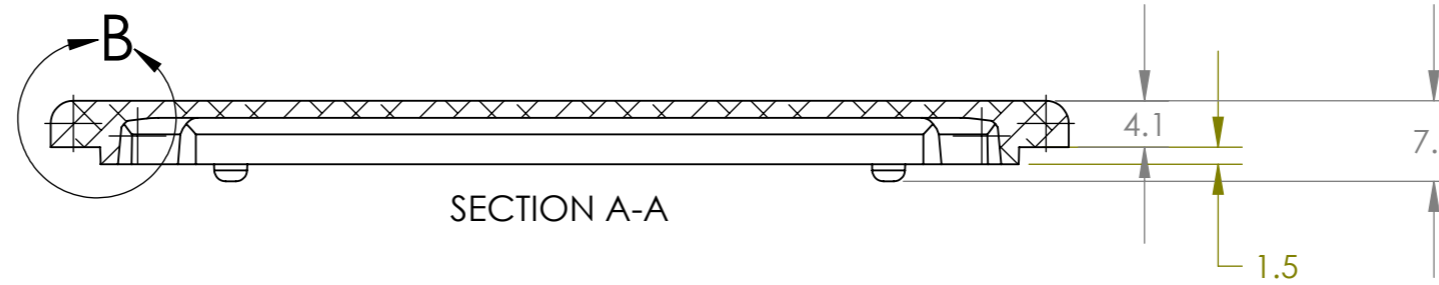
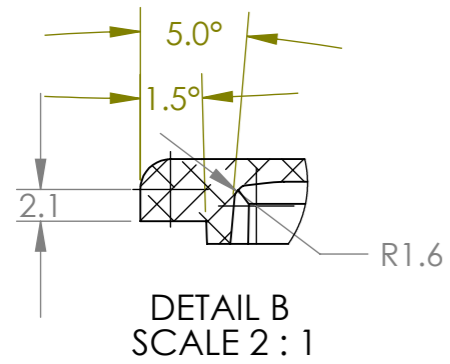

Tel No.+44(0)1724273200 Website www.dem-uk.com



PROPRIETARY AND CONFIDENTIAL
THE INFORMATION CONTAINED IN THIS DRAWING IS THE SOLE PROPERTY OF ALPHA 3 MANUFACTURING.
ANY REPRODUCTION IN PART OR AS A WHOLE WITHOUT THE WRITTEN PERMISSION OF ALPHA 3 MANUFACTURING IS PROHIBITED.

DEM Manufacturing, Deltron Emcon House
Hargreaves Way, Sawcliffe Ind. Park,
Scunthorpe, North Lincolnshire, DN15 8RF, UK

UNLESS OTHERWISE SPECIFIED:
DIMENSIONS ARE IN MILLIMETRES
LINEAR TOLERANCE:
NO DECIMAL PLACES ±0.5mm
1 DECIMAL PLACE ±0.25mm
2 DECIMAL PLACES ±0.125mm
ANGULAR TOLERANCE: ±1°

FINISH	DEBURR AND BREAK SHARP EDGES	DRAWN BY	B.SILLENC	TITLE	PROCUREMENT SPECIFICATION FOR 'A' SIZE BOX LID	
		APPROVED BY	B.SILLENC	DRAWING NO.	A LID	ISSUE 01
	IF IN DOUBT ASK DO NOT SCALE DRAWING	THIRD ANGLE PROJECTION	SHEET 1 OF 1			Release
MATERIAL	DieCast Aluminium Alloy		SCALE 1.5:1			
			A3			