

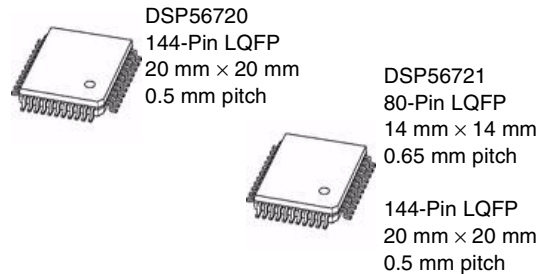

DSP56720/DSP56721

Symphony™ DSP56720/DSP56721 Multi-Core Audio Processors



The Symphony DSP56720/DSP56721 Multi-Core Audio Processors are part of the DSP5672x family of programmable CMOS DSPs, designed using multiple DSP56300 24-bit cores.

The DSP56720/DSP56721 devices are intended for automotive, consumer, and professional audio applications that require high performance for audio processing. In addition, the DSP56720 is ideally suited for applications that need the capability to expand memory off-chip or to interface to external parallel peripherals. Potential applications include A/V receivers, HD-DVD and Blu-Ray players, car audio/amplifiers, and professional recording equipment.

The DSP56720/DSP56721 devices excel at audio processing for automotive and consumer audio applications requiring high MIPs. Higher MIPs and memory requirements are driven by the new high-definition audio standards (Dolby Digital+, Dolby TrueHD, DTS-HD, for example) and the desire to process multiple audio streams.

In addition, DSP56720/DSP56721 devices are optimal for the professional audio market requiring audio recording, signal processing, and digital audio synthesis.

The DSP56720/DSP56721 processors provide a wealth of on-chip audio processing functions, via a plug and play software architecture system that supports audio decoding algorithms, various equalization algorithms, compression, signal generator, tone control, fade/balance, level meter/spectrum analyzer, among others. The DSP56720/DSP56721 devices also support various matrix decoders and sound field processing algorithms.

With two DSP56300 cores, a single DSP56720 or DSP56721 device can replace dual-DSP designs, saving costs while meeting high MIPs requirements. Legacy peripherals from the previous DSP5636x/7x families are included, as well as a variety of new modules. Included among the new modules are an Asynchronous Sample Rate Converter (ASRC), Inter-Core

Communication (ICC), an External Memory Controller (EMC) to support SDRAM, and a Sony/Philips Digital Interface (S/PDIF).

The DSP56720/DSP56721 offer 200 million instructions per second (MIPs) per core using an internal 200 MHz clock.

The DSP56720/DSP56721 are high density CMOS devices with 3.3 V inputs and outputs.

The DSP56720 device is slightly different than the DSP56721 device—the DSP56720 includes an external memory interface while the DSP56721 device does not. The DSP56720 block diagram is shown in [Figure 1](#); the DSP56721 block diagram is shown in [Figure 2](#).

Freescale reserves the right to change the detail specifications as may be required to permit improvements in the design of its products.

© Freescale Semiconductor, Inc., 2009. All rights reserved.

Table of Contents

1	Pin Assignments	4	2.12	Programming the SHI I ² C Serial Clock	26
1.1	Pinout for DSP56720 144-Pin Plastic LQFP Package	5	2.13	Enhanced Serial Audio Interface (ESAI) Timing	27
1.2	Pinout for DSP56721 80-Pin Plastic LQFP Package	6	2.14	Timer Timing	32
1.3	Pinout for DSP56721 144-Pin Plastic LQFP Package	7	2.15	GPIO Timing	32
1.4	Pin Multiplexing	7	2.16	JTAG Timing	33
2	Electrical Characteristics	8	2.17	Watchdog Timer Timing	35
2.1	Maximum Ratings	8	2.18	Host Data Interface (HDI24) Timing	35
2.2	Thermal Characteristics	9	2.19	S/PDIF Timing	42
2.3	Power Requirements	10	2.20	EMC Timing (DSP56720 Only)	43
2.5	DC Electrical Characteristics	12	3	Functional Description and Application Information	47
2.6	AC Electrical Characteristics	13	4	Ordering Information	48
2.7	Internal Clocks	13	5	Package Information	48
2.8	External Clock Operation	13	5.1	80-Pin Package Outline Drawing	49
2.9	Reset, Stop, Mode Select, and Interrupt Timing	15	5.2	144-Pin Package Outline Drawing	51
2.10	Serial Host Interface (SHI) SPI Protocol Timing	18	6	Product Documentation	53
2.11	Serial Host Interface (SHI) I ² C Protocol Timing	24	7	Revision History	53

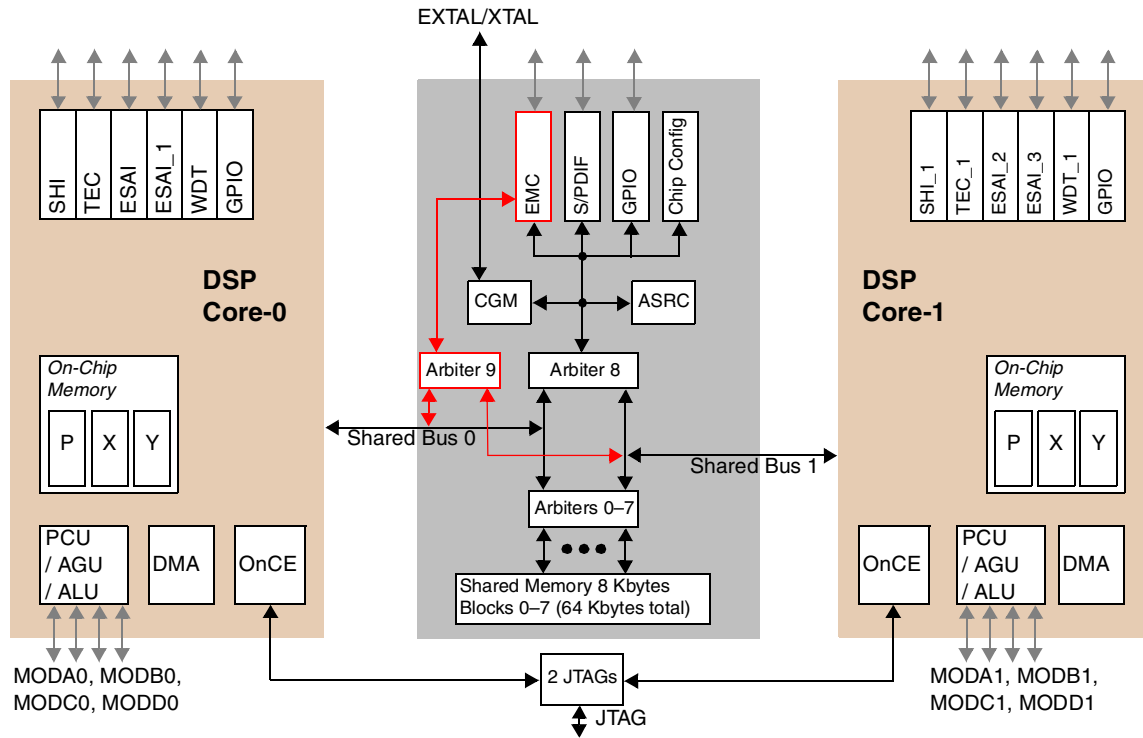

Figure 1. DSP56720 Block Diagram

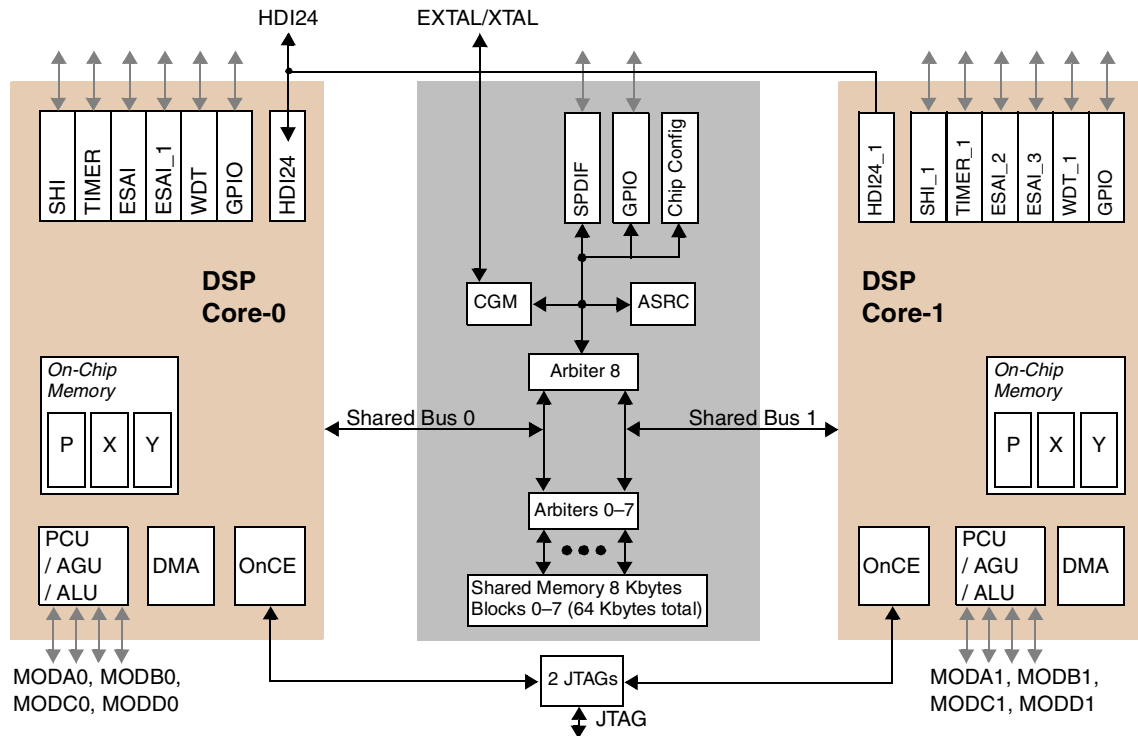

Figure 2. DSP56721 Block Diagram

1 Pin Assignments

DSP56720 devices are available in one package type; DSP56721 devices are available in two package types. For the pin assignments of a specific device in a specific package, refer to [Section 1.1, “Pinout for DSP56720 144-Pin Plastic LQFP Package,”](#) through [Section 1.3, “Pinout for DSP56721 144-Pin Plastic LQFP Package.”](#)

Table 1. Pin Assignments by Package

Device	Package	See
DSP56720	144-pin plastic LQFP	Figure 3 on page 5
DSP56721	80-pin plastic LQFP	Figure 4 on page 6
	144-pin plastic LQFP	Figure 5 on page 7

For more detailed information about signals, refer to the *Symphony™ DSP56720/DSP56721 Multi-Core Audio Processors Reference Manuall* (DSP56720RM).

1.1 Pinout for DSP56720 144-Pin Plastic LQFP Package

Figure 3 shows the pinout of the DSP56720 144-pin plastic LQFP package.

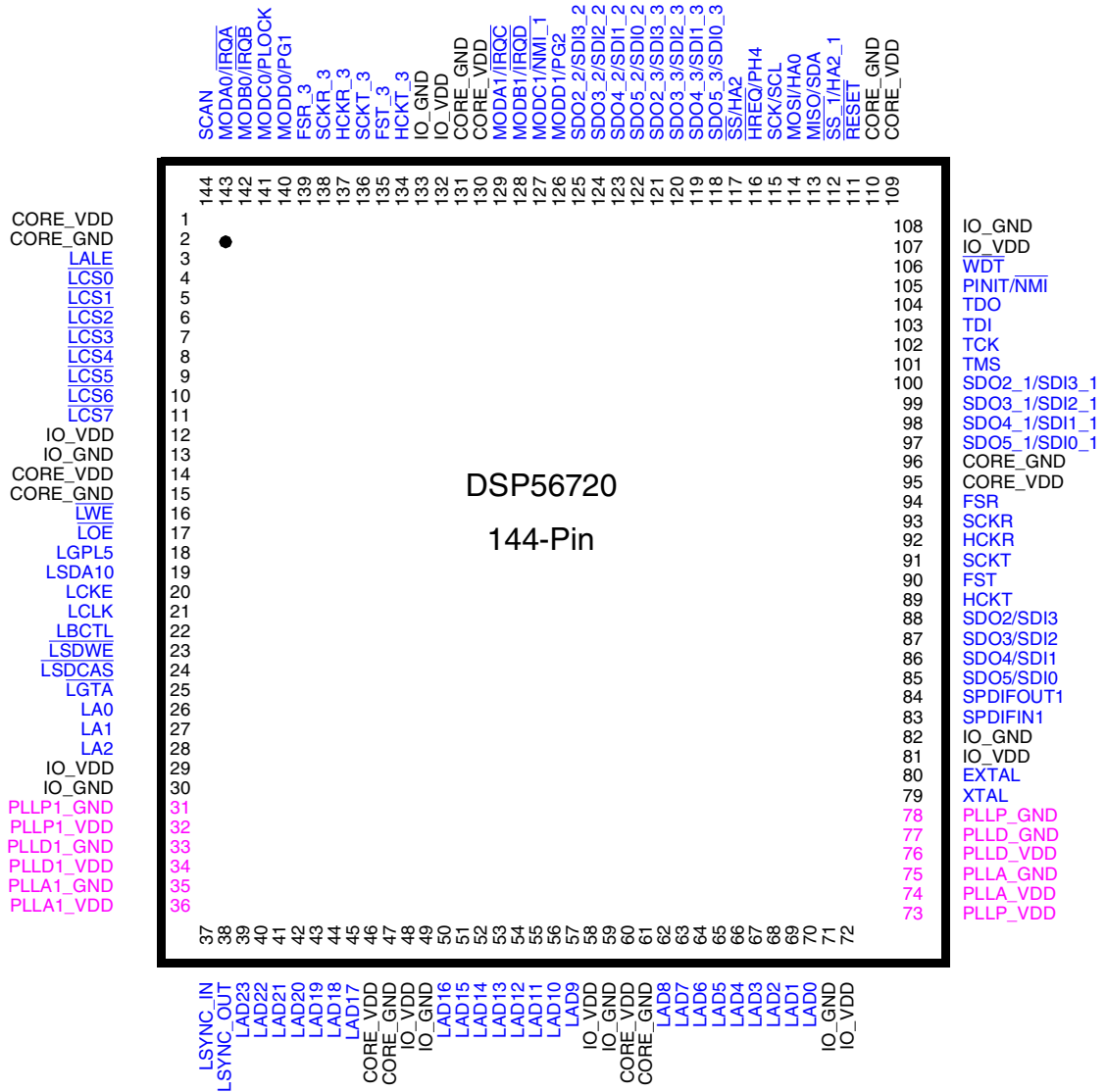

Figure 3. DSP56720 144-Pin Package Pinout

1.2 Pinout for DSP56721 80-Pin Plastic LQFP Package

Figure 4 shows the pinout of the DSP56721 80-pin plastic LQFP package.

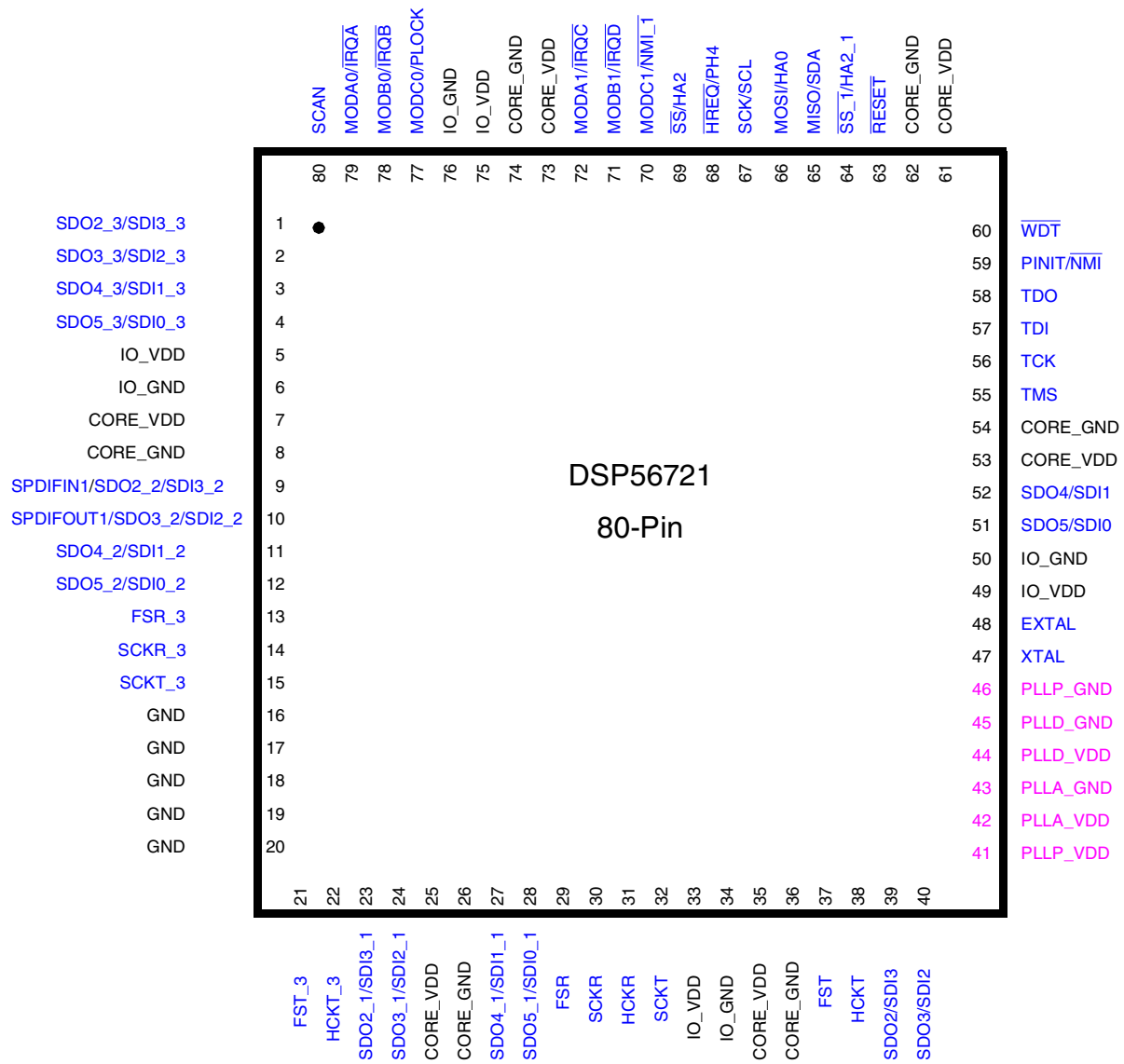

Figure 4. DSP56721 80-Pin Package

1.3 Pinout for DSP56721 144-Pin Plastic LQFP Package

Figure 5 shows the pinout of the DSP56721 144-pin plastic LQFP package.

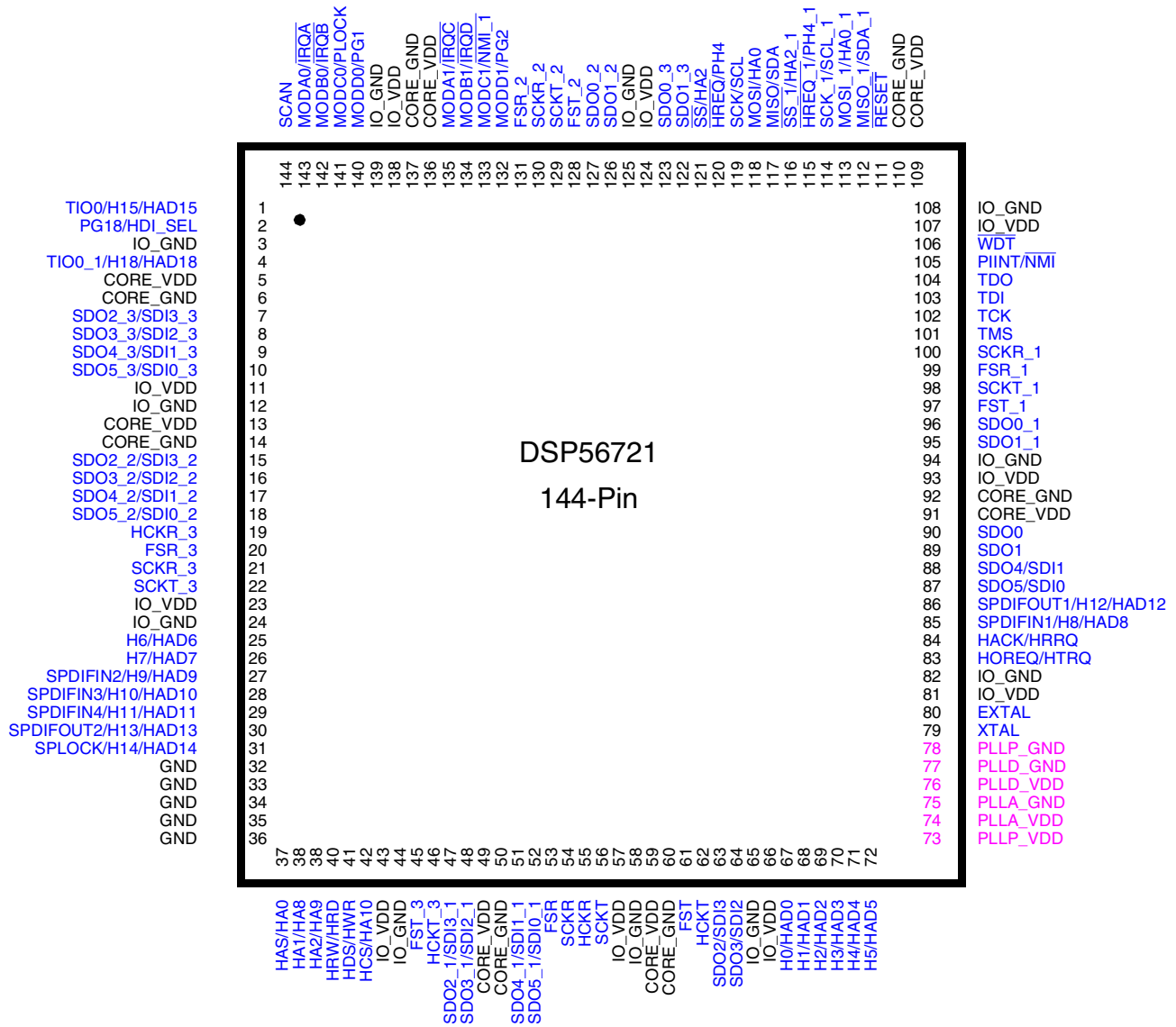

Figure 5. DSP56721 144-Pin Package Pinout

1.4 Pin Multiplexing

Many pins are multiplexed. For more about pin multiplexing, refer to the *Symphony™ DSP56720/DSP56721 Multi-Core Audio Processors Reference Manual* (DSP56720RM).

2 Electrical Characteristics

2.1 Maximum Ratings

Table 2 shows the maximum ratings.

CAUTION

This device contains circuitry protecting against damage due to high static voltage or electrical fields. However, normal precautions should be taken to avoid exceeding maximum voltage ratings. Reliability of operation is enhanced if unused inputs are pulled to an appropriate logic voltage level (for example, either GND or V_{DD}). The suggested value for a pull-up or pull-down resistor is 4.7 k Ω .

NOTE

In the calculation of timing requirements, adding a maximum value of one specification to a minimum value of another specification does not yield a reasonable sum. A maximum specification is calculated using a worst case variation of process parameter values in one direction. The minimum specification is calculated using the worst case for the same parameters in the opposite direction. Therefore, a “maximum” value for a specification will never occur in the same device that has a “minimum” value for another specification; adding a maximum to a minimum represents a condition that can never exist.

Table 2. Maximum Ratings

Rating ¹	Symbol	Value ^{1, 2}	Unit
Supply Voltage	V_{CORE_VDD} , V_{PLL_VDD}	-0.3 to + 1.26	V
	V_{PLL_VDD} , V_{IO_VDD} , V_{PLLA_VDD}	-0.3 to + 4.0	V
Maximum CORE_VDD power supply ramp time ³	T_r	10	ms
Input Voltage per pin excluding VDD and GND	V_{IN}	GND -0.3 to 5.5 V	V
Current drain per pin excluding V_{DD} and GND (Except for pads listed below)	I	12	mA
LSYNC_OUT	I_{sync_out}	16	mA
LCLK	I_{clk}	16	mA
LAL	I_{ale}	16	mA
TDO	I_{JTAG}	24	mA
Operating temperature range	T_J	-40 to +100	°C

Table 2. Maximum Ratings (Continued)

Rating ¹	Symbol	Value ^{1, 2}	Unit
Storage temperature	T _{STG}	-65 to +150	°C
ESD protected voltage (Human Body Model)	—	2000	V
ESD protected voltage (Charged Device)	—	500 750	V
<ul style="list-style-type: none"> • All pins • Corner pins 			

Note:

- GND = 0 V, T_J = -40° C to 100° C, CL = 50 pF
- Absolute maximum ratings are stress ratings only, and functional operation at the maximum is not guaranteed. Stress beyond the maximum rating may affect device reliability or cause permanent damage to the device.
- If the power supply ramp to full supply time is longer than 10 ms, the POR circuitry will not operate correctly, causing erroneous operation.

2.2 Thermal Characteristics

Table 3 provides the thermal characteristics for the device.

Table 3. Thermal Characteristics

Characteristic	Board Type	Symbol	LQFP Values	Unit
Natural Convection, Junction-to-ambient thermal resistance ^{1,2}	Single layer board (1s)	R _{θJA} or θ _{JA}	57 for 80 QFP 49 for 144 QFP	°C/W
	Four layer board (2s2p)		44 for 80 QFP 40 for 144 QFP	°C/W
Junction-to-case thermal resistance ³	—	R _{θJC} or θ _{JC}	10 for 80 QFP 9 for 144 QFP	°C/W

Notes:

- Junction temperature is a function of die size, on-chip power dissipation, package thermal resistance, mounting site (board) temperature, ambient temperature, air flow, power dissipation of other components on the board, and board thermal resistance.
- Per SEMI G38-87 and JEDEC JESD51-2 with the single layer board horizontal.
- Thermal resistance between the die and the case top surface as measured by the cold plate method (MIL SPEC-883 Method 1012.1).

The average chip-junction temperature (T_J) in °C can be obtained from:

$$T_J = T_A + (P_D \times \theta_{JMA})$$

Where:

- T_A = Ambient Temperature, °C
- θ_{JMA} = Package Thermal Resistance, Junction-to-Ambient, °C/W
- P_D = P_{INT} + P_{I/O}
- P_{INT} = I_{DD} × V_{DD}, Watts – Chip Internal Power
- P_{I/O} = Power Dissipation on Input and Output Pins—User Determined

For most applications, P_{I/O} < P_{INT} and can be ignored. P_D can be calculated using the worst-case conditions of 1.1 V and 780 mA. See Table 4 for more information.

To find T_J at 100° C, using the worst-case conditions and a four-layer board:

$$P_D = 1.1 \text{ V} \times 625 \text{ mA}$$

$$= 0.6875 \text{ W}$$

$$T_J = 70 + (0.6875 \times 40)$$

$$= 97.5^\circ \text{ C}$$

2.3 Power Requirements

To prevent high current conditions due to possible improper sequencing of the power supplies, use an external Schottky diode as shown in [Figure 6](#), connected between the DSP56720/DSP56721 IO_VDD and Core_VDD power pins.

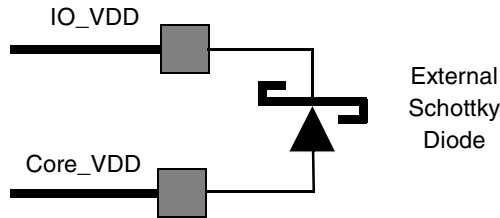

Figure 6. Prevent High Current Conditions by Using External Schottky Diode

If an external Schottky diode is not used (to prevent a high current condition at power-up), then IO_VDD must be applied ahead of Core_VDD, as shown in [Figure 7](#).

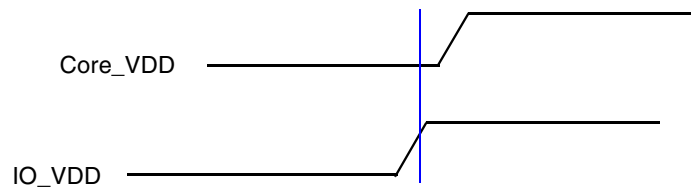

Figure 7. Prevent High Current Conditions by Applying IO_VDD Before Core_VDD

For correct operation of the internal power-on reset logic, the Core_VDD ramp rate (T_r) to full supply must be less than 10 ms, as shown in [Figure 8](#).

There are no power down requirement for the digital 1.0 V (CORE) and 3.3 V (IO). For the analog PLL power, the digital (IO) 3.3 V must be power up before the analog 3.3 V power. Similarly, for power down the digital (IO) 3.3 V must be power down after the analog power 3.3 V. This requirement is for avoiding possible leakage.

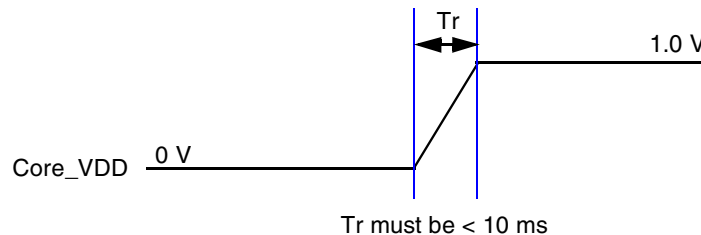

Figure 8. Ensure Correct Operation of Power-On Reset with Fast Ramp of Core_VDD

2.4 Power Consumption Considerations

Power dissipation is a key issue in portable DSP applications. Some of the factors which affect current consumption are described in this section. Most of the current consumed by CMOS devices is alternating current (ac), which is charging and discharging the capacitances of the pins and internal nodes.

Current consumption is described by the following formula:

$$I = C \times V \times f \quad \text{Eqn. 1}$$

where C=node/pin capacitance
V=voltage swing
f=frequency of node/pin toggle

Example 1. Power Consumption Example

For a GPIO address pin loaded with 50 pF capacitance, operating at 3.3 V, and with a 150 MHz clock, toggling at its maximum possible rate (75 MHz), the current consumption is

$$I = 50 \times 10^{-12} \times 3.3 \times 75 \times 10^6 = 12.375 \text{ mA} \quad \text{Eqn. 2}$$

The maximum internal current (I_{CCImax}) value reflects the typical possible switching of the internal buses on best-case operation conditions, which is not necessarily a real application case. The typical internal current (I_{CCItyp}) value reflects the average switching of the internal buses on typical operating conditions.

For applications that require very low current consumption, do the following:

- Minimize the number of pins that are switching.
- Minimize the capacitive load on the pins.

One way to evaluate power consumption is to use a current per MIPS measurement methodology to minimize specific board effects (for example, to compensate for measured board current not caused by the DSP). Use the test algorithm, specific test current measurements, and the following equation to derive the current per MIPS value.

$$I/MIPS = I/MHz = (I_{typF2} - I_{typF1}) / (F2 - F1) \quad \text{Eqn. 3}$$

where : I_{typF2} =current at F2
 I_{typF1} =current at F1
F2=high frequency (any specified operating frequency)
F1=low frequency (any specified operating frequency lower than F2)

NOTE

F1 should be significantly less than F2. For example, F2 could be 66 MHz and F1 could be 33 MHz. The degree of difference between F1 and F2 determines the amount of precision with which the current rating can be determined for an application.

2.5 DC Electrical Characteristics

Table 4 shows the DC electrical characteristics.

Table 4. DC Electrical Characteristics

	Characteristics	Symbol	Min	Typ	Max	Unit
Commercial	Supply voltages: • Core (Core_VDD) • PLL (PLLD_VDD, PLLD1_VDD)	V_{DD}	0.9	1	1.1	V
	Supply voltages: • I/O (IO_VDD) • PLL (PLL_P_VDD, PLLP1_VDD) • PLL (PLLA_VDD, PLLA1_VDD)	V_{DDIO}	3.14	3.3	3.46	V
Automotive	Supply voltages: • Core (Core_VDD) • PLL (PLLD_VDD, PLLD1_VDD)	V_{DD}	0.95	1	1.05	V
	Supply voltages: • I/O (IO_VDD) • PLL (PLL_P_VDD, PLLP1_VDD) • PLL (PLLA_VDD, PLLA1_VDD)	V_{DDIO}	3.14	3.3	3.46	V
Note: To avoid a high current condition and possible system damage, all 3.3 V supplies must rise before the 1.0 V supplies rise.						
Input low voltage		V_{IL}	-0.3	—	0.8	V
Input leakage current		I_{IN}	—	—	± 84	μA
Clock pin Input Capacitance (EXTAL)		C_{IN}	—	18	—	pF
High impedance (off-state) input current (@ 3.3 V or 0 V)		I_{TSI}	-10	—	10	μA
Output high voltage $I_{OH} = -12$ mA LSYNC_OUT, LALE, LCLK Pins $I_{OH} = -16$ mA, TDO Pin $I_{OH} = -24$ mA		V_{OH}	2.4	—	—	V
Output low voltage $I_{OL} = 12$ mA LSYNC_OUT, LALE, LCLK Pins $I_{OL} = 16$ mA, TDO Pins $I_{OL} = 24$ mA		V_{OL}	—	—	0.4	V
Internal pull-up resistor		R_{PU}	64	92	142	kΩ
Internal pull-down resistor		R_{PD}	57	90	157	kΩ
Commercial	Internal supply current ¹ (core only) at internal clock of 200 MHz • In Normal mode • In Wait mode • In Stop mode ²	I_{CCI}	—	224	445	mA
		I_{CCW}	—	121	353	mA
		I_{CCS}	—	90	327	mA

Table 4. DC Electrical Characteristics (Continued)

	Characteristics	Symbol	Min	Typ	Max	Unit
Automotive	• In Normal Mode	I_{CCI}	—	242	496	mA
	• In Wait Mode	I_{CCW}	—	125	409	mA
	• In Stop mode	I_{CCS}	—	107	376	mA
Input capacitance		C_{IN}	—	—	10	pF

Notes:

1. The Current Consumption section provides a formula to compute the estimated current requirements in Normal mode. In order to obtain these results, all inputs must be terminated (i.e., not allowed to float). Measurements are based on synthetic intensive DSP benchmarks. The power consumption numbers in this specification are 90% of the measured results of this benchmark. This reflects typical DSP applications. Typical internal supply current is measured with $V_{CORE_VDD} = 1.0\text{ V}$, $V_{DD_IO} = 3.3\text{ V}$ at $T_J = 25^\circ\text{ C}$. Maximum internal supply current is measured with $V_{CORE_VDD} = 1.10\text{ V}$, $V_{IO_VDD} = 3.4\text{ V}$ at $T_J = 100^\circ\text{ C}$.
2. In order to obtain these results, all inputs, which are not disconnected at Stop mode, must be terminated (i.e., not allowed to float).

2.6 AC Electrical Characteristics

The timing waveforms shown in the AC electrical characteristics section are tested with a V_{IL} maximum of 0.8 V and a V_{IH} minimum of 2.0 V for all pins. AC timing specifications, which are referenced to a device input signal, are measured in production with respect to the 50% point of the respective input signal’s transition. DSP56720/DSP56721 output levels are measured with the production test machine V_{OL} and V_{OH} reference levels set at 0.4 V and 2.4 V, respectively.

2.7 Internal Clocks

Internal clock characteristics are listed in [Table 5](#).

Table 5. Internal Clocks

No.	Characteristics	Symbol	Min	Typ	Max	Unit	Condition
1	Comparison Frequency	F_{ref}	2	—	8	MHz	$F_{ref} = F_{in}/NR$
2	Input Clock Frequency	F_{in}	Max = 200 MHz				—
3	PLL VCO Frequency	F_{vco}	200	—	400	MHz	$F_{vco} = (F_{in} \times NF)/NR$
4	Output Clock Frequency ^[1] • with PLL enabled • with PLL disabled	F_{out}	25 —	—	200 200	MHz	$F_{out} = F_{vco}/NO$ $F_{out} = F_{in}$
5	Duty Cycle	—	40	50	60	%	$F_{vco} = 200\text{ MHz} - 400\text{ MHz}$

Notes:

F_{in} = External frequency, NF = Multiplication Factor, NR = Predivision Factor, NO = Output Divider

2.8 External Clock Operation

The DSP56720/DSP56721 system clock is derived from the on-chip oscillator or is externally supplied. To use the on-chip oscillator, connect a crystal and associated resistor/capacitor components to EXTAL and XTAL; see the example in [Figure 9](#).

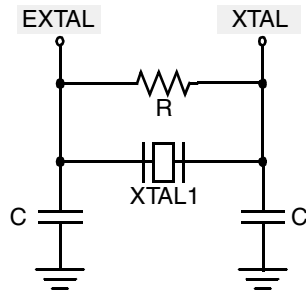

Suggested component values:

$$F_{osc} = 24.576 \text{ MHz}$$

$$R = 1 \text{ M} \pm 10\%$$

$$C (\text{EXTAL}) = 18 \text{ pF}$$

$$C (\text{XTAL}) = 18 \text{ pF}$$

Calculations are for a 5 – 30 MHz crystal with the following parameters:

- Shunt capacitance (C_0) of 10 pF – 12 pF
- Series resistance 40 Ohm
- Drive level of 10 μW

Figure 9. Using the On-Chip Oscillator

If the DSP56720/DSP56721 system clock is an externally supplied square wave voltage source, it is connected to EXTAL (Figure 10). When the external square wave source is connected to EXTAL, the XTAL pin is not used.

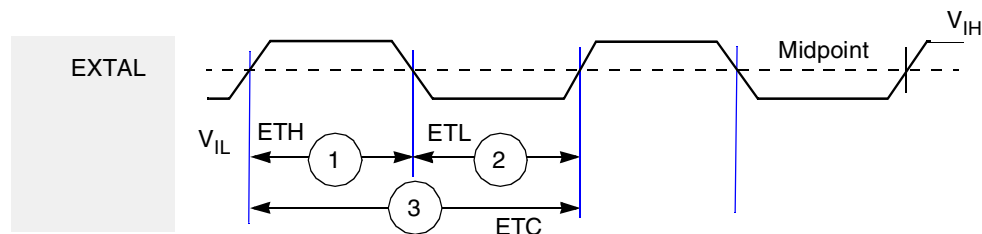

Note: The midpoint is $0.5 (V_{IH} + V_{IL})$.

Figure 10. External Clock Timing

Table 6 lists the clock operation.

Table 6. Clock Operation

No.	Characteristics	Symbol	Min	Max	Units
1	EXTAL input high ¹ (40% to 60% duty cycle) • Crystal oscillator • Square wave input	Eth	16.67 2.5	100 inf	ns
2	EXTAL input low ¹ (40% to 60% duty cycle) • Crystal oscillator • Square wave input	Etl	16.67 2.5	100 inf	ns
3	EXTAL cycle time • With PLL disabled • With PLL enabled	Etc	5 33.3	inf 500	ns
4	Instruction cycle time • With PLL disabled • With PLL enabled	Tc	5.00 5.00	inf 5120	ns

Notes:

1. Measured at 50% of the input transition.
2. The indicated duty cycle is for the specified maximum frequency for which a part is rated. The minimum clock high or low time required for correct operation, however, remains the same at lower operating frequencies; therefore, when a lower clock frequency is used, the signal symmetry may vary from the specified duty cycle as long as the minimum high time and low time requirements are met.

2.9 Reset, Stop, Mode Select, and Interrupt Timing

Table 7 shows the reset, stop, mode select, and interrupt timing.

Table 7. Reset, Stop, Mode Select, and Interrupt Timing Parameters

No.	Characteristics	Expression	Min	Max	Unit
10	Delay from $\overline{\text{RESET}}$ assertion to all pins at reset value ³	—	—	11	ns
11	Required $\overline{\text{RESET}}$ duration ⁴ <ul style="list-style-type: none"> Power on, external clock generator, PLL disabled Power on, external clock generator, PLL enabled 	$2 \times T_C$ $2 \times T_C$	10 10	— —	ns ns
13	Syn reset deassert delay time <ul style="list-style-type: none"> Minimum Maximum (PLL enabled) 	$2 \times T_C$ $(2 \times T_C) + T_{\text{LOCK}}$	10 200	— —	ns us
14	Mode select setup time	—	10.0	—	ns
15	Mode select hold time	—	12	—	ns
16	Minimum edge-triggered interrupt request assertion width	—	7	—	ns
17	Minimum edge-triggered interrupt request deassertion width	—	4	—	ns
18	Delay from interrupt trigger to interrupt code execution	$10 \times T_C + 4$	54	—	ns
19	Duration of level sensitive $\overline{\text{IRQA}}$ assertion to ensure interrupt service (when exiting Stop) ^{1, 2, 3} <ul style="list-style-type: none"> PLL is active during Stop and Stop delay is enabled (OMR Bit 6 = 0) PLL is active during Stop and Stop delay is not enabled (OMR Bit 6 = 1) PLL is not active during Stop and Stop delay is enabled (OMR Bit 6 = 0) PLL is not active during Stop and Stop delay is not enabled (OMR Bit 6 = 1) 	$(128 \text{ Kbytes} \times T_C)$ $25 \times T_C$ $(128 \text{ Kbytes} \times T_C) + T_{\text{LOCK}}$ $(25 \times T_C) + T_{\text{LOCK}}$	655 125 855 200	— — — —	μs ns μs μs
20	• Delay from $\overline{\text{IRQA}}$, $\overline{\text{IRQB}}$, $\overline{\text{IRQC}}$, $\overline{\text{IRQD}}$, $\overline{\text{NMI}}$ assertion to general-purpose transfer output valid caused by first interrupt instruction execution ¹	$10 \times T_C + 3.8$	—	53.8	ns
21	Interrupt Requests Rate ¹ <ul style="list-style-type: none"> ESAI, ESAI_1, ESAI_2, ESAI_3, SHI, SHI_1, Timer, Timer_1 DMA $\overline{\text{IRQ}}$, $\overline{\text{NMI}}$ (edge trigger) $\overline{\text{IRQ}}$ (level trigger) 	$12 \times T_C$ $8 \times T_C$ $8 \times T_C$ $12 \times T_C$	— — — —	60.0 40.0 40.0 60.0	ns ns ns ns

Table 7. Reset, Stop, Mode Select, and Interrupt Timing Parameters

No.	Characteristics	Expression	Min	Max	Unit
22	DMA Requests Rate				
	• Data read from ESAI, ESAI_1, ESAI_2, ESAI_3, SHI, SHI_1	$6 \times T_C$	—	30.0	ns
	• Data write to ESAI, ESAI_1, ESAI_2, ESAI_3, SHI, SHI_1	$7 \times T_C$	—	35.0	ns
	• Timer, Timer_1	$2 \times T_C$	—	10.0	ns
	• \overline{IRQ} , \overline{NMI} (edge trigger)	$3 \times T_C$	—	15.0	ns

Notes:

1. When using fast interrupts and when \overline{IRQA} , \overline{IRQB} , \overline{IRQC} , and \overline{IRQD} are defined as level-sensitive, timings 19 through 21 apply to prevent multiple interrupt service. To avoid these timing restrictions, the Edge-triggered mode is recommended when using fast interrupts. Long interrupts are recommended when using Level-sensitive mode.
2. For PLL disable, if using an external clock (PCTL Bit 13 = 1), no stabilization delay is required and recovery time will be defined by the OMR Bit 6 settings.
For PLL enable, (if bit 12 of the PCTL register is 0), the PLL is shut down during Stop. Recovering from Stop requires the PLL to get locked. The PLL lock procedure duration, PLL Lock Cycles (PLC), may be in the range of 200 μ s.
3. Periodically sampled and not 100% tested.
4. \overline{RESET} duration is measured during the time in which \overline{RESET} is asserted, V_{DD} is valid, and the EXTAL input is active and valid. When V_{DD} is valid, but the other “required \overline{RESET} duration” conditions (as specified above) have not been yet met, the device circuitry will be in an uninitialized state that can result in significant power consumption and heat-up. Designs should minimize this state to the shortest possible duration.

Figure 11 shows the reset timing diagram.

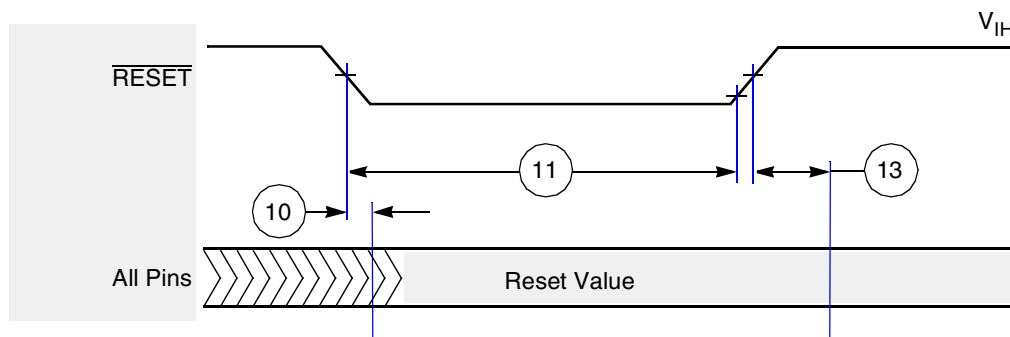

Figure 11. Reset Timing Diagram

Figure 12 shows the external fast interrupt timing diagram.

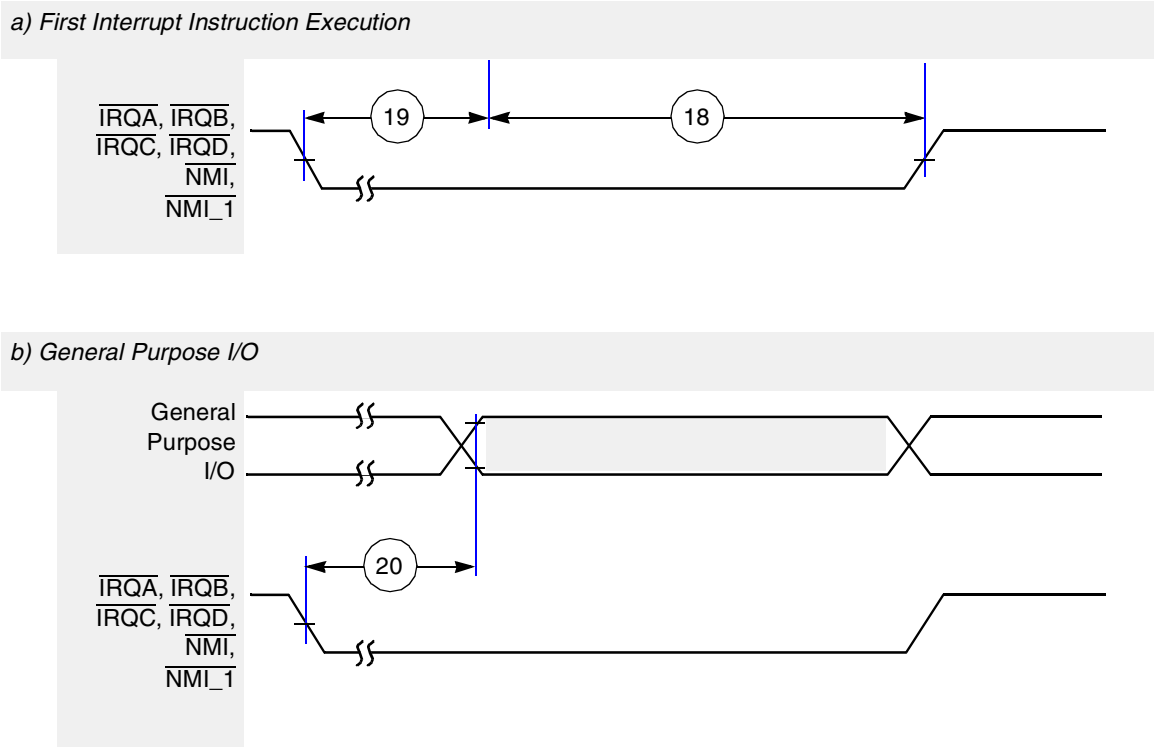

Figure 12. External Fast Interrupt Timing Diagram

Figure 13 shows the negative edge-triggered external interrupt timing diagram.

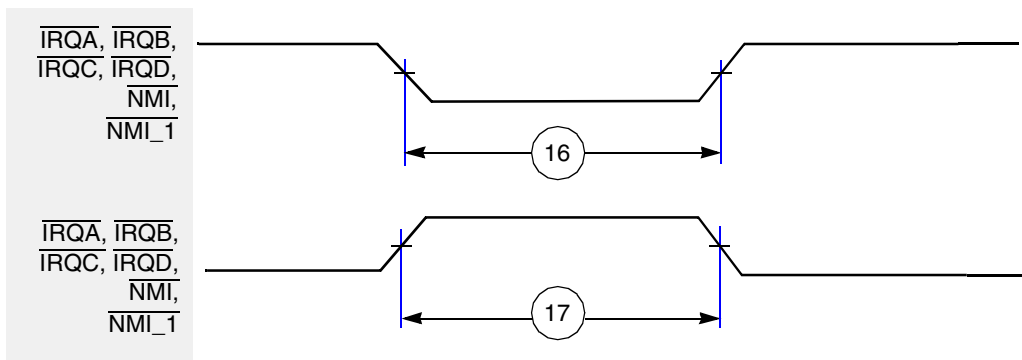

Figure 13. External Interrupt Timing Diagram (Negative Edge-Triggered)

Figure 14 shows the MODE select set up and hold timing diagram.

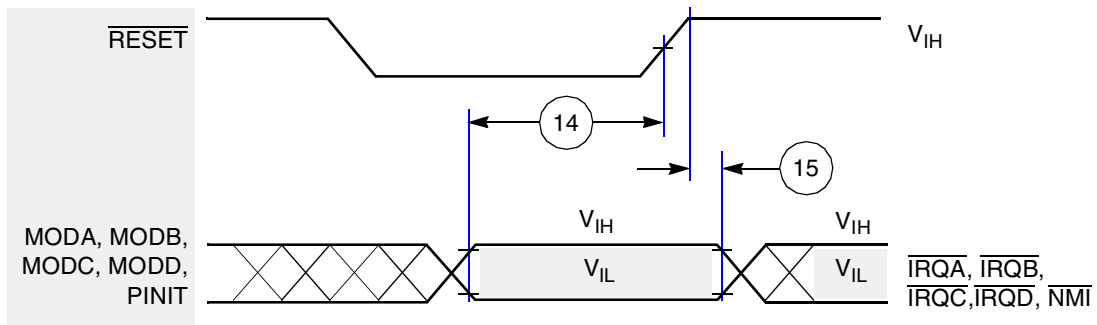

Figure 14. MODE Select Set Up and Hold Timing Diagram

2.10 Serial Host Interface (SHI) SPI Protocol Timing

Table 8 shows the SHI SPI protocol timing parameters and Figure 15 through Figure 18 show the timing diagrams.

Table 8. Serial Host Interface SPI Protocol Timing Parameters

No.	Characteristics ^{1,3,4}	Mode	Filter Mode	Expression	Min	Max	Unit
23	Minimum serial clock cycle = $t_{SPICC}(\text{min})$	Master	Bypassed	$10 \times T_C + 9$	59.0	—	ns
			Very Narrow	$10 \times T_C + 9$	59.0	—	ns
			Narrow	$10 \times T_C + 133$	183.0	—	ns
			Wide	$10 \times T_C + 333$	373.0	—	ns
		Slave	Bypassed	$2.0 \times T_C + 19.6$	59.2	—	ns
			Very Narrow	$2.0 \times T_C + 19.6$	59.2	—	ns
			Narrow	$2.0 \times T_C + 86.6$	193.2	—	ns
			Wide	$2.0 \times T_C + 186.6$	393.2	—	ns
XX	Tolerable Spike width on data or clock in	—	Bypassed	—	—	0	ns
			Very Narrow	—	—	10	ns
			Narrow	—	—	50	ns
			Wide	—	—	100	ns
24	Serial clock high period	Master	Bypassed	$0.5 \times (t_{SPICC})$	29.5	—	ns
			Very Narrow	$0.5 \times (t_{SPICC})$	29.5	—	ns
			Narrow	$0.5 \times (t_{SPICC})$	91.5	—	ns
			Wide	$0.5 \times (t_{SPICC})$	186.5	—	ns
		Slave	Bypassed	$2.0 \times T_C + 19.6$	29.6	—	ns
			Very Narrow	$2.0 \times T_C + 19.6$	29.6	—	ns
			Narrow	$2.0 \times T_C + 86.6$	96.6	—	ns
			Wide	$2.0 \times T_C + 186.6$	196.6	—	ns

Table 8. Serial Host Interface SPI Protocol Timing Parameters (Continued)

No.	Characteristics ^{1,3,4}	Mode	Filter Mode	Expression	Min	Max	Unit
25	Serial clock low period	Master	Bypassed	$0.5 \times (t_{SPICC})$	29.5	—	ns
			Very Narrow	$0.5 \times (t_{SPICC})$	29.5	—	ns
			Narrow	$0.5 \times (t_{SPICC})$	91.5	—	ns
			Wide	$0.5 \times (t_{SPICC})$	186.5	—	ns
		Slave	Bypassed	$2.0 \times T_C + 19.6$	29.6	—	ns
			Very Narrow	$2.0 \times T_C + 19.6$	29.6	—	ns
			Narrow	$2.0 \times T_C + 86.6$	96.6	—	ns
			Wide	$2.0 \times T_C + 186.6$	196.6	—	ns
26	Serial clock rise/fall time	Master	—	—	—	—	ns
		Slave	—	—	—	5	ns
27	\overline{SS} assertion to first SCK edge CPHA = 0	Slave	Bypassed	$2.0 \times T_C + 15$	25	—	ns
			Very Narrow	$2.0 \times T_C + 5$	15	—	ns
			Narrow	—	0	—	ns
			Wide	—	0	—	ns
	CPHA = 1	Slave	Bypassed	—	10	—	ns
			Very Narrow	—	0	—	ns
			Narrow	—	0	—	ns
			Wide	—	0	—	ns
28	Last SCK edge to \overline{SS} not asserted	Slave	Bypassed	—	12	—	ns
			Very Narrow	—	22	—	ns
			Narrow	—	100	—	ns
			Wide	—	200	—	ns
29	Data input valid to SCK edge (data input set-up time)	Master /Slave	Bypassed	—	0	—	ns
			Very Narrow	—	0	—	ns
			Narrow	—	0	—	ns
			Wide	—	0	—	ns
30	SCK last sampling edge to data input not valid	Master /Slave	Bypassed	$3.0 \times T_C$	15	—	ns
			Very Narrow	$3.0 \times T_C + 25$	40	—	ns
			Narrow	$3.0 \times T_C + 55$	70	—	ns
			Wide	$3.0 \times T_C + 85$	100.0	—	ns
31	\overline{SS} assertion to data out active	Slave	—	—	5	—	ns
32	\overline{SS} deassertion to data high impedance ²	Slave	—	—	—	9	ns

Table 8. Serial Host Interface SPI Protocol Timing Parameters (Continued)

No.	Characteristics ^{1,3,4}	Mode	Filter Mode	Expression	Min	Max	Unit
33	SCK edge to data out valid (data out delay time)	Master /Slave	Bypassed	$3.0 \times T_C + 30$	—	45	ns
			Very Narrow	$3.0 \times T_C + 95$	—	110	ns
			Narrow	$3.0 \times T_C + 120$	—	135	ns
			Wide	$3.0 \times T_C + 210$	—	225	ns
34	SCK edge to data out not valid (data out hold time)	Master /Slave	Bypassed	$2.0 \times T_C$	10	—	ns
			Very Narrow	$2.0 \times T_C + 5$	15	—	ns
			Narrow	$2.0 \times T_C + 45$	55	—	ns
			Wide	$2.0 \times T_C + 95$	105	—	ns
35	\overline{SS} assertion to data out valid (CPHA = 0)	Slave	—	—	—	14.0	ns
36	First SCK sampling edge to \overline{HREQ} output deassertion	Slave	Bypassed	$3.0 \times T_C + 30$	45	—	ns
			Very Narrow	$3.0 \times T_C + 40$	55	—	ns
			Narrow	$3.0 \times T_C + 80$	95	—	ns
			Wide	$3.0 \times T_C + 130$	145	—	ns
37	Last SCK sampling edge to \overline{HREQ} output not deasserted (CPHA = 1)	Slave	Bypassed	$4.0 \times T_C + 30$	50.0	—	ns
			Very Narrow	$4.0 \times T_C + 40$	60.0	—	ns
			Narrow	$4.0 \times T_C + 80$	100.0	—	ns
			Wide	$4.0 \times T_C + 130$	150.0	—	ns
38	\overline{SS} deassertion to \overline{HREQ} output not deasserted (CPHA = 0)	Slave	—	$3.0 \times T_C + 30$	45.0	—	ns
39	\overline{SS} deassertion pulse width (CPHA = 0)	Slave	—	$2.0 \times T_C$	10.0	—	ns
40	\overline{HREQ} in assertion to first SCK edge	Master	Bypassed	$0.5 \times T_{SPICC} + 3.0 \times T_C + 5$	49.5	—	ns
			Very Narrow	$0.5 \times T_{SPICC} + 3.0 \times T_C + 5$	49.5	—	ns
			Narrow	$0.5 \times T_{SPICC} + 3.0 \times T_C + 5$	111.5	—	ns
			Wide	$0.5 \times T_{SPICC} + 3.0 \times T_C + 5$	206.5	—	ns

Table 8. Serial Host Interface SPI Protocol Timing Parameters (Continued)

No.	Characteristics ^{1,3,4}	Mode	Filter Mode	Expression	Min	Max	Unit
41	$\overline{\text{HREQ}}$ in deassertion to last SCK sampling edge ($\overline{\text{HREQ}}$ in set-up time) (CPHA = 1)	Master	—	—	0	—	ns
42	First SCK edge to $\overline{\text{HREQ}}$ in not asserted ($\overline{\text{HREQ}}$ in hold time)	Master	—	—	0	—	ns
43	$\overline{\text{HREQ}}$ assertion width	Master	—	$3.0 \times T_C$	15	—	ns

Notes:

1. $V_{\text{CORE_VDD}} = 1.0 \pm 0.10 \text{ V}$; $T_J = -40^\circ\text{C}$ to 100°C ; $C_L = 50 \text{ pF}$.
2. Periodically sampled, not 100% tested.
3. All times assume noise free inputs.
4. All times assume internal clock frequency of 200 MHz.
5. SHI_1 specs match those of SHI.

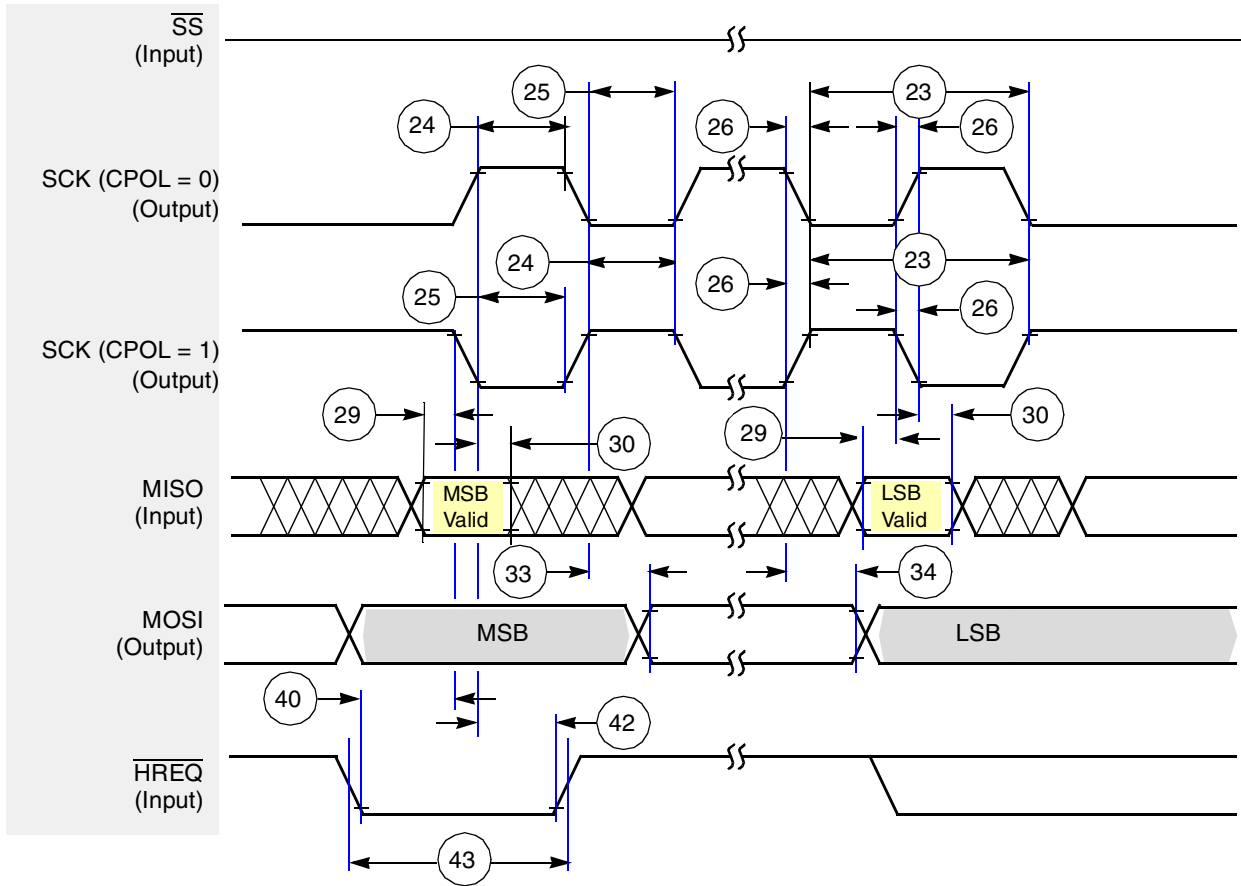

Figure 15. SPI Master Timing Diagram (CPHA = 0)

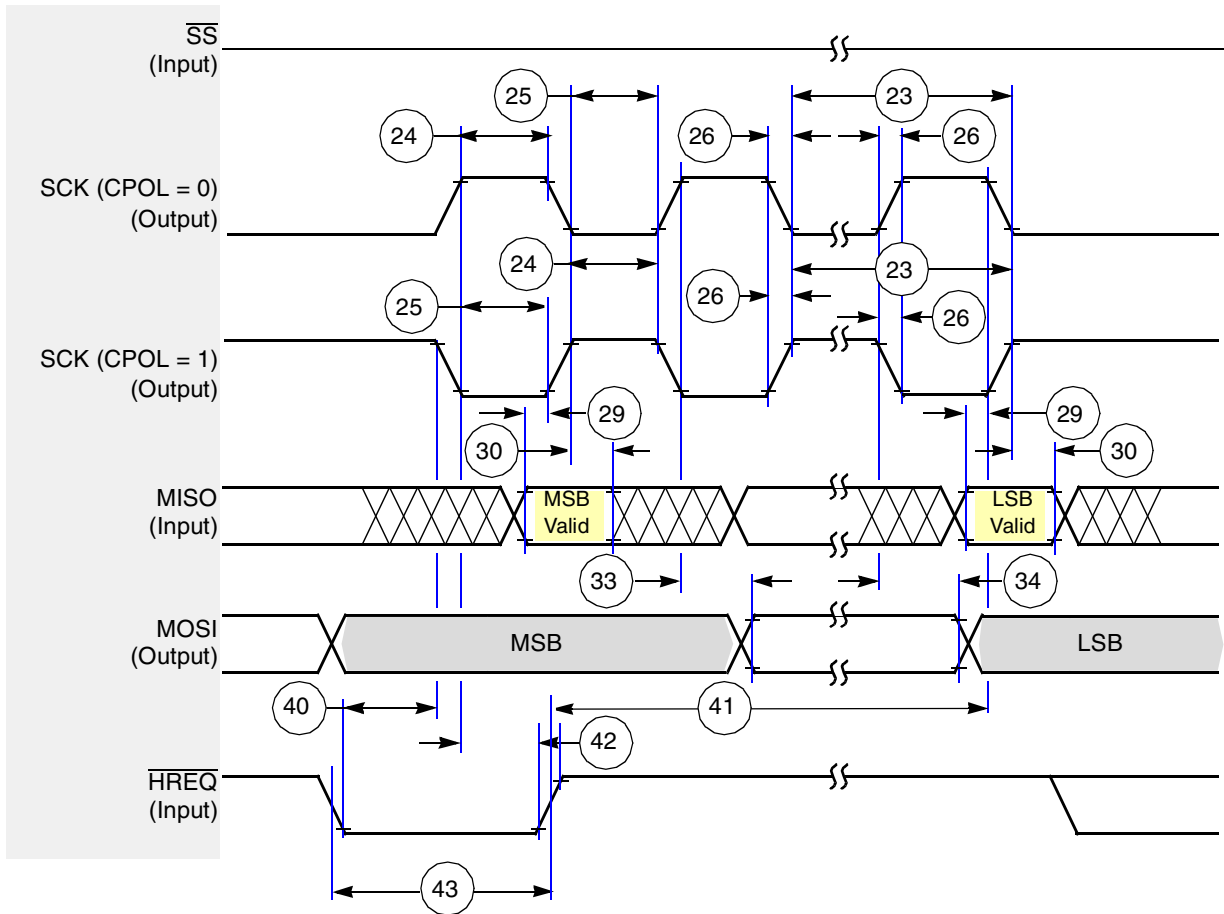

Figure 16. SPI Master Timing Diagram (CPHA = 1)

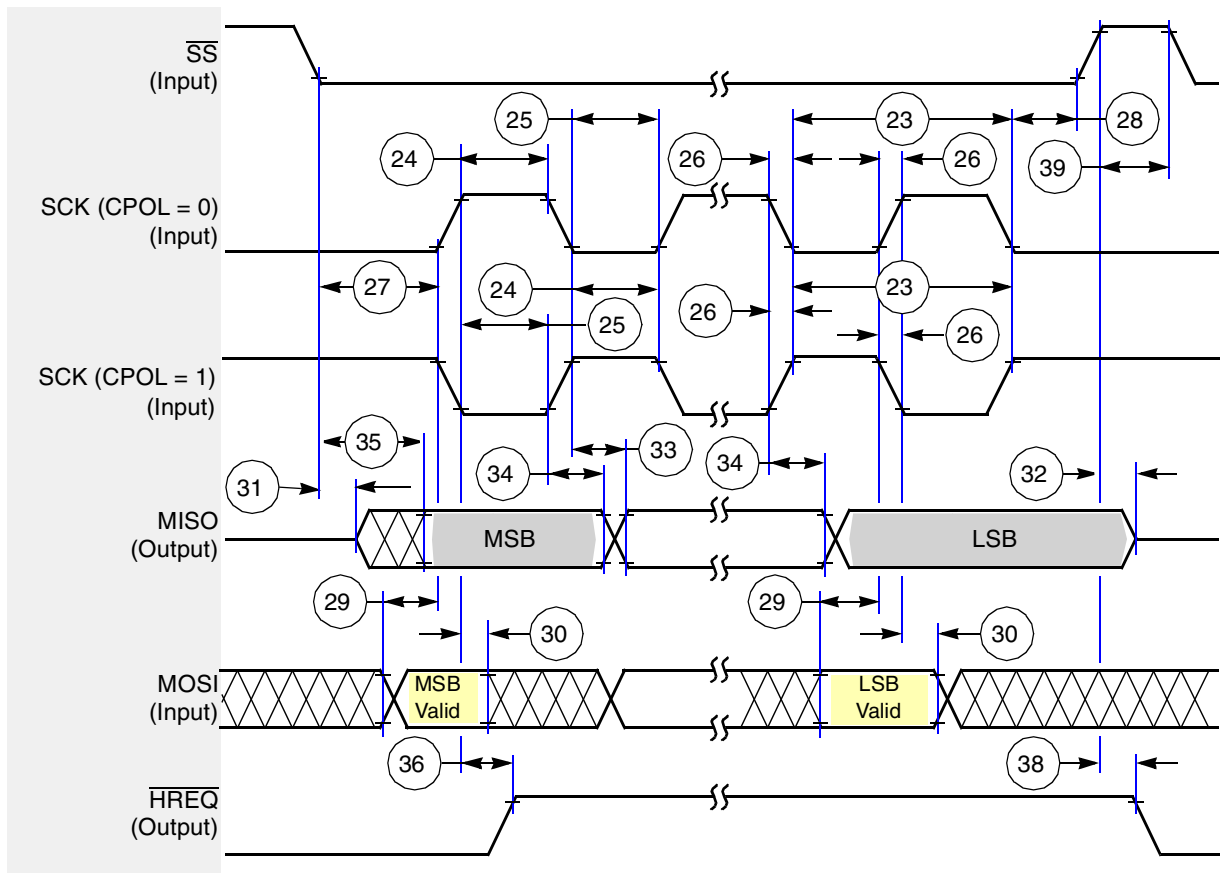

Figure 17. SPI Slave Timing Diagram (CPHA = 0)

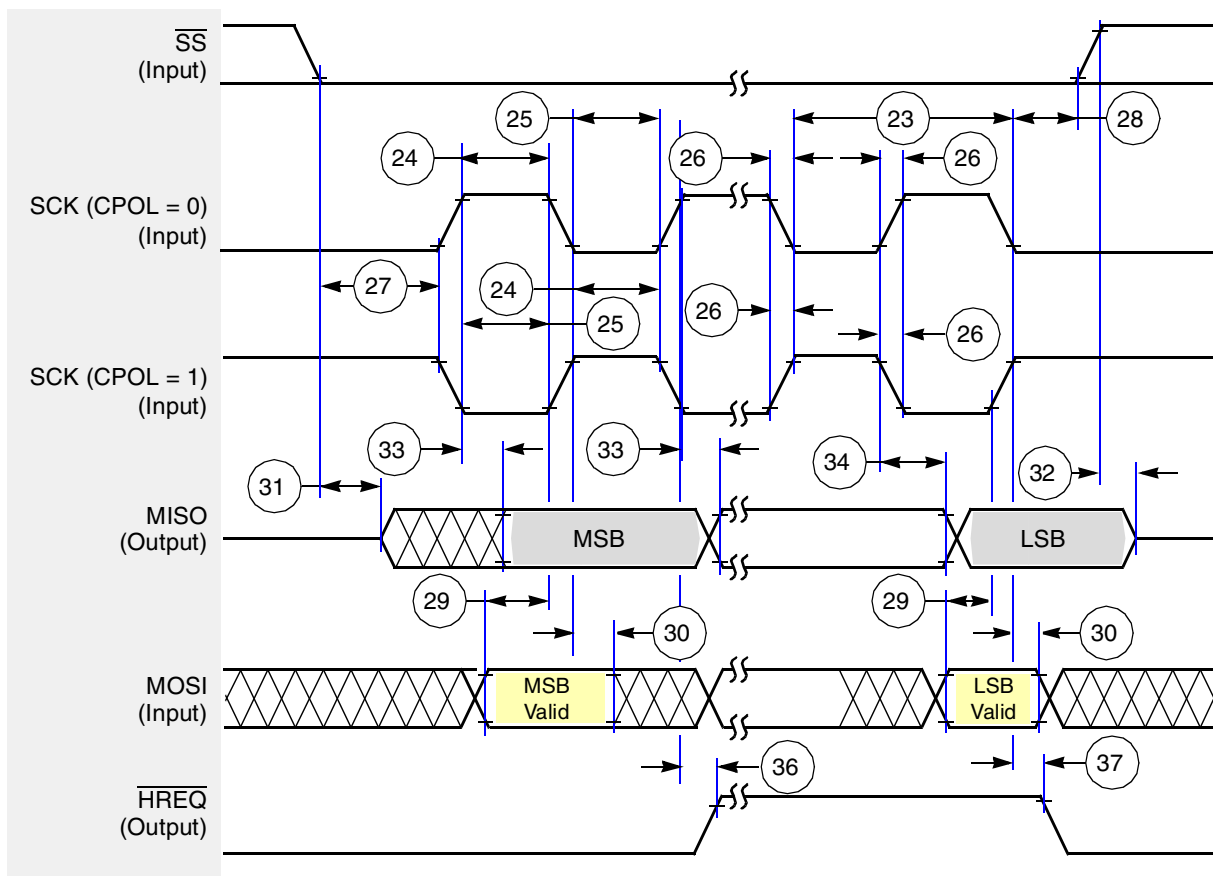

Figure 18. SPI Slave Timing Diagram (CPHA = 1)

2.11 Serial Host Interface (SHI) I²C Protocol Timing

Table 9 lists the SHI I²C protocol timing parameters and Figure 19 shows the timing diagram.

Table 9. SHI I²C Protocol Timing Parameters

Standard I ² C							
No.	Characteristics ^{1,2,3,4,5}	Symbol/ Expression	Standard		Fast-Mode		Unit
			Min	Max	Min	Max	
	Tolerable Spike Width on SCL or SDA Filters Bypassed	—	—	0	—	0	ns
	Very Narrow Filters enabled	—	—	10	—	10	ns
	Narrow Filters enabled	—	—	50	—	50	ns
	Wide Filters enabled.	—	—	100	—	100	ns
44	SCL clock frequency	F _{SCL}	—	100	—	400	kHz
44	SCL clock cycle	T _{SCL}	10	—	2.5	—	μs
45	Bus free time	T _{BUF}	4.7	—	1.3	—	μs
46	Start condition set-up time	T _{SUSTA}	4.7	—	0.6	—	μs
47	Start condition hold time	T _{HD;STA}	4.0	—	0.6	—	μs

Table 9. SHI I²C Protocol Timing Parameters (Continued)

Standard I ² C							
No.	Characteristics ^{1,2,3,4,5}	Symbol/ Expression	Standard		Fast-Mode		Unit
			Min	Max	Min	Max	
48	SCL low period	T _{LOW}	4.7	—	1.3	—	μs
49	SCL high period	T _{HIGH}	4.0	—	1.3	—	μs
50	SCL and SDA rise time ⁷	T _R	—	1000	—	300	ns
51	SCL and SDA fall time ⁷	T _F	—	5.0	—	5.0	ns
52	Data set-up time	T _{SU;DAT}	250	—	100	—	ns
53	Data hold time	T _{HD;DAT}	0.0	—	0.0	0.9	μs
54	DSP clock frequency • Filters bypassed • Very Narrow filters enabled • Narrow filters enabled • Wide filters enabled	F _{OSC}	10.6	—	28.5	—	MHz
			10.6	—	28.5	—	MHz
			11.8	—	39.7	—	MHz
			13.1	—	61.0	—	MHz
55	SCL low to data out valid	T _{VD;DAT}	—	3.4	—	0.9	μs
56	Stop condition setup time	T _{SU;STO}	4.0	—	0.6	—	μs
57	$\overline{\text{HREQ}}$ in deassertion to last SCL edge ($\overline{\text{HREQ}}$ in set-up time)	t _{SU;RQI}	0.0	—	0.0	—	ns
58	First SCL sampling edge to $\overline{\text{HREQ}}$ output deassertion ² • Filters bypassed • Very Narrow filters enabled • Narrow filters enabled • Wide filters enabled	T _{NG;RQO}	—	50.0	—	50.0	ns
			—	70.0	—	70.0	ns
			—	250.0	—	150.0	ns
			—	150.0	—	250.0	ns
59	Last SCL edge to $\overline{\text{HREQ}}$ output not deasserted ² • Filters bypassed • Very Narrow filters enabled • Narrow filters enabled • Wide filters enabled	T _{AS;RQO}	40	—	40	—	ns
			50	—	50	—	ns
			90	—	90	—	ns
			140	—	140	—	ns

Table 9. SHI I²C Protocol Timing Parameters (Continued)

Standard I ² C							
No.	Characteristics ^{1,2,3,4,5}	Symbol/ Expression	Standard		Fast-Mode		Unit
			Min	Max	Min	Max	
60	$\overline{\text{HREQ}}$ in assertion to first SCL edge <ul style="list-style-type: none"> • Filters bypassed • Very Narrow filters enabled • Narrow filters enabled • Wide filters enabled 	$T_{\text{AS;RQI}}$	4327	—	927	—	ns
			4317	—	917	—	ns
			4282	—	877	—	ns
			4227	—	827	—	ns
61	First SCL edge to $\overline{\text{HREQ}}$ is not asserted ($\overline{\text{HREQ}}$ in hold time.)	$t_{\text{HO;RQI}}$	0.0	—	0.0	—	ns

Notes:

1. $V_{\text{CORE_VDD}} = 1.00 \pm 0.10 \text{ V}$; $T_J = -40^\circ\text{C}$ to 100°C ; $C_L = 50 \text{ pF}$.
2. Pull-up resistor: $R_p(\text{min}) = 1.5\text{k}\Omega$.
3. Capacitive load: $C_b(\text{max}) = 50 \text{ pF}$.
4. All times assume noise free inputs.
5. All times assume internal clock frequency of 200 MHz.
6. SHI_1 specs match those of SHI.
7. Master Mode

2.12 Programming the SHI I²C Serial Clock

The programmed serial clock cycle, $T_{\text{I}^2\text{CCP}}$, is specified by the value of the HDM[7:0] and HRS bits of the HCKR (SHI clock control register).

The expression for $T_{\text{I}^2\text{CCP}}$ is

$$T_{\text{I}^2\text{CCP}} = [T_C \times 2 \times (\text{HDM}[7:0] + 1) \times (7 \times (1 - \text{HRS}) + 1)] \quad \text{Eqn. 4}$$

where

- HRS is the pre scaler rate select bit. When HRS is cleared, the fixed divide-by-eight pre scaler is operational. When HRS is set, the pre scaler is bypassed.
- HDM[7:0] are the divider modulus select bits. A divide ratio from 1 to 256 ($\text{HDM}[7:0] = \$00$ to $\$FF$) may be selected.

In I²C mode, the user may select a value for the programmed serial clock cycle from

$$6 \times T_C \quad (\text{if HDM}[7:0] = \$02 \text{ and HRS} = 1) \quad \text{Eqn. 5}$$

to

$$4096 \times T_C \quad (\text{if HDM}[7:0] = \$FF \text{ and HRS} = 0) \quad \text{Eqn. 6}$$

The programmed serial clock cycle ($T_{\text{I}^2\text{CCP}}$) should be chosen in order to achieve the desired SCL serial clock cycle (T_{SCL}), as shown in Equation 4.

$$T_{\text{I}^2\text{CCP}} + 3 \times T_C + 45\text{ns} + T_R \quad (\text{Nominal, SCL Serial Clock Cycle (TSCL) generated as master}) \quad \text{Eqn. 7}$$

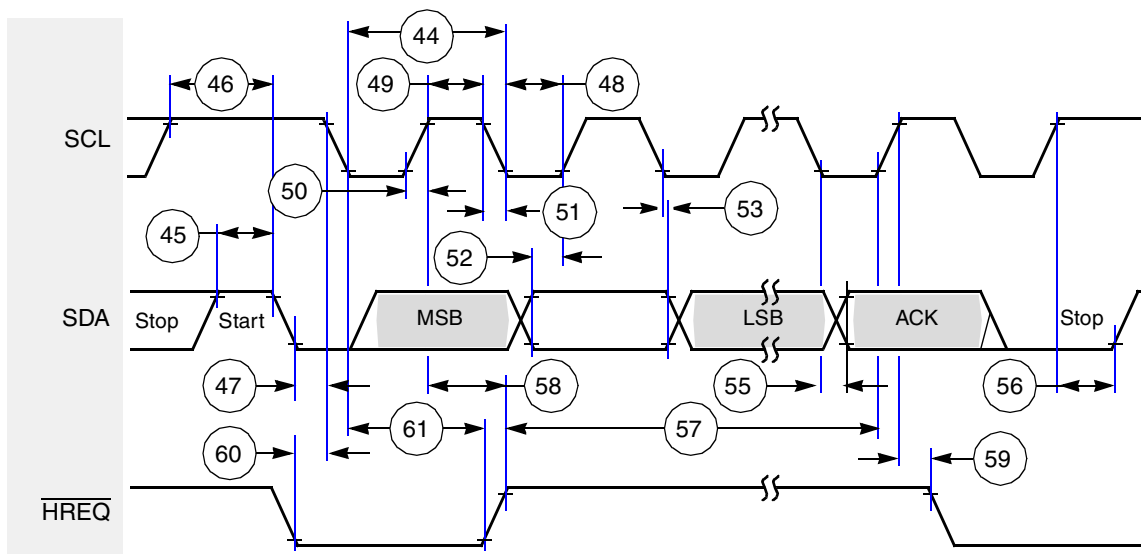

Figure 19. I²C Timing Diagram

2.13 Enhanced Serial Audio Interface (ESAI) Timing

Table 10 lists the ESAI timing parameters and Figure 20 through Figure 23 show the timing diagrams.

Table 10. Enhanced Serial Audio Interface Timing Parameters

No.	Characteristics ^{1, 3, 4}	Symbol	Expression ⁵	Min	Max	Condition ²	Unit
62	Clock cycle ⁵	t_{SSICC}	$4 \times T_C$ $4 \times T_C$	20.0 20.0	— —	i ck i ck	ns
63	Clock high period • For internal clock • For external clock	— —	$2 \times T_C$ $2 \times T_C$	10 10	— —	— —	ns
64	Clock low period • For internal clock • For external clock	— —	$2 \times T_C$ $2 \times T_C$	10 10	— —	— —	ns
65	SCKR rising edge to FSR out (bl) high	—	—	— —	17.0 7.0	x ck i ck a	ns
66	SCKR rising edge to FSR out (bl) low	—	—	— —	17.0 7.0	x ck i ck a	ns
67	SCKR rising edge to FSR out (wr) high ⁶	—	—	— —	19.0 9.0	x ck i ck a	ns
68	SCKR rising edge to FSR out (wr) low ⁶	—	—	— —	19.0 9.0	x ck i ck a	ns
69	SCKR rising edge to FSR out (wl) high	—	—	— —	16.0 6.0	x ck i ck a	ns
70	SCKR rising edge to FSR out (wl) low	—	—	— —	17.0 7.0	x ck i ck a	ns

Table 10. Enhanced Serial Audio Interface Timing Parameters (Continued)

No.	Characteristics ^{1, 3, 4}	Symbol	Expression ⁵	Min	Max	Condition ²	Unit
71	Data in setup time before SCKR (SCK in synchronous mode) falling edge	—	—	5 19.0	— —	x ck i ck	ns
72	Data in hold time after SCKR falling edge	—	—	3.5 9.0	— —	x ck i ck	ns
73	FSR input (bl, wr) high before SCKR falling edge ⁶	—	—	2.0 12.0	— —	x ck i ck a	ns
74	FSR input (wl) high before SCKR falling edge	—	—	2.0 12.0	— —	x ck i ck a	ns
75	FSR input hold time after SCKR falling edge	—	—	2.5 8.5	— —	x ck i ck a	ns
76	Flags input setup before SCKR falling edge	—	—	0.0 19.0	— —	x ck i ck s	ns
77	Flags input hold time after SCKR falling edge	—	—	6.0 0.0	— —	x ck i ck s	ns
78	SCKT rising edge to FST out (bl) high	—	—	— —	14 8.0	x ck i ck	ns
79	SCKT rising edge to FST out (bl) low	—	—	— —	20.0 10.0	x ck i ck	ns
80	SCKT rising edge to FST out (wr) high ⁶	—	—	— —	20.0 10.0	x ck i ck	ns
81	SCKT rising edge to FST out (wr) low ⁶	—	—	— —	22.0 12.0	x ck i ck	ns
82	SCKT rising edge to FST out (wl) high	—	—	— —	14 9.0	x ck i ck	ns
83	SCKT rising edge to FST out (wl) low	—	—	— —	14 10.0	x ck i ck	ns
84	SCKT rising edge to data out enable from high impedance	—	—	— —	22.0 17.0	x ck i ck	ns
85	SCKT rising edge to transmitter #0 drive enable assertion	—	—	— —	17.0 11.0	x ck i ck	ns
86	SCKT rising edge to data out valid	—	—	— —	13 13.0	x ck i ck	ns
87	SCKT rising edge to data out high impedance ⁷	—	—	— —	13 16.0	x ck i ck	ns
88	SCKT rising edge to transmitter #0 drive enable deassertion ⁷	—	—	— —	14.0 9.0	x ck i ck	ns
89	FST input (bl, wr) setup time before SCKT falling edge ⁶	—	—	2.0 18.0	— —	x ck i ck	ns
90	FST input (wl) setup time before SCKT falling edge	—	—	2.0 18.0	— —	x ck i ck	ns
91	FST input hold time after SCKT falling edge	—	—	4.0 5.0	— —	x ck i ck	ns

Table 10. Enhanced Serial Audio Interface Timing Parameters (Continued)

No.	Characteristics ^{1, 3, 4}	Symbol	Expression ⁵	Min	Max	Condition ²	Unit
92	FST input (wl) to data out enable from high impedance	—	—	—	21.0	—	ns
93	FST input (wl) to transmitter #0 drive enable assertion	—	—	—	14.0	—	ns
94	Flag output valid after SCKT rising edge	—	—	— —	14.0 9.0	x ck i ck	ns
95	HCKR/HCKT clock cycle	—	$2 \times T_C$	10	—	—	ns
96	HCKT input rising edge to SCKT output	—	—	—	18.0	—	ns
97	HCKR input rising edge to SCKR output	—	—	—	18.0	—	ns

Notes:

1. $V_{CORE_VDD} = 1.00 \pm 0.10$ V; $T_J = -40^\circ\text{C}$ to 100°C ; $C_L = 50$ pF.
2. i ck = internal clock
x ck = external clock
i ck a = internal clock, asynchronous mode
(Asynchronous implies that SCKT and SCKR are two different clocks.)
i ck s = internal clock, synchronous mode
(Synchronous implies that SCKT and SCKR are the same clock.)
3. bl = bit length
wl = word length
wr = word length relative
4. SCKT(SCKT pin) = transmit clock
SCKR(SCKR pin) = receive clock
FST(FST pin) = transmit frame sync
FSR(FSR pin) = receive frame sync
HCKT(HCKT pin) = transmit high frequency clock
HCKR(HCKR pin) = receive high frequency clock
5. For the internal clock, the external clock cycle is defined by T_C and the ESAI control register.
6. The word-relative frame sync signal waveform relative to the clock operates in the same manner as the bit-length frame sync signal waveform, but spreads from one serial clock before first bit clock (same as bit length frame sync signal), until the one before last bit clock of the first word in frame.
7. Periodically sampled and not 100% tested.
8. ESAI_1, ESAI_2, ESAI_3 specs match those of ESAI.

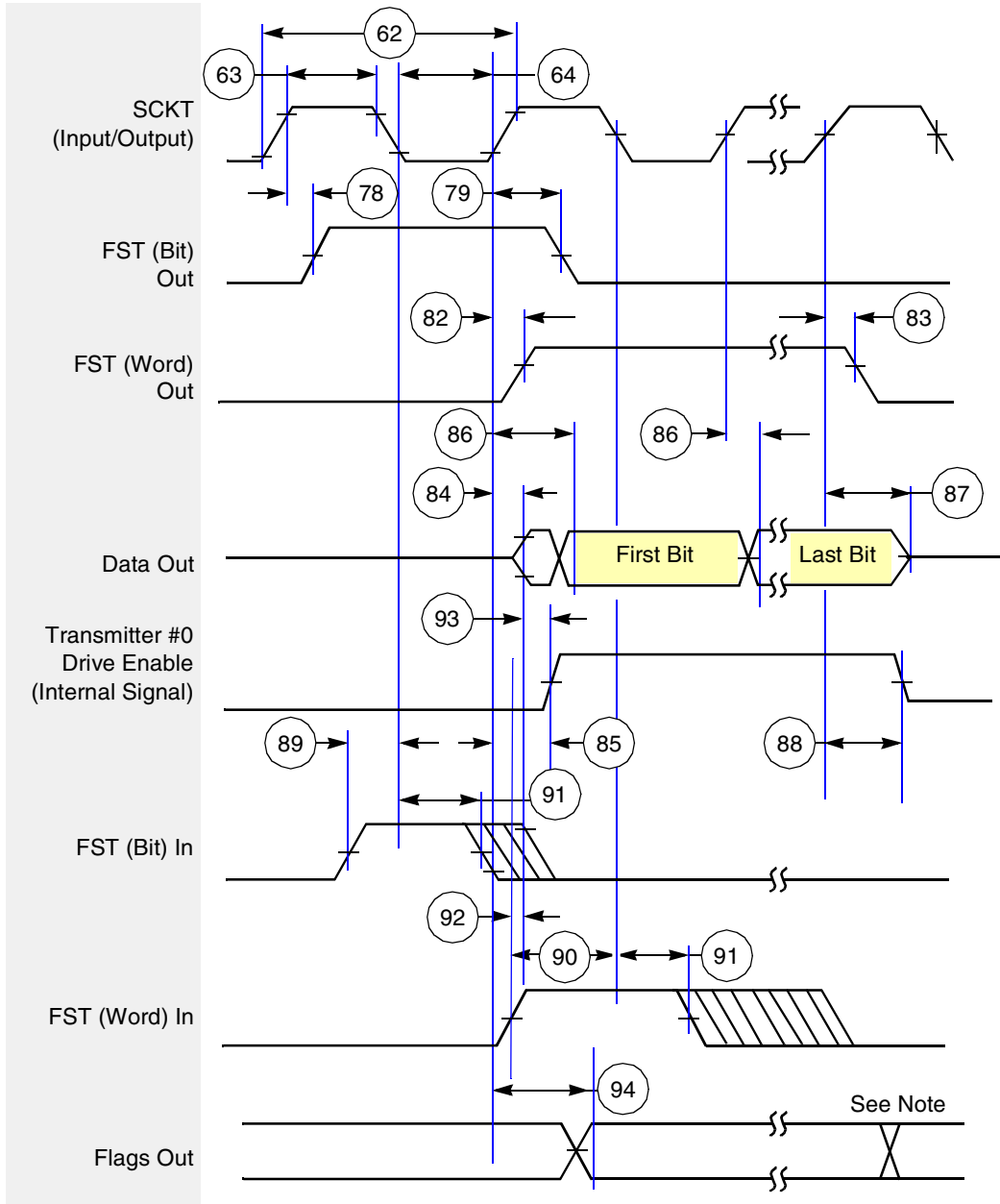

Note: In network mode, output flag transitions can occur at the start of each time slot within the frame. In normal mode, the output flag state is asserted for the entire frame period.

Figure 20. ESAI Transmitter Timing Diagram

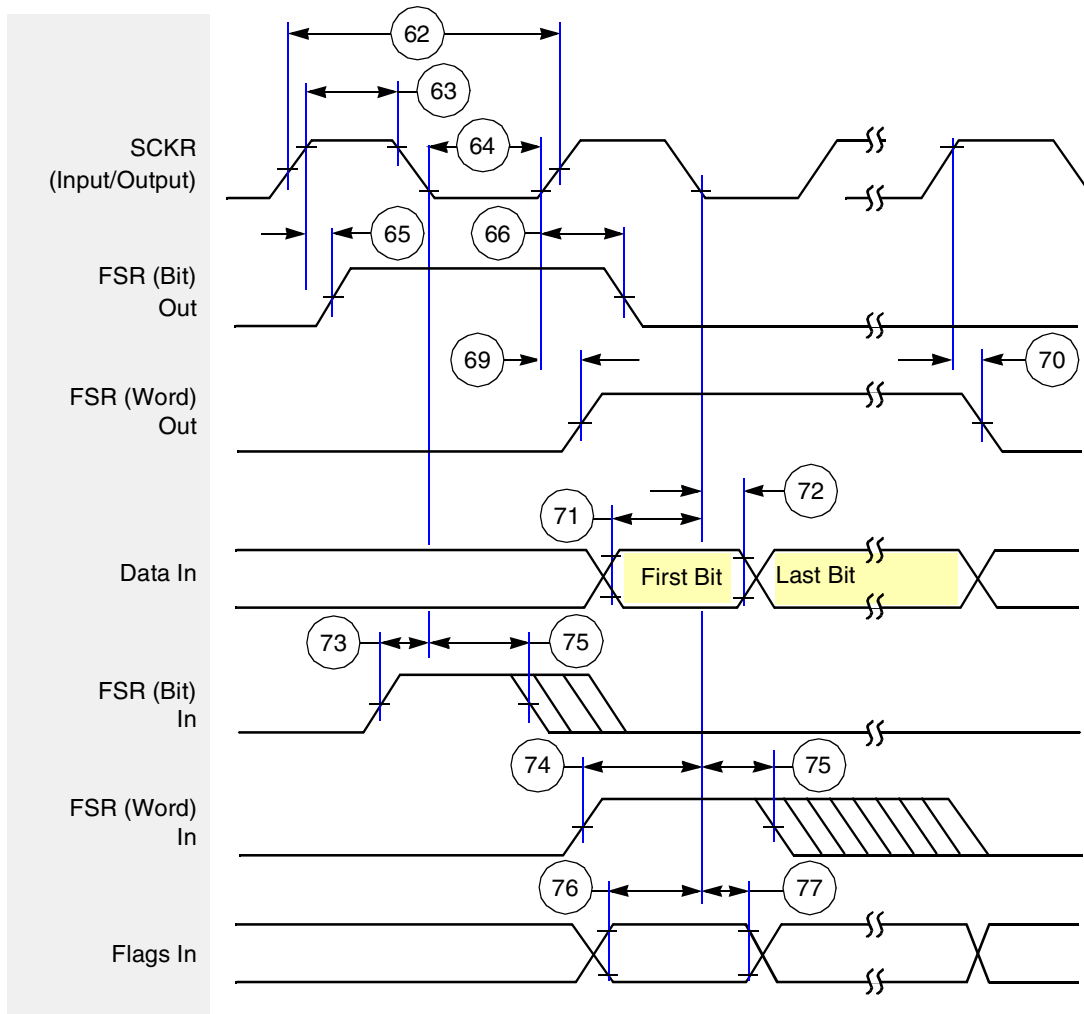

Figure 21. ESAI Receiver Timing Diagram

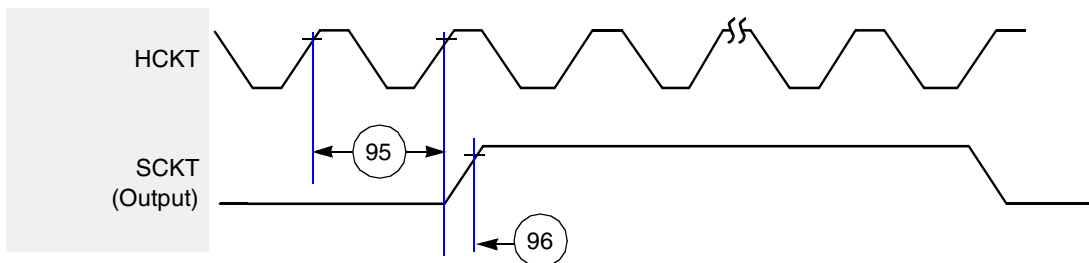

Figure 22. ESAI HCKT Timing Diagram

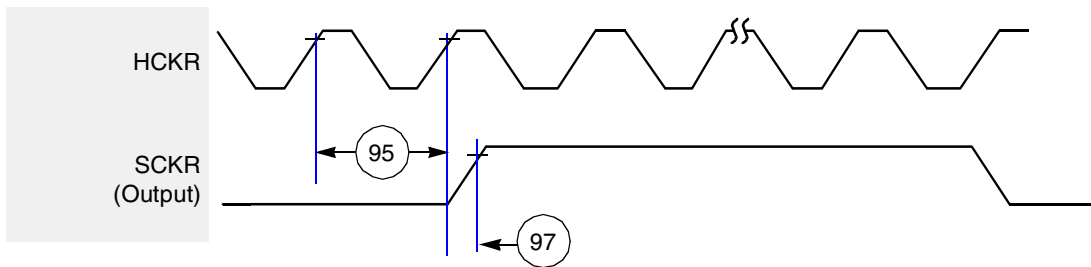

Figure 23. ESAI HCKR Timing

2.14 Timer Timing

Table 11 lists the timer timing parameters and Figure 24 shows the timing diagram.

Table 11. Timer Timing Parameters

No.	Characteristics	Expression			Unit
			Min	Max	
98	TIO Low	$2 \times T_C + 2.0$	12.0	—	ns
99	TIO High	$2 \times T_C + 2.0$	12.0	—	ns

Notes:

1. $V_{CORE_VDD} = 1.00 \text{ V} \pm 0.10 \text{ V}$; $T_J = -40^\circ\text{C}$ to 100°C , $C_L = 50 \text{ pF}$
2. TIMER_1 specs match those of TIMER

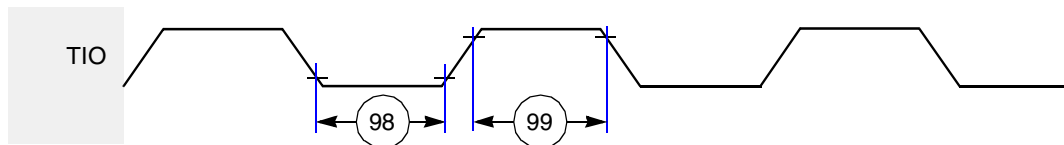

Figure 24. TIO Timer Event Input Restrictions Diagram

2.15 GPIO Timing

Table 12 lists the general purpose input and output (GPIO) timing and Figure 25 shows the timing diagram.

Table 12. GPIO Timing Parameters

No.	Characteristics ¹	Expression	Min	Max	Unit
100	Fsys edge to GPIO out valid (GPIO out delay time) ²	—	—	7	ns
101	Fsys edge to GPIO out not valid (GPIO out hold time) ²	—	—	7	ns
102	Fsys In valid to EXTAL edge (GPIO in set-up time) ²	—	2	—	ns
103	Fsys edge to GPIO in not valid (GPIO in hold time) ²	—	0	—	ns
104	Minimum GPIO pulse high width	$2 \times T_C$	10	—	ns

Table 12. GPIO Timing (Continued)Parameters (Continued)

No.	Characteristics ¹	Expression	Min	Max	Unit
105	Minimum GPIO pulse low width	$2 \times TC$	10	—	ns
106	GPIO out rise time	—	—	13.0	ns
107	GPIO out fall time	—	—	13.0	ns

Notes:

$V_{CORE_VDD} = 1.0 \text{ V} \pm 0.10 \text{ V}$; $T_J = -40^\circ\text{C}$ to 100°C ; $C_L = 50 \text{ pF}$

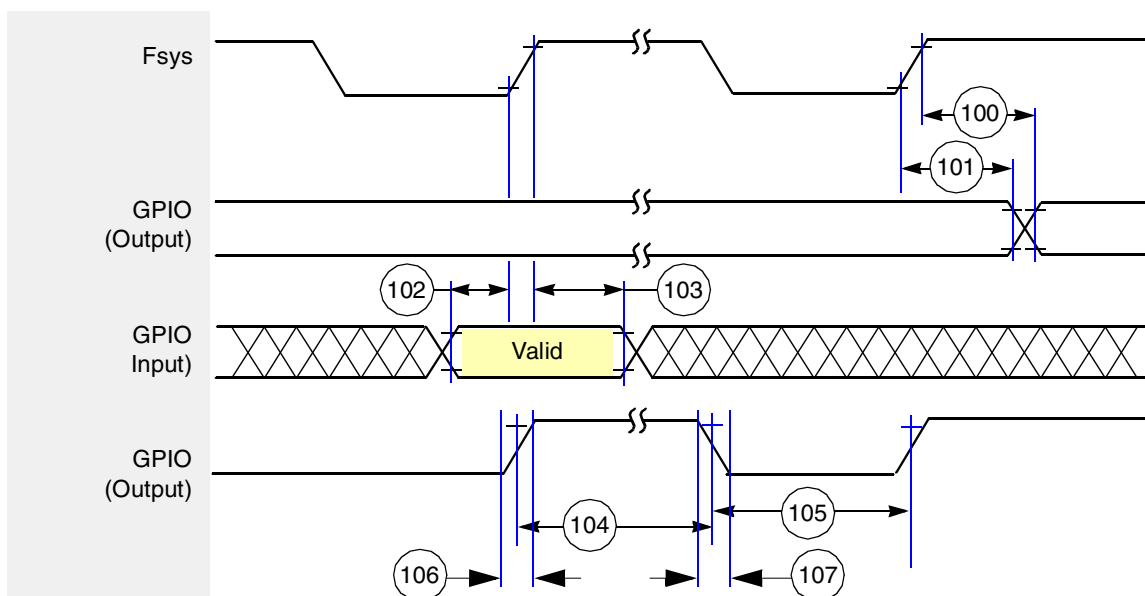

Figure 25. GPIO Timing Diagram

2.16 JTAG Timing

Table 13 lists the joint test action group (JTAG) timing parameters, and Figure 26 through Figure 28 show the timing diagrams.

Table 13. JTAG Timing Parameters

No.	Characteristics	All Frequencies		Unit
		Min	Max	
108	TCK frequency of operation ($1/(T_C \times 3)$; maximum 10 MHz)	—	10.0	MHz
109	TCK cycle time in Crystal mode	100.0	—	ns
110	TCK clock pulse width measured at 1.65 V	50.0	—	ns
111	TCK rise and fall times	—	3.0	ns
112	Boundary scan input data setup time	15.0	—	ns
113	Boundary scan input data hold time	24.0	—	ns
114	TCK low to output data valid	—	40.0	ns
115	TCK low to output high impedance	—	40.0	ns

Table 13. JTAG Timing Parameters (Continued)

No.	Characteristics	All Frequencies		Unit
		Min	Max	
116	TMS, TDI data setup time	5.0	—	ns
117	TMS, TDI data hold time	25.0	—	ns
118	TCK low to TDO data valid	—	44.0	ns
119	TCK low to TDO high impedance	—	44.0	ns

Notes:

1. $V_{CORE_VDD} = 1.0\text{ V} \pm 0.10\text{ V}$; $T_J = -40^\circ\text{C}$ to 100°C , $C_L = 50\text{ pF}$
2. All timings apply to OnCE module data transfers because it uses the JTAG port as an interface.

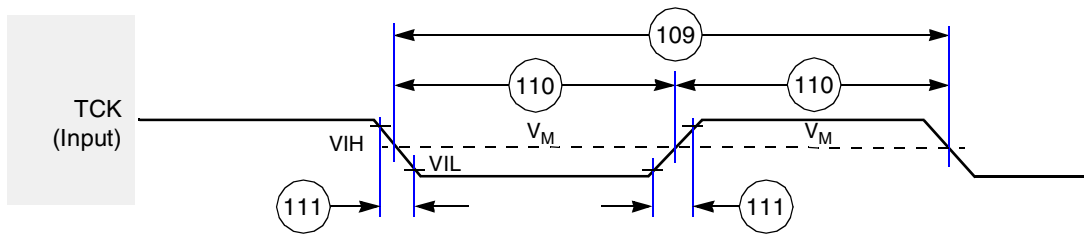

Figure 26. Test Clock Input Timing Diagram

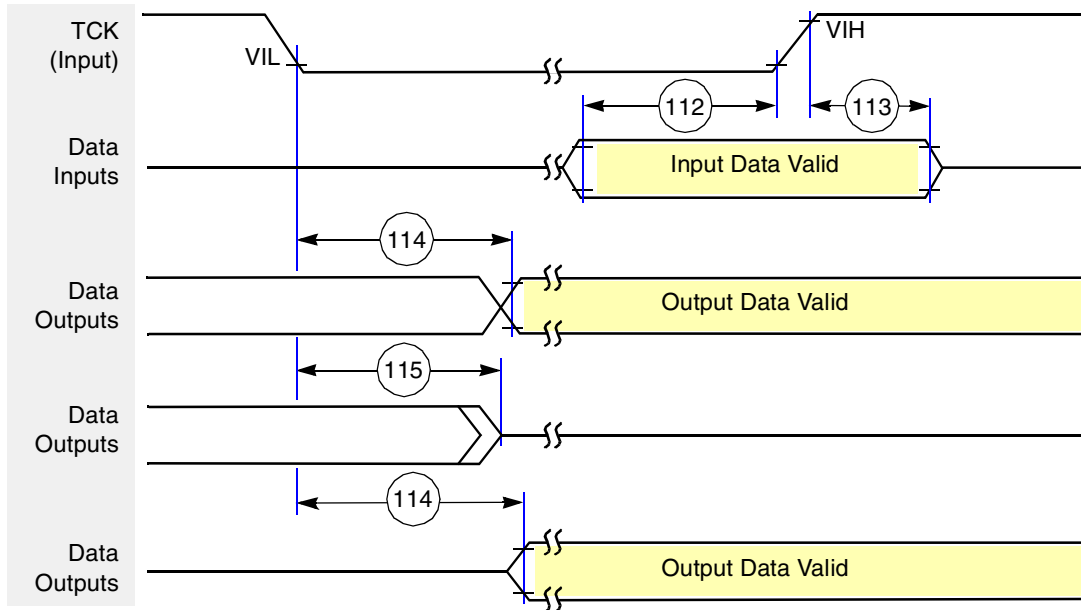

Figure 27. Debugger Port Timing Diagram

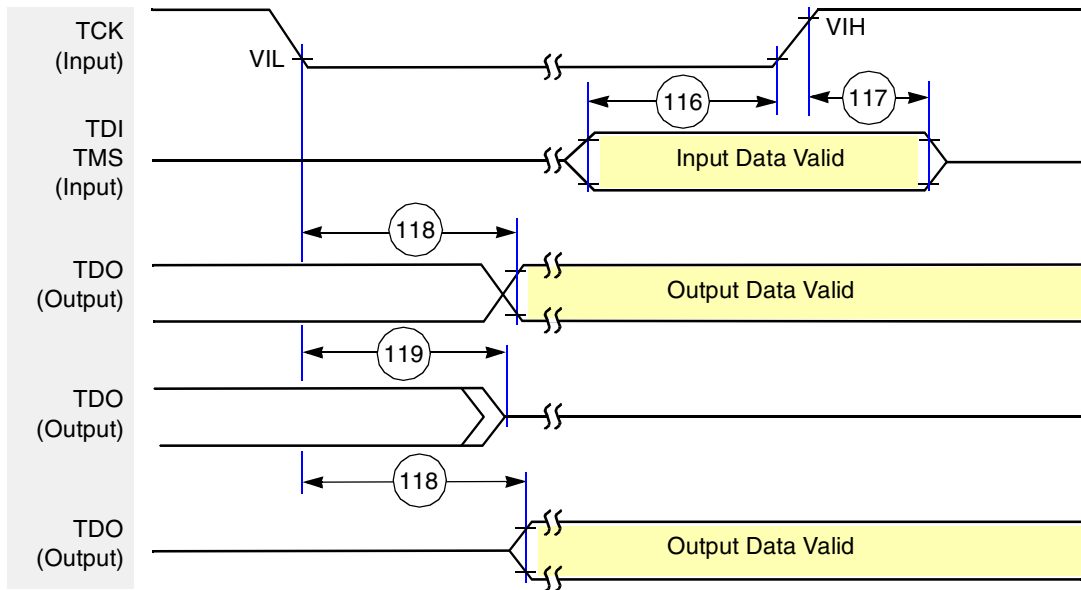

Figure 28. Test Access Port Timing Diagram

2.17 Watchdog Timer Timing

Table 14 lists the watchdog timer timing.

Table 14. Watchdog Timer Timing Parameters

No.	Characteristics	Expression	Min	Max	Unit
120	Delay from time-out to fall of \overline{WDT} , \overline{WDT}_1	$2 \times T_C$	10.0	—	ns
121	Delay from timer clear to rise of \overline{WDT} , \overline{WDT}_1	$2 \times T_C$	10.0	—	ns

2.18 Host Data Interface (HDI24) Timing

The HDI24 module is only on the DSP56721 device; the DSP56720 device does not have a HDI24 module. Also, only 16 bits of the HDI24 interface are pinned out on the DSP56721 device. Table 15 lists HDI24 timing and Figure 29 through Figure 35 show the timing diagrams.

Table 15. HDI24 Timing Parameters

No.	Characteristics ²	Expression	200 MHz		Unit
			Min	Max	
317	Read data strobe assertion width ³ HACK read assertion width	$T_C + 9.9$	14.9	—	ns
318	Read data strobe deassertion width ³ HACK read deassertion width	—	9.9	—	ns
319	Read data strobe deassertion width ³ after “Last Data Register” reads ^{4,5} , or between two consecutive CVR, ICR, or ISR reads ⁶ HACK deassertion width after “Last Data Register” reads ^{4,5}	$2 \times T_C + 6.6$	16.6	—	ns

Table 15. HDI24 Timing Parameters (Continued)

No.	Characteristics ²	Expression	200 MHz		Unit
			Min	Max	
320	Write data strobe assertion width ⁷ $\overline{\text{HACK}}$ write assertion width	—	13.2	—	ns
321	Write data strobe deassertion width ⁷ $\overline{\text{HACK}}$ write deassertion width • after ICR, CVR and “Last Data Register” writes ⁴	$2 \times T_C + 6.6$	16.6	—	ns
	• after IVR writes, or • after TXH:TXM writes (with HBE=0), or • after TXL:TXM writes (with HBE=1)	—	16.5	—	—
322	$\overline{\text{H\AA S}}$ assertion width	—	9.9	—	ns
323	$\overline{\text{H\AA S}}$ deassertion to data strobe assertion ⁸	—	0.0	—	ns
324	Host data input setup time before write data strobe deassertion ⁷ Host data input setup time before $\overline{\text{HACK}}$ write deassertion	—	9.9	—	ns
325	Host data input hold time after write data strobe deassertion ⁷ Host data input hold time after $\overline{\text{HACK}}$ write deassertion	—	3.3	—	ns
326	Read data strobe assertion to output data active from high impedance ³ $\overline{\text{HACK}}$ read assertion to output data active from high impedance	—	5.9	—	ns
327	Read data strobe assertion to output data valid ³ $\overline{\text{HACK}}$ read assertion to output data valid	—	—	29.6	ns
328	Read data strobe deassertion to output data high impedance ³ $\overline{\text{HACK}}$ read deassertion to output data high impedance	—	—	9.9	ns
329	Output data hold time after read data strobe deassertion ³ Output data hold time after $\overline{\text{HACK}}$ read deassertion	—	3.3	—	ns
330	$\overline{\text{HCS}}$ assertion to read data strobe deassertion ³	$T_C + 9.9$	14.9	—	ns
331	$\overline{\text{HCS}}$ assertion to write data strobe deassertion ⁷	—	9.9	—	ns
332	$\overline{\text{HCS}}$ assertion to output data valid	—	—	19.1	ns
333	$\overline{\text{HCS}}$ hold time after data strobe deassertion ⁸	—	0.0	—	ns
334	Address (AD7—AD0) setup time before $\overline{\text{H\AA S}}$ deassertion (HMUX=1)	—	4.7	—	ns
335	Address (AD7—AD0) hold time after $\overline{\text{H\AA S}}$ deassertion (HMUX=1)	—	3.3	—	ns
336	A10—A8 (HMUX ₈ =1), A2—A0 (HMUX=0), HR/ $\overline{\text{W}}$ setup time before data strobe assertion ⁸ • Read	—	0	—	ns
	• Write	—	4.7	—	
337	A10—A8 (HMUX=1), A2—A0 (HMUX=0), HR/ $\overline{\text{W}}$ hold time after data strobe deassertion ⁸	—	3.3	—	ns
338	Delay from read data strobe deassertion to host request assertion for “Last Data Register” read ^{3, 4, 9}	T_C	5.0	—	ns

Table 15. HDI24 Timing Parameters (Continued)

No.	Characteristics ²	Expression	200 MHz		Unit
			Min	Max	
339	Delay from write data strobe deassertion to host request assertion for “Last Data Register” write ^{4, 7, 9}	$2 \times T_C$	10.0	—	ns
340	Delay from data strobe assertion to host request deassertion for “Last Data Register” read or write (HROD = 0) ^{4, 8, 9}	—	—	19.1	ns
341	Delay from data strobe assertion to host request deassertion for “Last Data Register” read or write (HROD = 1, open drain Host Request) ^{4, 8, 9, 10}	—	—	300.0	ns
342	Delay from DMA \overline{HACK} deassertion to HOREQ assertion				ns
	• For “Last Data Register” read ⁴	$2 \times T_C + 19.1$	29.1	—	
	• For “Last Data Register” write ⁴	$1 \times T_C + 19.1$	24.1	—	
	• For other cases	—	0.0	—	
343	Delay from DMA \overline{HACK} assertion to HOREQ deassertion • HROD = 0 ⁴	—	—	20.2	ns
344	Delay from DMA \overline{HACK} assertion to HOREQ deassertion for “Last Data Register” read or write • HROD = 1, open drain Host Request ^{4, 10}	—	—	300.0	ns

Notes:

1. In the timing diagrams that follow, the controls pins are drawn as active low. The pin polarity is programmable.
2. $V_{CC} = 1.0 \text{ V} \pm 10\%$; $T_J = -40^\circ\text{C}$ to $+100^\circ\text{C}$; $C_L = 50 \text{ pF}$.
3. The read data strobe is HRD in the dual data strobe mode and HDS in the single data strobe mode.
4. The “last data register” is the register at address \$7, which is the last location to be read or written in data transfers.
5. This timing is applicable only if a read from the “last data register” is followed by a read from the RXL, RXM, or RXH registers without first polling RXDF or HREQ bits, or waiting for the assertion of the HOREQ signal.
6. This timing is applicable only if two consecutive reads from one of these registers are executed.
7. The write data strobe is HWR in the dual data strobe mode and HDS in the single data strobe mode.
8. The data strobe is host read (HRD) or host write (HWR) in the dual data strobe mode and host data strobe (HDS) in the single data strobe mode.
9. The host request is HOREQ in the single host request mode and HRRQ and HTRQ in the double host request mode.
10. In this calculation, the host request signal is pulled up by a 4.7 kW resistor in the open-drain mode.
11. HDI24_1 specs match those of HDI24.

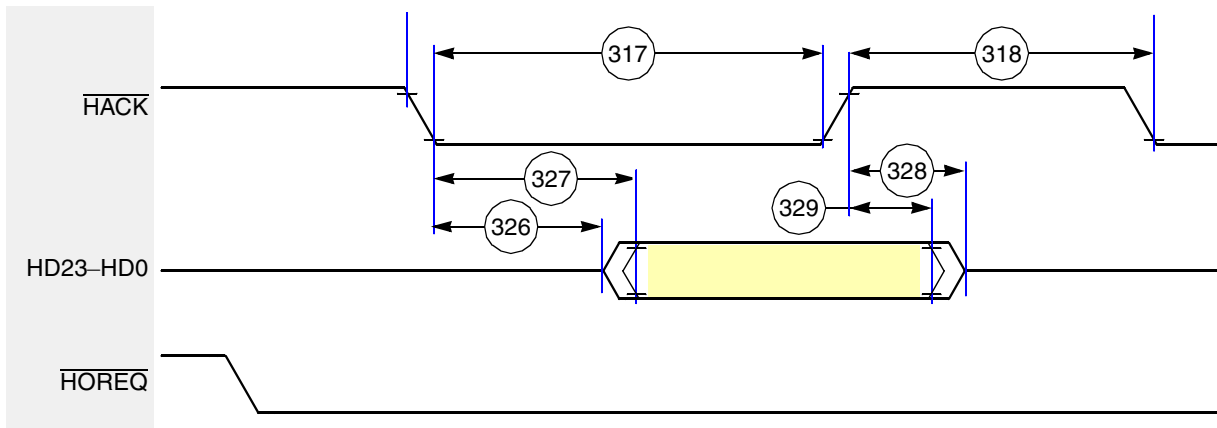

Figure 29. HDI24 Host Interrupt Vector Register (IVR) Read Timing Diagram

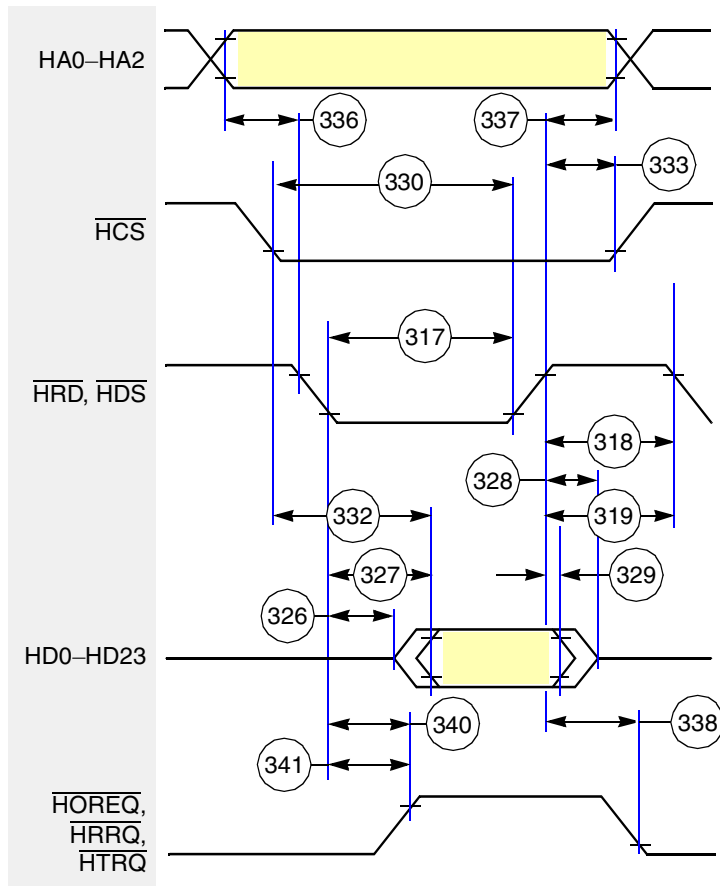

Figure 30. HDI24 Read Timing Diagram, Non-Multiplexed Bus

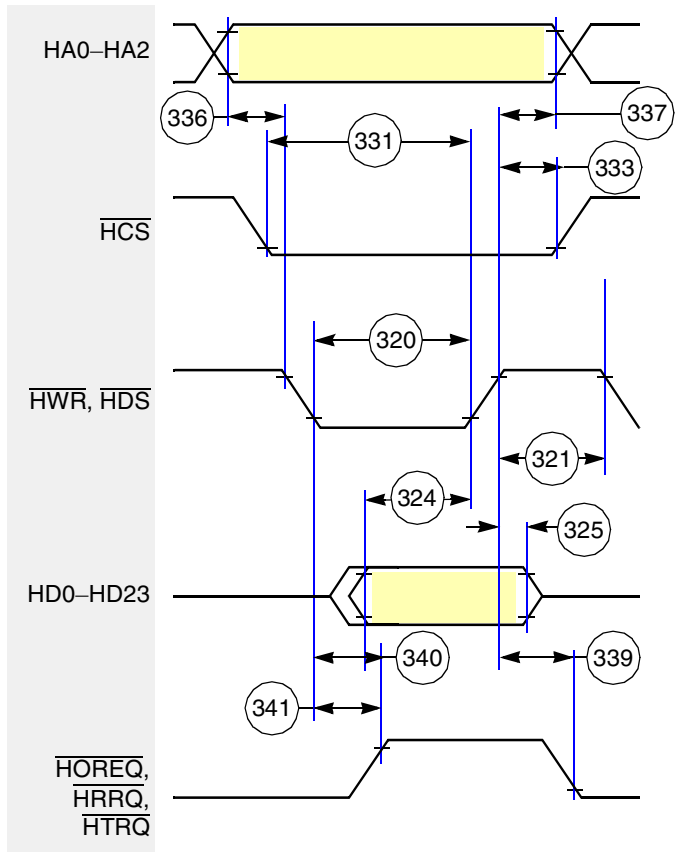

Figure 31. HDI24 Write Timing Diagram, Non-Multiplexed Bus

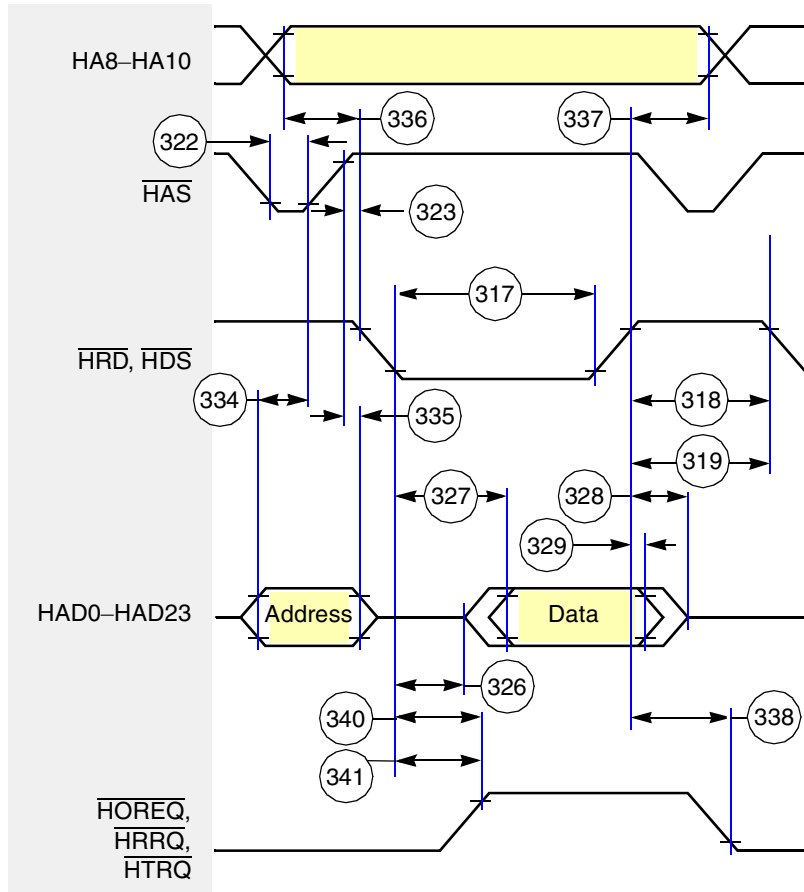

Figure 32. HDI24 Read Timing Diagram, Multiplexed Bus

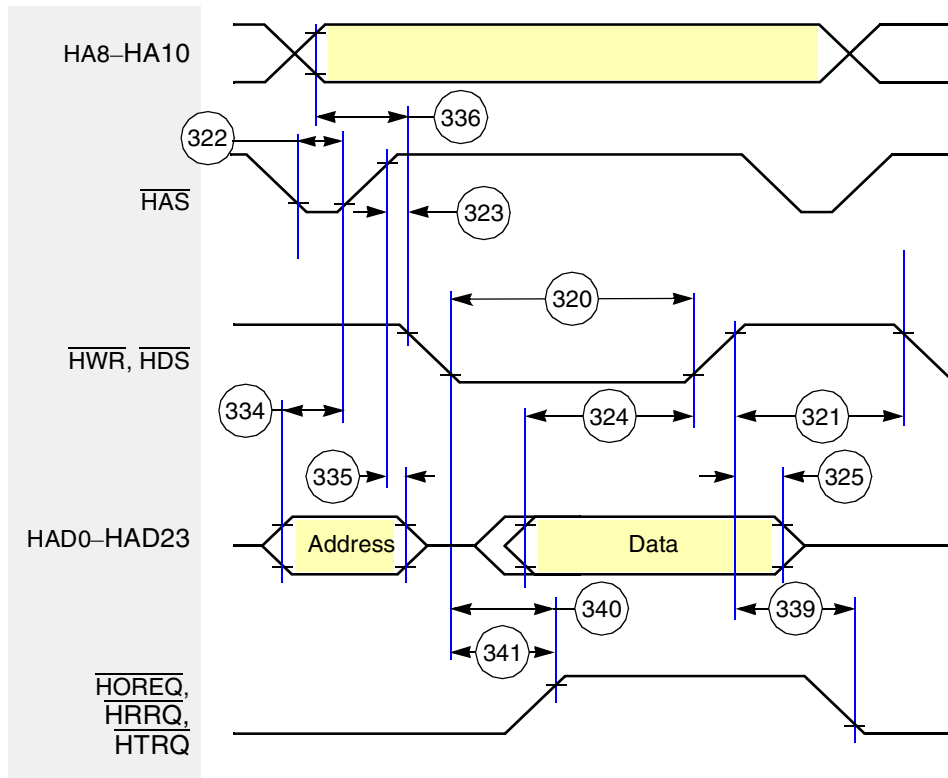

Figure 33. HDI24 Write Timing Diagram, Multiplexed Bus

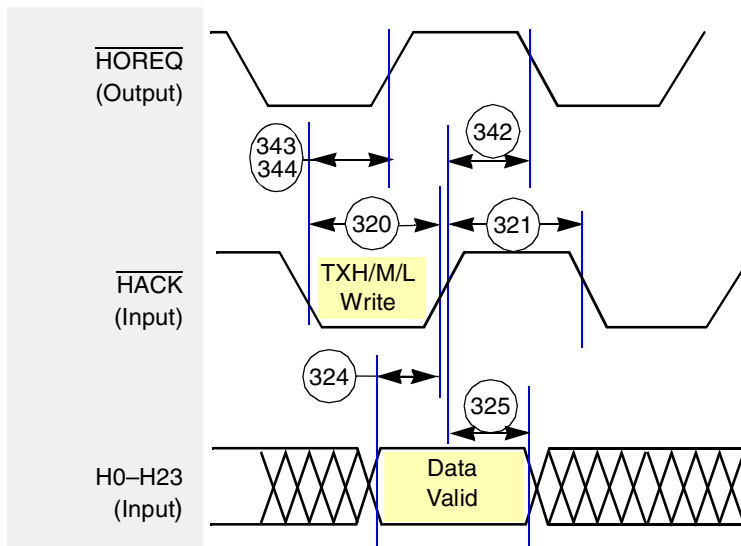

Figure 34. HDI24 Host DMA Write Timing Diagram

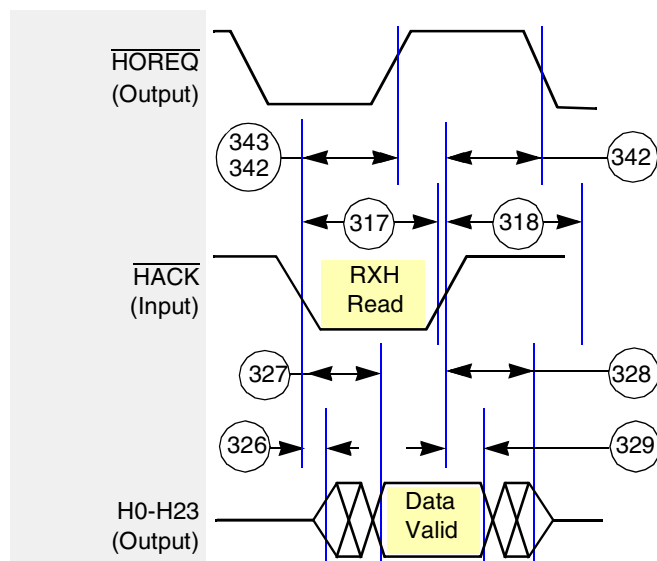

Figure 35. HDI24 Host DMA Read Timing Diagram

2.19 S/PDIF Timing

Table 16 lists the Sony/Philips Digital Interconnect Format (S/PDIF) timing parameters and Figure 36 and Figure 37 show the timing diagrams.

Table 16. S/PDIF Timing Parameters

Characteristics	Symbol	All Frequency		Unit
		Min	Max	
SPDIFIN1, SPDIFIN2, SPDIFIN3, SPDIFIN4 Skew: asynchronous inputs, no specs apply	—	—	0.7	ns
SPDIFOUT1, SPDIFOUT2 output (Load = 50 pf) • Skew • Transition Risng • Transition Falling	— — —	— — —	1.5 24.2 31.3	ns
SPDIFOUT1, SPDIFOUT2 output (Load = 30 pf) • Skew • Transition Risng • Transition Falling	— — —	— — —	1.5 13.6 18.0	ns
SRCK period	srckp	40.0	—	ns
SRCK high period	srckph	16.0	—	ns
SRCK low period	srckpl	16.0	—	ns
STCLK period	stclkp	40.0	—	ns
STCLK high period	stclkph	16.0	—	ns
STCLK low period	stclkpl	16.0	—	ns

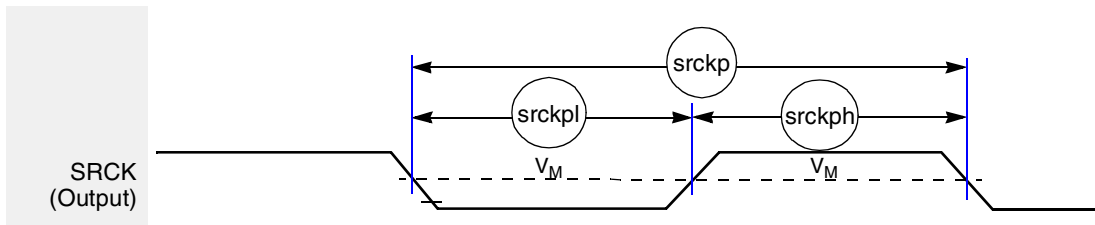

Figure 36. S/PDIF SRCK Timing Diagram

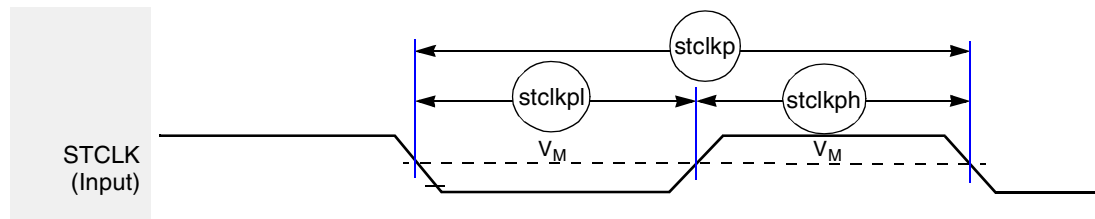

Figure 37. S/PDIF STCLK Timing Diagram

2.20 EMC Timing (DSP56720 Only)

The DSP56721 device does not have an EMC module. For EMC timing parameters in DSP56720 devices, see [Table 17](#), through [Table 19](#); for timing diagrams, see [Figure 38](#) through [Figure 40](#).

Table 17. EMC Timing Parameters (EMC PLL Enabled; LCRR[CLKDIV] = 2)

Parameter	Symbol	Min	Max	Unit
LCLK cycle time	T_{clk}	10	—	ns
LCLK skew to LSYNC_OUT	T_{clk_skew}	—	160	ps
Input setup to LSYNC_IN (except \overline{LGTA} /LUPWAIT)	T_{in_s}	3	—	ns
Input hold from LSYNC_IN (except \overline{LGTA} /LUPWAIT)	T_{in_h}	2	—	ns
\overline{LGTA} valid time	T_{gta}	12	—	ns
LUPWAIT valid time	T_{upwait}	12	—	ns
LALE negedge to LAD(address phase) invalid (address latch hold time)	T_{ale_h}	3	—	ns
LALE valid time	T_{ale}	3.8	—	ns
Output setup from LSYNC_IN (except LAD[23:0] and LALE)	T_{out_s}	4	—	ns
Output hold from LSYNC_IN (except LAD[23:0] and LALE)	T_{out_h}	2	—	ns
LAD[23:0] output setup from LSYNC_IN	T_{ad_s}	3.5	—	ns
LAD[23:0] output hold from LSYNC_IN	T_{ad_h}	1.5	—	ns
LSYNC_IN to output high impedance for LAD[23:0]	T_{ad_z}	—	4.3	ns

Chapter 22, “External Memory Controller (EMC),” in the *Symphony DSP56720/DSP56721 Multi-Core Audio Processors Reference Manual* explains in detail the interfacing and features of EMC. The applicable sections are as follows:

- Section 22.4.4.3, “UPM Signal Timing”
- Section 22.4.4.7, “Memory System Interface Example Using UPM”

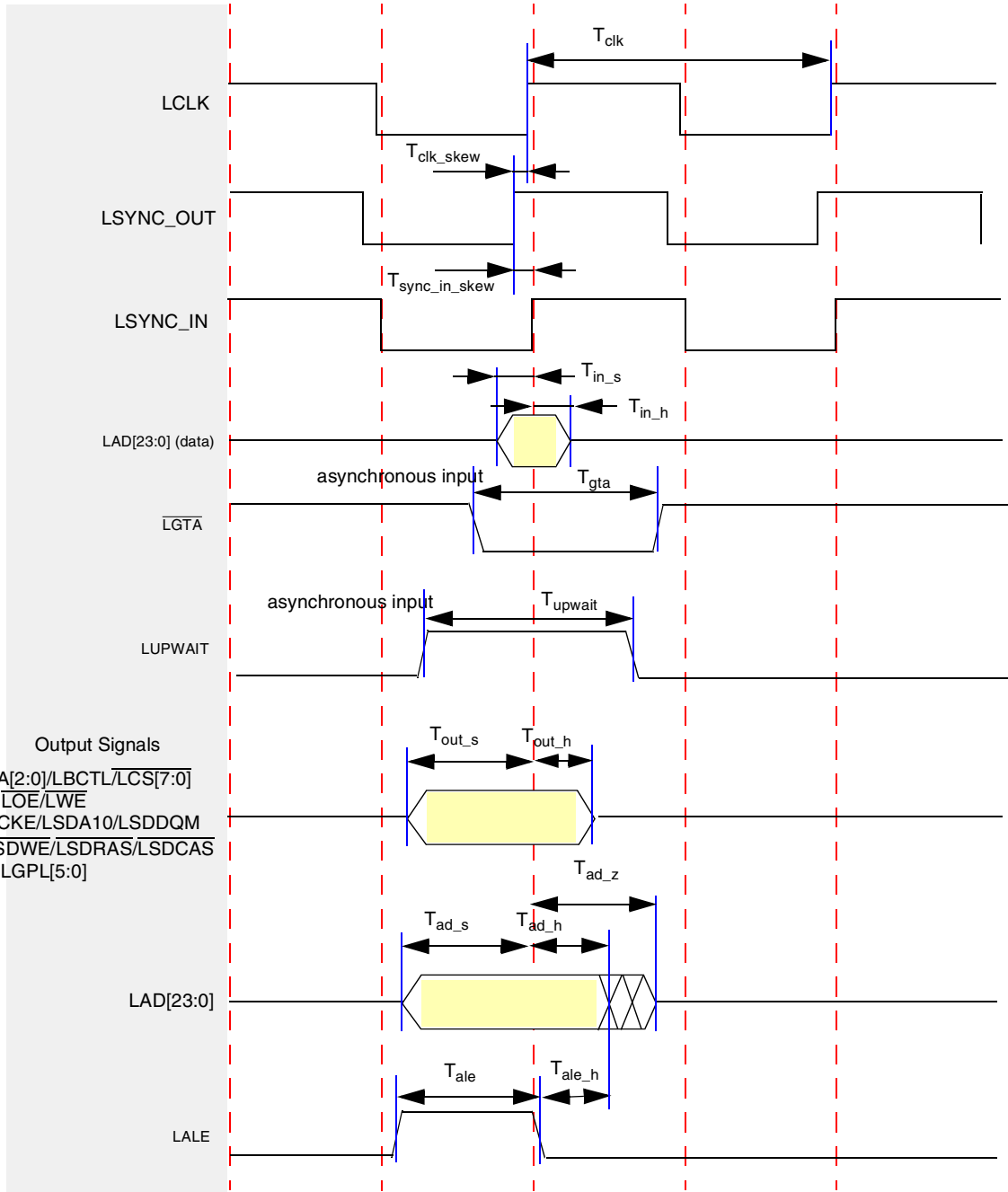

Figure 38. EMC Signals (EMC PLL Enabled; LCRR[CLKDIV] = 2)

Table 18. EMC Timing Parameters (EMC PLL Bypassed; LRCC[CLKDIV] = 4)

Parameter	Symbol	Min	Max	Unit
LCLK cycle time	T_{clk}	20	—	ns
Input setup to LCLK (except \overline{LGTA} /LUPWAIT)	T_{in_s}	8	—	ns
Input hold from LCLK (except \overline{LGTA} /LUPWAIT) ¹	T_{in_h}	-1	—	ns
\overline{LGTA} valid time	T_{gta}	22	—	ns
LUPWAIT valid time	T_{upwait}	22	—	ns
LALE negedge to LAD (address phase) invalid (address latch hold time)	T_{ale_h}	4	—	ns
LALE valid time	T_{ale}	14	—	ns
Output setup from LCLK (except LAD[23:0] and LALE)	T_{out_s}	9	—	ns
Output hold from LCLK (except LAD[23:0] and LALE)	T_{out_h}	8	—	ns
LAD[23:0] output setup from LCLK	T_{ad_s}	8	—	ns
LAD[23:0] output hold from LCLK	T_{ad_h}	7	—	ns
LCLK to output high impedance for LAD[23:0]	T_{ad_z}	—	8.1	ns

Notes:

1. A negative hold time means that the signal could be invalid before the LCLK rising edge.

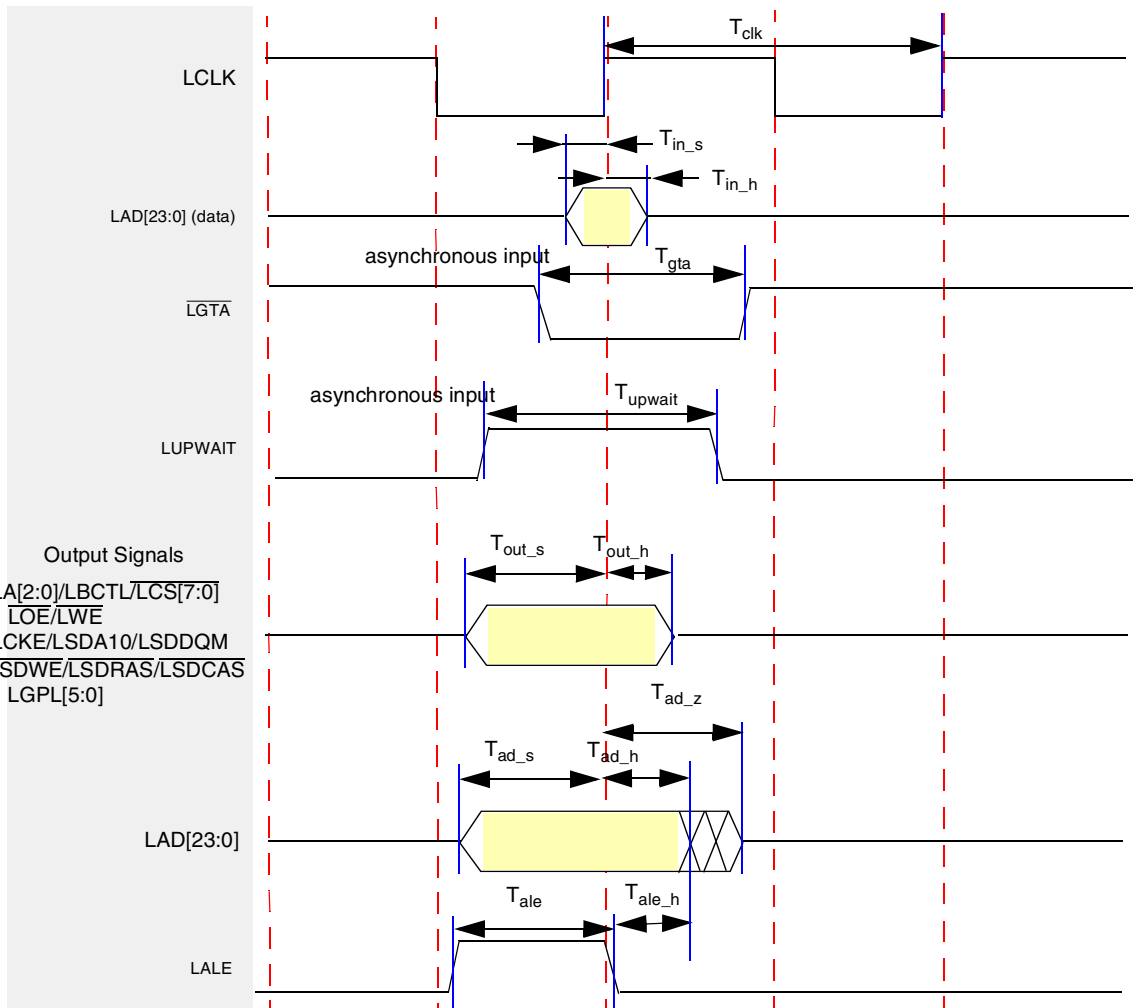

Figure 39. EMC Signals (EMC PLL Bypassed; LRCC[CLKDIV] = 4)

Table 19. EMC Timing Parameters (EMC PLL Bypassed; LRCC[CLKDIV] = 8)

Parameter	Symbol	Min	Max	Unit
LCLK cycle time	T_{clk}	40	—	ns
Input setup to LCLK (except \overline{LGTA} /LUPWAIT)	T_{in_s}	8	—	ns
Input hold from LCLK (except \overline{LGTA} /LUPWAIT) ¹	T_{in_h}	-1	—	ns
\overline{LGTA} valid time	T_{gta}	42	—	ns
LUPWAIT valid time	T_{upwait}	42	—	ns
LALE negedge to LAD (address phase) invalid (address latch hold time)	T_{ale_h}	5	—	ns
LALE valid time	T_{ale}	34	—	ns
Output setup from LCLK (except LAD[23:0] and LALE)	T_{out_s}	19	—	ns
Output hold from LCLK (except LAD[23:0] and LALE)	T_{out_h}	18	—	ns

Table 19. EMC Timing Parameters (EMC PLL Bypassed; LRCC[CLKDIV] = 8) (Continued)

Parameter	Symbol	Min	Max	Unit
LAD[23:0] output setup from LCLK	T_{ad_s}	12	—	ns
LAD[23:0] output hold from LCLK	T_{ad_h}	17	—	ns
LCLK to output high impedance for LAD[23:0]	T_{ad_z}	—	17.1	ns

Notes:

1. A negative hold time means that the signal could be invalid before the LCLK rising edge.

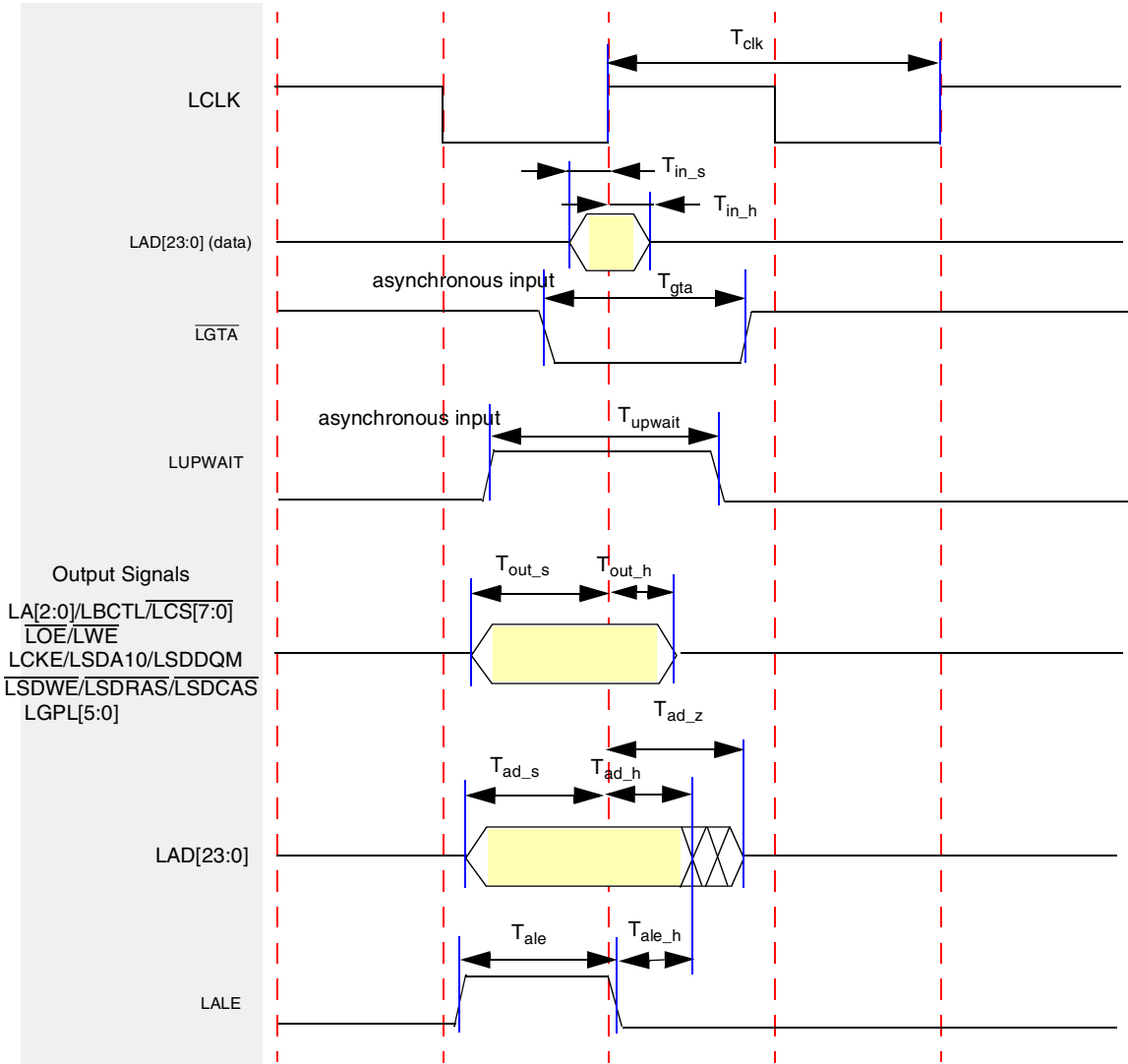

Figure 40. EMC Signals (EMC PLL Bypassed; LRCC[CLKDIV] = 8)

3 Functional Description and Application Information

See the *Symphony™ DSP56720/DSP56721 Multi-Core Audio Processors Reference Manual (DSP56720RM)* for detailed functional and applications information.

4 Ordering Information

Table 20 provides ordering information for both the DSP56720 and DSP56721.

Table 20. Ordering Information

Device	Device Marking	Ambient Temp.	LQFP Package
DSP56720 Commercial	DSPA56720AG	0°C–70°C	20 mm × 20 mm
	DSPB56720AG	0°C–70°C	20 mm × 20 mm
	DSPC56720AG	0°C–70°C	20 mm × 20 mm
DSP56720 Automotive	DSPA56720CAG	–40°C–85°C	20 mm × 20 mm
	DSPB56720CAG	–40°C–85°C	20 mm × 20 mm
	DSPC56720CAG	–40°C–85°C	20 mm × 20 mm
DSP56721 Commercial	DSPA56721AG	0°C–70°C	20 mm × 20 mm
	DSPB56721AG	0°C–70°C	20 mm × 20 mm
	DSPC56721AG	0°C–70°C	20 mm × 20 mm
	DSPA56721AF	0°C–70°C	14 mm × 14 mm
	DSPB56721AF	0°C–70°C	14 mm × 14 mm
	DSPC56721AF	0°C–70°C	14 mm × 14 mm
DSP56721 Automotive	DSPA56721CAG	–40°C–85°C	20 mm × 20 mm
	DSPB56721CAG	–40°C–85°C	20 mm × 20 mm
	DSPC56721CAG	–40°C–85°C	20 mm × 20 mm
	DSPA56721CAF	–40°C–85°C	14 mm × 14 mm
	DSPB56721CAF	–40°C–85°C	14 mm × 14 mm
	DSPC56721CAF	–40°C–85°C	14 mm × 14 mm

5 Package Information

For the outline drawings of available device packages, see Table 21 and sections 5.1–5.2.

Table 21. Package Outline Drawings

Device	Package	See
DSP56720	144-pin plastic LQFP	Figure 43 on page 51 and Figure 44 on page 52
DSP56721	80-pin plastic LQFP	Figure 43 on page 51 and Figure 42 on page 50
	144-pin plastic LQFP	Figure 43 on page 51 and Figure 44 on page 52

5.1 80-Pin Package Outline Drawing

Figure 41 and Figure 42 show the 80-pin package outline drawings.

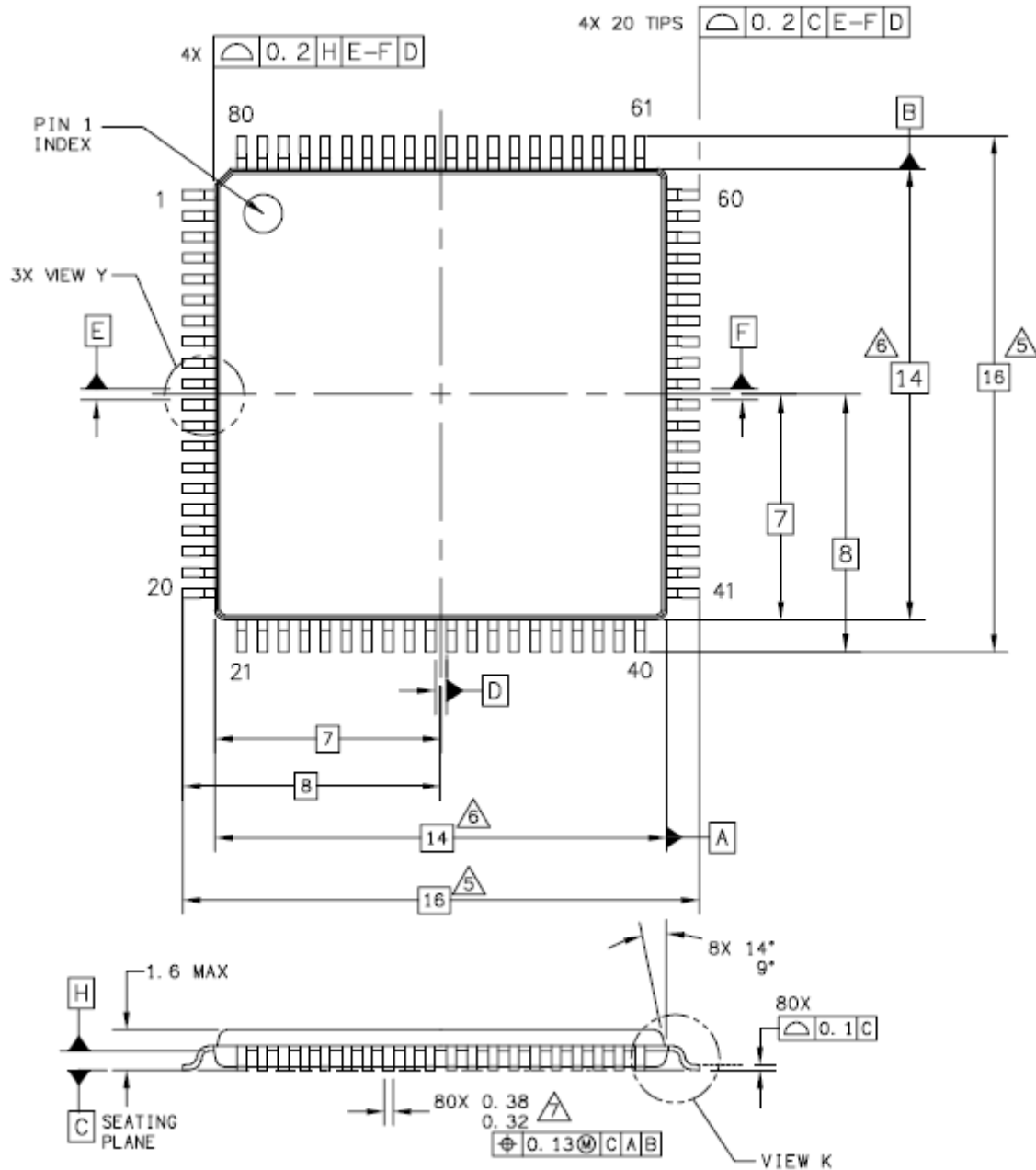

Figure 41. 80-Pin Package Outline Drawing (1 of 2)

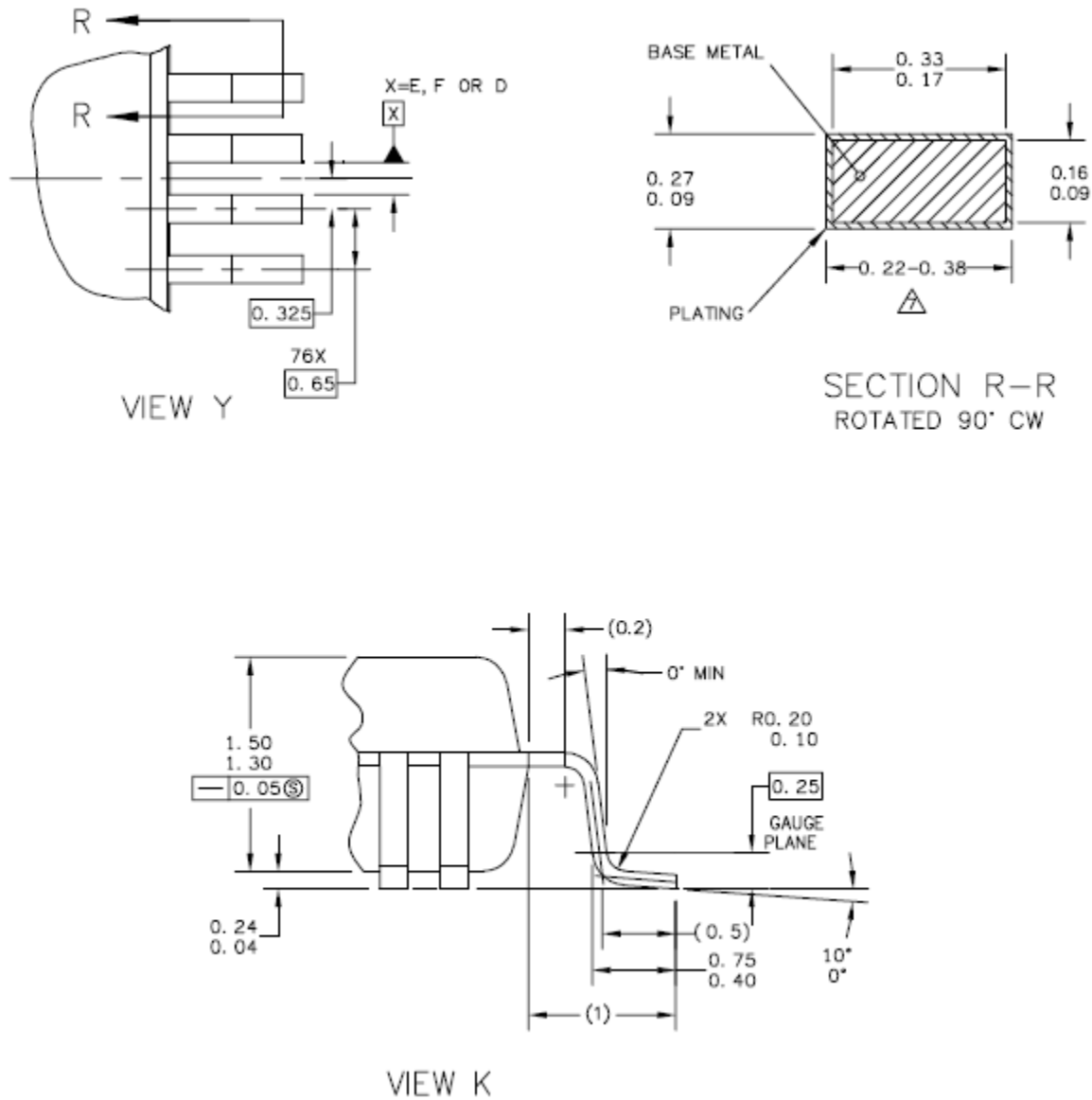

Figure 42. 80-Pin Package Outline Drawing (2 of 2)

NOTES

- 1 Dimensioning and tolerancing per asme Y14.5M-1994.
- 2 Controlling dimension: millimeter
- 3 Datum plane H is located at the bottom of lead and is coincident with the lead where the lead exits the plastic body at the bottom of the parting line.
- 4 Datum E, F and D to be determined at datum plane H.
- 5 Dimensions to be determined at seating plane C.
- 6 Dimensions do not include mold protrusion. Allowable protrusion is 0.25 mm per side. Dimensions include mold mismatch and are determined at datum plane H.
- 7 Dimension does not include dambar protrusion. Dambar protrusion shall not cause the lead width to exceed 0.46 mm. Minimum space between protrusion and adjacent lead or protrusion 0.07 mm.

5.2 144-Pin Package Outline Drawing

Figure 43 and Figure 44 show the 144-pin package drawings.

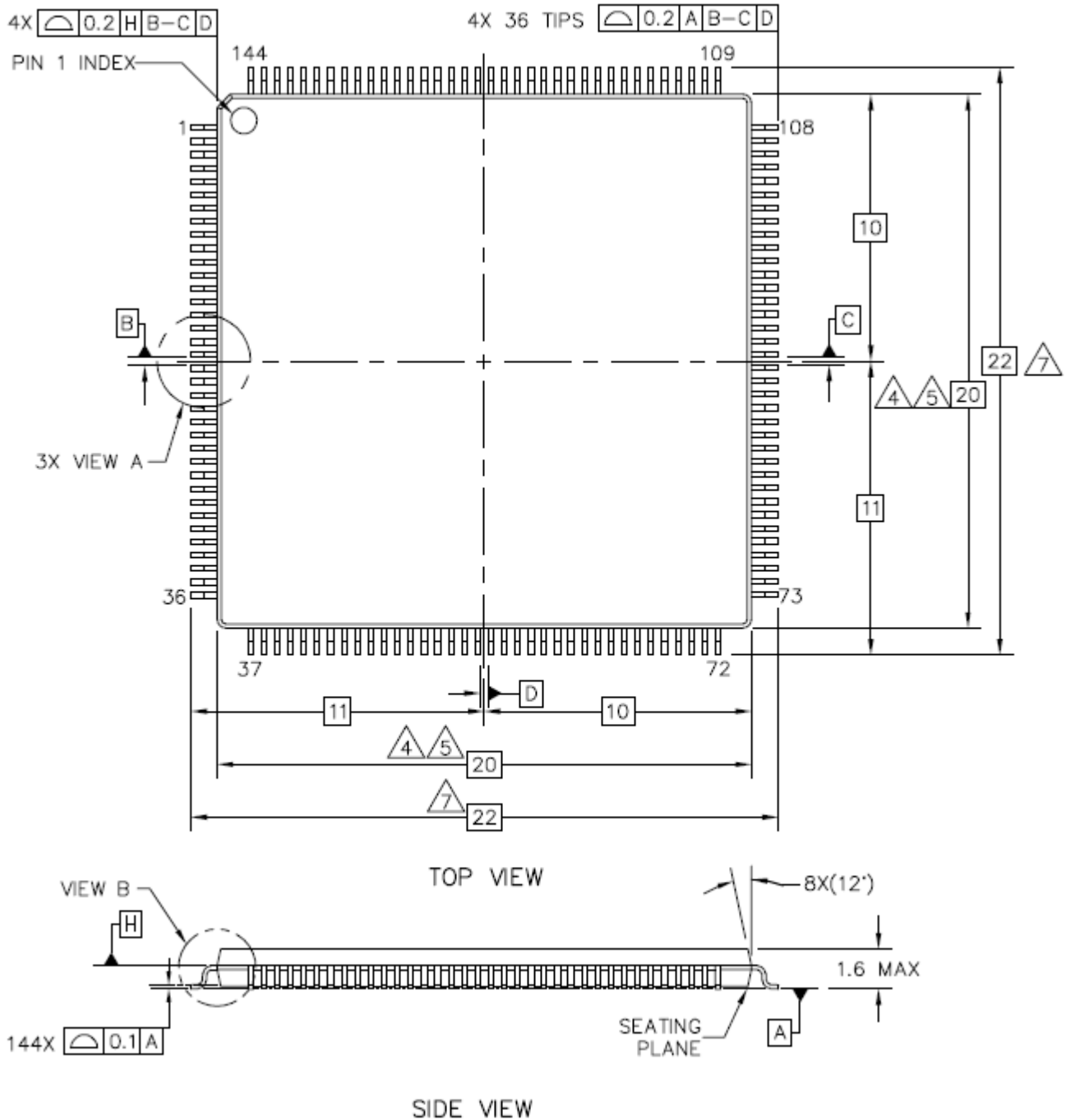

Figure 43. 144-Pin Package Outline Drawing (1 of 2)

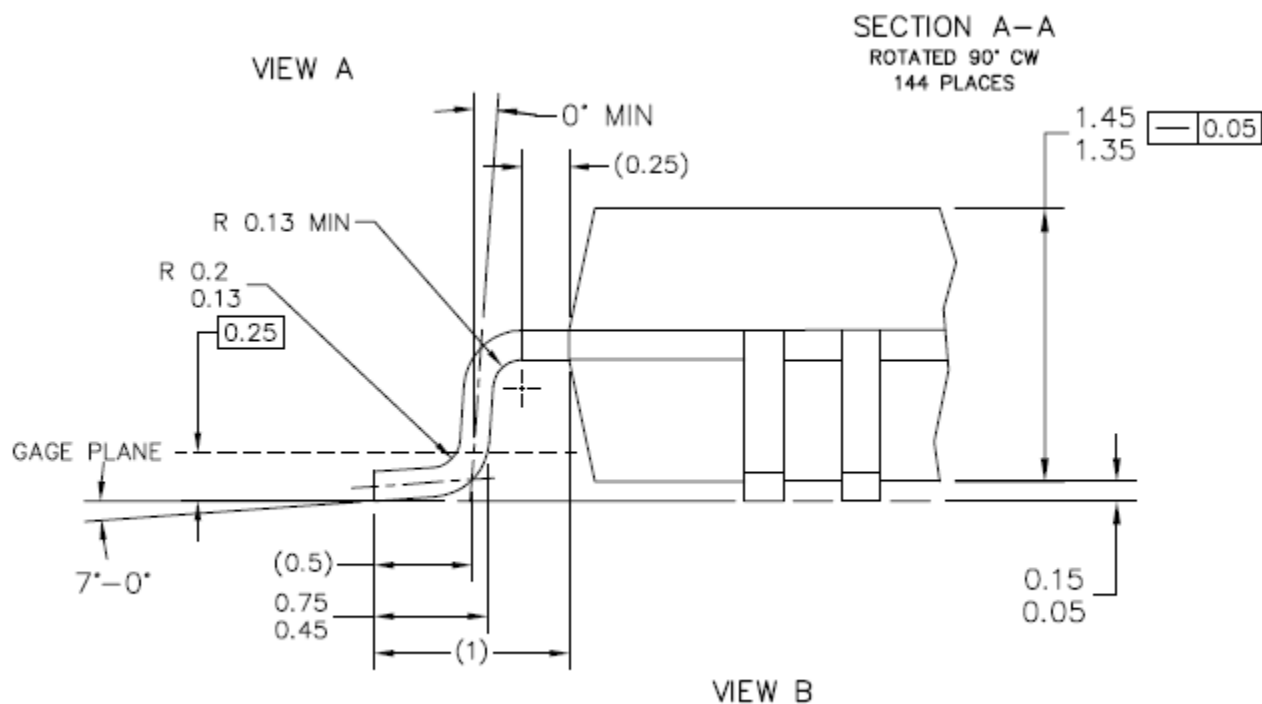
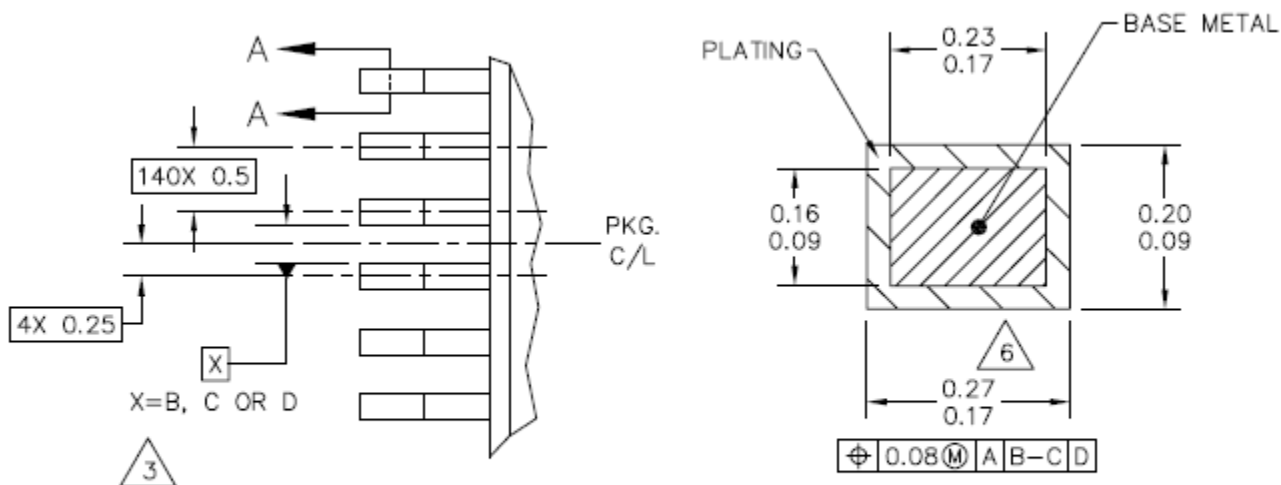

Figure 44. 144-Pin Package Outline Drawing (2 of 2)

NOTES

- 1 All dimensions are in millimeters
- 2 Interpret dimensions and tolerances per ASME Y14.5M-1994.
- 3 Datums B, C and D to be determined at datum plane H.
- 4 The top package body size may be smaller than the bottom package size by a maximum of 0.1 mm.
- 5 These dimensions do not include mold protrusions. The maximum allowable protrusion is 0.25 mm per side. These dimensions are maximum body size dimensions including mold mismatch.
- 6 This dimension does not include dambar protrusion. Protrusions shall not cause the lead width to exceed 0.35 mm minimum space between protrusion and an adjacent lead shall be 0.07 mm.

⁷ These dimensions are determined at the seating plane, datum A.

6 Product Documentation

This Data Sheet is labeled as a particular type: Product Preview, Advance Information, or Technical Data. Definitions of these types are available at: <http://www.freescale.com>. Documentation is available from a local Freescale Semiconductor, Inc. distributor, semiconductor sales office, Literature Distribution Center, or through the Freescale DSP home page on the Internet (the source for the latest information).

The following documents are required for a complete description of the device and are necessary to design properly with the parts:

DSP56300 Family Manual (document number DSP56300FM). Detailed description of the 56300-family architecture and the 24-bit core processor and instruction set.

Symphony™ DSP56720/DSP56721 Multi-Core Audio Processors Reference Manual (document number DSP56720RM). Detailed description of memory, peripherals, and interfaces.

DSP56720 Product Brief (DSP56720PB). Brief description of the DSP56720 device.

DSP56721 Product Brief (DSP56721PB). Brief description of the DSP56721 device.

7 Revision History

Table 22 summarizes revisions to this document.

Table 22. Revision History

Revision	Date	Description
5	02/2009	<ul style="list-style-type: none"> Updated values and added Commercial and Automotive columns in Table 4, “DC Electrical Characteristics.” Updated values in the following tables: Table 7, Table 9, Table 10, Table 11, Table 12, Table 13, Table 15, Table 17, Table 18, and Table 19. In Table 10, “Enhanced Serial Audio Interface Timing Parameters,” changed value for 87 to “13”. Added Section 2.4, “Power Consumption Considerations.” In Section 2.20, “EMC Timing (DSP56720 Only),” added text regarding the EMC chapter and applicable sections. Added automotive information to Table 20, “Ordering Information.”
4	04/2008	<ul style="list-style-type: none"> Added formula for thermal characteristics on page 10. Added values for pull-up and pull-down resistors on page 12.
3	03/2008	<ul style="list-style-type: none"> Updated order information on page 1 to include additional parts with temperature specification.
2	02/2008	<ul style="list-style-type: none"> Timing updates.
1	12/2007	<ul style="list-style-type: none"> Initial release

How to Reach Us:

Home Page:

www.freescale.com

Web Support:

<http://www.freescale.com/support>

USA/Europe or Locations Not Listed:

Freescale Semiconductor, Inc.
Technical Information Center, EL516
2100 East Elliot Road
Tempe, Arizona 85284
1-800-521-6274 or +1-480-768-2130
www.freescale.com/support

Europe, Middle East, and Africa:

Freescale Halbleiter Deutschland GmbH
Technical Information Center
Schatzbogen 7
81829 Muenchen, Germany
+44 1296 380 456 (English)
+46 8 52200080 (English)
+49 89 92103 559 (German)
+33 1 69 35 48 48 (French)
www.freescale.com/support

Japan:

Freescale Semiconductor Japan Ltd.
Headquarters
ARCO Tower 15F
1-8-1, Shimo-Meguro, Meguro-ku,
Tokyo 153-0064
Japan
0120 191014 or +81 3 5437 9125
support.japan@freescale.com

Asia/Pacific:

Freescale Semiconductor China Ltd.
Exchange Building 23F
No. 118 Jianguo Road
Chaoyang District
Beijing 100022
China
+86 10 5879 8000
support.asia@freescale.com

For Literature Requests Only:

Freescale Semiconductor Literature Distribution Center
P.O. Box 5405
Denver, Colorado 80217
1-800-441-2447 or 303-675-2140
Fax: 303-675-2150
LDCForFreescaleSemiconductor@hibbertgroup.com

Document Number: DSP56720EC

Rev. 5

02/2009

Information in this document is provided solely to enable system and software implementers to use Freescale Semiconductor products. There are no express or implied copyright licenses granted hereunder to design or fabricate any integrated circuits or integrated circuits based on the information in this document.

Freescale Semiconductor reserves the right to make changes without further notice to any products herein. Freescale Semiconductor makes no warranty, representation or guarantee regarding the suitability of its products for any particular purpose, nor does Freescale Semiconductor assume any liability arising out of the application or use of any product or circuit, and specifically disclaims any and all liability, including without limitation consequential or incidental damages. "Typical" parameters that may be provided in Freescale Semiconductor data sheets and/or specifications can and do vary in different applications and actual performance may vary over time. All operating parameters, including "Typicals", must be validated for each customer application by customer's technical experts. Freescale Semiconductor does not convey any license under its patent rights nor the rights of others. Freescale Semiconductor products are not designed, intended, or authorized for use as components in systems intended for surgical implant into the body, or other applications intended to support or sustain life, or for any other application in which the failure of the Freescale Semiconductor product could create a situation where personal injury or death may occur. Should Buyer purchase or use Freescale Semiconductor products for any such unintended or unauthorized application, Buyer shall indemnify and hold Freescale Semiconductor and its officers, employees, subsidiaries, affiliates, and distributors harmless against all claims, costs, damages, and expenses, and reasonable attorney fees arising out of, directly or indirectly, any claim of personal injury or death associated with such unintended or unauthorized use, even if such claim alleges that Freescale Semiconductor was negligent regarding the design or manufacture of the part.

RoHS-compliant and/or Pb-free versions of Freescale products have the functionality and electrical characteristics as their non-RoHS-compliant and/or non-Pb-free counterparts. For further information, see <http://www.freescale.com> or contact your Freescale sales representative.

For information on Freescale's Environmental Products program, go to <http://www.freescale.com/epp>.

Freescale™ and the Freescale logo are trademarks of Freescale Semiconductor, Inc. All other product or service names are the property of their respective owners.

© Freescale Semiconductor, Inc., 2009. All rights reserved.

