

To our customers,

Old Company Name in Catalogs and Other Documents

On April 1st, 2010, NEC Electronics Corporation merged with Renesas Technology Corporation, and Renesas Electronics Corporation took over all the business of both companies. Therefore, although the old company name remains in this document, it is a valid Renesas Electronics document. We appreciate your understanding.

Renesas Electronics website: <http://www.renesas.com>

April 1st, 2010
Renesas Electronics Corporation

Issued by: Renesas Electronics Corporation (<http://www.renesas.com>)

Send any inquiries to <http://www.renesas.com/inquiry>.

Not recommended
for new design

Notice

1. All information included in this document is current as of the date this document is issued. Such information, however, is subject to change without any prior notice. Before purchasing or using any Renesas Electronics products listed herein, please confirm the latest product information with a Renesas Electronics sales office. Also, please pay regular and careful attention to additional and different information to be disclosed by Renesas Electronics such as that disclosed through our website.
2. Renesas Electronics does not assume any liability for infringement of patents, copyrights, or other intellectual property rights of third parties by or arising from the use of Renesas Electronics products or technical information described in this document. No license, express, implied or otherwise, is granted hereby under any patents, copyrights or other intellectual property rights of Renesas Electronics or others.
3. You should not alter, modify, copy, or otherwise misappropriate any Renesas Electronics product, whether in whole or in part.
4. Descriptions of circuits, software and other related information in this document are provided only to illustrate the operation of semiconductor products and application examples. You are fully responsible for the incorporation of these circuits, software, and information in the design of your equipment. Renesas Electronics assumes no responsibility for any losses incurred by you or third parties arising from the use of these circuits, software, or information.
5. When exporting the products or technology described in this document, you should comply with the applicable export control laws and regulations and follow the procedures required by such laws and regulations. You should not use Renesas Electronics products or the technology described in this document for any purpose relating to military applications or use by the military, including but not limited to the development of weapons of mass destruction. Renesas Electronics products and technology may not be used for or incorporated into any products or systems whose manufacture, use, or sale is prohibited under any applicable domestic or foreign laws or regulations.
6. Renesas Electronics has used reasonable care in preparing the information included in this document, but Renesas Electronics does not warrant that such information is error free. Renesas Electronics assumes no liability whatsoever for any damages incurred by you resulting from errors in or omissions from the information included herein.
7. Renesas Electronics products are classified according to the following three quality grades: "Standard", "High Quality", and "Specific". The recommended applications for each Renesas Electronics product depends on the product's quality grade, as indicated below. You must check the quality grade of each Renesas Electronics product before using it in a particular application. You may not use any Renesas Electronics product for any application categorized as "Specific" without the prior written consent of Renesas Electronics. Further, you may not use any Renesas Electronics product for any application for which it is not intended without the prior written consent of Renesas Electronics. Renesas Electronics shall not be in any way liable for any damages or losses incurred by you or third parties arising from the use of any Renesas Electronics product for an application categorized as "Specific" or for which the product is not intended where you have failed to obtain the prior written consent of Renesas Electronics. The quality grade of each Renesas Electronics product is "Standard" unless otherwise expressly specified in a Renesas Electronics data sheets or data books, etc.
 - "Standard": Computers; office equipment; communications equipment; test and measurement equipment; audio and visual equipment; home electronic appliances; machine tools; personal electronic equipment; and industrial robots.
 - "High Quality": Transportation equipment (automobiles, trains, ships, etc.); traffic control systems; anti-disaster systems; anti-crime systems; safety equipment; and medical equipment not specifically designed for life support.
 - "Specific": Aircraft; aerospace equipment; submersible repeaters; nuclear reactor control systems; medical equipment or systems for life support (e.g. artificial life support devices or systems), surgical implantations, or healthcare intervention (e.g. excision, etc.), and any other applications or purposes that pose a direct threat to human life.
8. You should use the Renesas Electronics products described in this document within the range specified by Renesas Electronics, especially with respect to the maximum rating, operating supply voltage range, movement power voltage range, heat radiation characteristics, installation and other product characteristics. Renesas Electronics shall have no liability for malfunctions or damages arising out of the use of Renesas Electronics products beyond such specified ranges.
9. Although Renesas Electronics endeavors to improve the quality and reliability of its products, semiconductor products have specific characteristics such as the occurrence of failure at a certain rate and malfunctions under certain use conditions. Further, Renesas Electronics products are not subject to radiation resistance design. Please be sure to implement safety measures to guard them against the possibility of physical injury, and injury or damage caused by fire in the event of the failure of a Renesas Electronics product, such as safety design for hardware and software including but not limited to redundancy, fire control and malfunction prevention, appropriate treatment for aging degradation or any other appropriate measures. Because the evaluation of microcomputer software alone is very difficult, please evaluate the safety of the final products or system manufactured by you.
10. Please contact a Renesas Electronics sales office for details as to environmental matters such as the environmental compatibility of each Renesas Electronics product. Please use Renesas Electronics products in compliance with all applicable laws and regulations that regulate the inclusion or use of controlled substances, including without limitation, the EU RoHS Directive. Renesas Electronics assumes no liability for damages or losses occurring as a result of your noncompliance with applicable laws and regulations.
11. This document may not be reproduced or duplicated, in any form, in whole or in part, without prior written consent of Renesas Electronics.
12. Please contact a Renesas Electronics sales office if you have any questions regarding the information contained in this document or Renesas Electronics products, or if you have any other inquiries.

(Note 1) "Renesas Electronics" as used in this document means Renesas Electronics Corporation and also includes its majority-owned subsidiaries.

(Note 2) "Renesas Electronics product(s)" means any product developed or manufactured by or for Renesas Electronics.

HA12228F/HA12229F

Audio Signal Processor for Car Deck
(Decode only Dolby B-type NR* with PB Amp.)

REJ03F0134-0200
(Previous: ADE-207-325A)
Rev.2.00
Jun 15, 2005

Description

HA12228F/HA12229F are silicon monolithic bipolar IC providing Dolby noise reduction system*, music sensor, PB equalizer system in one chip.

Notes: 1. Dolby is a trademark of Dolby Laboratories Licensing Corporation.

A license from Dolby Laboratories Licensing Corporation is required for the use of this IC.

2. HA12229F is not built-in Dolby B-NR.

Functions

- PB equalizer × 2 channel
- Music sensor × 1 channel
- Dolby B-NR (Only HA12228F) × 2 channel
- Line mute SW × 2 channel

Features

- Different type of PB equalizer characteristics selection (120 μ s/70 μ s) is available with fully electronic control switching built-in.
- Easy interface with the PB head. (The PB-EQ resistance self-containing)
- Changeable to Forward, Reverse-mode for PB head with fully electronic control switching built-in.
- Available to change music sensing level by external resistor.
- Available to change response of music sensor by external capacitor.
- Music sensing level, built-in switch to change a band (MSG_V).
- NR ON/OFF fully electronic control switching built-in. (Only HA12228F)
- Line mute control switching built-in.
- Available to connect direct with MPU.
- These ICs are strong for a cellular phone noise.

Ordering Information

Operating Voltage

Product	Min	Max	Unit
HA12228F	6.5	12	V
HA12229F			

Note: 1. These ICs are designed to operate on single supply.

Standard Level

Product	Package Code (Previous Code)	PB-OUT Level
HA12228F	PLQP0040JB-A (FP-40B)	300 mVrms
HA12229F		

Function

Product	PB-EQ	Music Sensor	Mute	Dolby B-NR
HA12228F	<input type="radio"/>	<input type="radio"/>	<input type="radio"/>	<input type="radio"/>
HA12229F	<input type="radio"/>	<input type="radio"/>	<input type="radio"/>	<input checked="" type="radio"/>

Not recommend
for new design

Pin Description, Equivalent Circuit

(V_{CC} = 9 V single supply, T_a = 25°C, No Signal, The value in the table shows typical value.)

Pin No.	Terminal Name	Note	Equivalent Circuit	Description
13	MSI	V = V _{CC} /2		MS input * ¹
4	TAI(L)			Tape input
27	TAI(R)			
23 * ²	DET(R)	V = 2.5 V		Time constant pin for NR rectifier
8 * ²	DET(L)			Ripple filter
26	RIP	V = V _{CC} /2		
5 * ³	Bias	V = 0.28 V		Dolby bias current input
14	MSDET	—		Time constant pin for MS rectifier * ¹
25	PBOUT(R)	V = V _{CC} /2		PB output
6	PBOUT(L)			MS amp. output * ¹
12	MAOUT			
29	EQOUT(R)	V = V _{CC} /2		Equalizer output
2	EQOUT(L)			

- Notes: 1. MS: Music Sensor
 2. Non connection regarding HA12229F.
 3. Test pin regarding HA12229F. Usually open or pull down to GND with 18 kΩ.

Pin Description, Equivalent Circuit (cont.)

(V_{CC} = 9 V single supply, T_a = 25°C, No Signal, The value in the table shows typical value.)

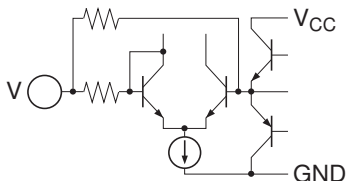
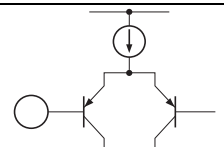
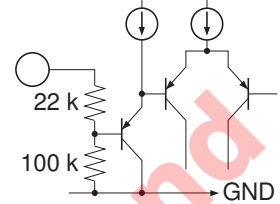
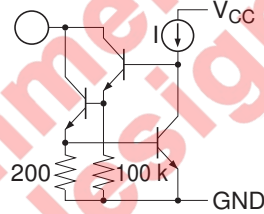
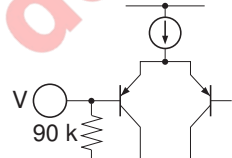
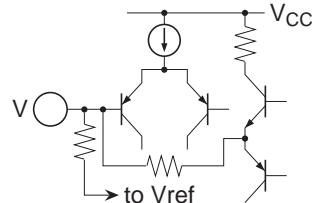
Pin No.	Terminal Name	Note	Equivalent Circuit	Description
30	M-OUT(R)	V = V _{CC} /2		Equalizer output for time constant
1	M-OUT(L)			
37	FIN(R)	—		Equalizer input (FORWARD)
39	FIN(L)			Equalizer input (REVERSE)
35	RIN(R)			
33	RIN(L)			
20	MUTE ON/OFF	—		Mode control input
21 * ¹	NR ON/OFF			
19	120/70			
17	F/R			
18	S/R(MS G _v)			
16	MSOUT	—		MS output (to MPU) * ²
10	MS G _v (S)	V = V _{CC} /2		MS gain terminal * ²
11	MS G _v (R)			
31	NFI(R)	V = V _{CC} /2		Equalizer output for time constant
40	NFI(L)			

Notes: 1. Non connection regarding HA12229F.

2. MS: Music Sensor

Pin Description, Equivalent Circuit (cont.)

($V_{CC} = 9\text{ V}$ single supply, $T_a = 25^\circ\text{C}$, No Signal, The value in the table shows typical value.)

Pin No.	Terminal Name	Note	Equivalent Circuit	Description
32	VREF1	$V = V_{CC}/2$		Reference output
38	VREF2			
28	VREF3			
3	VREF4			
15	V_{CC}	—		V_{CC} pin
36	GND	—		GND pin
7	NC	—		
9				
22				
24				
34				

Note: 1. R_{AL} : Parasitic metal resistance

Not recommended for new design

Block Diagram

HA12228F

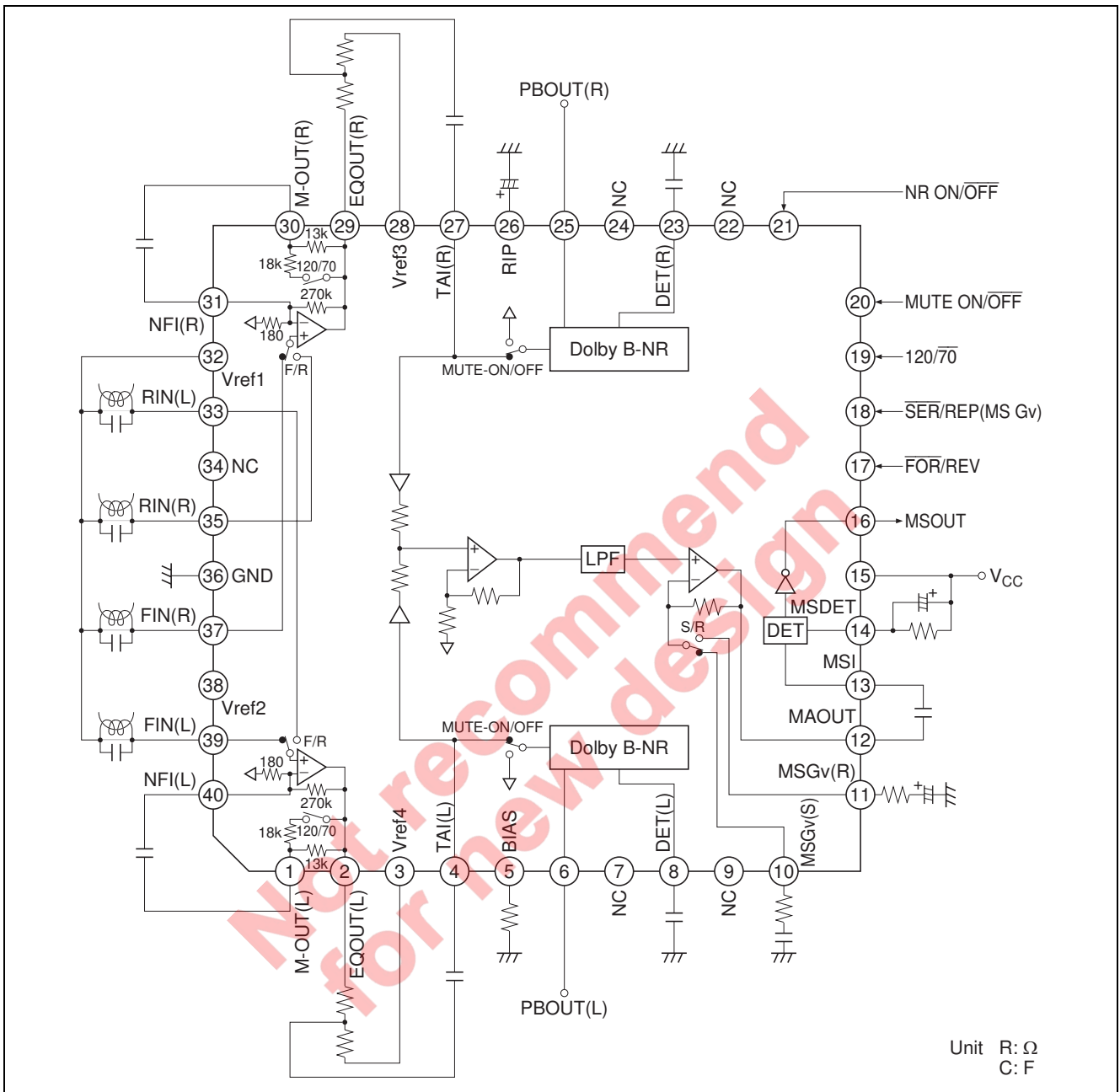

HA12229F

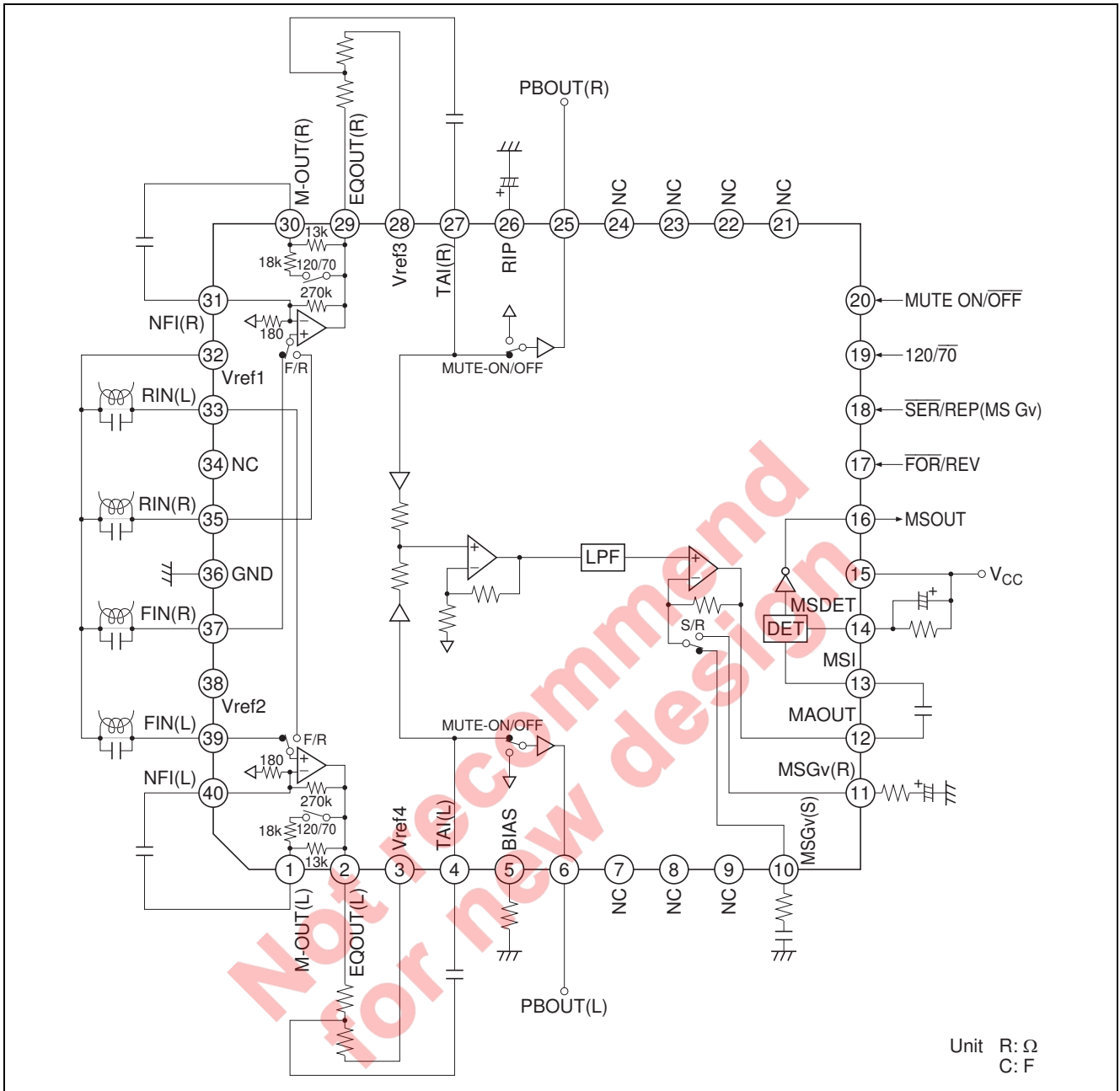

Functional Description

Power Supply Range

HA12228F/HA12229F are provided with three line output level, which will permit on optimum overload margin for power supply conditions. And these are designed to operate on single supply only.

Table 1 Supply Voltage Range

Product	Single Supply
HA12228F	6.5 V to 12.0 V
HA12229F	

Note: The lower limit of supply voltage depends on the line output reference level.

The minimum value of the overload margin is specified as 12 dB by Dolby Laboratories.

Reference Voltage

These devices provide the reference voltage of half the supply voltage that is the signal grounds. As the peculiarity of these devices, the capacitor for the ripple filter is very small about 1/100 compared with their usual value. The block diagram is shown as figure 1.

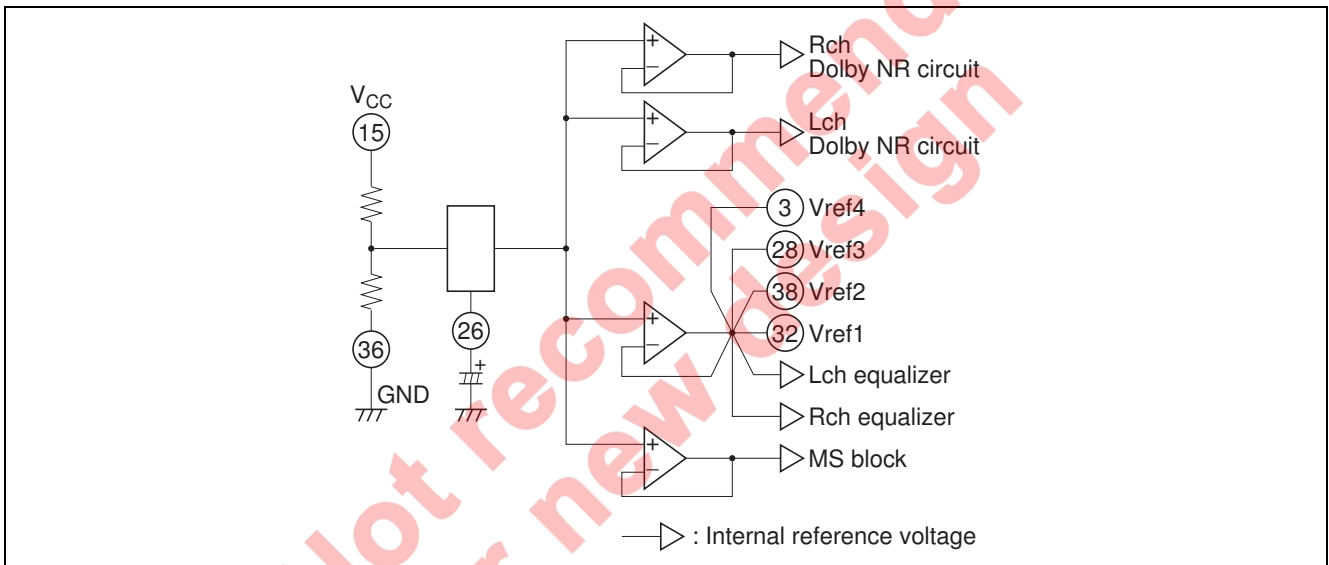

Figure 1a The HA12228F Block Diagram of Reference Supply Voltage

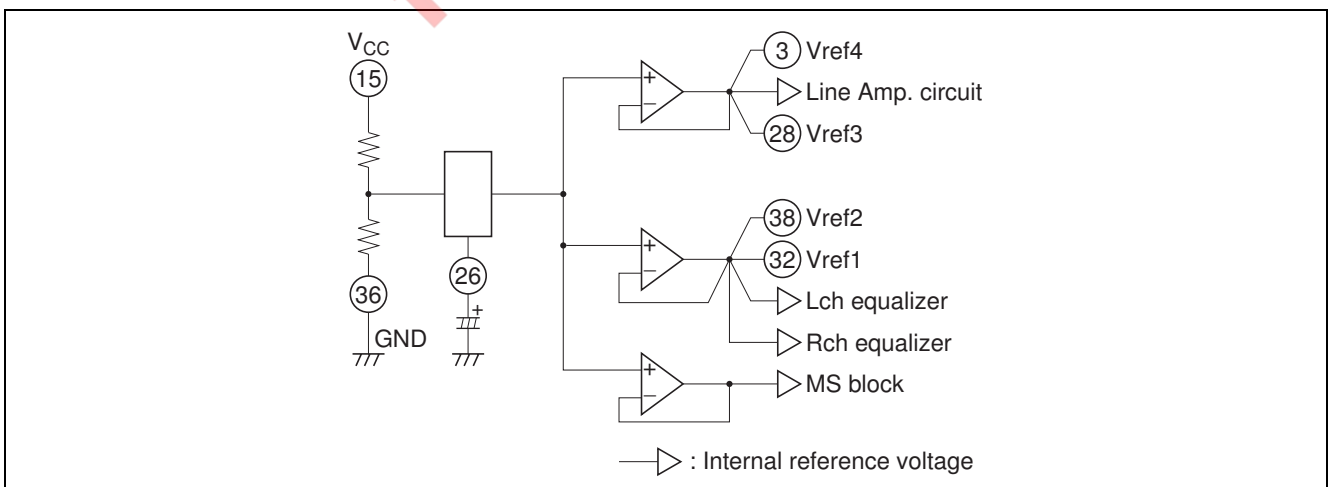

Figure 1b The HA12229F Block Diagram of Reference Supply Voltage

Operating Mode Control

HA12228F/HA12229F provides fully electronic switching circuits. And each operating mode control are controlled by parallel data (DC voltage).

When a power supply of this IC is cut off, for a voltage, in addition to a mode control terminal even though as do not destruct it, in series for resistance.

Table 2 Threshold Voltage (V_{TH})

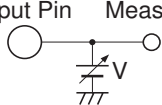
Pin No.	Lo	Hi	Unit	Test Condition
17, 18, 19, 20, 21*	-0.2 to 1.0	3.5 to V_{CC}	V	Input Pin Measure 

Note: * Non connection regarding HA12229F.

Table 3 Switching Truth Table

Pin No.	Pin Name	Lo	Hi
17	Forward/Reverse	Forward	Reverse
18	Search/Repeat	Search (FF or REV)	Repeat (Normal speed)
19	120 μ /70 μ	70 μ (Metal or Chrome)	120 μ (Normal)
20	MUTE ON/OFF	MUTE-OFF	MUTE-ON
21*	NR ON/OFF	NR-OFF	NR-ON

Notes: * Non connection regarding HA12229F.

- Each pins are on pulled down with 100 k Ω internal resistor. Therefore, it will be low-level when each pins are open.
- Over shoot level and under shoot level of input signal must be the standardized. (High: V_{CC} , Low: -0.2 V)
- Reducing pop noise is so much better for 10 k Ω to 22 k Ω resistor and 1 μ F to 22 μ F capacitor shown figure 2.

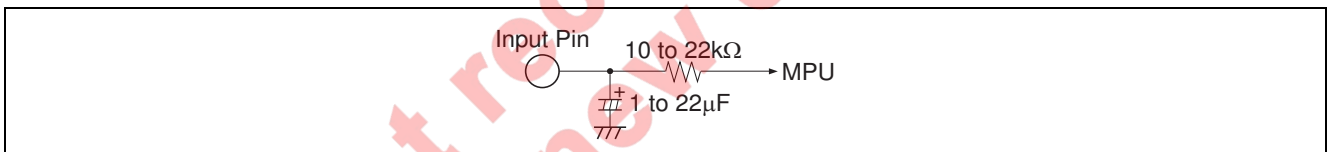

Figure 2 Interface for Reduction of Pop Noise

Input Block Diagram and Level Diagram

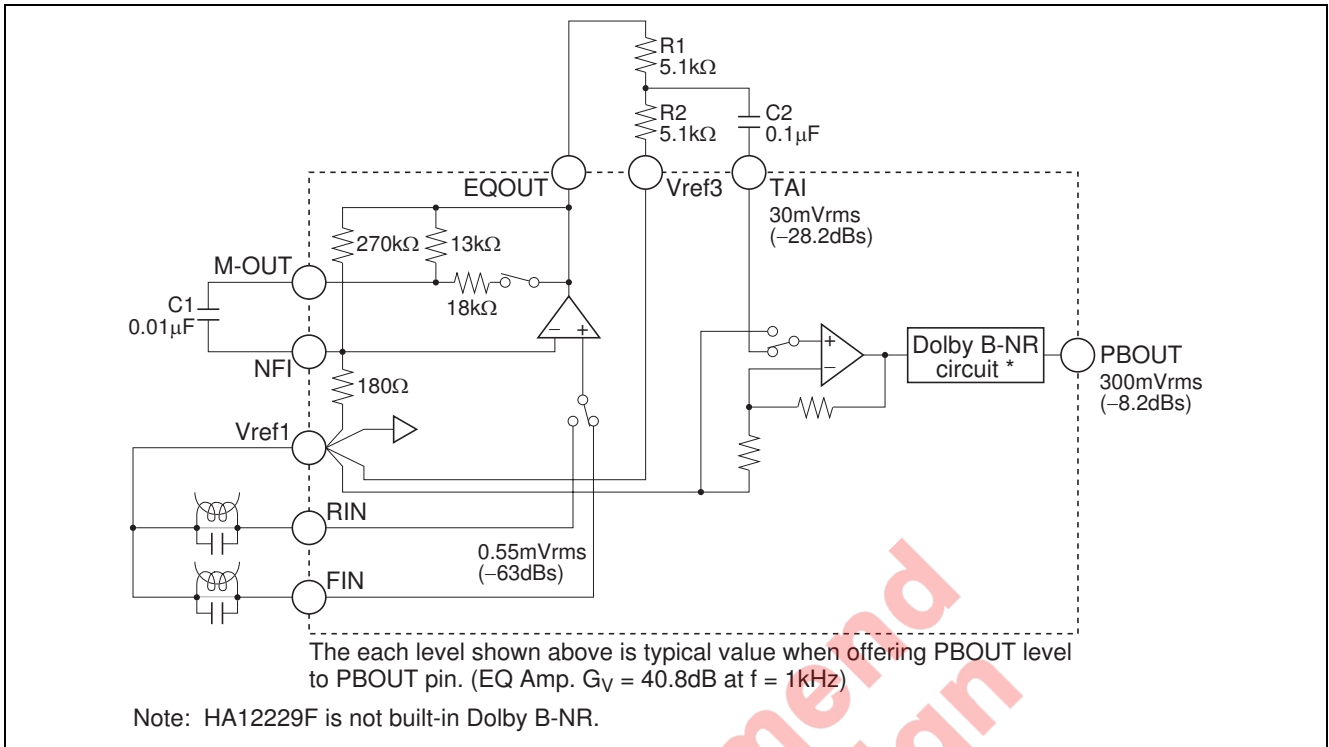

Figure 3 Input Block Diagram

Adjustment of Playback Dolby Level

After replace R5 and R6 with a half-fix volume of 10 kΩ, adjust playback Dolby level.

Not recommended for new design

The Sensitivity Adjustment of Music Sensor

Adjusting MS Amp. gain by external resistor, the sensitivity of music sensor can set up. The music sensor block diagram is shown in figure 4, and frequency response is shown in figure 5.

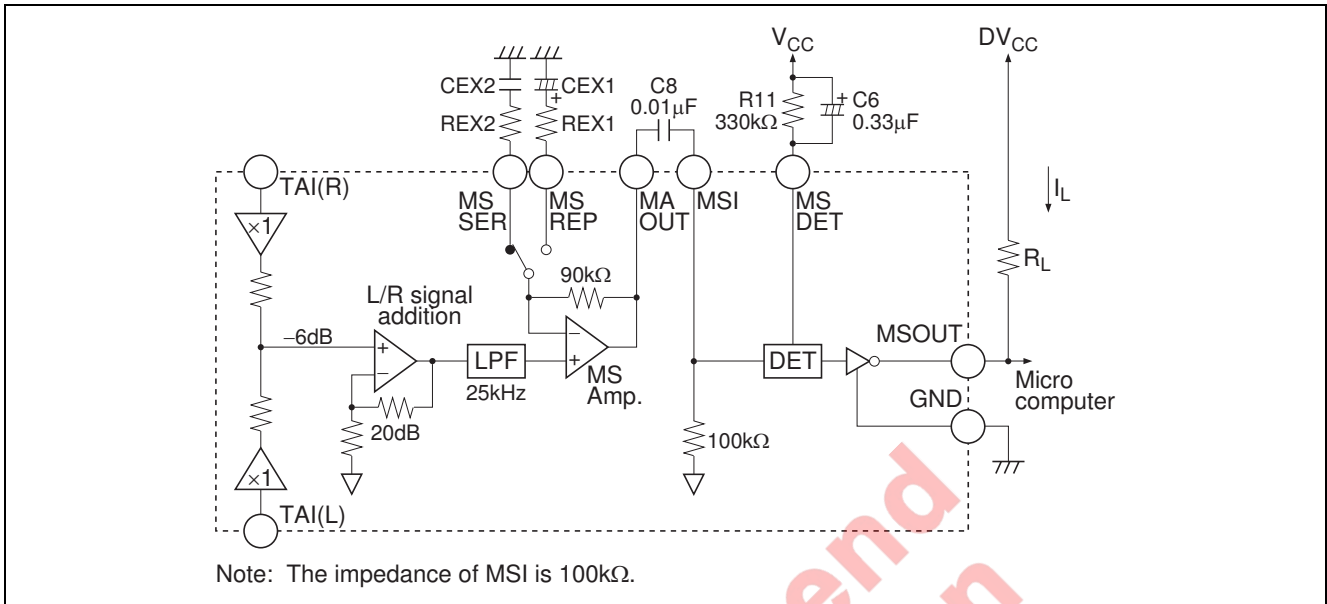

Figure 4 Music Sensor Block Diagram

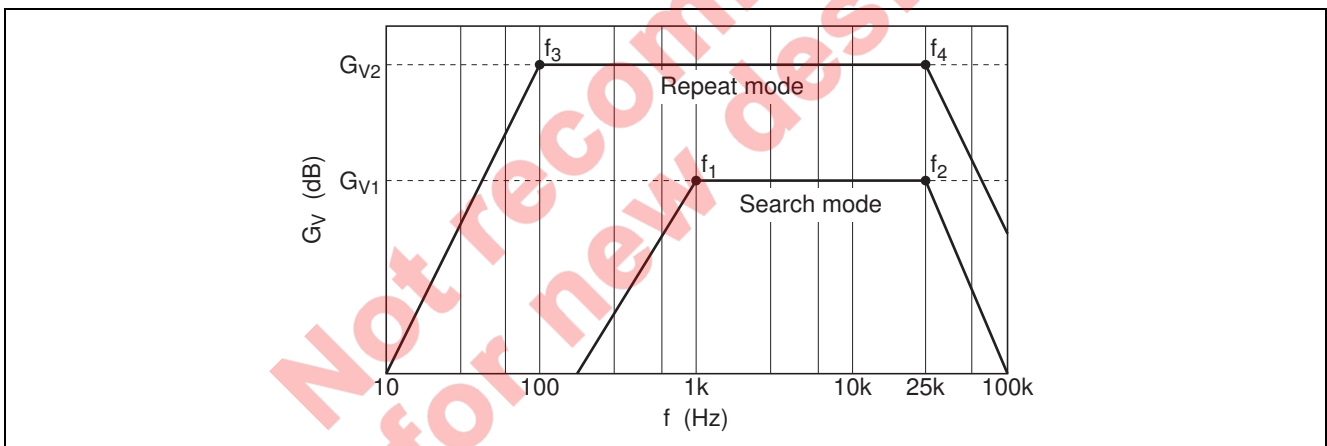

Figure 5 Frequency Response

1. Search mode

$$G_{V1} = 20\text{dB} + 20 \log \left(1 + \frac{90\text{k}}{\text{REX2}} \right) \text{ [dB]}$$

$$f_1 = \frac{1}{2\pi \cdot \text{CEX2} \cdot \text{REX2}} \text{ [Hz]}, f_2 = 25\text{k} \text{ [Hz]}$$

2. Repeat mode

$$G_{V2} = 20\text{dB} + 20 \log \left(1 + \frac{90\text{k}}{\text{REX1}} \right) \text{ [dB]}$$

$$f_3 = \frac{1}{2\pi \cdot \text{CEX1} \cdot \text{REX1}} \text{ [Hz]}, f_4 = 25\text{k} \text{ [Hz]}$$

G_{VIA} : L-R signal addition circuit gain.

The sensitivity of music sensor (S) is computed by the formula mentioned below.

$$S = - \left(G_V^{*1} - 20 \log \frac{130^{*3}}{30^{*2}} \right) = 12.7 - G_V \text{ [dB]}$$

- Notes: 1. Search mode: G_{V1} , Repeat mode: G_{V2}
 2. Standard level of TAI pin (Dolby level correspondence) = 30 mVrms
 3. Standard sensing level of music sensor = 130 mVrms

Item	REX1, 2	CEX1, 2	$G_{V1, 2}$	$f_{1, 3}$	$f_{2, 4}$	S (one side channel)	S (both channel)
Search mode	24 kΩ	0.01 μF	33.5 dB	663 Hz	25 kHz	-14.8 dB	-20.8 dB
Repeat mode	2.4 kΩ	1 μF	51.7 dB	66.3 Hz	25 kHz	-33.0 dB	-39.0 dB

Note: S is 6 dB down in case of one-side channel. And this MS presented hysteresis lest MSOUT terminal should turn over again High level or Low level, in case of thresh S level constantly.

Music Sensor Time Constant

- Sensing no signal to signal (Attack) is determined by C6, 0.01 μF to 1 μF capacitor C6 can be applicable.
- Sensing signal to no signal (Recovery) is determined by C6 and R11, however preceding (1), 100 kΩ to 1 MΩ can be applicable.

Music Sensor Output (MSOUT)

As for the internal circuit of music sensor block, music sensor output pin is connected to the collector of NPN type directly, therefore, output level will be “high” when sensing no signal. And output level will be “low” when sensing signal.

$$I_L = \frac{DV_{CC} - \text{MSOUT}_{LO}^*}{R_L}$$

* MSOUT_{LO} : Sensing signal (about 1V)

Note: 1. Supply voltage of MSOUT pin must be less than V_{CC} voltage.

The Tolerances of External Components for Dolby NR (Only HA12228F)

For adequate Dolby NR tracking response, take external components shown below.

Also, leak is small capacity, and please employ a good quality object.

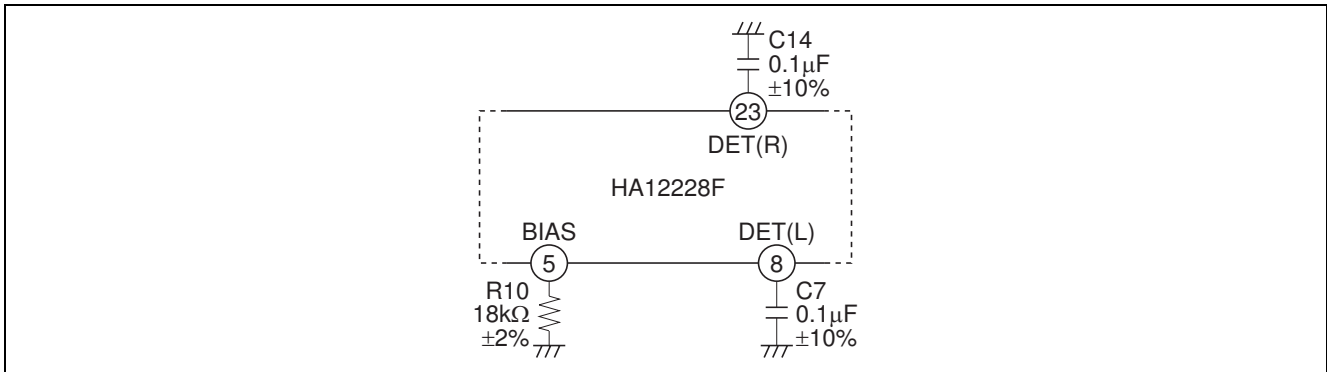

Figure 6 Tolerance of External Components

Countermeasure of a Cellular Phone Noise

This IC have reinforced a cellular phone noise countermeasure, to show it hereinafter.

However, it is presumed that this effect change it greatly, by a mount set.

Please sufficiently examine an arrangement of positions, shield method, wiring pattern, in order to obtain a maximum effect.

A high terminal of a noise sensitivity of this IC is FIN, RIN, NFI and RIP.

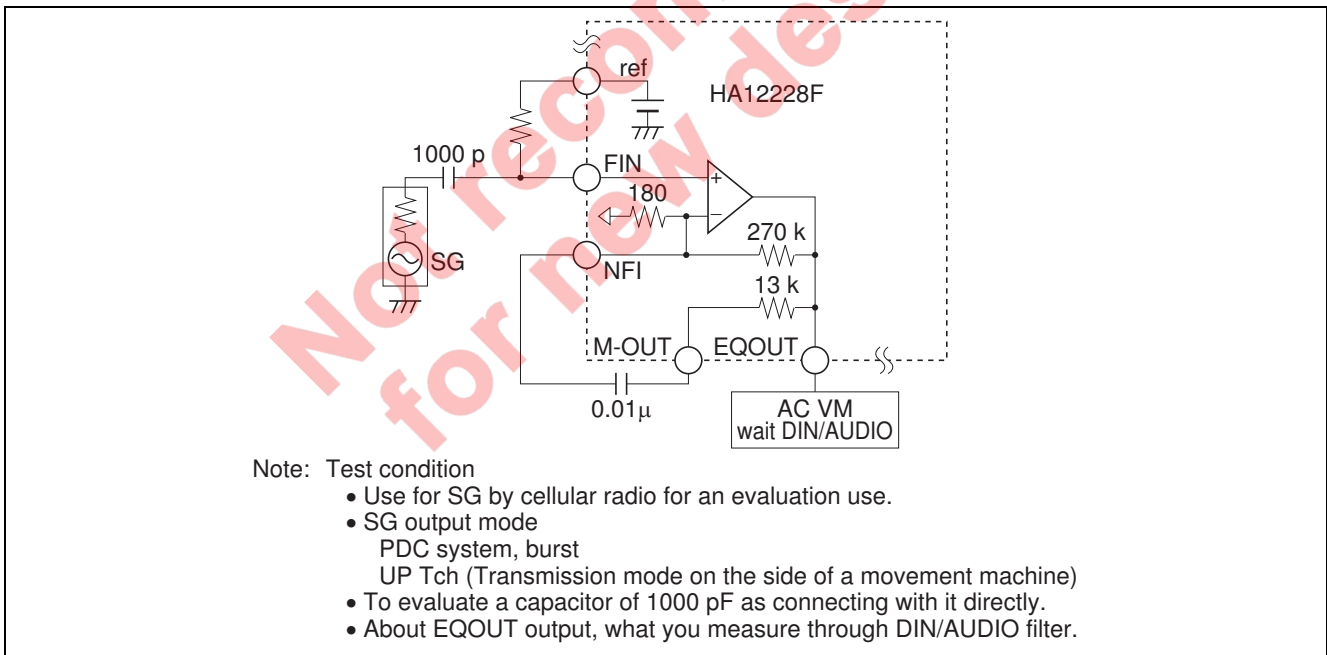

Figure 7 Test Circuit

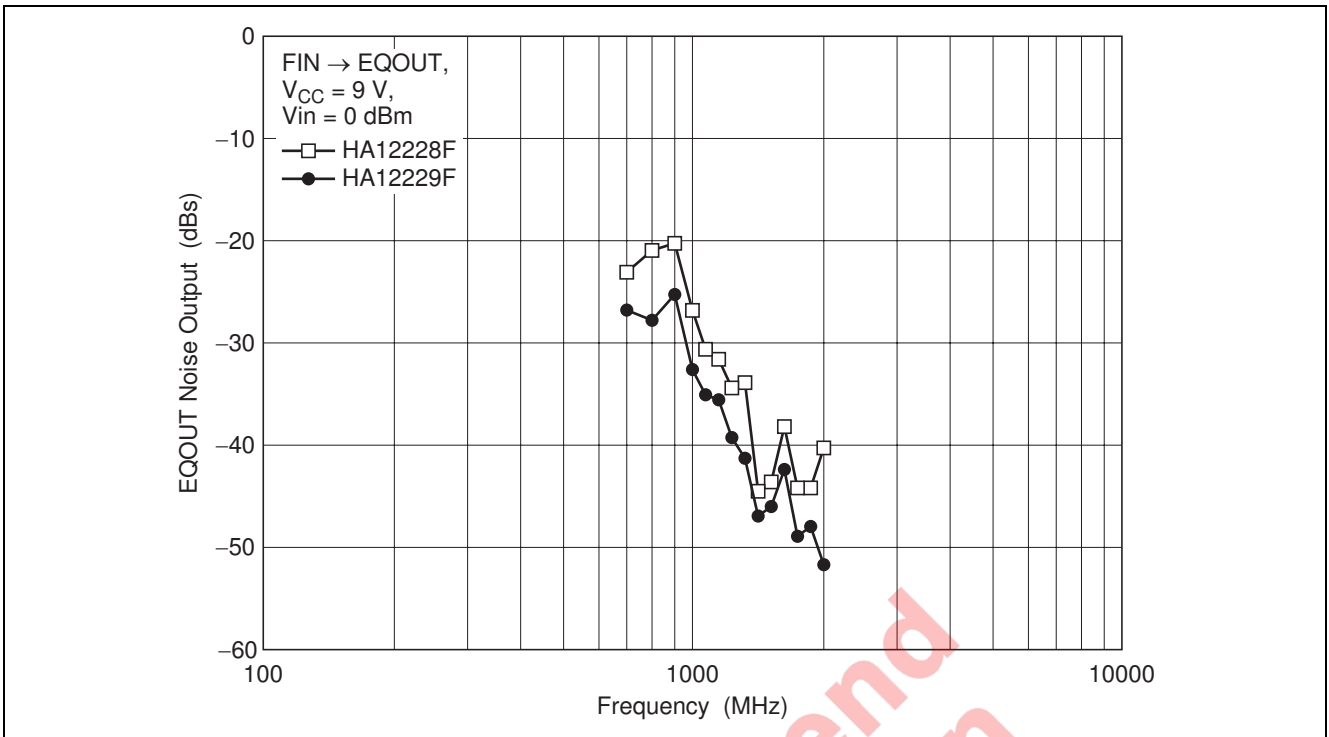

Figure 8 EQOUT Noise Output vs. Transmission Frequency Characteristic

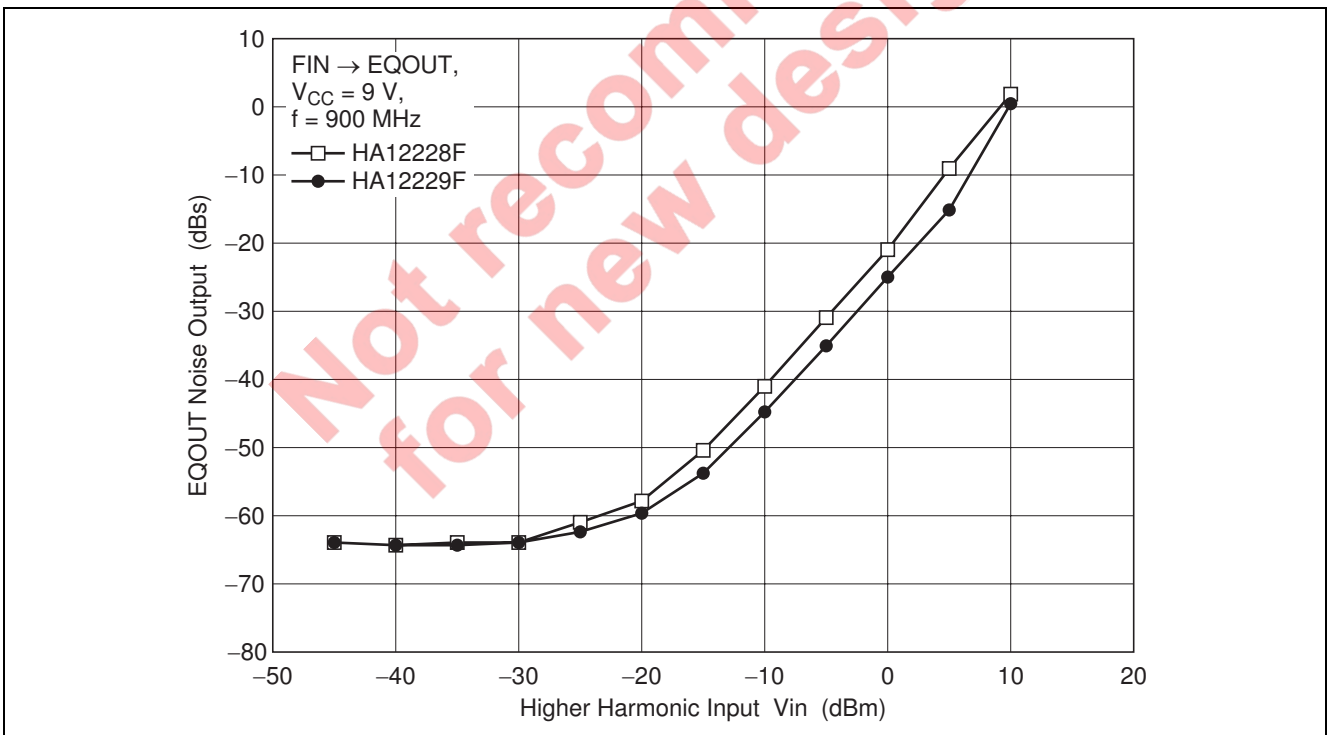

Figure 9 EQOUT Noise Output vs. Transmission Signal Input Level Characteristic

Absolute Maximum Ratings

(Ta = 25°C)

Item	Symbol	Rating	Unit	Note
Maximum supply voltage	V _{CC} Max	16	V	
Power dissipation	Pd	400	mW	Ta ≤ 85°C
Operating temperature	T _{opr}	-40 to +85	°C	
Storage temperature	T _{stg}	-55 to +125	°C	

Not recommend
for new design

Electrical Characteristics

HA12228F

(Ta = 25°C, V_{CC} = 9 V, Dolby level 0 dB = PBOUT level 0 dB = 300 mVrms, EQOUT level 0 dB = 60 mVrms)

Item	Symbol	Test Condition									Specification			Application Terminal					Remark	
		IC Condition									Min	Typ	Max	Input		Output				
		NR ON/OFF	MUTE ON/OFF	120μ/ 70μ	SER/ REP	FOR/ REV	f _{in} (Hz)	PBOUT level (dB)	EQOUT level (dB)	Other				Unit	R	L	R	L		COM
Quiescent current	I _Q	OFF	OFF	70μ	SER	FOR	—	—	—	No signal	4.0	9.5	15.0	mA	—	—	—	—	15	
Input Amp. gain	G _V IA	OFF	OFF	—	—	—	1k	0	—		19.0	20.0	21.0	dB	27	4	25	6		
B-type decode cut	DEC 2k (1)	ON	OFF	—	—	—	2k	-20	—		-5.8	-4.3	-2.8	dB	27	4	25	6		
	DEC 2k (2)	ON	OFF	—	—	—	2k	-30	—		-10.0	-8.5	-7.0	dB	27	4	25	6		
	DEC 5k (1)	ON	OFF	—	—	—	5k	-20	—		-4.7	-3.2	-1.7	dB	27	4	25	6		
	DEC 5k (2)	ON	OFF	—	—	—	5k	-30	—		-9.7	-8.2	-6.7	dB	27	4	25	6		
PBOUT offset	Vofs	OFF	OFF→ ON	—	—	—	—	—	—	No signal	-150	0	150	mV	—	—	25	6		1
Signal handling	V _o max	ON	OFF	—	—	—	1k	—	—	THD=1%	12.0	13.0	—	dB	27	4	25	6		2
Signal to noise ratio	S/N	ON	OFF	—	—	—	1k	(0)	—	Rg=10kΩ, CCIR/ARM	70.0	80.0	—	dB	27	4	25	6		
Total Harmonic Distortion	THD	ON	OFF	—	—	—	1k	0	—		—	0.05	0.3	%	27	4	25	6		
Channel separation	CTRL (1)	—	—	—	—	FOR	1k	—	(+20)		50.0	60.0	—	dB	37	39	29→2	2→29		
	CTRL (2)	OFF	OFF	—	—	—	1k	(+12)	—		70.0	80.0	—	dB	27	4	25→6	6→25		
MUTE attenuation	CT MUTE	OFF	OFF→ ON	—	—	—	1k	(+12)	—		70.0	80.0	—	dB	27	4	25	6		
PB-EQ gain	G _V EQ 1k	—	—	120μ	—	FOR/ REV	1k	—	0		37.8	40.8	43.8	dB	37/35	39/33	29	2		
	G _V EQ 10k(1)	—	—	120μ	—	FOR	10k	—	0		33.9	36.9	39.9	dB	37	39	29	2		
	G _V EQ 10k(2)	—	—	70μ	—	FOR	10k	—	0		29.6	32.6	35.6	dB	37	39	29	2		
PB-EQ Maximum output level	V _{OM}	—	—	120μ	—	FOR	1k	—	—	THD=1%	300	600	—	mVrms	37	39	29	2		
PB-EQ T.H.D.	THD-EQ	—	—	120μ	—	FOR/ REV	1k	—	+14dB		—	0.1	0.3	%	37/35	39/33	29	2		
PB-EQ input conversion noise	V _N	—	—	120μ	—	FOR/ REV	(1k)	—	—	Rg=680Ω, DIN-AUDIO	—	0.7	1.5	μVrms	37/35	39/33	29	2		
MS sensing level	V _{ON} (1)	OFF	OFF	—	SER	—	5k	—	—		-36.0	-32.0	-28.0	dB	27	4	25	6	16	3
	V _{ON} (2)	OFF	OFF	—	REP	—	5k	—	—		-18.0	-14.0	-10.0	dB	27	4	25	6	16	3
MS output low level	V _{OL}	OFF	OFF	—	SER	—	5k	0	—		—	1.0	1.5	V	27	4	—	—	16	
MS output leakage current	I _{OH}	—	—	—	—	—	—	—	—	No signal	—	0.0	2.0	μA	—	—	—	—	16	
Control voltage	V _{IL}	—	—	—	—	—	—	—	—		-0.2	—	1.0	V	—	—	—	—	17 to	
	V _{IH}	—	—	—	—	—	—	—	—		3.5	—	V _{CC}	V	—	—	—	—	21	

- Notes: 1. V_{CC} = 12V
 2. V_{CC} = 6.5V
 3. For inputting signal to one side channel

(Ta = 25°C, V_{CC} = 9 V, PBOU level 0 dB = 300 mVrms, EQOUT level 0 dB = 60 mVrms)

Item	Symbol	Test Condition										Specification			Application Terminal					Remark	
		IC Condition					Other					Min	Typ	Max	Unit	Input		Output			
		MUTE ON/OFF	120μ/ 70μ	SER/ REP	FOR/ REV	f _{in} (Hz)	PBOU level (dB)	EQOUT level (dB)	R	L	R					L	COM				
Quiescent current	I _Q	OFF	70μ	SER	FOR	—	—	—	—	—	No signal	3.0	5.0	8.0	mA	—	—	—	—	15	
Input Amp. gain	G _V IA	OFF	—	—	—	1k	0	—	—	—	—	19.0	20.0	21.0	dB	27	4	25	6		
PBOU offset	V _{ofs}	OFF→ ON	—	—	—	—	—	—	—	—	No signal	-150	0	150	mV	—	—	25	6		1
Signal handling	V _{o max}	OFF	—	—	—	1k	—	—	—	—	THD=1%	12.0	13.0	—	dB	27	4	25	6		2
Signal to noise ratio	S/N	OFF	—	—	—	1k	(0)	—	—	—	Rg=10kΩ, CCIR/ARM	70.0	80.0	—	dB	27	4	25	6		
Total Harmonic Distortion	THD	OFF	—	—	—	1k	0	—	—	—	—	—	0.05	0.3	%	27	4	25	6		
Channel separation	CTRL (1)	—	—	—	FOR	1k	—	(+20)	—	—	—	50.0	60.0	—	dB	37	39	29→2	2→29		
	CTRL (2)	OFF	—	—	—	1k	(+12)	—	—	—	—	70.0	80.0	—	dB	27	4	25→6	6→25		
MUTE attenuation	CT MUTE	OFF→ ON	—	—	—	1k	(+12)	—	—	—	—	70.0	80.0	—	dB	27	4	25	6		
PB-EQ gain	G _V EQ 1k	—	120μ	—	FOR/ REV	1k	—	0	—	—	—	37.8	40.8	43.8	dB	37/35	39/33	29	2		
	G _V EQ 10k(1)	—	120μ	—	FOR	10k	—	0	—	—	—	33.9	36.9	39.9	dB	37	39	29	2		
	G _V EQ 10k(2)	—	70μ	—	FOR	10k	—	0	—	—	—	29.6	32.6	35.6	dB	37	39	29	2		
PB-EQ Maximum output level	V _{OM}	—	120μ	—	FOR	1k	—	—	—	—	THD=1%	300	600	—	mVrms	37	39	29	2		
PB-EQ T.H.D.	THD-EQ	—	120μ	—	FOR/ REV	1k	—	+14dB	—	—	—	—	0.1	0.3	%	37/35	39/33	29	2		
PB-EQ input conversion noise	V _N	—	120μ	—	FOR/ REV	(1k)	—	—	—	—	Rg=680Ω, DIN-AUDIO	—	0.7	1.5	μVrms	37/35	39/33	29	2		
MS sensing level	V _{ON} (1)	OFF	—	SER	—	5k	—	—	—	—	—	-36.0	-32.0	-28.0	dB	27	4	25	6	16	3
	V _{ON} (2)	OFF	—	REP	—	5k	—	—	—	—	—	-18.0	-14.0	-10.0	dB	27	4	25	6	16	3
MS output low level	V _{OL}	OFF	—	SER	—	5k	0	—	—	—	—	—	1.0	1.5	V	27	4	—	—	16	
MS output leakage current	I _{OH}	—	—	—	—	—	—	—	—	—	No signal	—	0.0	2.0	μA	—	—	—	—	16	
Control voltage	V _{IL}	—	—	—	—	—	—	—	—	—	—	-0.2	—	1.0	V	—	—	—	—	17 to 20	
	V _{IH}	—	—	—	—	—	—	—	—	—	—	3.5	—	V _{CC}	V	—	—	—	—		

- Notes: 1. V_{CC} = 12V
2. V_{CC} = 6.5V
3. For inputting signal to one side channel

Test Circuit

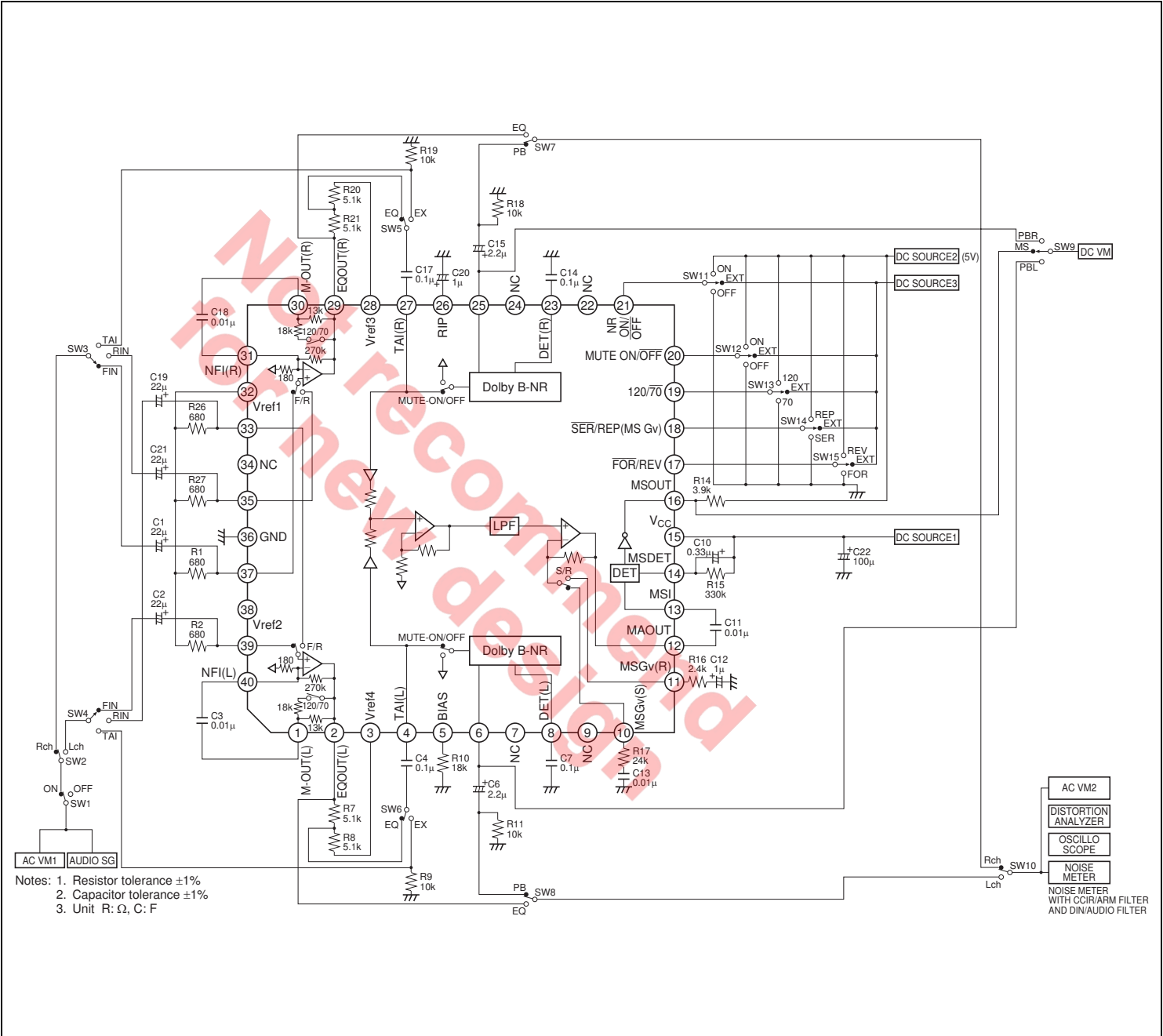

Characteristic Curves

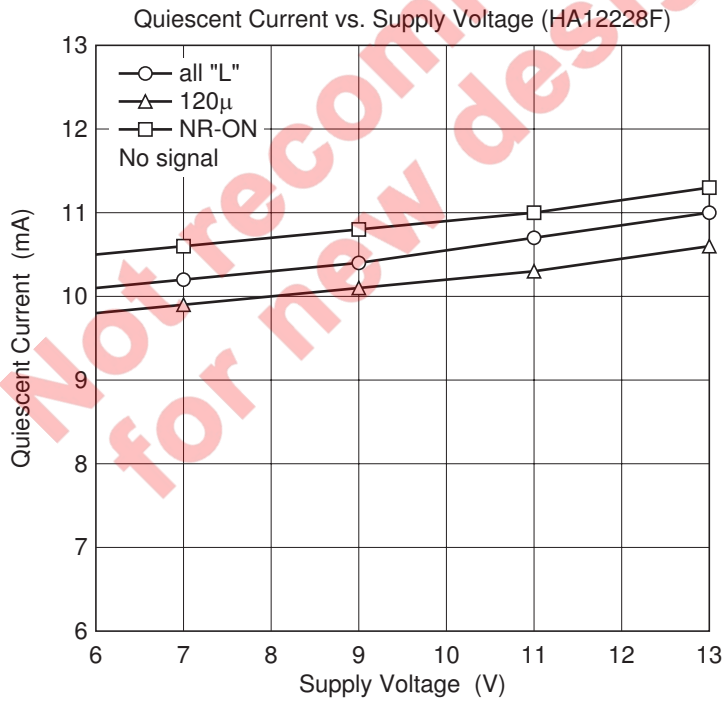
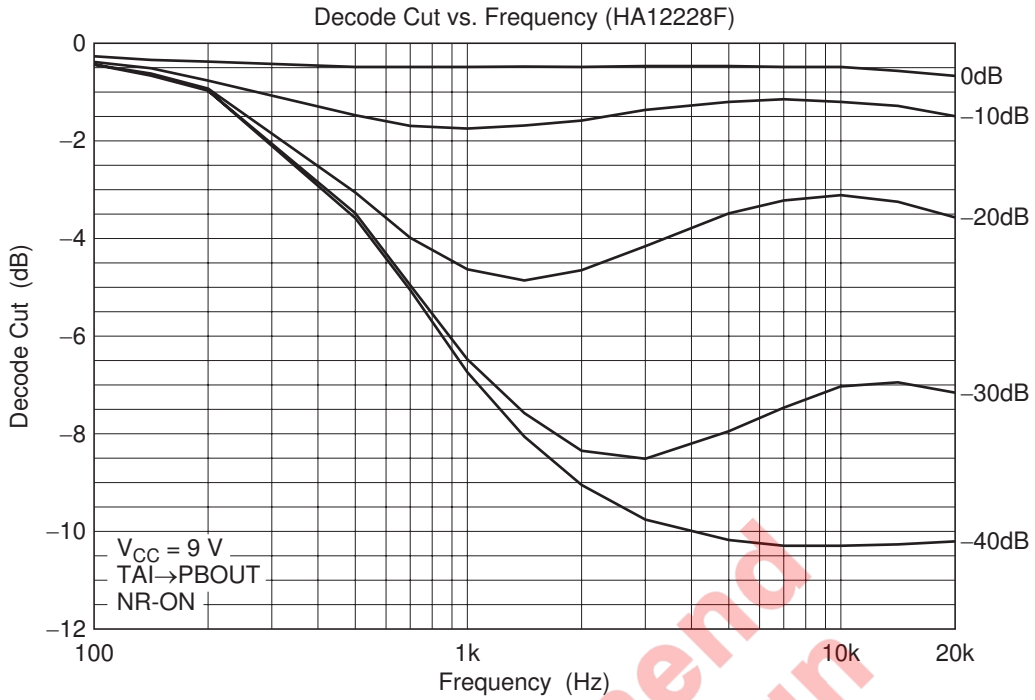

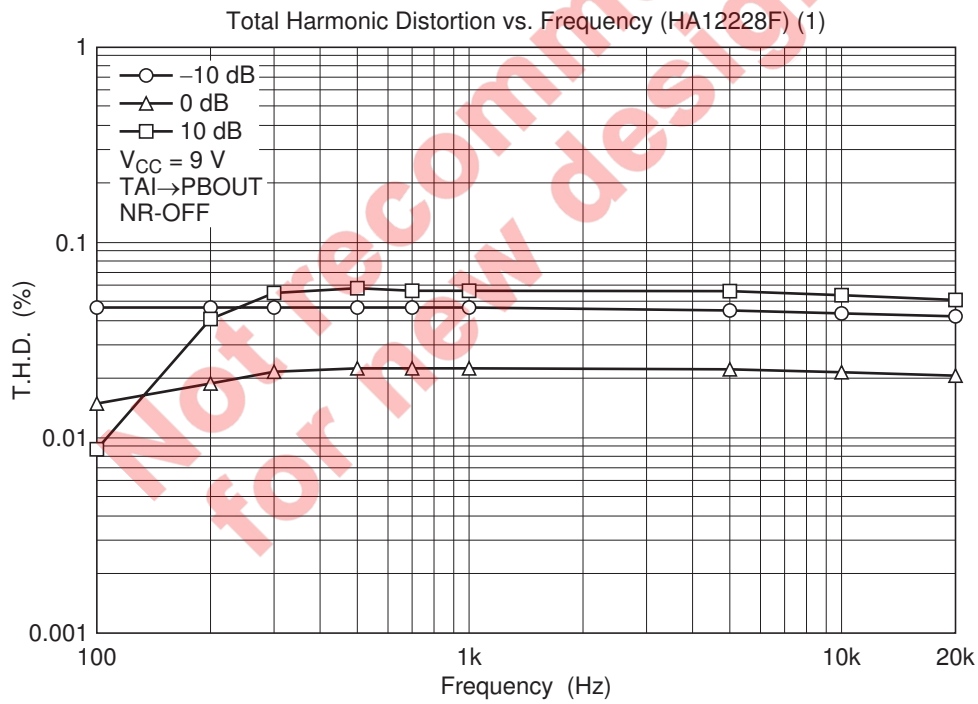
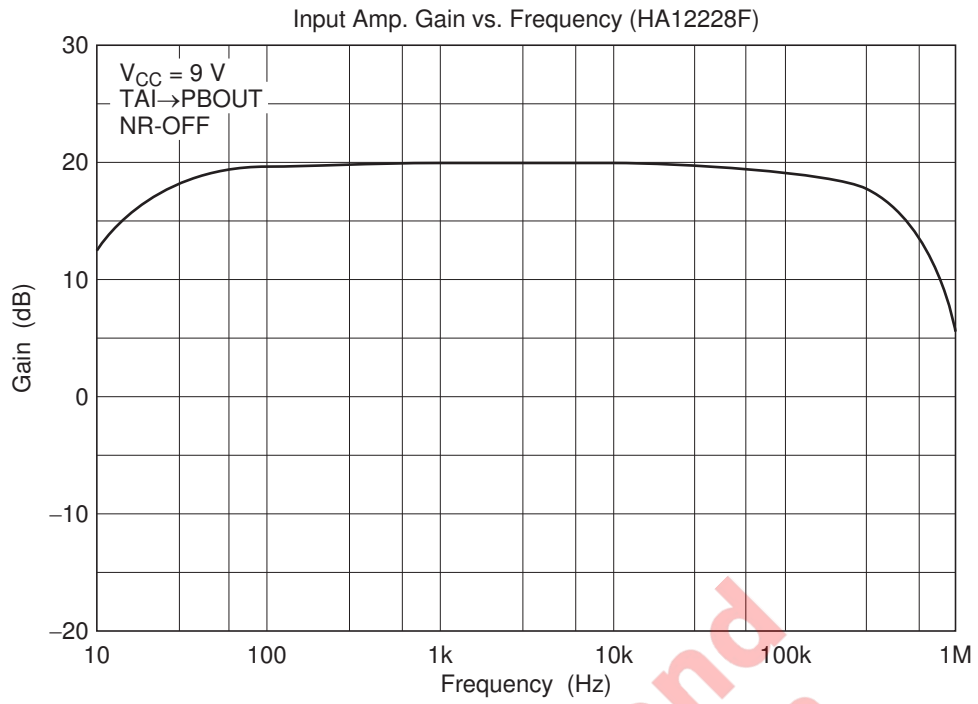

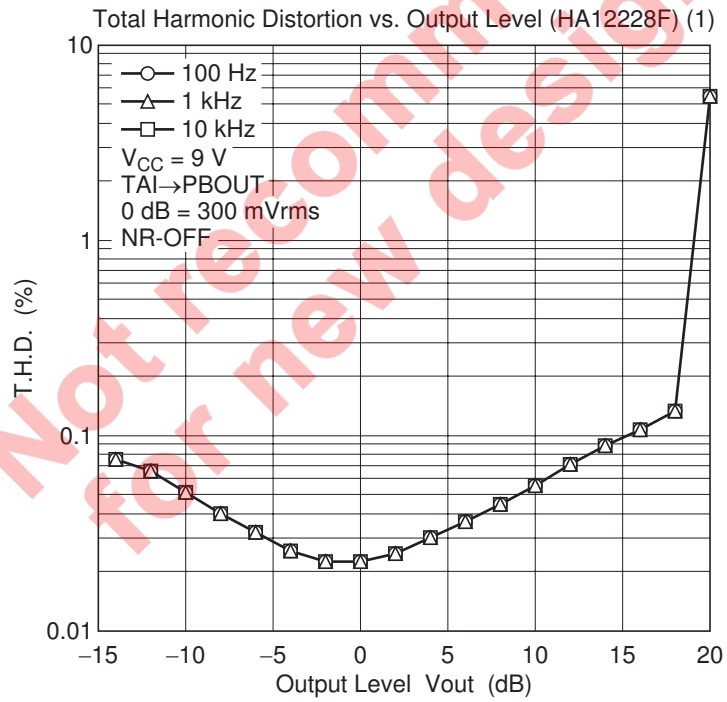
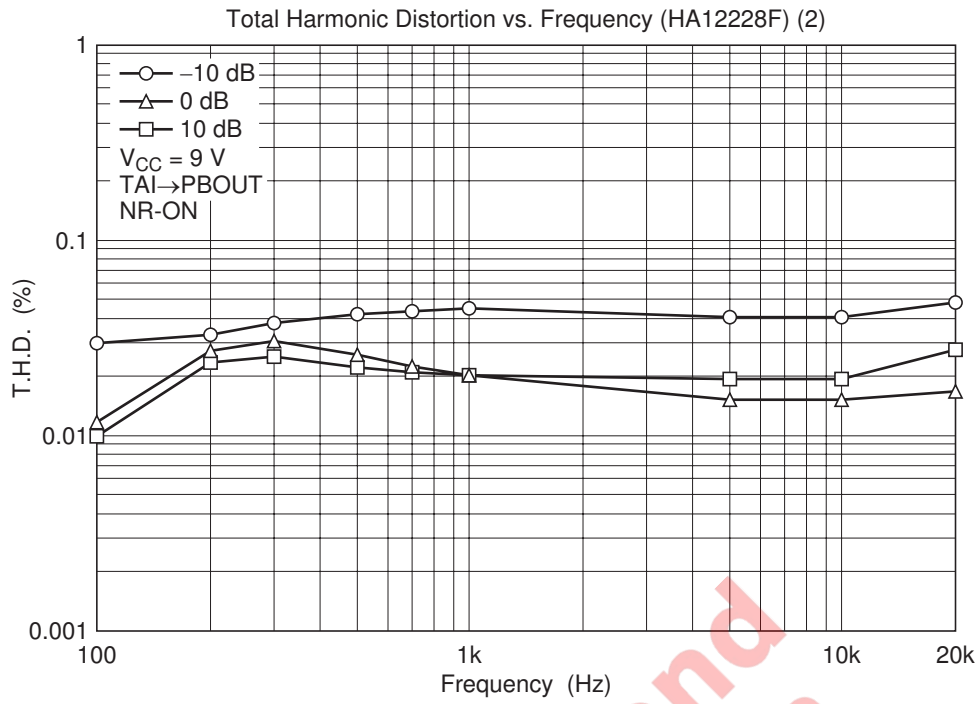

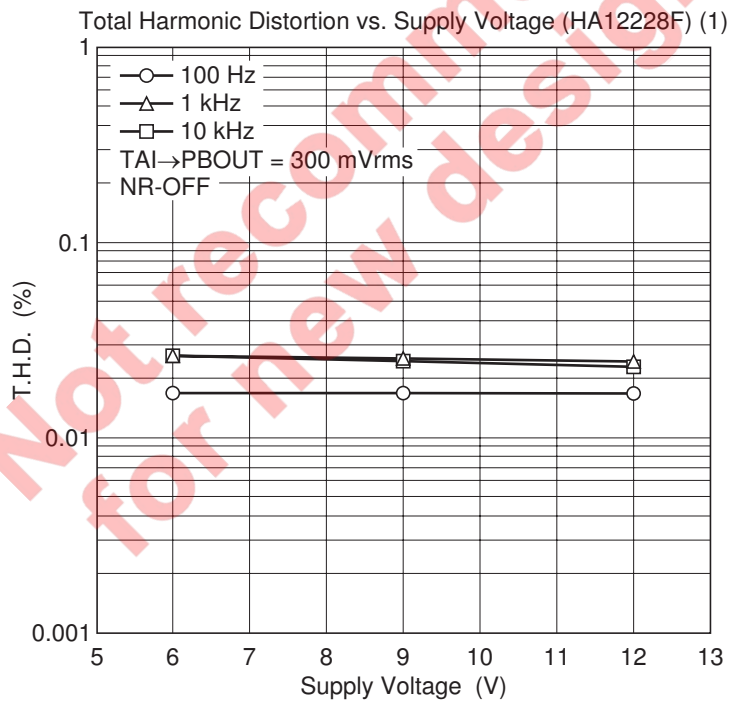
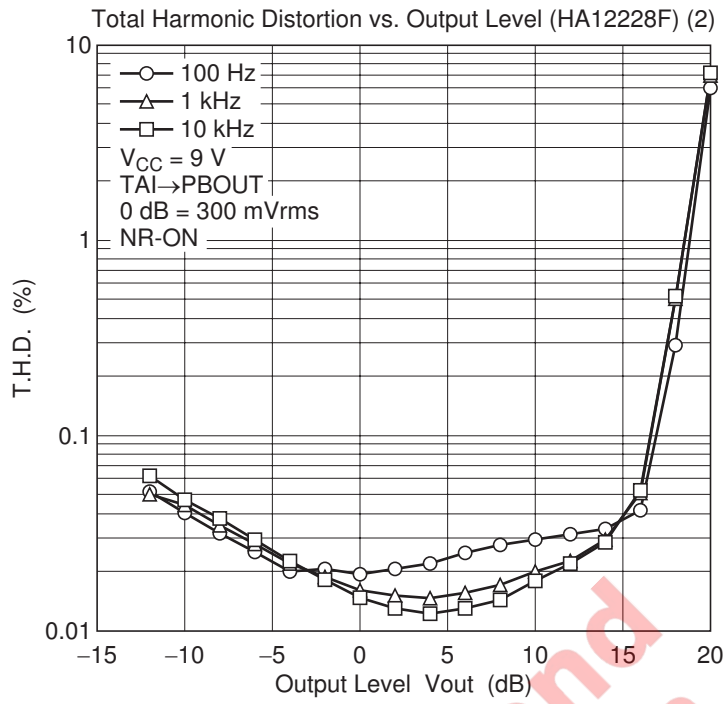

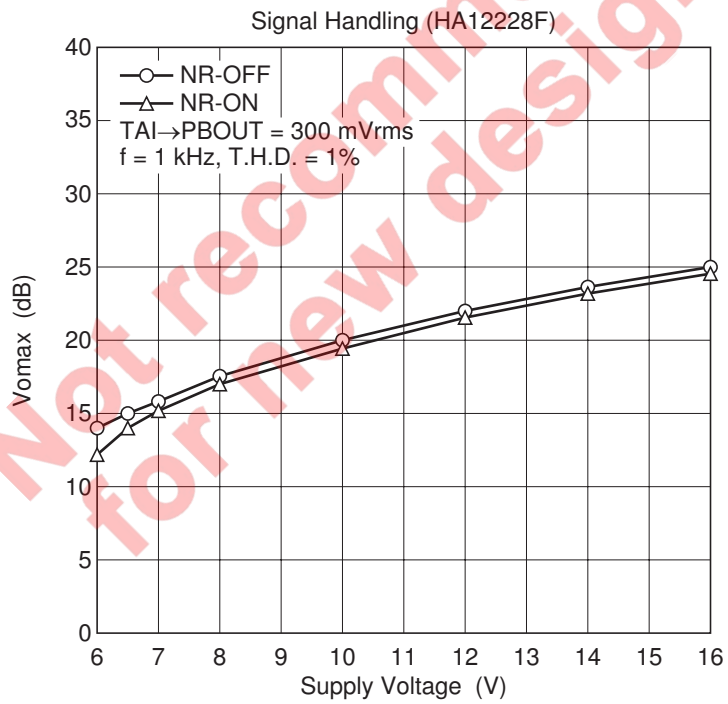
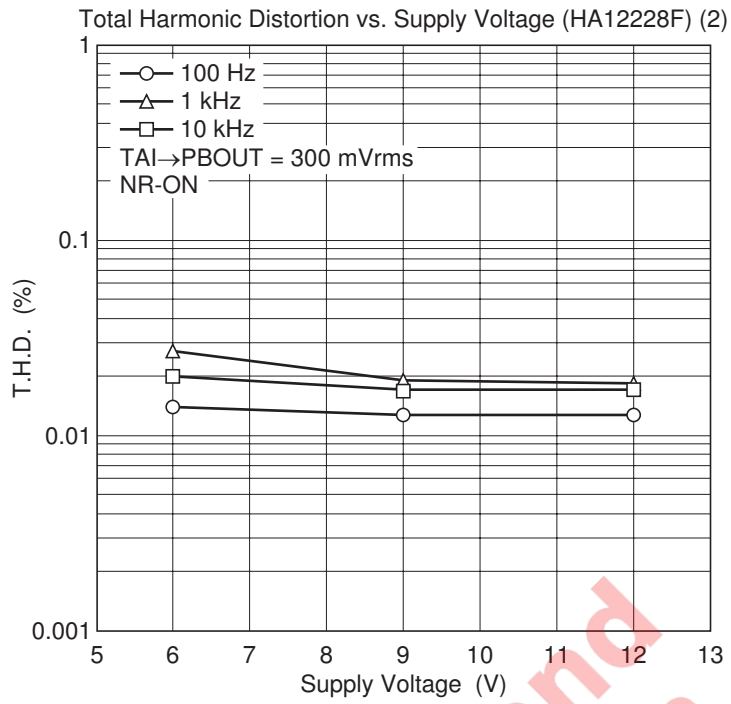

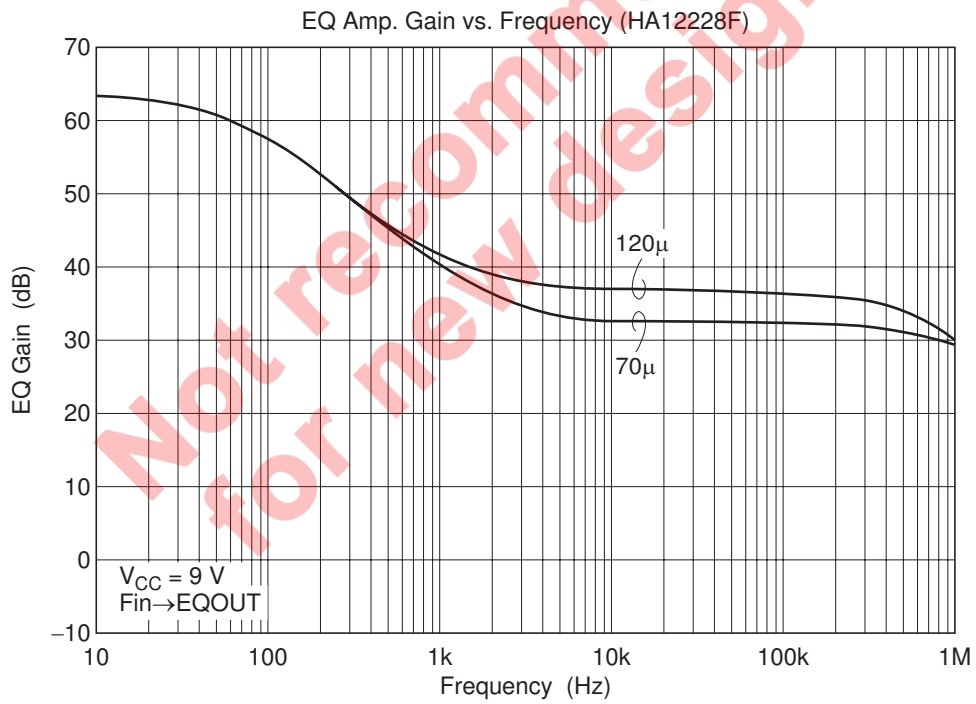
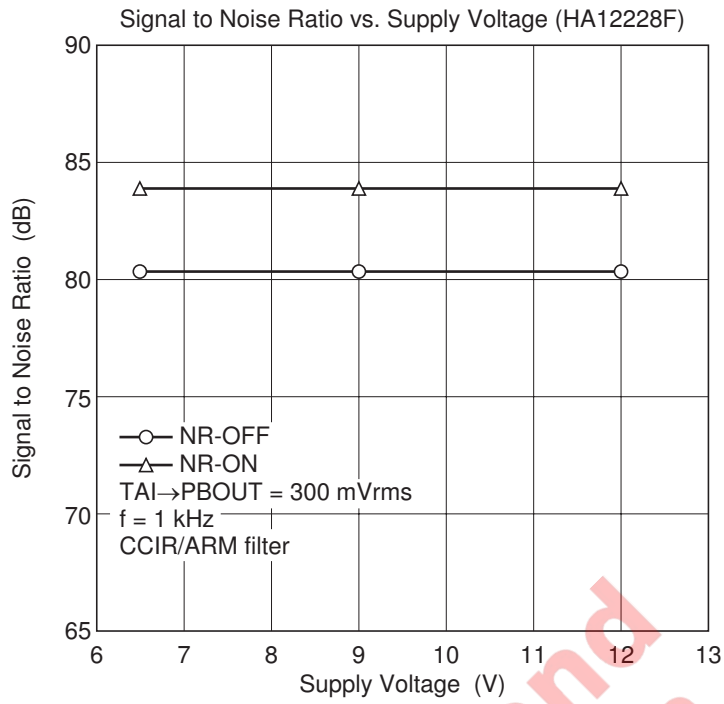

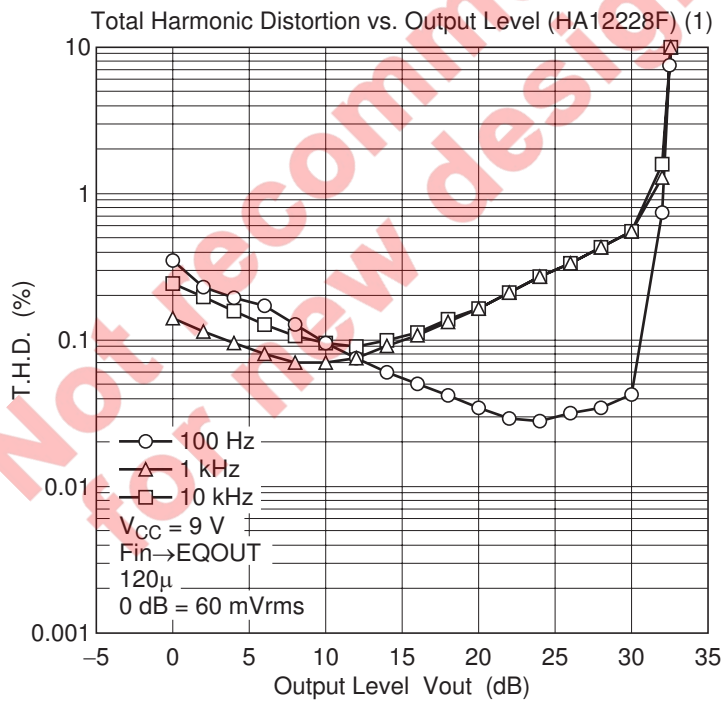
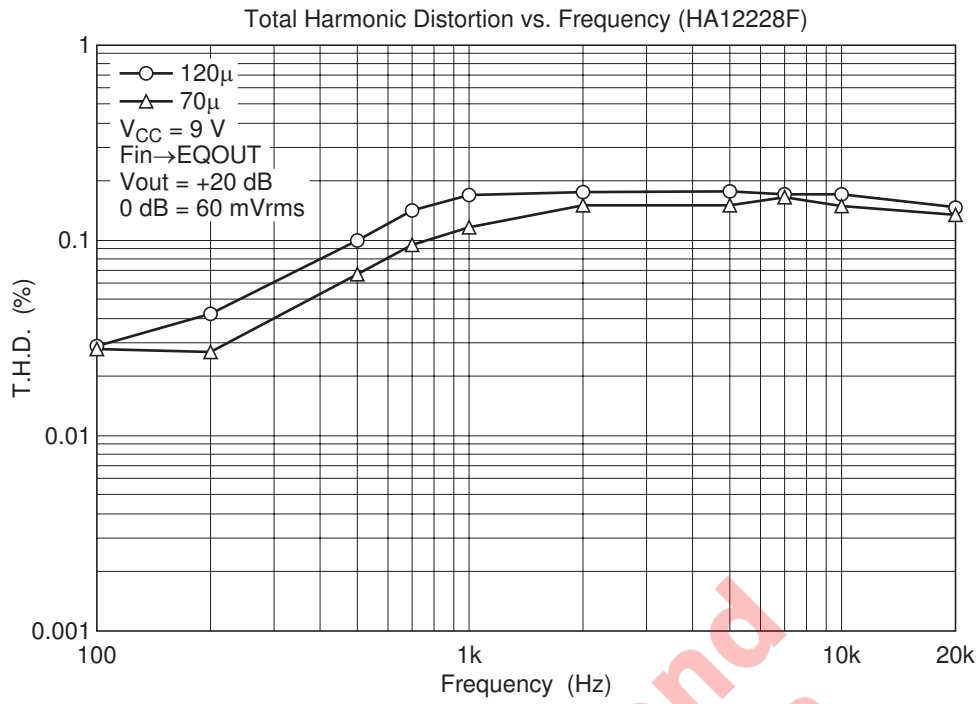

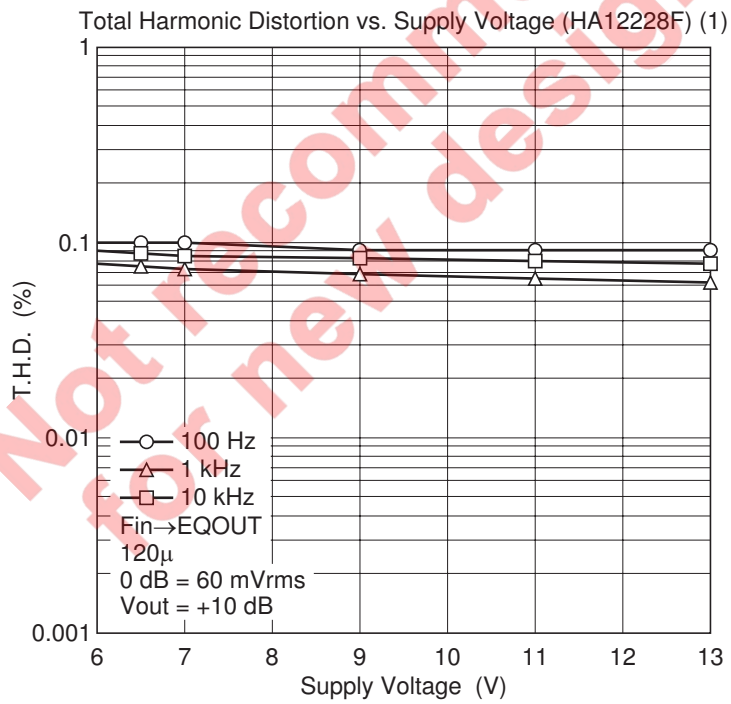
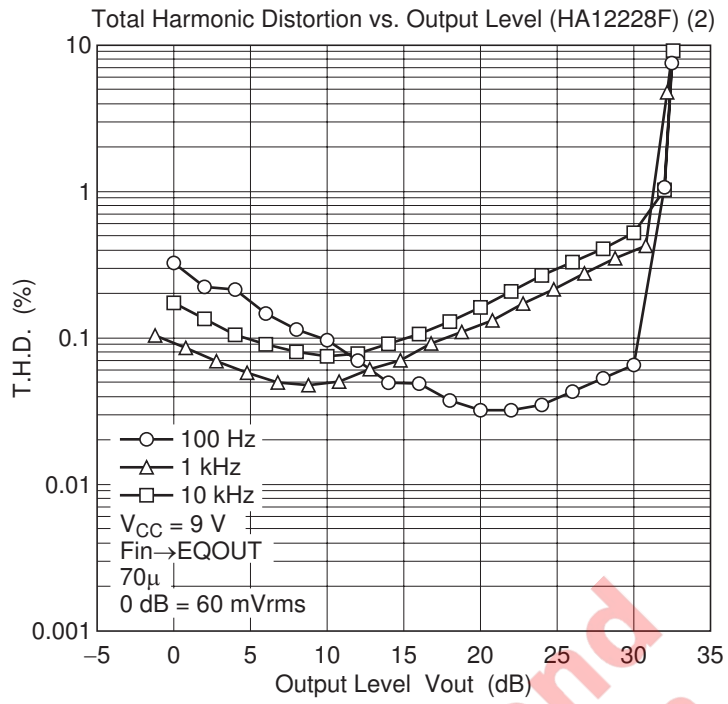

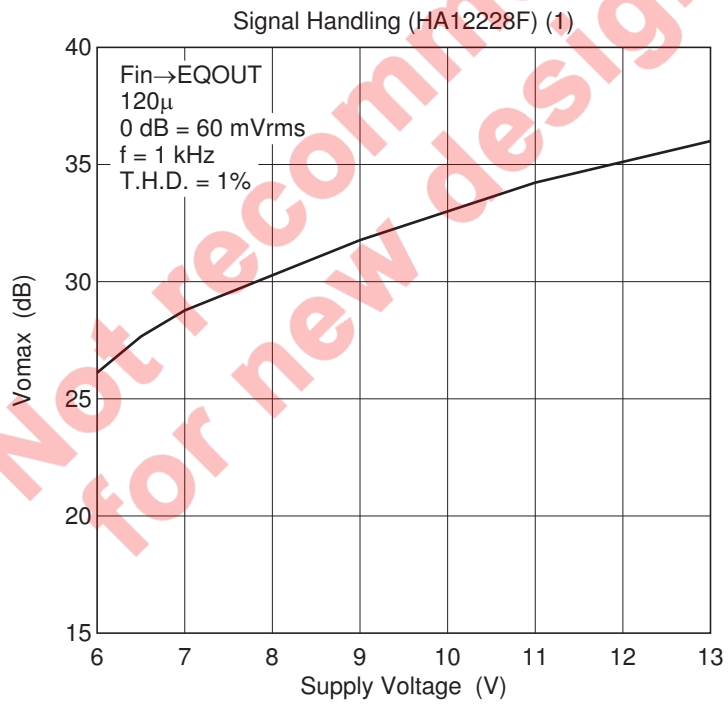
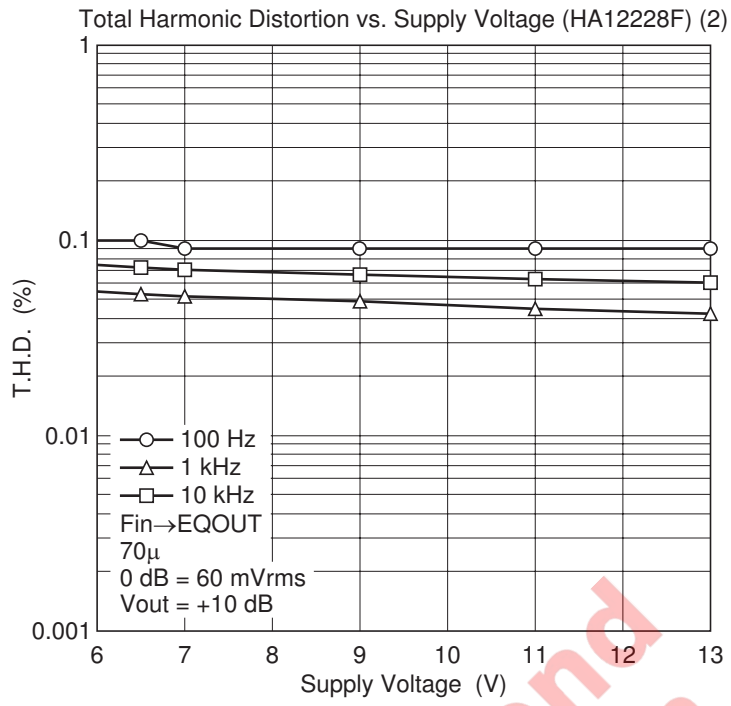

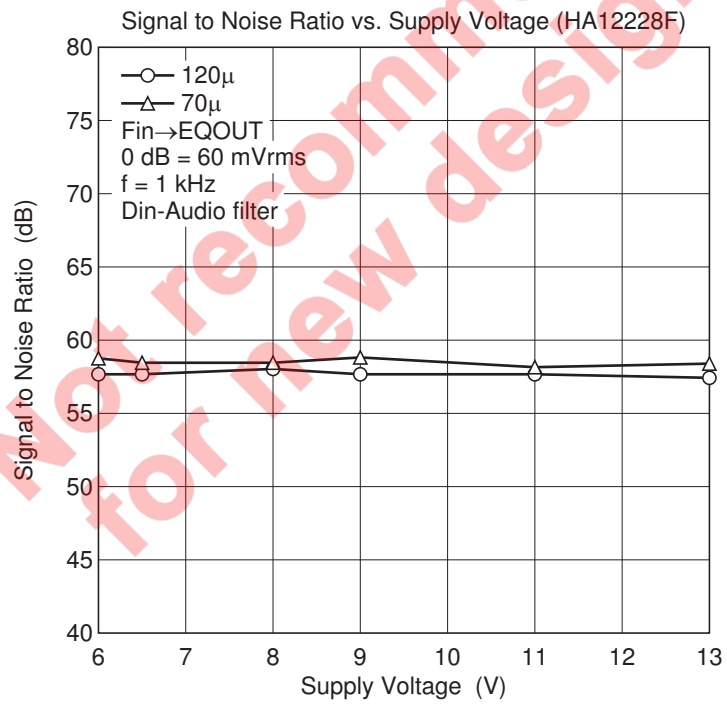
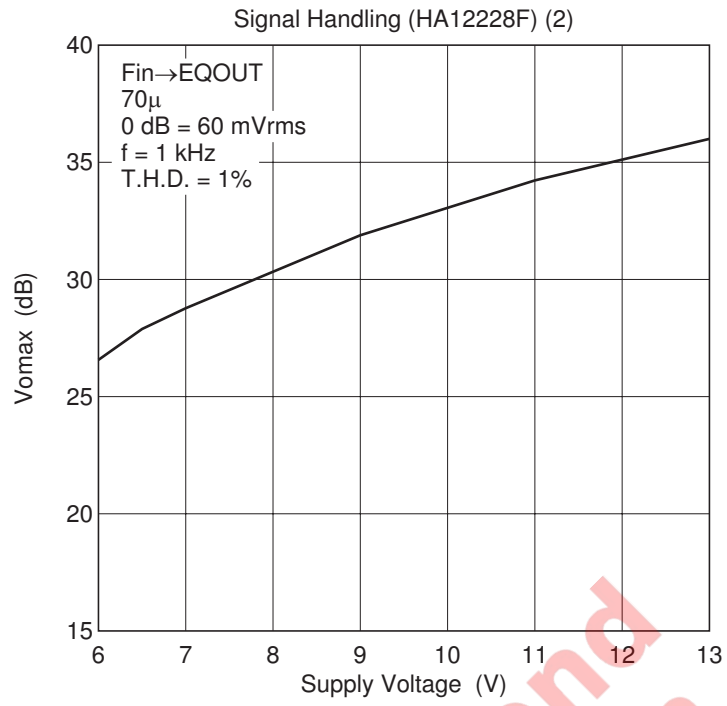

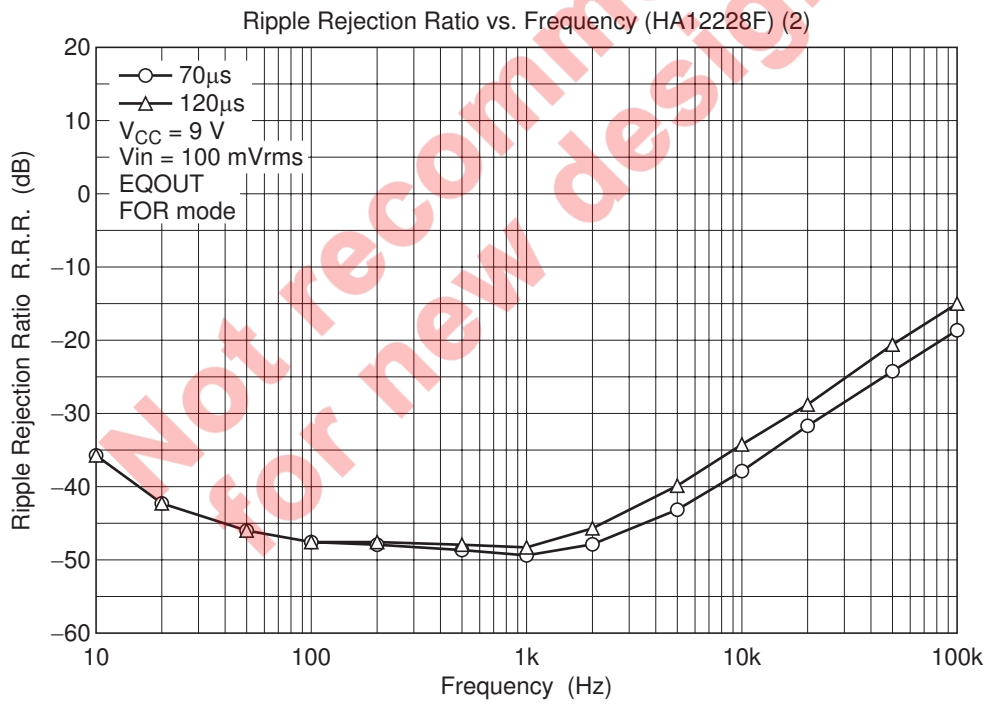
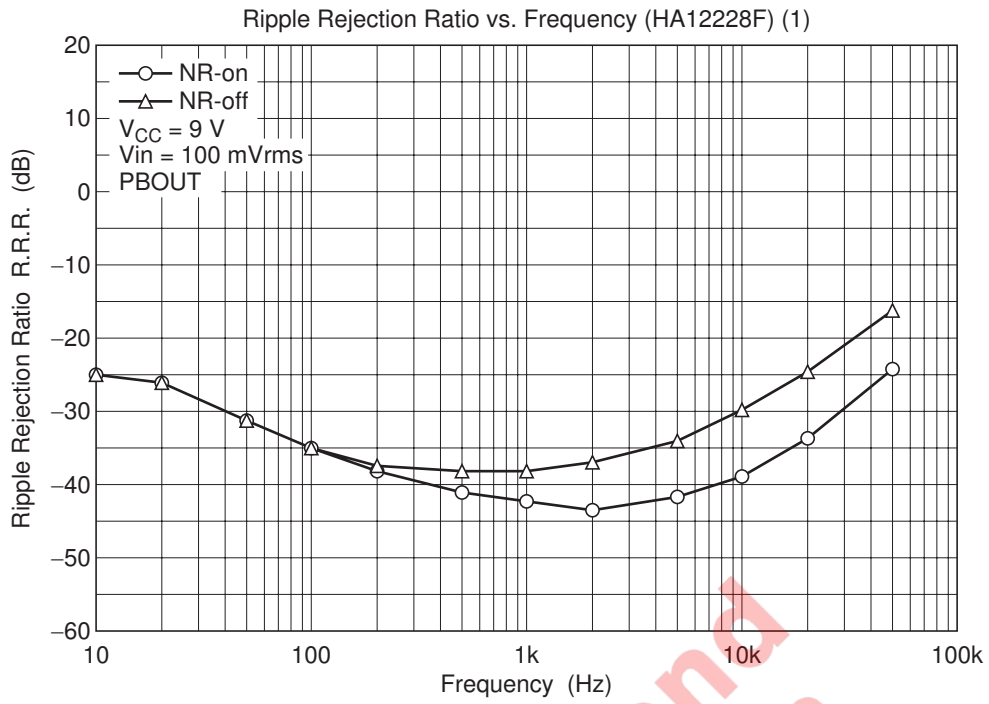

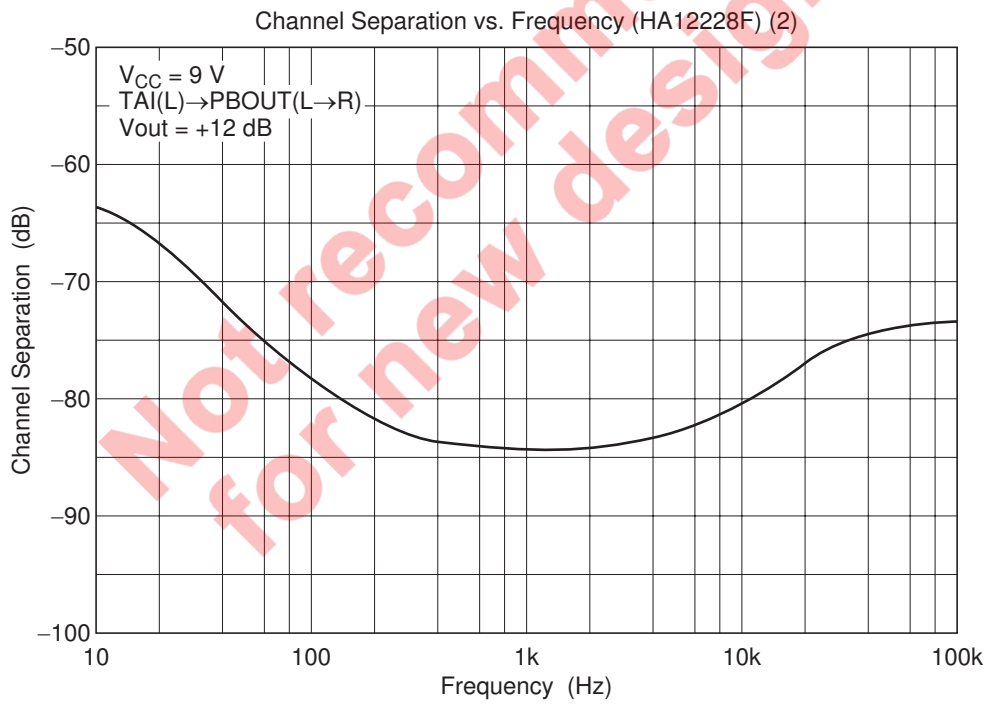
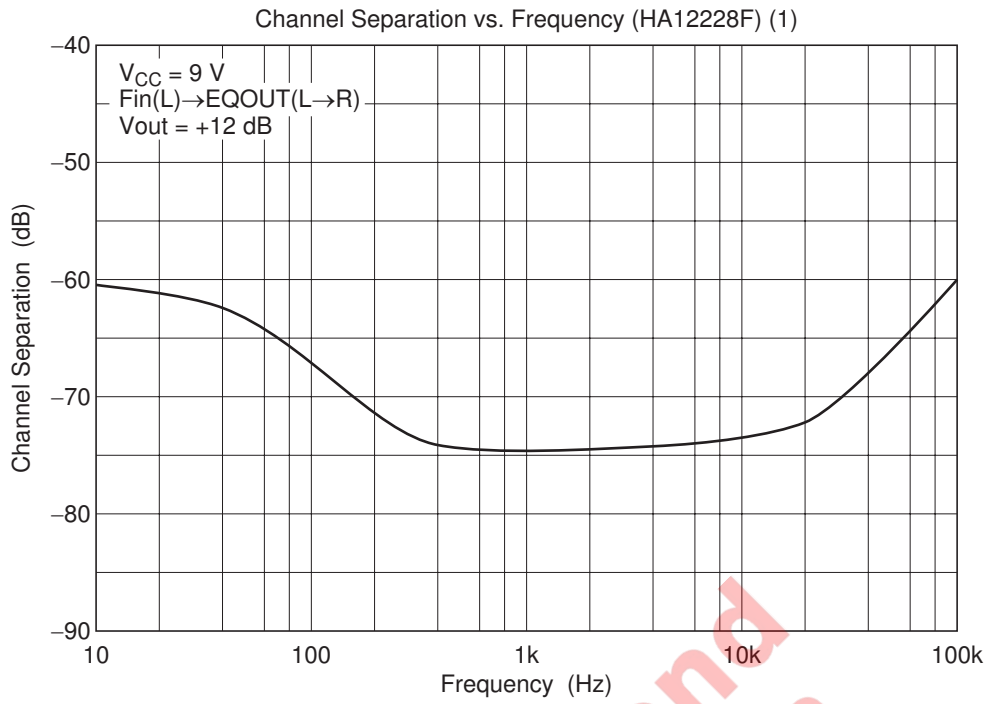

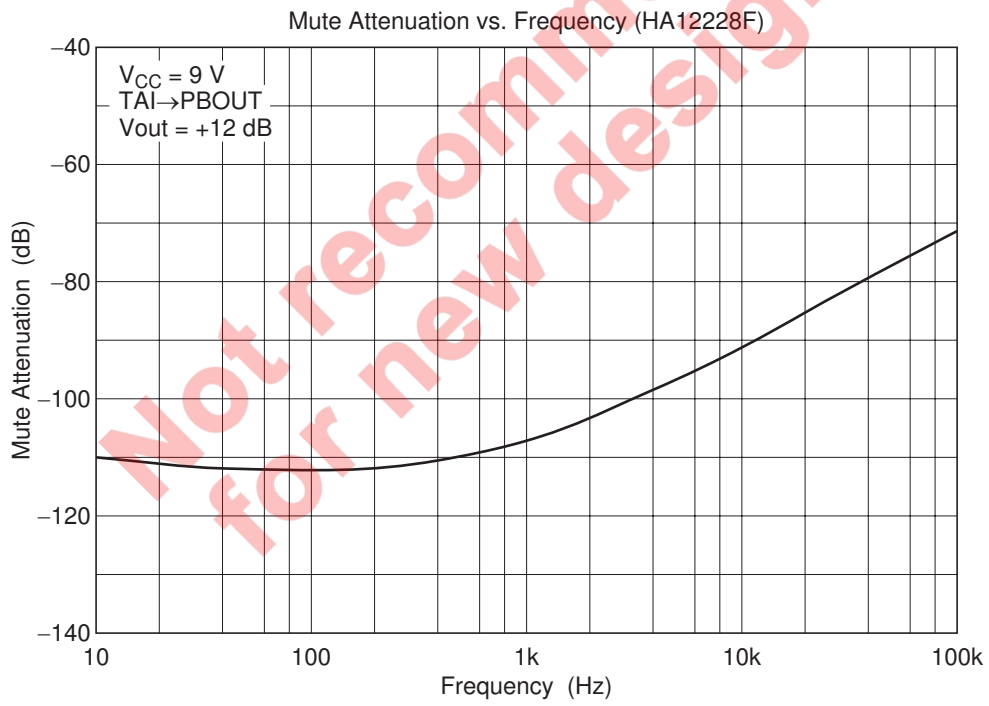
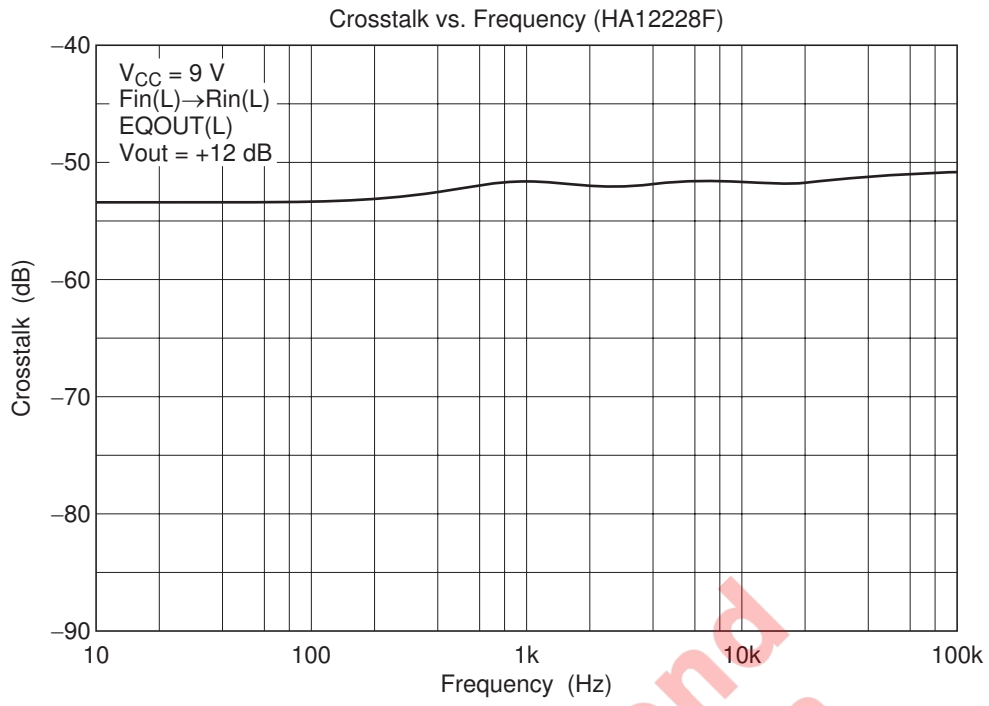

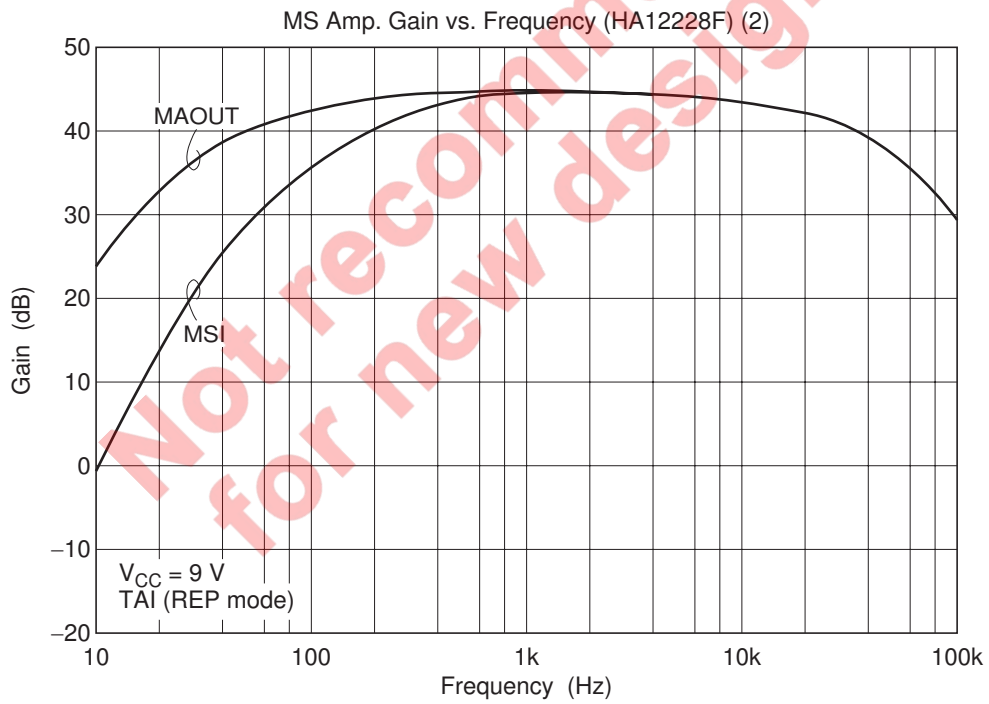
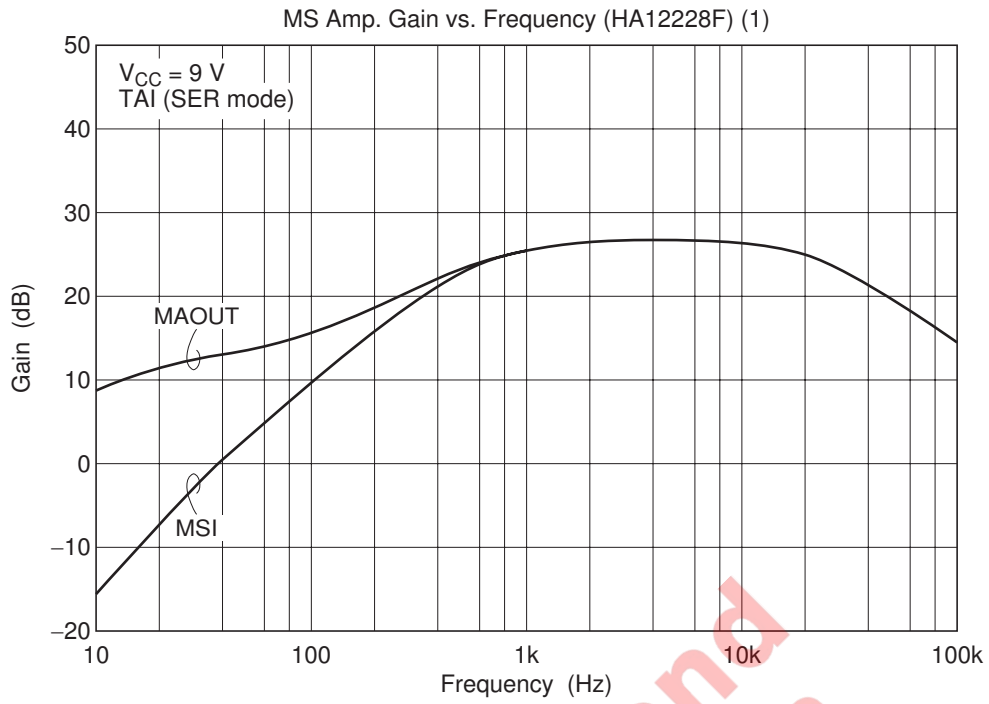

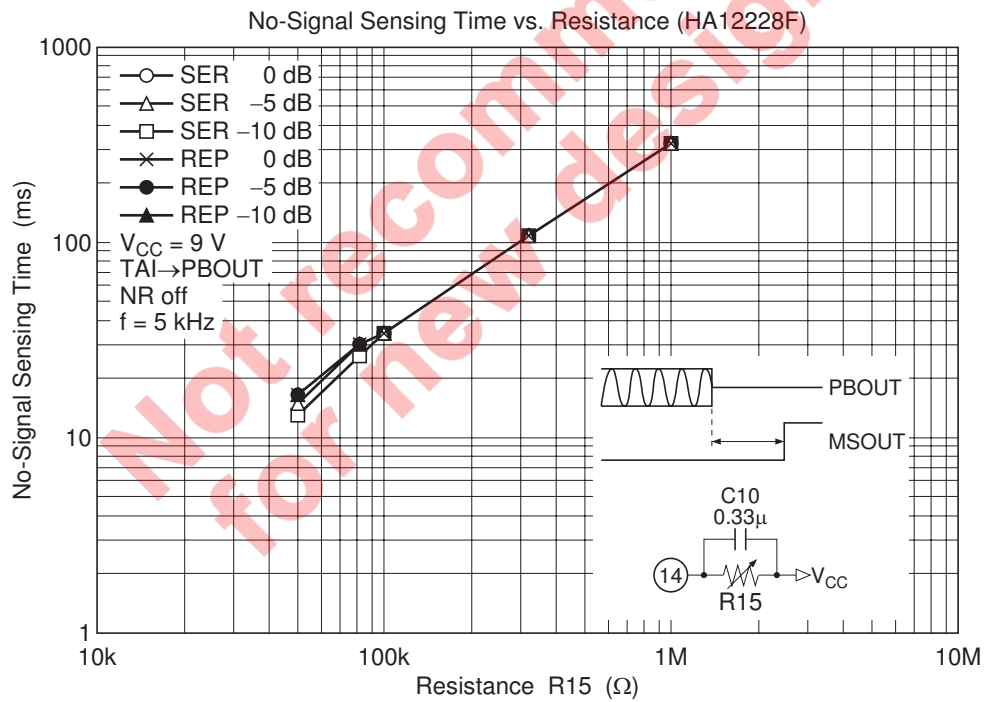
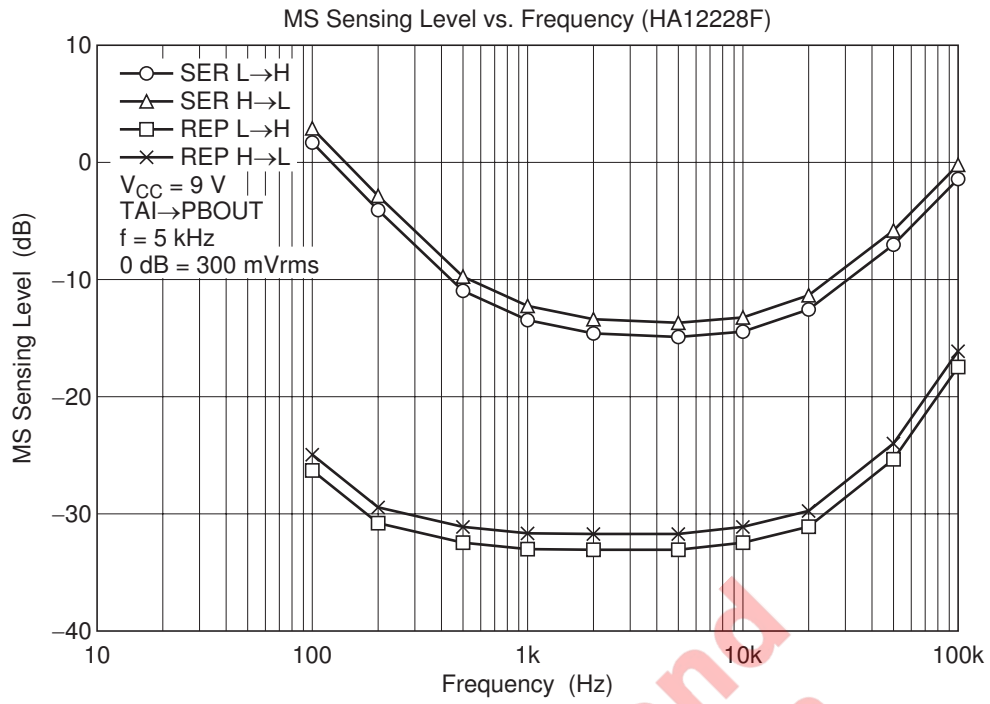

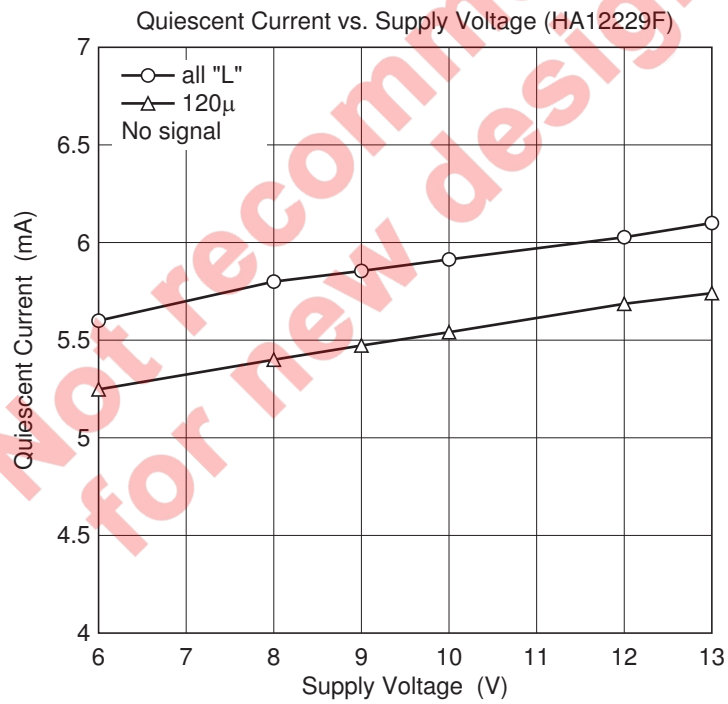
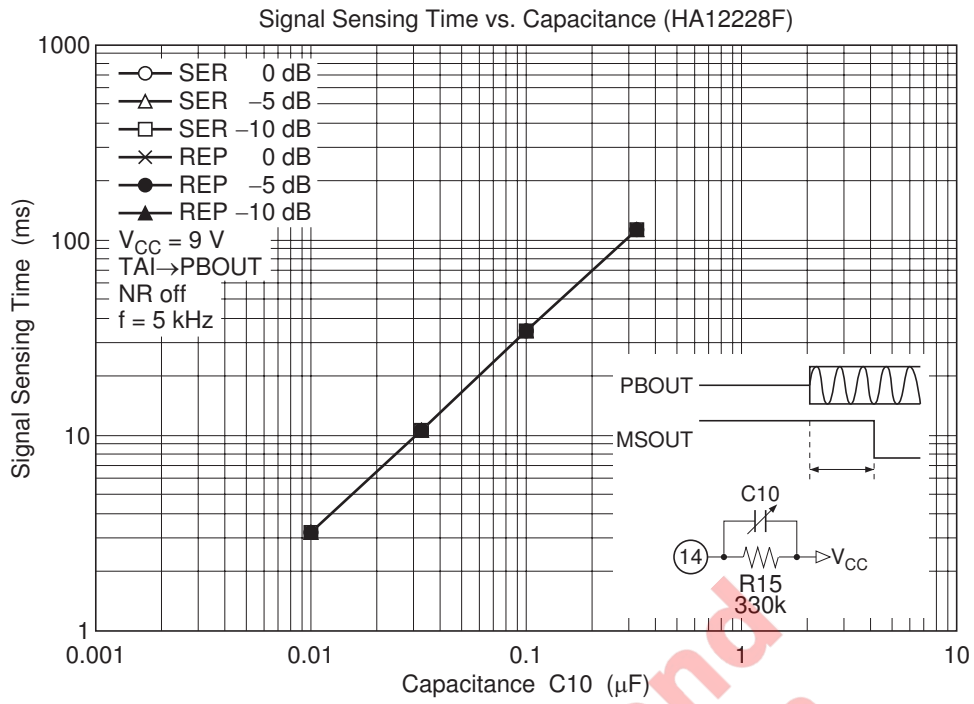

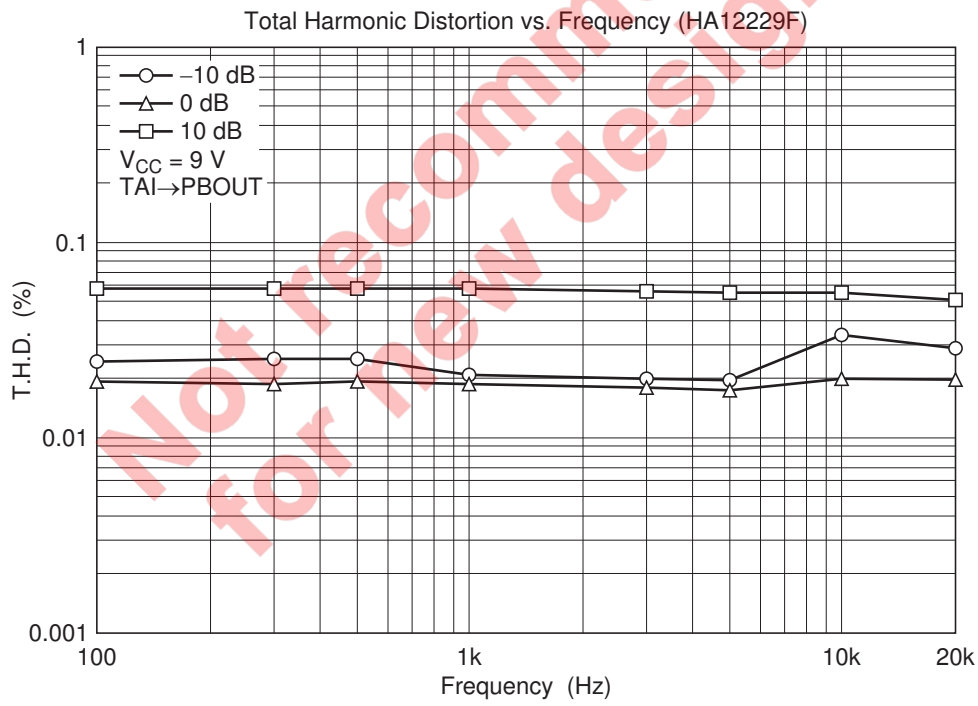
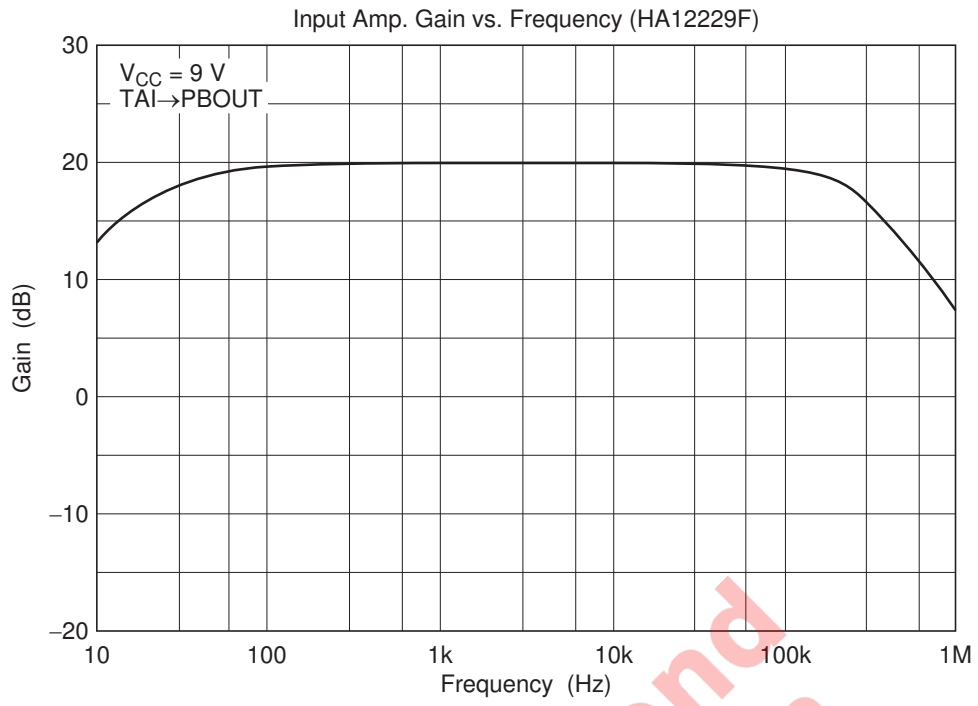

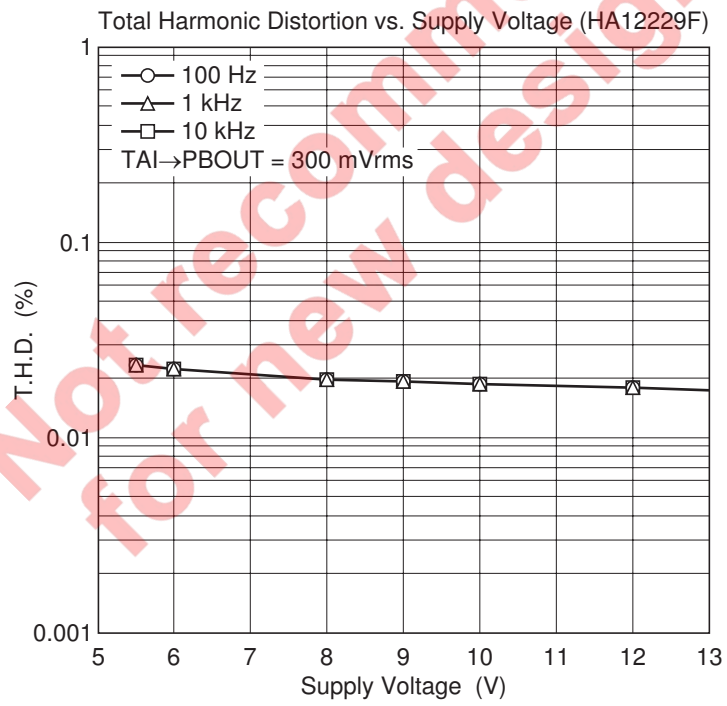
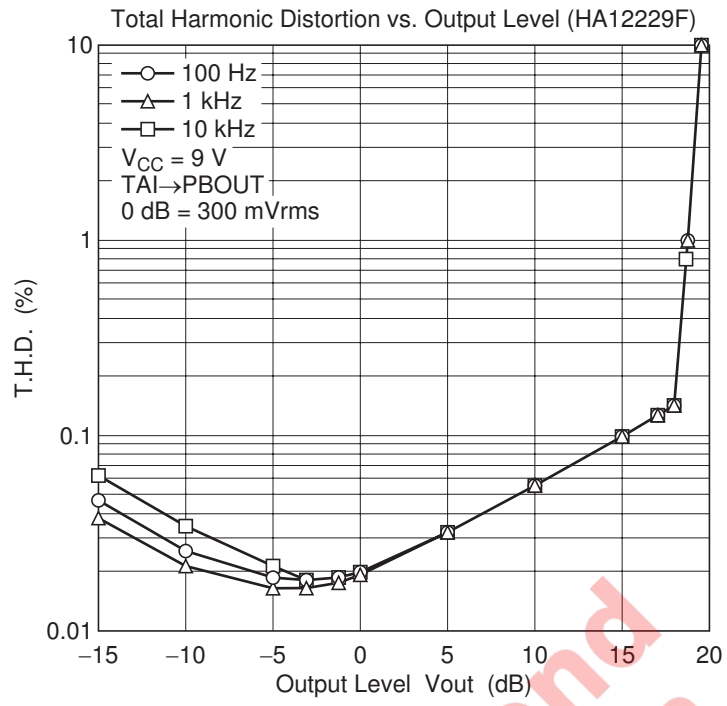

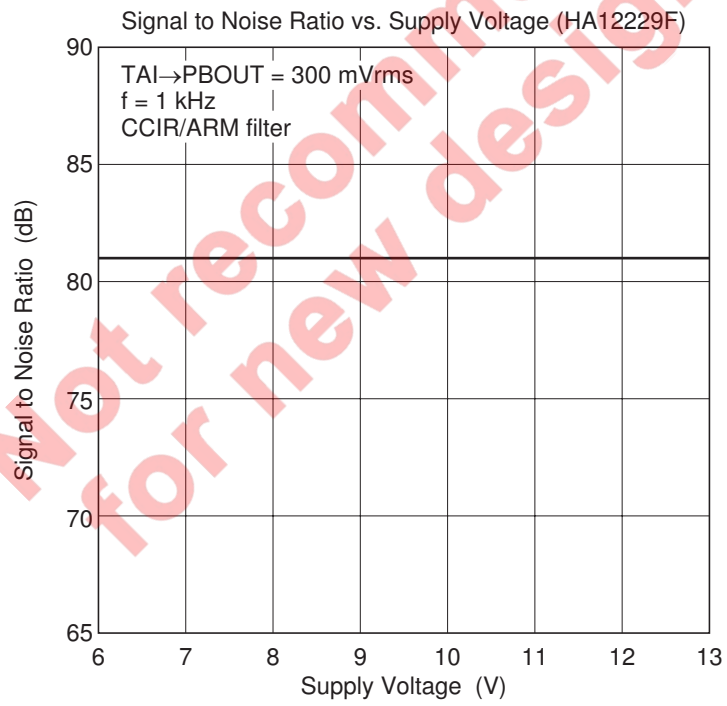
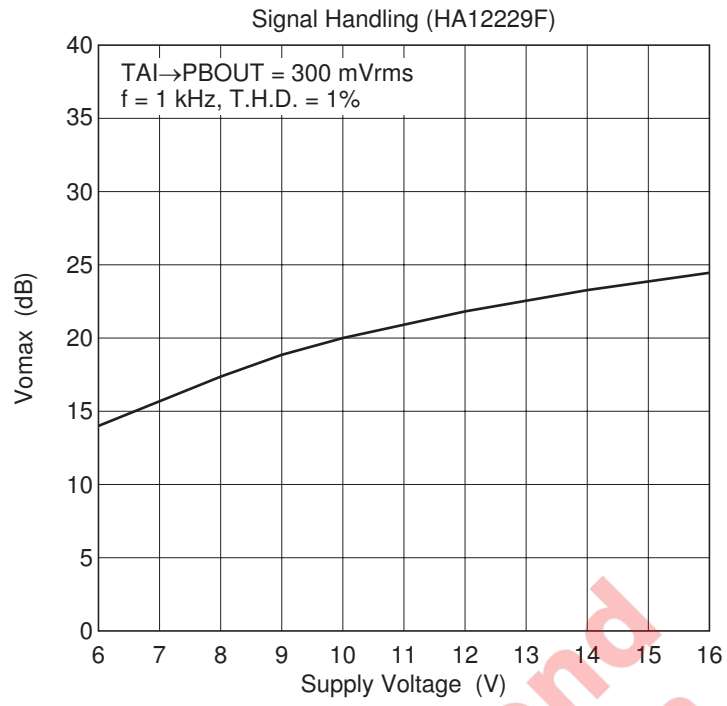

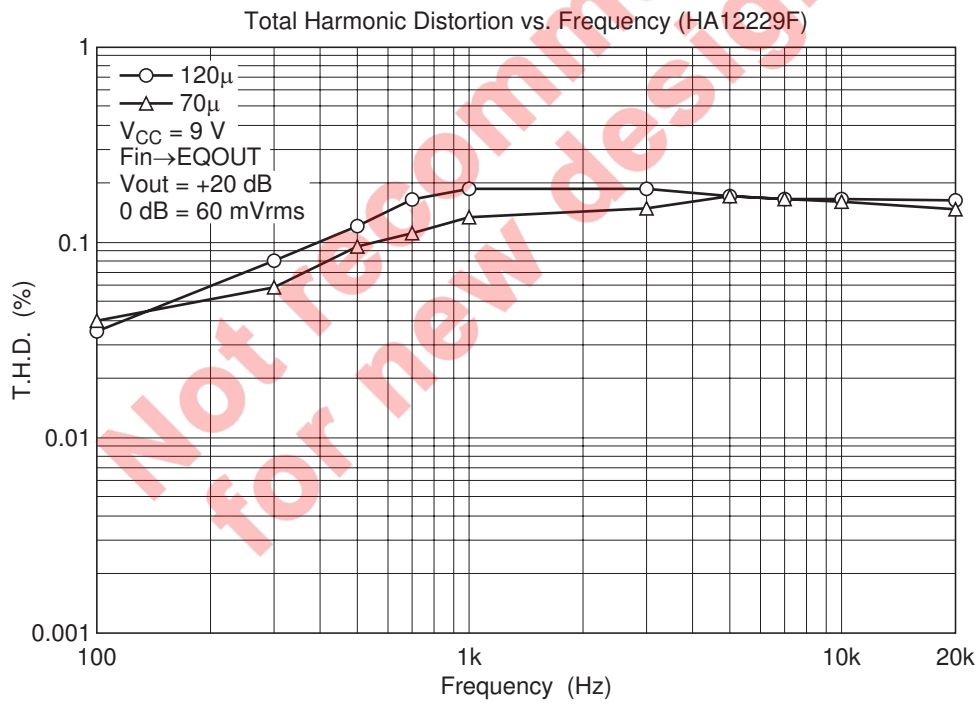
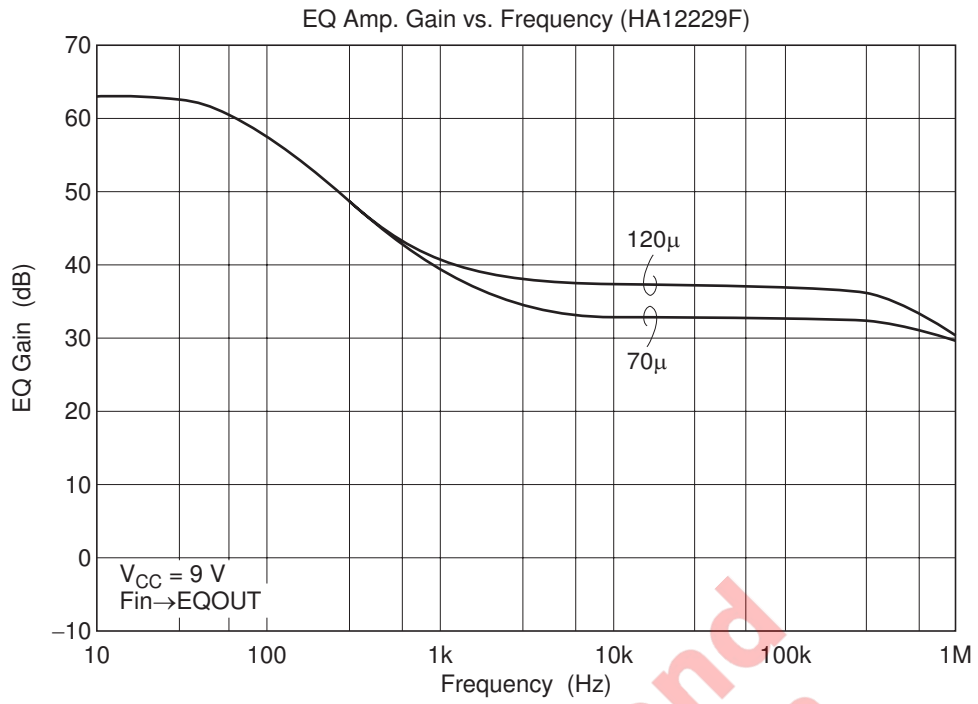

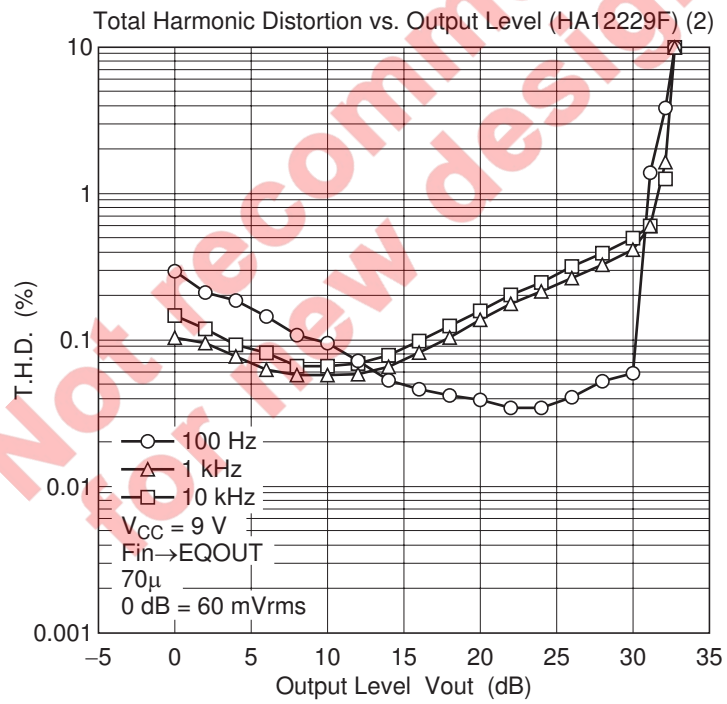
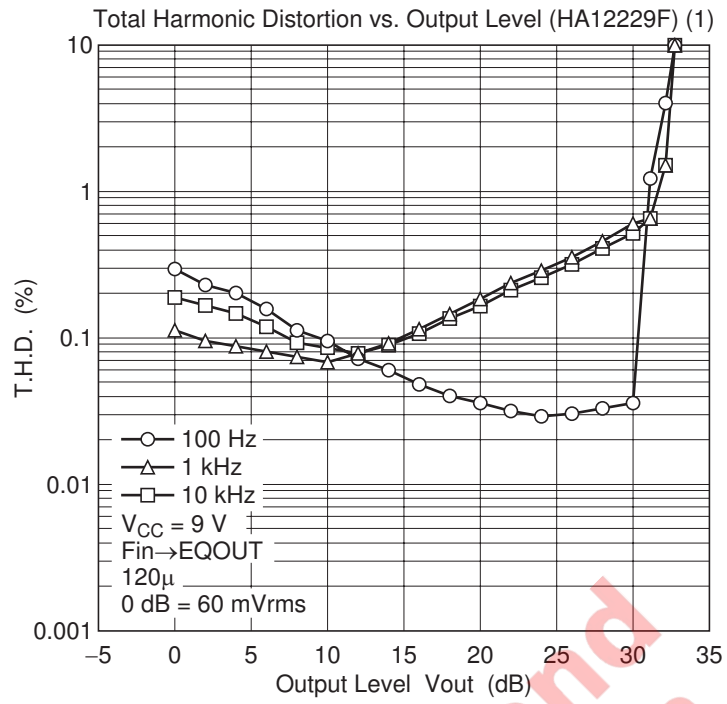

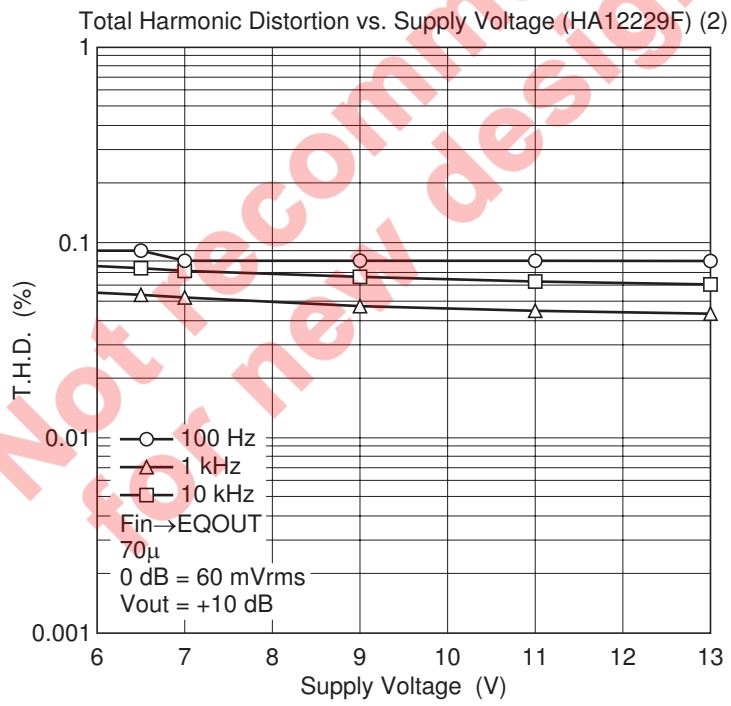
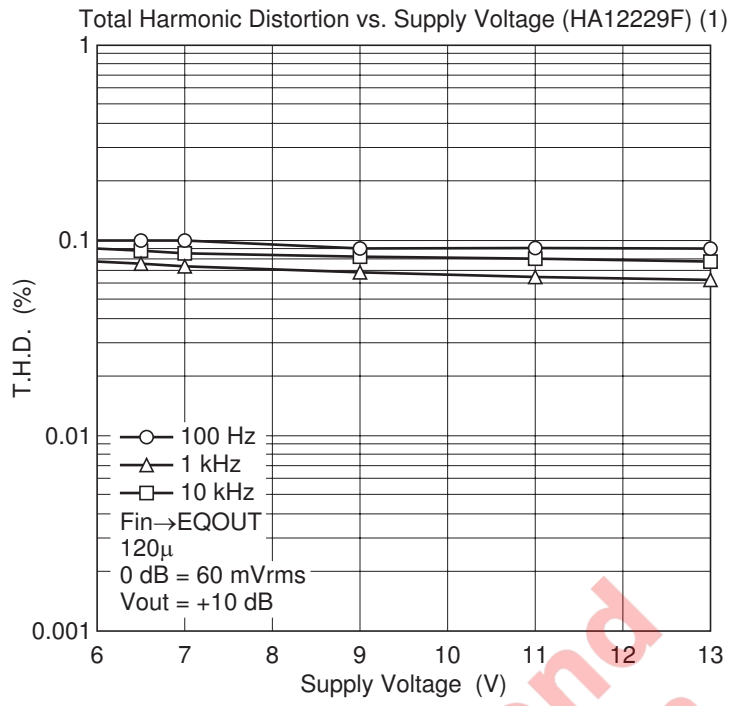

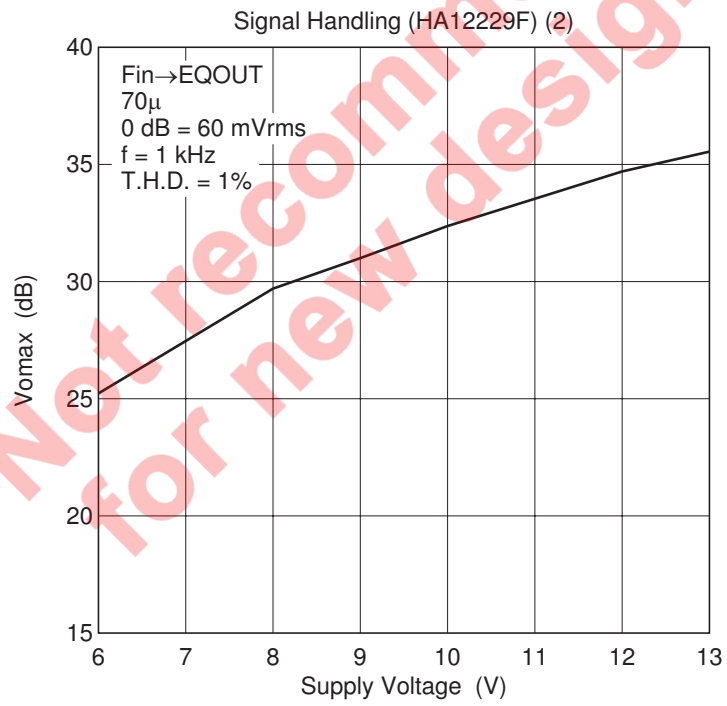
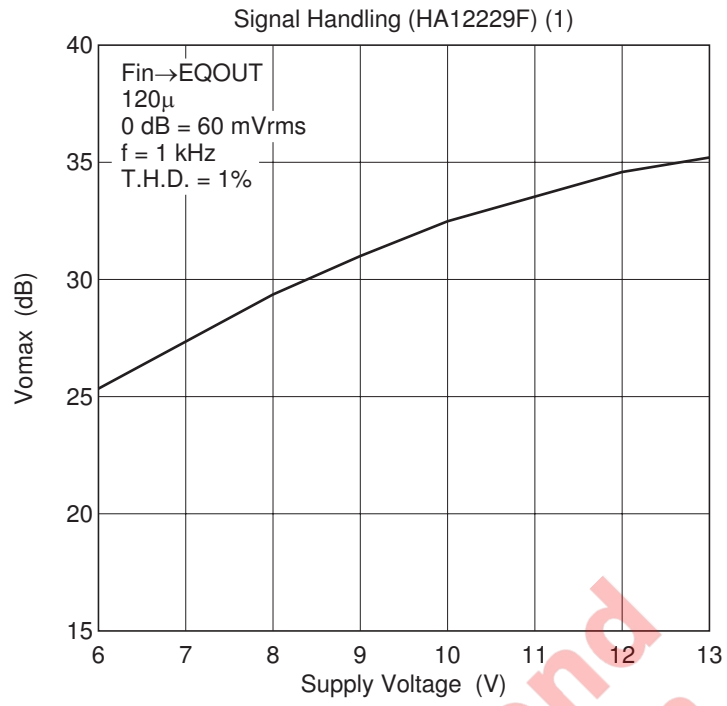

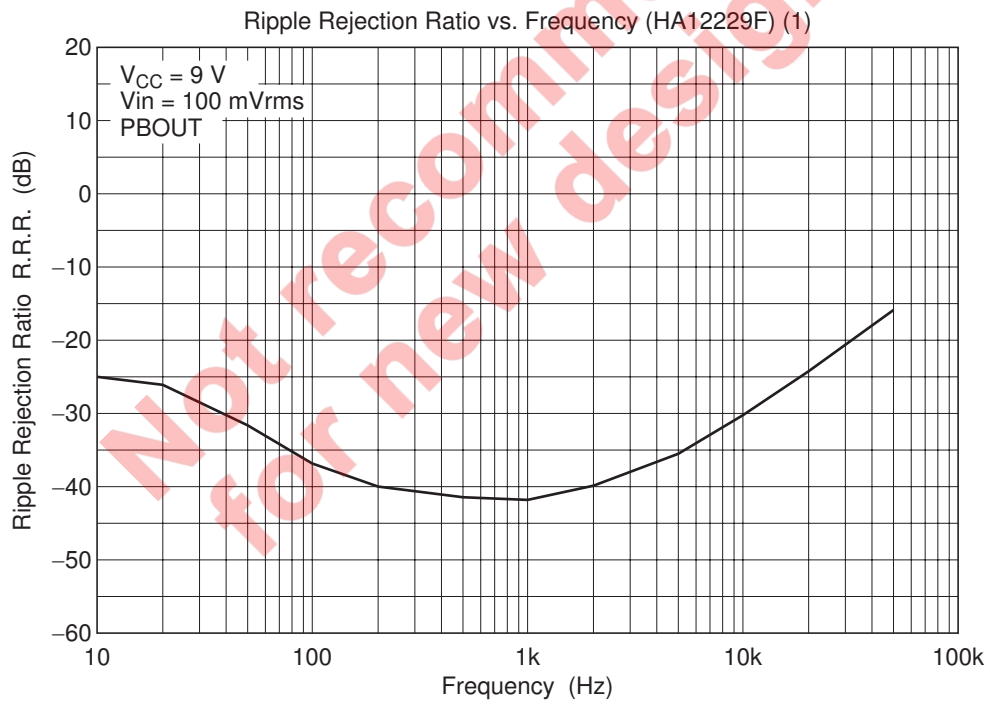
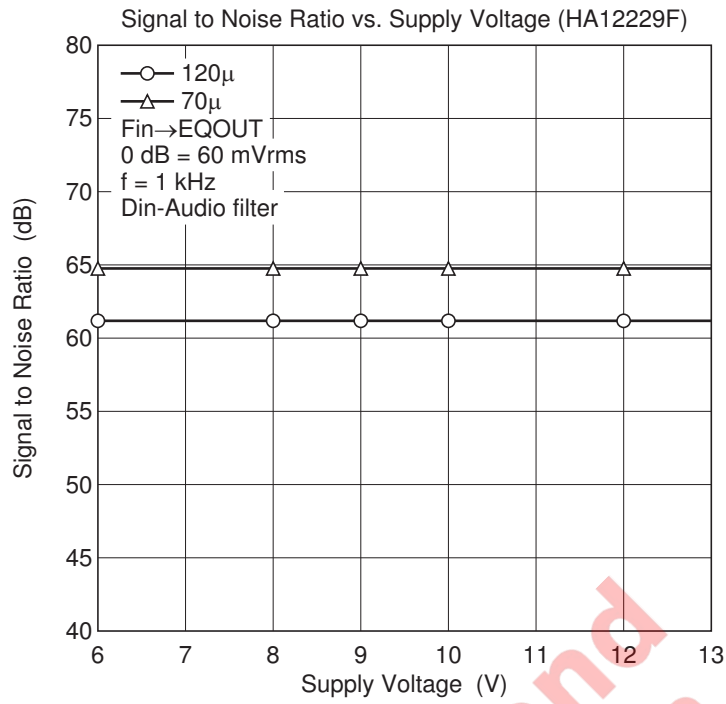

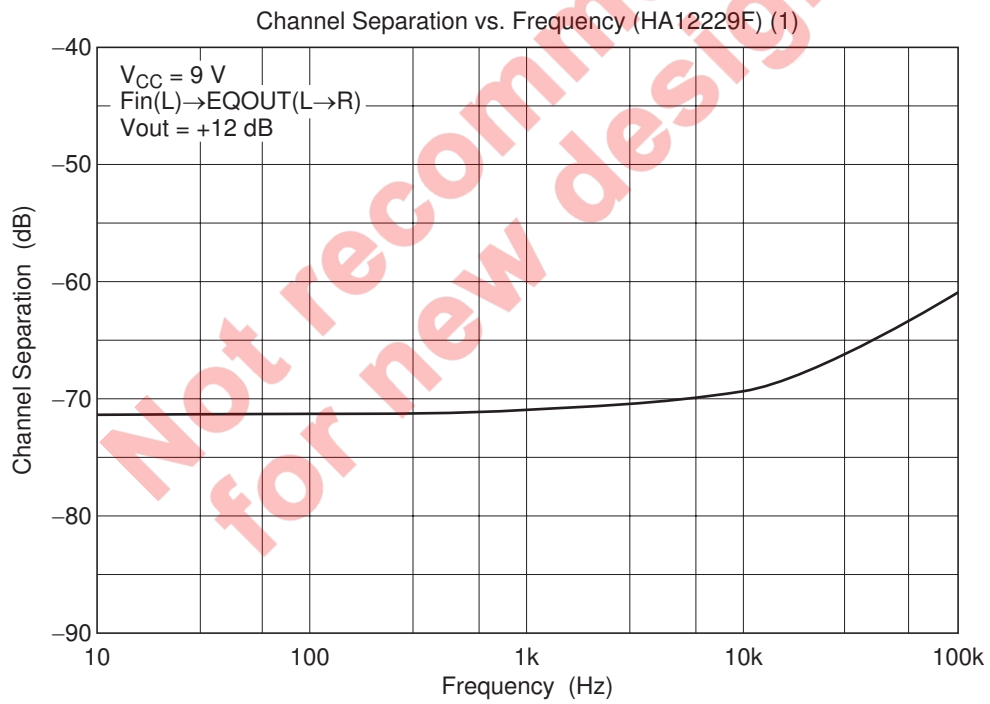
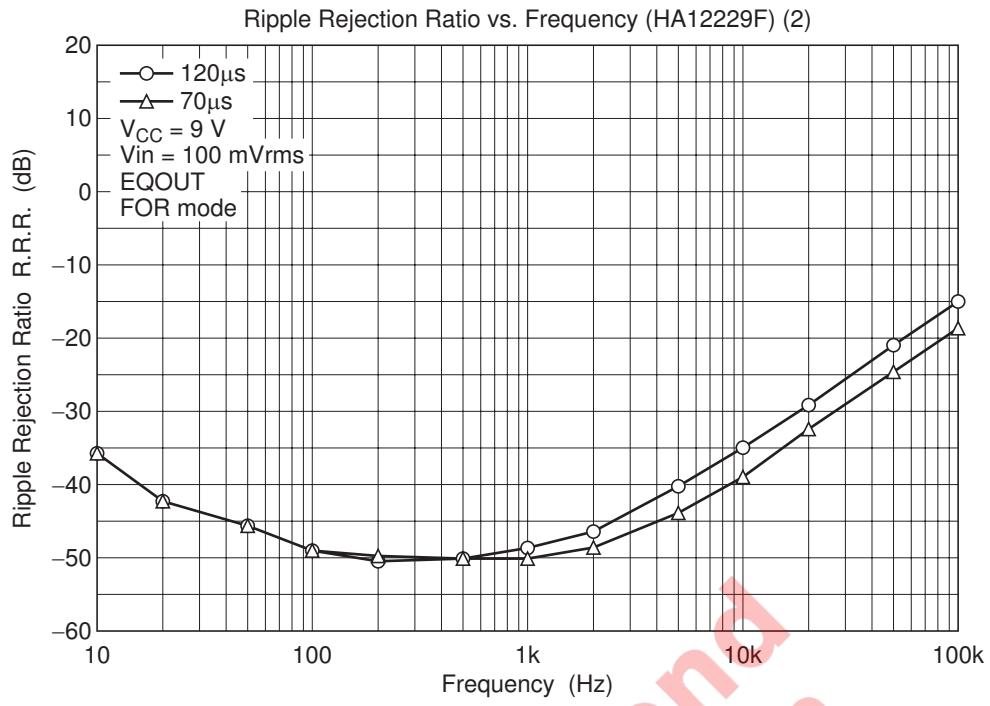

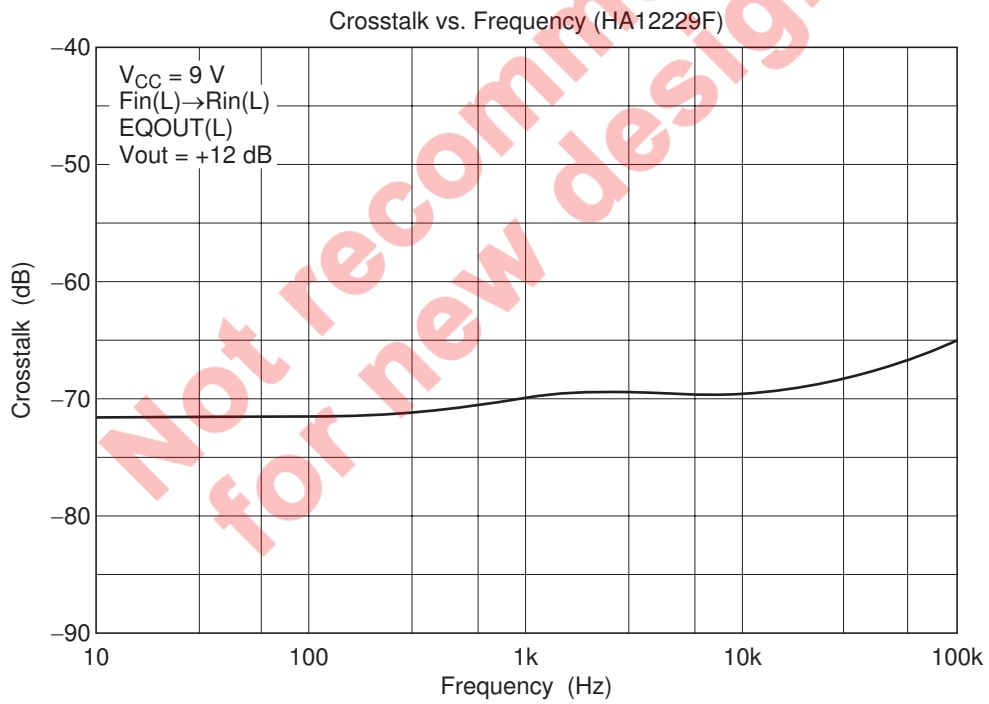
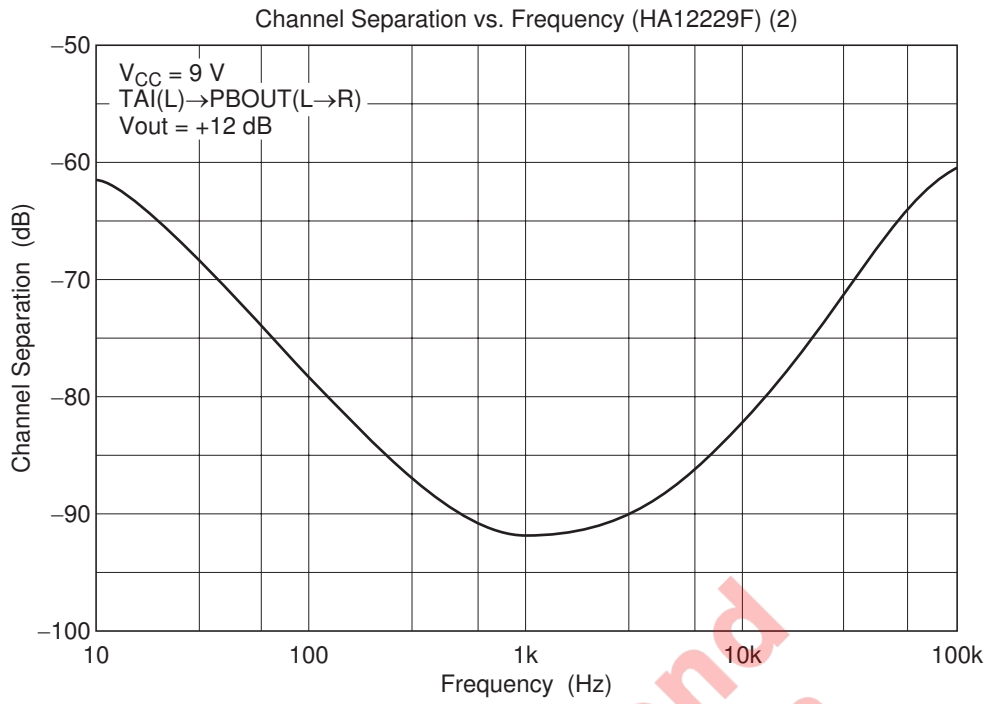

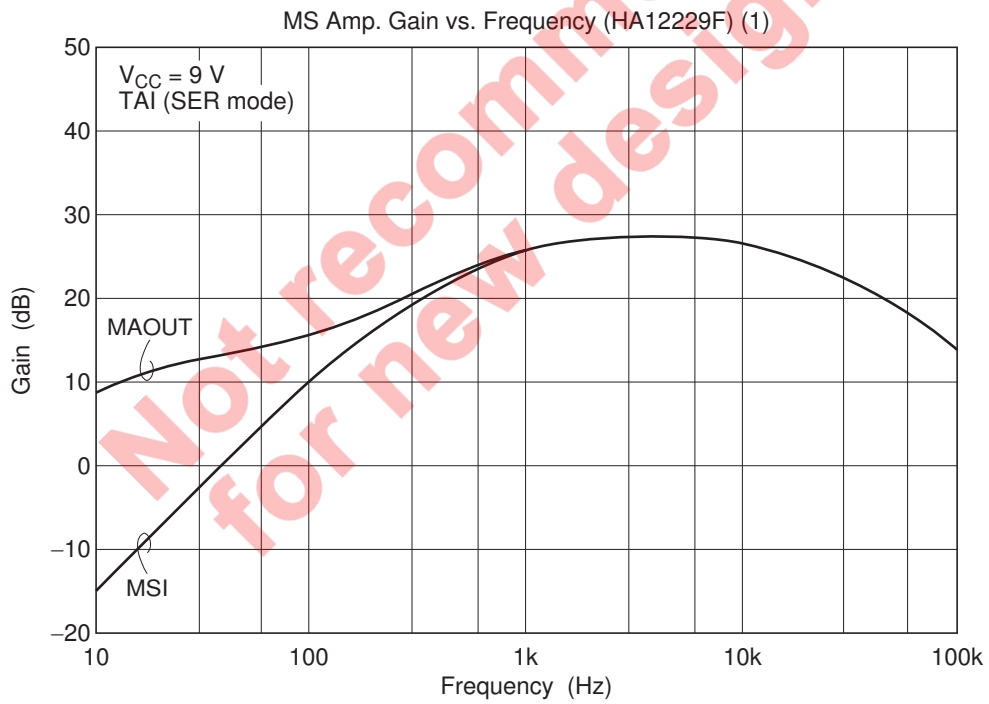
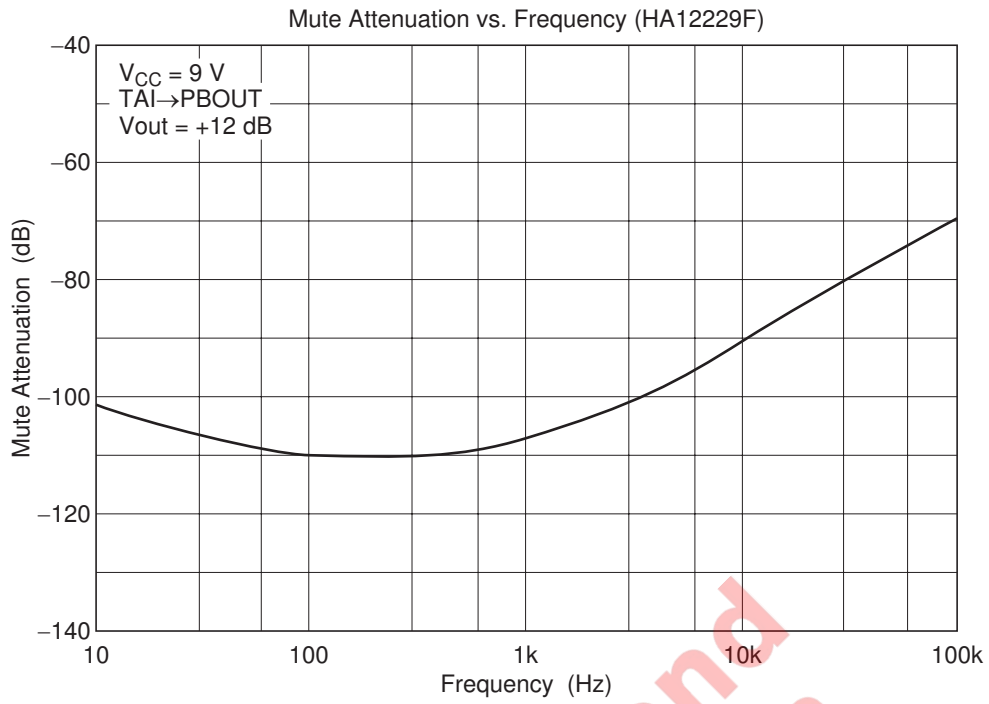

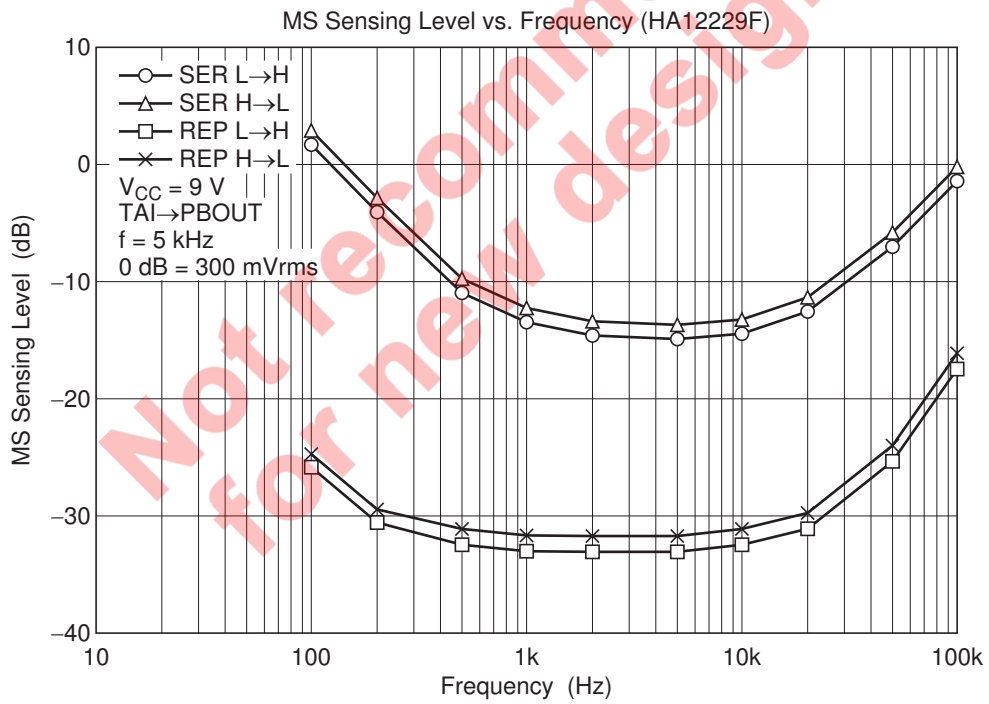
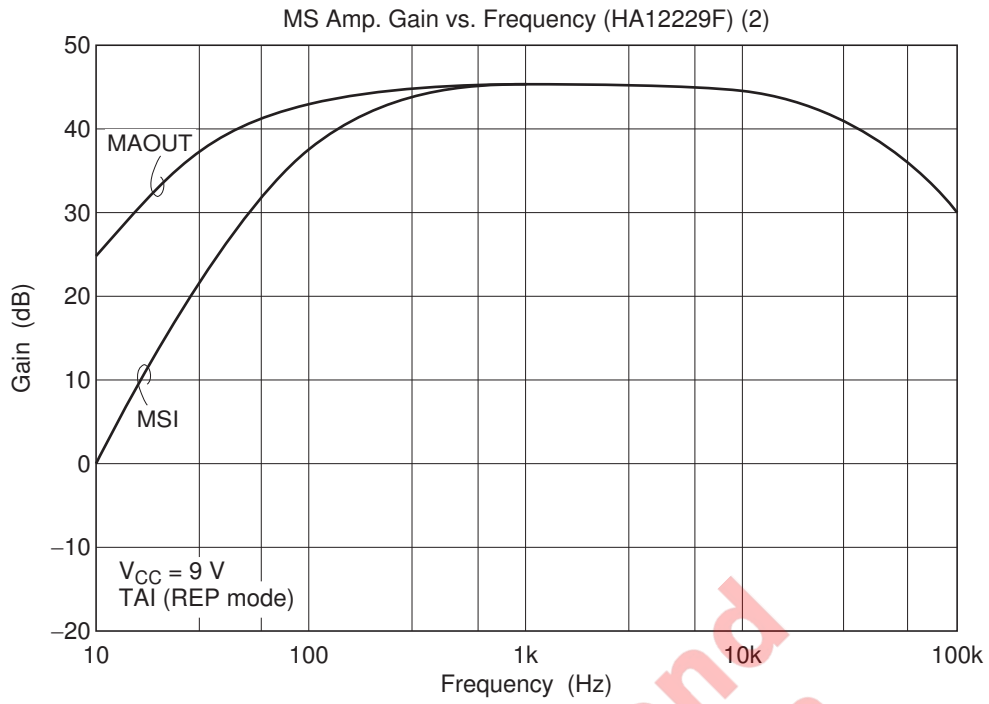

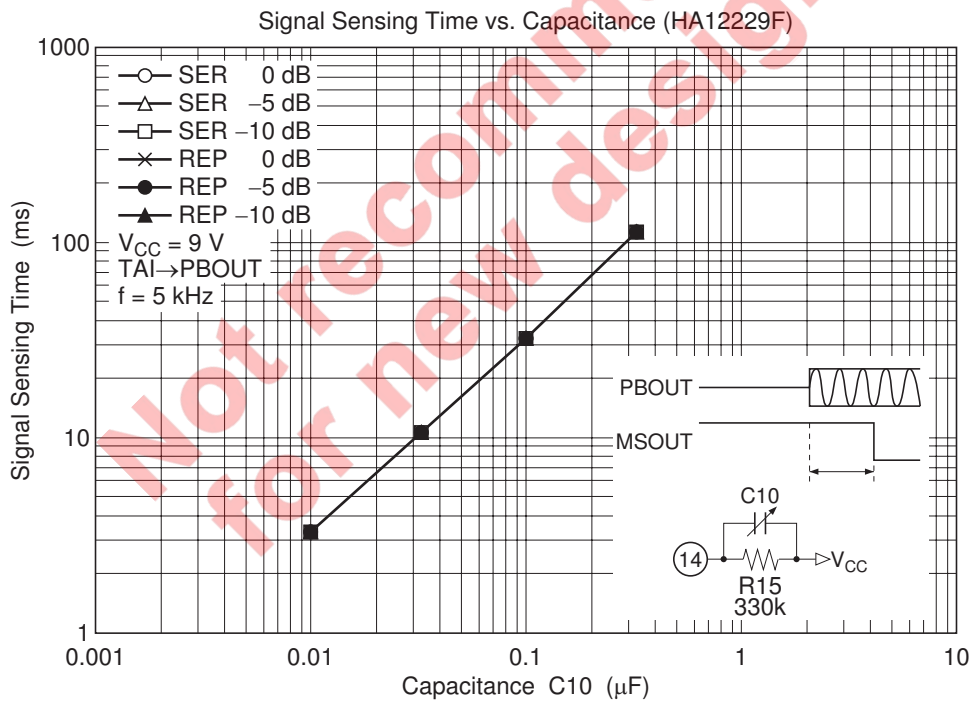
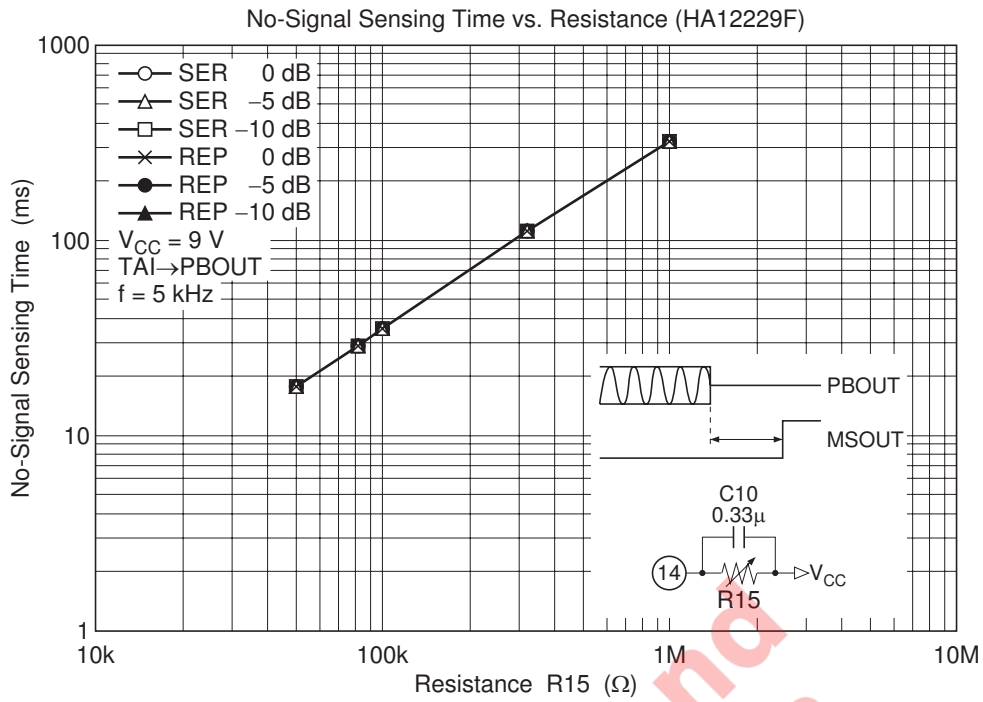

Package Dimensions

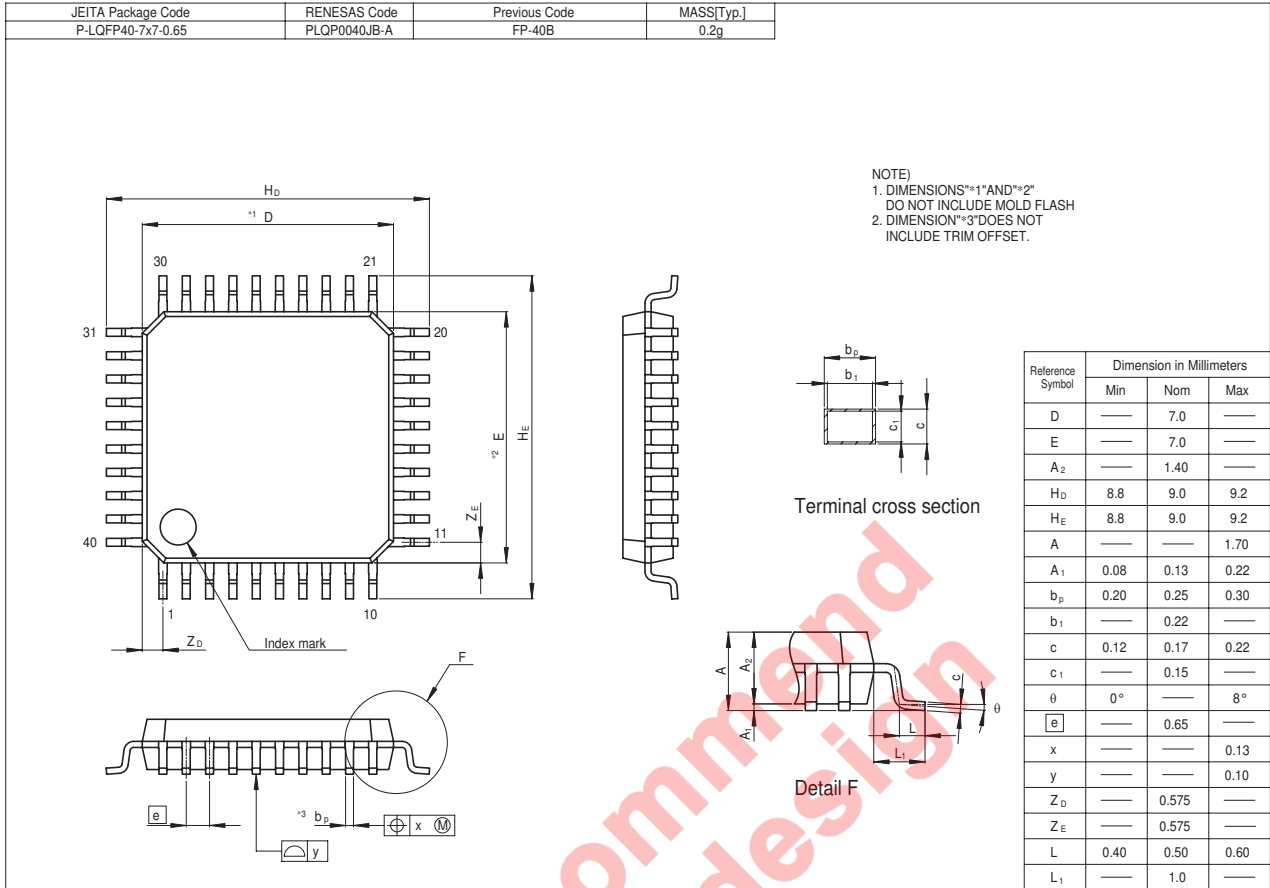

Not recommended for new design

Renesas Technology Corp. Sales Strategic Planning Div. Nippon Bldg., 2-6-2, Ohte-machi, Chiyoda-ku, Tokyo 100-0004, Japan

Keep safety first in your circuit designs!

1. Renesas Technology Corp. puts the maximum effort into making semiconductor products better and more reliable, but there is always the possibility that trouble may occur with them. Trouble with semiconductors may lead to personal injury, fire or property damage.
Remember to give due consideration to safety when making your circuit designs, with appropriate measures such as (i) placement of substitutive, auxiliary circuits, (ii) use of nonflammable material or (iii) prevention against any malfunction or mishap.

Notes regarding these materials

1. These materials are intended as a reference to assist our customers in the selection of the Renesas Technology Corp. product best suited to the customer's application; they do not convey any license under any intellectual property rights, or any other rights, belonging to Renesas Technology Corp. or a third party.
2. Renesas Technology Corp. assumes no responsibility for any damage, or infringement of any third-party's rights, originating in the use of any product data, diagrams, charts, programs, algorithms, or circuit application examples contained in these materials.
3. All information contained in these materials, including product data, diagrams, charts, programs and algorithms represents information on products at the time of publication of these materials, and are subject to change by Renesas Technology Corp. without notice due to product improvements or other reasons. It is therefore recommended that customers contact Renesas Technology Corp. or an authorized Renesas Technology Corp. product distributor for the latest product information before purchasing a product listed herein.
The information described here may contain technical inaccuracies or typographical errors.
Renesas Technology Corp. assumes no responsibility for any damage, liability, or other loss rising from these inaccuracies or errors.
Please also pay attention to information published by Renesas Technology Corp. by various means, including the Renesas Technology Corp. Semiconductor home page (<http://www.renesas.com>).
4. When using any or all of the information contained in these materials, including product data, diagrams, charts, programs, and algorithms, please be sure to evaluate all information as a total system before making a final decision on the applicability of the information and products. Renesas Technology Corp. assumes no responsibility for any damage, liability or other loss resulting from the information contained herein.
5. Renesas Technology Corp. semiconductors are not designed or manufactured for use in a device or system that is used under circumstances in which human life is potentially at stake. Please contact Renesas Technology Corp. or an authorized Renesas Technology Corp. product distributor when considering the use of a product contained herein for any specific purposes, such as apparatus or systems for transportation, vehicular, medical, aerospace, nuclear, or undersea repeater use.
6. The prior written approval of Renesas Technology Corp. is necessary to reprint or reproduce in whole or in part these materials.
7. If these products or technologies are subject to the Japanese export control restrictions, they must be exported under a license from the Japanese government and cannot be imported into a country other than the approved destination.
Any diversion or reexport contrary to the export control laws and regulations of Japan and/or the country of destination is prohibited.
8. Please contact Renesas Technology Corp. for further details on these materials or the products contained therein.



RENESAS SALES OFFICES

<http://www.renesas.com>

Refer to "<http://www.renesas.com/en/network>" for the latest and detailed information.

Renesas Technology America, Inc.
450 Holger Way, San Jose, CA 95134-1368, U.S.A
Tel: <1> (408) 382-7500, Fax: <1> (408) 382-7501

Renesas Technology Europe Limited
Dukes Meadow, Millboard Road, Bourne End, Buckinghamshire, SL8 5FH, U.K.
Tel: <44> (1628) 585-100, Fax: <44> (1628) 585-900

Renesas Technology Hong Kong Ltd.
7th Floor, North Tower, World Finance Centre, Harbour City, 1 Canton Road, Tsimshatsui, Kowloon, Hong Kong
Tel: <852> 2265-6688, Fax: <852> 2730-6071

Renesas Technology Taiwan Co., Ltd.
10th Floor, No.99, Fushing North Road, Taipei, Taiwan
Tel: <886> (2) 2715-2888, Fax: <886> (2) 2713-2999

Renesas Technology (Shanghai) Co., Ltd.
Unit2607 Ruijing Building, No.205 Maoming Road (S), Shanghai 200020, China
Tel: <86> (21) 6472-1001, Fax: <86> (21) 6415-2952

Renesas Technology Singapore Pte. Ltd.
1 Harbour Front Avenue, #06-10, Keppel Bay Tower, Singapore 098632
Tel: <65> 6213-0200, Fax: <65> 6278-8001