

To our customers,

Old Company Name in Catalogs and Other Documents

On April 1st, 2010, NEC Electronics Corporation merged with Renesas Technology Corporation, and Renesas Electronics Corporation took over all the business of both companies. Therefore, although the old company name remains in this document, it is a valid Renesas Electronics document. We appreciate your understanding.

Renesas Electronics website: <http://www.renesas.com>

April 1st, 2010
Renesas Electronics Corporation

Issued by: Renesas Electronics Corporation (<http://www.renesas.com>)

Send any inquiries to <http://www.renesas.com/inquiry>.

Not recommended
for new design

Notice

1. All information included in this document is current as of the date this document is issued. Such information, however, is subject to change without any prior notice. Before purchasing or using any Renesas Electronics products listed herein, please confirm the latest product information with a Renesas Electronics sales office. Also, please pay regular and careful attention to additional and different information to be disclosed by Renesas Electronics such as that disclosed through our website.
2. Renesas Electronics does not assume any liability for infringement of patents, copyrights, or other intellectual property rights of third parties by or arising from the use of Renesas Electronics products or technical information described in this document. No license, express, implied or otherwise, is granted hereby under any patents, copyrights or other intellectual property rights of Renesas Electronics or others.
3. You should not alter, modify, copy, or otherwise misappropriate any Renesas Electronics product, whether in whole or in part.
4. Descriptions of circuits, software and other related information in this document are provided only to illustrate the operation of semiconductor products and application examples. You are fully responsible for the incorporation of these circuits, software, and information in the design of your equipment. Renesas Electronics assumes no responsibility for any losses incurred by you or third parties arising from the use of these circuits, software, or information.
5. When exporting the products or technology described in this document, you should comply with the applicable export control laws and regulations and follow the procedures required by such laws and regulations. You should not use Renesas Electronics products or the technology described in this document for any purpose relating to military applications or use by the military, including but not limited to the development of weapons of mass destruction. Renesas Electronics products and technology may not be used for or incorporated into any products or systems whose manufacture, use, or sale is prohibited under any applicable domestic or foreign laws or regulations.
6. Renesas Electronics has used reasonable care in preparing the information included in this document, but Renesas Electronics does not warrant that such information is error free. Renesas Electronics assumes no liability whatsoever for any damages incurred by you resulting from errors in or omissions from the information included herein.
7. Renesas Electronics products are classified according to the following three quality grades: "Standard", "High Quality", and "Specific". The recommended applications for each Renesas Electronics product depends on the product's quality grade, as indicated below. You must check the quality grade of each Renesas Electronics product before using it in a particular application. You may not use any Renesas Electronics product for any application categorized as "Specific" without the prior written consent of Renesas Electronics. Further, you may not use any Renesas Electronics product for any application for which it is not intended without the prior written consent of Renesas Electronics. Renesas Electronics shall not be in any way liable for any damages or losses incurred by you or third parties arising from the use of any Renesas Electronics product for an application categorized as "Specific" or for which the product is not intended where you have failed to obtain the prior written consent of Renesas Electronics. The quality grade of each Renesas Electronics product is "Standard" unless otherwise expressly specified in a Renesas Electronics data sheets or data books, etc.
 - "Standard": Computers; office equipment; communications equipment; test and measurement equipment; audio and visual equipment; home electronic appliances; machine tools; personal electronic equipment; and industrial robots.
 - "High Quality": Transportation equipment (automobiles, trains, ships, etc.); traffic control systems; anti-disaster systems; anti-crime systems; safety equipment; and medical equipment not specifically designed for life support.
 - "Specific": Aircraft; aerospace equipment; submersible repeaters; nuclear reactor control systems; medical equipment or systems for life support (e.g. artificial life support devices or systems), surgical implantations, or healthcare intervention (e.g. excision, etc.), and any other applications or purposes that pose a direct threat to human life.
8. You should use the Renesas Electronics products described in this document within the range specified by Renesas Electronics, especially with respect to the maximum rating, operating supply voltage range, movement power voltage range, heat radiation characteristics, installation and other product characteristics. Renesas Electronics shall have no liability for malfunctions or damages arising out of the use of Renesas Electronics products beyond such specified ranges.
9. Although Renesas Electronics endeavors to improve the quality and reliability of its products, semiconductor products have specific characteristics such as the occurrence of failure at a certain rate and malfunctions under certain use conditions. Further, Renesas Electronics products are not subject to radiation resistance design. Please be sure to implement safety measures to guard them against the possibility of physical injury, and injury or damage caused by fire in the event of the failure of a Renesas Electronics product, such as safety design for hardware and software including but not limited to redundancy, fire control and malfunction prevention, appropriate treatment for aging degradation or any other appropriate measures. Because the evaluation of microcomputer software alone is very difficult, please evaluate the safety of the final products or system manufactured by you.
10. Please contact a Renesas Electronics sales office for details as to environmental matters such as the environmental compatibility of each Renesas Electronics product. Please use Renesas Electronics products in compliance with all applicable laws and regulations that regulate the inclusion or use of controlled substances, including without limitation, the EU RoHS Directive. Renesas Electronics assumes no liability for damages or losses occurring as a result of your noncompliance with applicable laws and regulations.
11. This document may not be reproduced or duplicated, in any form, in whole or in part, without prior written consent of Renesas Electronics.
12. Please contact a Renesas Electronics sales office if you have any questions regarding the information contained in this document or Renesas Electronics products, or if you have any other inquiries.

(Note 1) "Renesas Electronics" as used in this document means Renesas Electronics Corporation and also includes its majority-owned subsidiaries.

(Note 2) "Renesas Electronics product(s)" means any product developed or manufactured by or for Renesas Electronics.

HD74LS669

Synchronous Up / Down 4-bit Binary Counter

REJ03D0493-0200

Rev.2.00

Feb.18.2005

This synchronous preset table 4-bit binary counter features an internal carry look-ahead for cascading in high-speed counting applications. Synchronous operation is provided by having all flip-flops clocked simultaneously so that the outputs change coincident with each other when so instructed by the count-enable inputs and internal gating. This mode of operation helps eliminate the output counting spikes that are normally associated with asynchronous (ripple-clock) counters. A buffered clock input trigger the four master-slave flip-flops on the rising (positive-going) edge of the clock waveform. This counter is fully programmable; that is, the outputs may each be preset to either level. the load input circuitry allows loading with the carry-enable output of cascaded counters. As loading is synchronous, setting up a low level at the load input disables the counter and causes the outputs to agree with the data inputs after the next clock pulse. The carry look-ahead circuitry provides for cascading counters for n-bit synchronous applications without additional gating. Instrumental in accomplishing this function are two count enable inputs and a carry output. Both count enable inputs (\bar{P} and \bar{T}) must be low to count. The direction of the count is determined by the level of the up / down input. when the input is high, the counter counts up; when low, it counts down. Input \bar{T} is fed forward to enable the carry output. The carry output thus enabled will produce a low-level output pulse with a duration approximately equal to the high portion of the Q_A output when counting up and approximately equal to the low portion of the Q_A output when counting down. This low level overflow carry pulse can be used to enable successive cascaded stages.

Transitions at the enable \bar{P} or \bar{T} inputs are allowed regardless of the level of the clock input. All inputs are diode-clamped to minimize transmission-line effects, thereby simplifying system design. This counter features a fully independent clock circuit. Changes at control inputs (enable P, enable T, load, up / down) that will modify the operating mode have no effect until clocking occurs. The function of the counter (whether enabled, disabled, loading, or counting) will be dictated solely by the conditions meeting the stable setup and hold times.

Features

- Ordering Information

Part Name	Package Type	Package Code (Previous Code)	Package Abbreviation	Taping Abbreviation (Quantity)
HD74LS669FPEL	SOP-16 pin (JEITA)	PRSP0016DH-B (FP-16DAV)	FP	EL (2,000 pcs/reel)

Note: Please consult the sales office for the above package availability.

Pin Arrangement

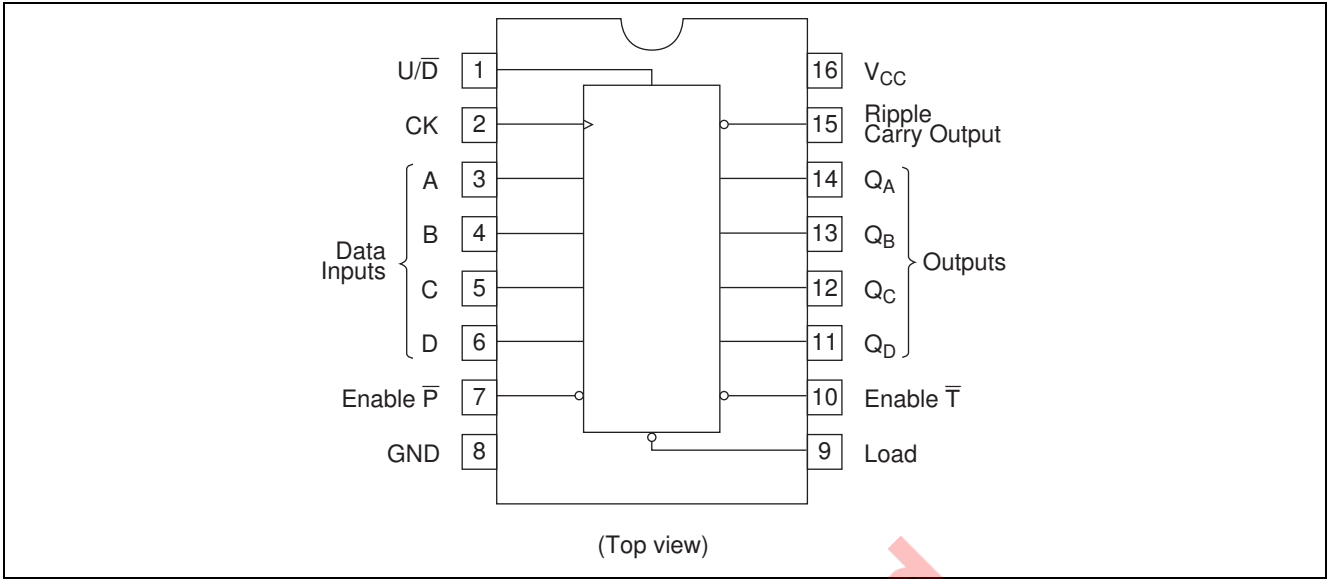

Block Diagram

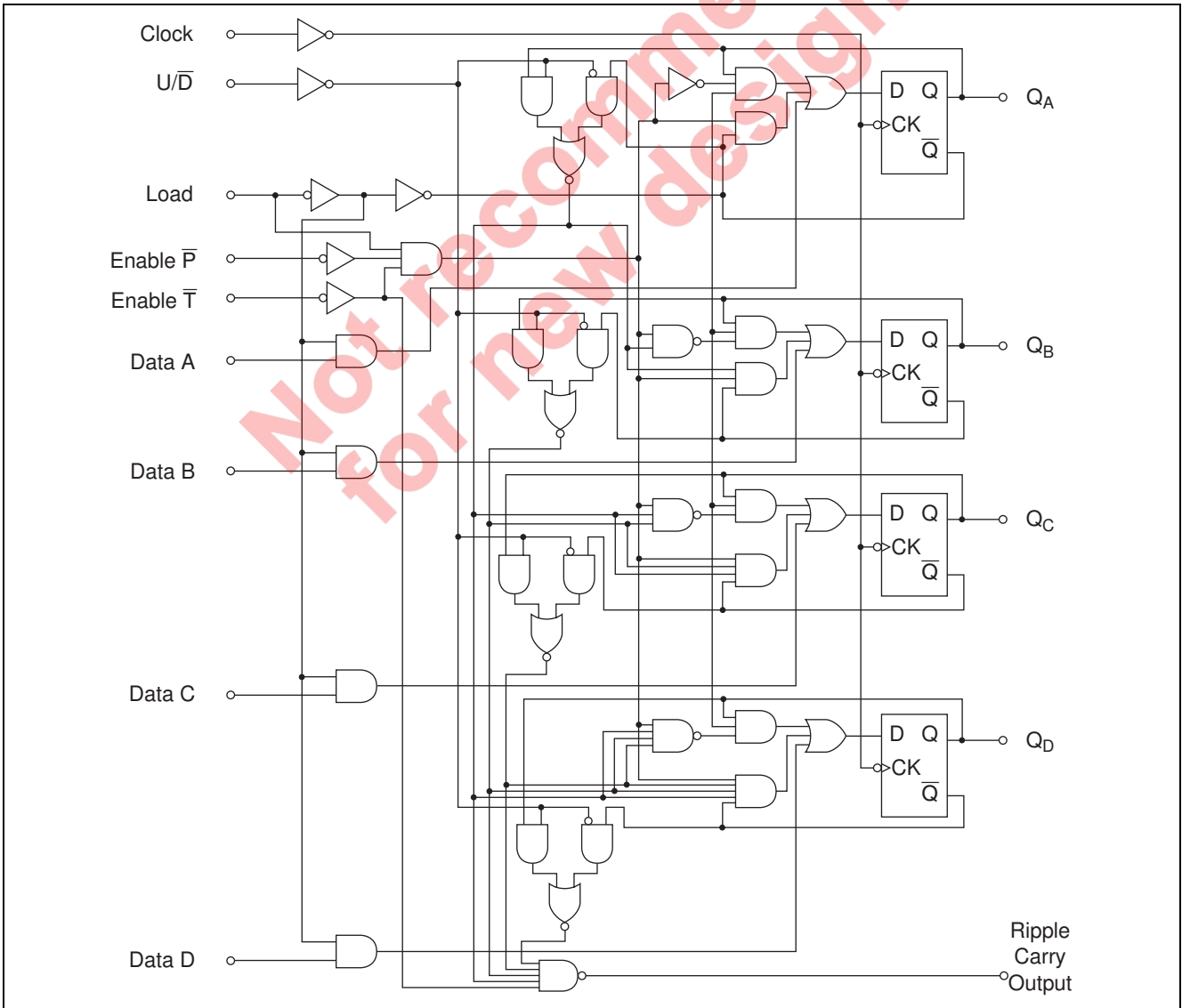

Absolute Maximum Ratings

Item	Symbol	Ratings	Unit
Supply voltage	V_{CC}	7	V
Input voltage	V_{IN}	7	V
Power dissipation	P_T	400	mW
Storage temperature	T_{stg}	-65 to +150	°C

Note: Voltage value, unless otherwise noted, are with respect to network ground terminal.

Recommended Operating Conditions

Item	Symbol	Min	Typ	Max	Unit	
Supply voltage	V_{CC}	4.75	5.00	5.25	V	
Output current	I_{OH}	—	—	-400	μA	
	I_{OL}	—	—	8	mA	
Operating temperature	T_{opr}	-20	25	75	°C	
Count frequency	f_{count}	0	—	25	MHz	
Clock pulse width	$t_w (CK)$	25	—	—	ns	
Setup time	Input Data A, B, C, D	t_{su}	25	—	—	ns
	Enable \bar{P} , \bar{T}		35	—	—	
	Load		30	—	—	
	Up/Down		35	—	—	
Hold time	t_h	0	—	—	ns	

Electrical Characteristics

($T_a = -20$ to $+75$ °C)

Item	Symbol	min.	typ.*	max.	Unit	Condition	
Input voltage	V_{IH}	2.0	—	—	V		
	V_{IL}	—	—	0.8	V		
Output voltage	V_{OH}	2.7	—	—	V	$V_{CC} = 4.75$ V, $V_{IH} = 2$ V, $V_{IL} = 0.8$ V, $I_{OH} = -400$ μA	
	V_{OL}	—	—	0.4	V	$I_{OL} = 4$ mA	
—		—	0.5	V	$I_{OL} = 8$ mA	$V_{CC} = 4.75$ V, $V_{IH} = 2$ V, $V_{IL} = 0.8$ V	
Input current	A, B, C, D, \bar{P} , \bar{U}/\bar{D}	I_{IH}	—	—	20	μA	$V_{CC} = 5.25$ V, $V_I = 2.7$ V
	Clock, \bar{T}		—	—	20		
	Load		—	—	40		
	A, B, C, D, \bar{P} , \bar{U}/\bar{D}	I_{IL}	—	—	-0.4	mA	$V_{CC} = 5.25$ V, $V_I = 0.4$ V
	Clock, \bar{T}		—	—	-0.4		
	Load		—	—	-0.8		
	A, B, C, D, \bar{P} , \bar{U}/\bar{D}	I_I	—	—	0.1	mA	$V_{CC} = 5.25$ V, $V_I = 7$ V
Clock, \bar{T}	—		—	0.1			
Load	—		—	0.2			
Short-circuit output current	I_{OS}	-20	—	-100	mA	$V_{CC} = 5.25$ V	
Supply current**	I_{CC}	—	20	34	mA	$V_{CC} = 5.25$ V	
Input clamp voltage	V_{IK}	—	—	-1.5	V	$V_{CC} = 4.75$ V, $I_{IN} = -18$ mA	

Notes: * $V_{CC} = 5$ V, $T_a = 25$ °C

** I_{CC} is measured after applying a momentary 4.5 V, then ground, to clock input with all other inputs grounded the outputs open.

Switching Characteristics

($V_{CC} = 5\text{ V}$, $T_a = 25^\circ\text{C}$)

Item	Symbol	Inputs	Outputs	min.	typ.	max.	Unit	Condition
Maximum clock frequency	f_{max}			25	32	—	MHz	
Propagation delay time	t_{PLH}	Clock	Ripple Carry	—	26	40	ns	$C_L = 15\text{ pF}$, $R_L = 2\text{ k}\Omega$
	t_{PHL}			—	40	60		
	t_{PLH}	Clock	Q_A to Q_D	—	18	27	ns	
	t_{PHL}			—	18	27		
	t_{PLH}	Enable \bar{T}	Ripple Carry	—	11	17	ns	
	t_{PHL}			—	29	45		
	t_{PLH}	Up/Down	Ripple Carry	—	22	35	ns	
	t_{PHL}			—	26	40		

Count Sequence

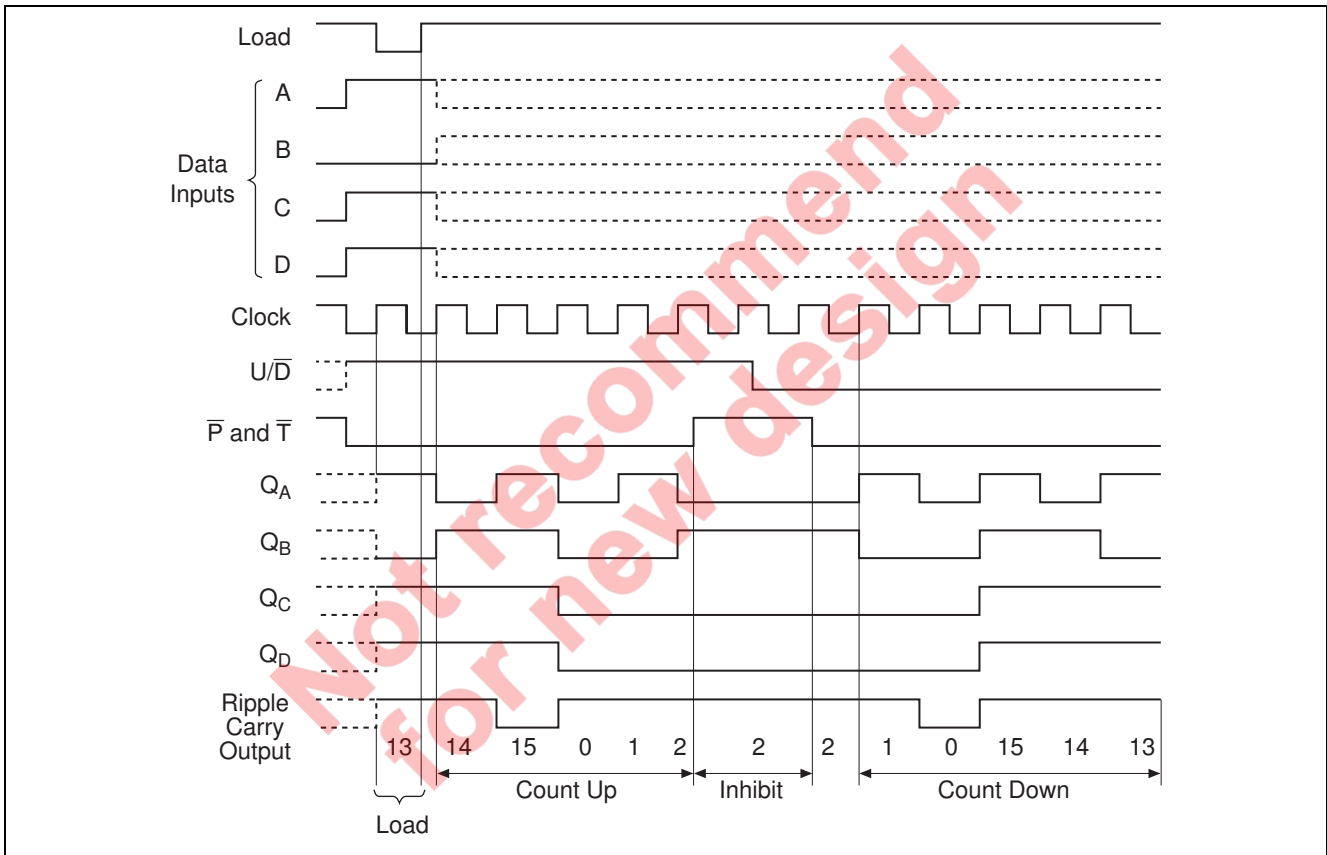

Testing Method

Test Circuit

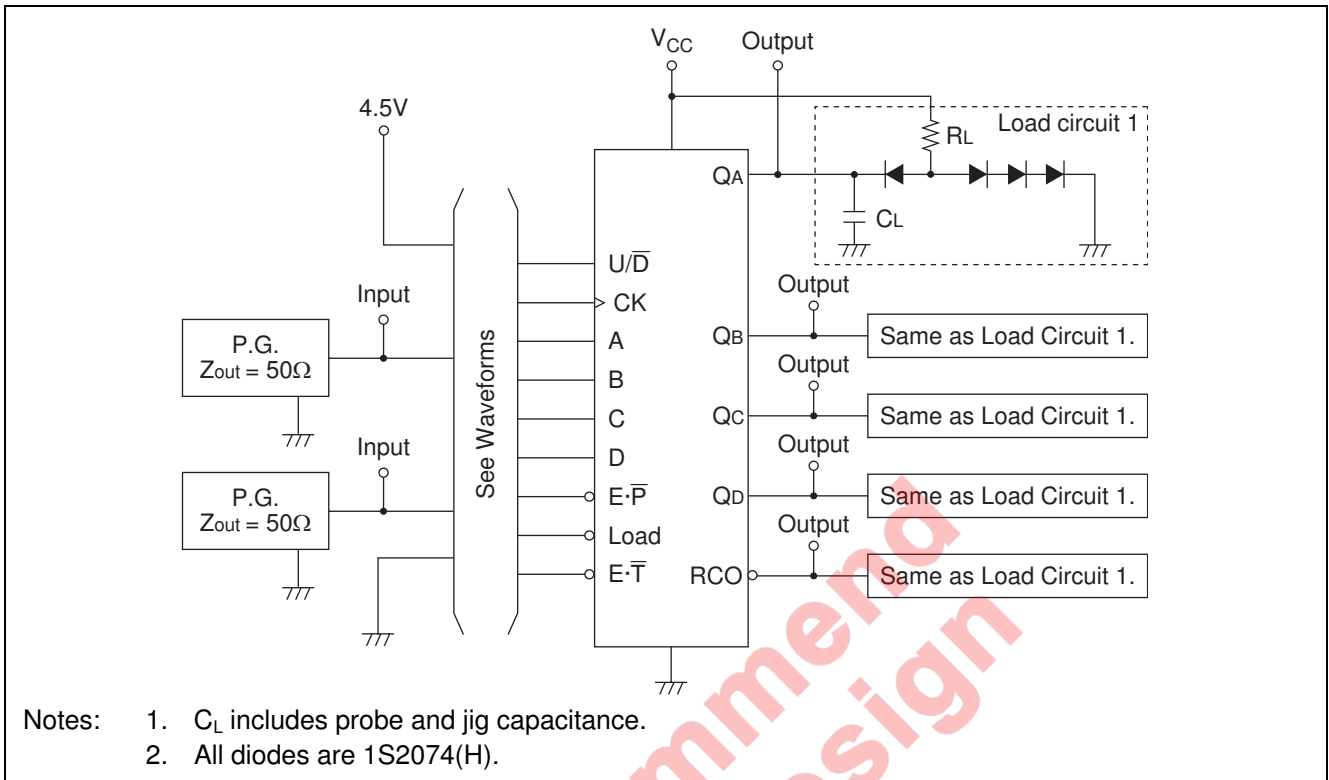

Waveforms 1

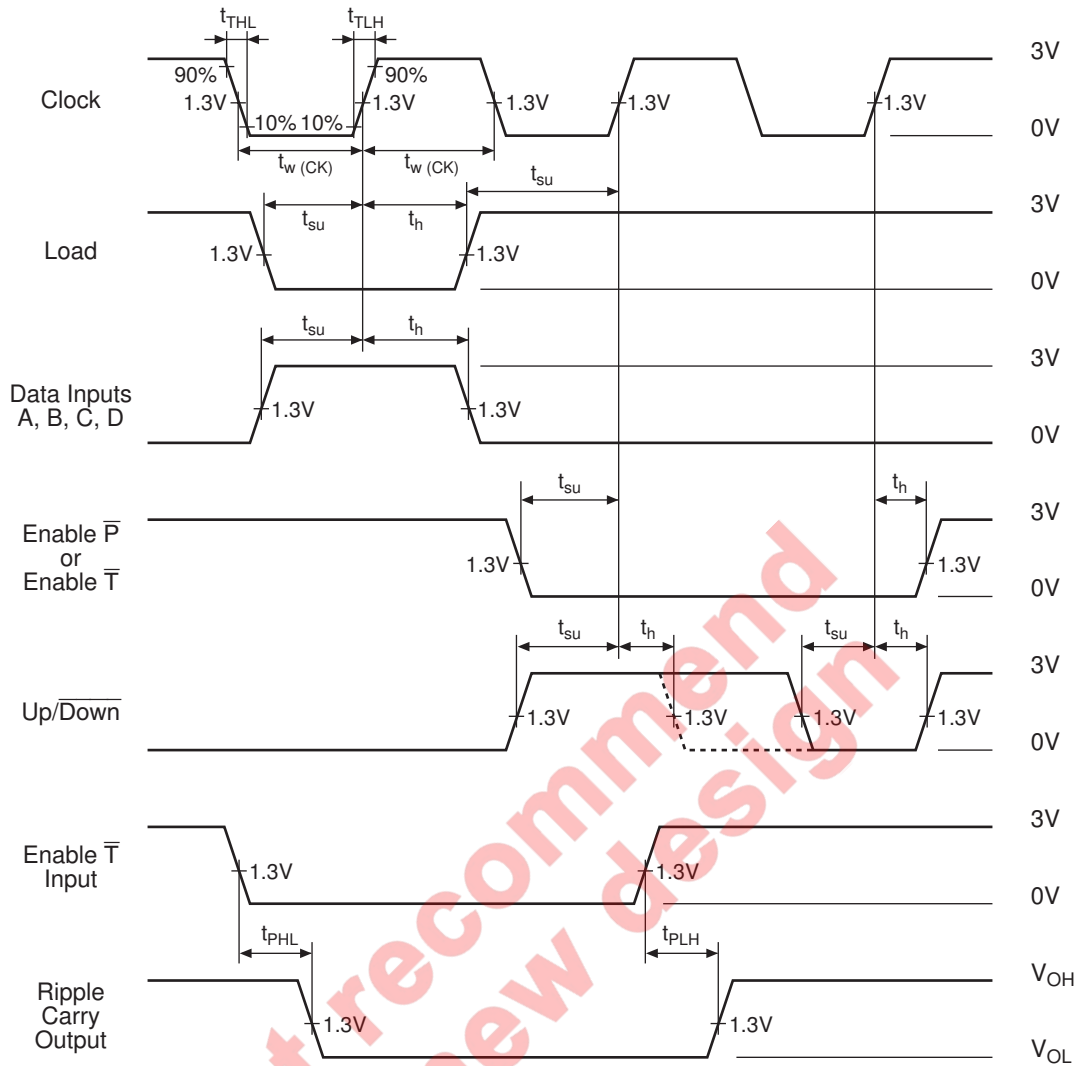

- Notes:
1. t_{PLH} and t_{PHL} from enable \bar{T} input to ripple carry output assume that the counter is at the maximum count (Q_A through Q_D high).
 2. Propagation delay time from up / down to ripple carry must be measured with the counter at either a minimum or a maximum count. As the logic level of the up / down input is changed, the ripple carry output will follow. If the count is minimum (0) the ripple carry output transition will be in phase. If the count is maximum (15) the ripple carry output will be out of phase.
 3. Input pulse; $t_{TLH} \leq 15$ ns, $t_{THL} \leq 6$ ns, PRR = 1 MHz

Waveforms 2

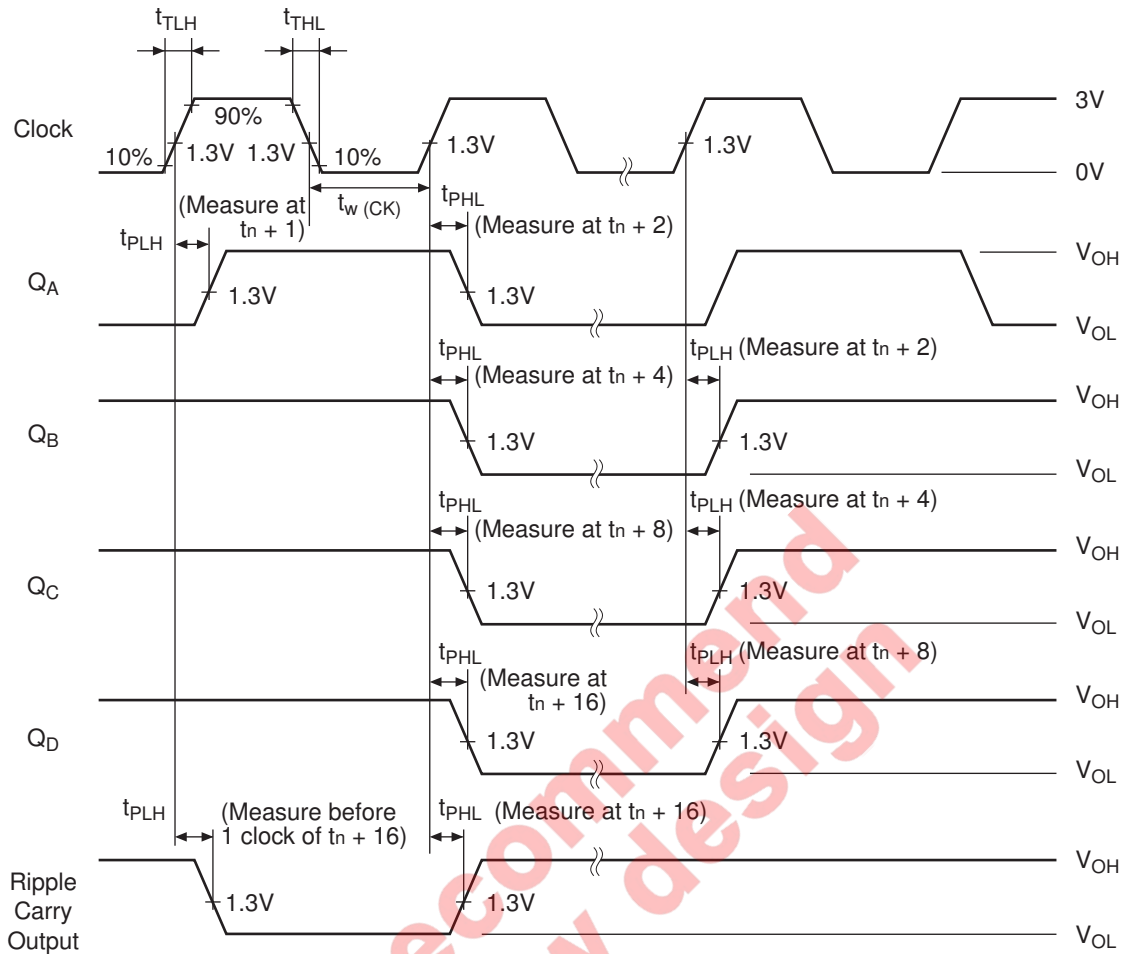

- Notes:
1. Input pulse; $t_{TLH} \leq 15$ ns, $t_{THL} \leq 6$ ns, PRR = 1 MHz, duty cycle 50%.
 2. For f_{max} $t_{TLH} = t_{THL} \leq 2.5$ ns.
 3. t_n is the bit-time when all outputs are low.

Package Dimensions

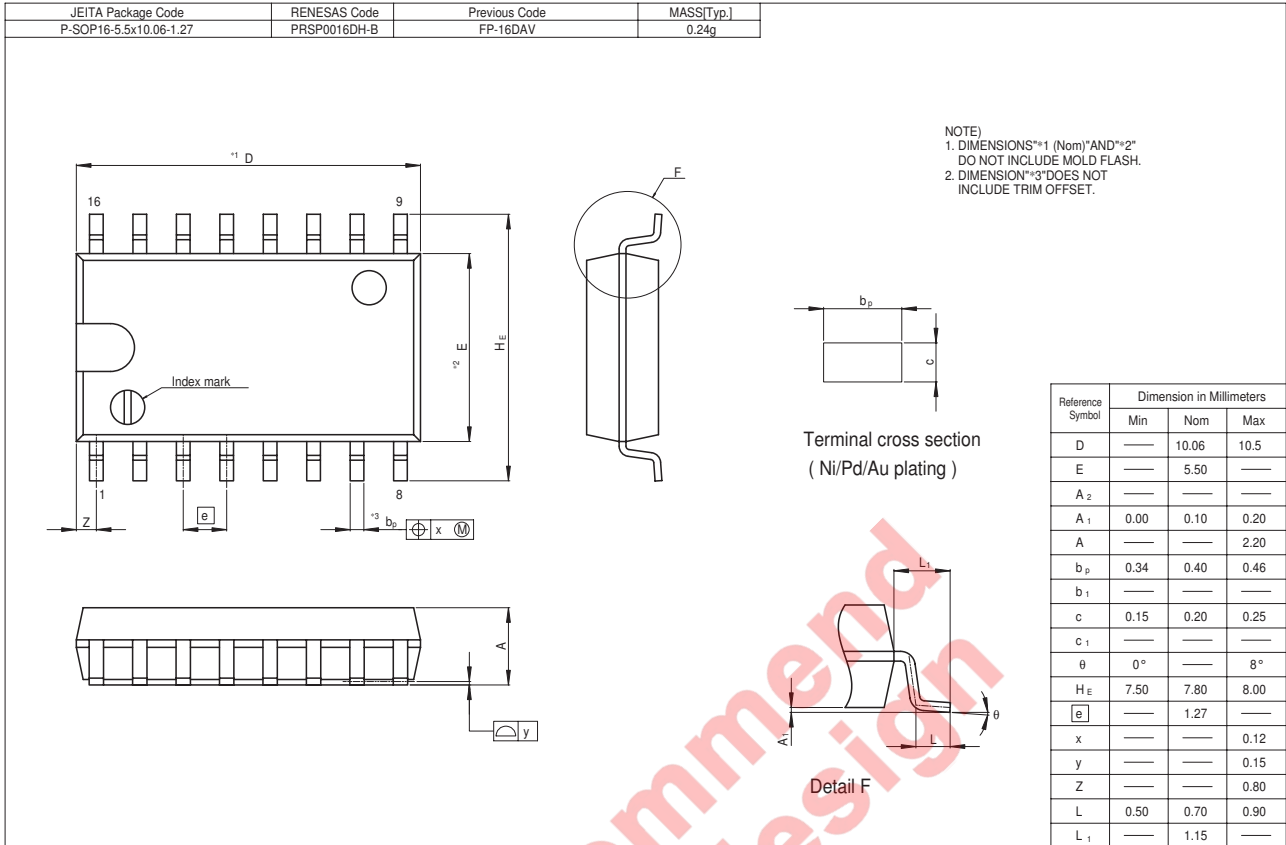

Not recommended
 for new design

Renesas Technology Corp. Sales Strategic Planning Div. Nippon Bldg., 2-6-2, Ohte-machi, Chiyoda-ku, Tokyo 100-0004, Japan

Keep safety first in your circuit designs!

1. Renesas Technology Corp. puts the maximum effort into making semiconductor products better and more reliable, but there is always the possibility that trouble may occur with them. Trouble with semiconductors may lead to personal injury, fire or property damage.
Remember to give due consideration to safety when making your circuit designs, with appropriate measures such as (i) placement of substitutive, auxiliary circuits, (ii) use of nonflammable material or (iii) prevention against any malfunction or mishap.

Notes regarding these materials

1. These materials are intended as a reference to assist our customers in the selection of the Renesas Technology Corp. product best suited to the customer's application; they do not convey any license under any intellectual property rights, or any other rights, belonging to Renesas Technology Corp. or a third party.
 2. Renesas Technology Corp. assumes no responsibility for any damage, or infringement of any third-party's rights, originating in the use of any product data, diagrams, charts, programs, algorithms, or circuit application examples contained in these materials.
 3. All information contained in these materials, including product data, diagrams, charts, programs and algorithms represents information on products at the time of publication of these materials, and are subject to change by Renesas Technology Corp. without notice due to product improvements or other reasons. It is therefore recommended that customers contact Renesas Technology Corp. or an authorized Renesas Technology Corp. product distributor for the latest product information before purchasing a product listed herein.
The information described here may contain technical inaccuracies or typographical errors.
Renesas Technology Corp. assumes no responsibility for any damage, liability, or other loss rising from these inaccuracies or errors.
Please also pay attention to information published by Renesas Technology Corp. by various means, including the Renesas Technology Corp. Semiconductor home page (<http://www.renesas.com>).
 4. When using any or all of the information contained in these materials, including product data, diagrams, charts, programs, and algorithms, please be sure to evaluate all information as a total system before making a final decision on the applicability of the information and products. Renesas Technology Corp. assumes no responsibility for any damage, liability or other loss resulting from the information contained herein.
 5. Renesas Technology Corp. semiconductors are not designed or manufactured for use in a device or system that is used under circumstances in which human life is potentially at stake. Please contact Renesas Technology Corp. or an authorized Renesas Technology Corp. product distributor when considering the use of a product contained herein for any specific purposes, such as apparatus or systems for transportation, vehicular, medical, aerospace, nuclear, or undersea repeater use.
 6. The prior written approval of Renesas Technology Corp. is necessary to reprint or reproduce in whole or in part these materials.
 7. If these products or technologies are subject to the Japanese export control restrictions, they must be exported under a license from the Japanese government and cannot be imported into a country other than the approved destination.
Any diversion or reexport contrary to the export control laws and regulations of Japan and/or the country of destination is prohibited.
 8. Please contact Renesas Technology Corp. for further details on these materials or the products contained therein.
-



RENESAS SALES OFFICES

<http://www.renesas.com>

Refer to "<http://www.renesas.com/en/network>" for the latest and detailed information.

Renesas Technology America, Inc.
450 Holger Way, San Jose, CA 95134-1368, U.S.A
Tel: <1> (408) 382-7500, Fax: <1> (408) 382-7501

Renesas Technology Europe Limited
Dukes Meadow, Millboard Road, Bourne End, Buckinghamshire, SL8 5FH, U.K.
Tel: <44> (1628) 585-100, Fax: <44> (1628) 585-900

Renesas Technology Hong Kong Ltd.
7th Floor, North Tower, World Finance Centre, Harbour City, 1 Canton Road, Tsimshatsui, Kowloon, Hong Kong
Tel: <852> 2265-6688, Fax: <852> 2730-6071

Renesas Technology Taiwan Co., Ltd.
10th Floor, No.99, Fushing North Road, Taipei, Taiwan
Tel: <886> (2) 2715-2888, Fax: <886> (2) 2713-2999

Renesas Technology (Shanghai) Co., Ltd.
Unit2607 Ruijing Building, No.205 Maoming Road (S), Shanghai 200020, China
Tel: <86> (21) 6472-1001, Fax: <86> (21) 6415-2952

Renesas Technology Singapore Pte. Ltd.
1 Harbour Front Avenue, #06-10, Keppel Bay Tower, Singapore 098632
Tel: <65> 6213-0200, Fax: <65> 6278-8001