



# LIN System Basis Chip with DC Motor Pre-driver and Current Sense

The 33912G5/BAC is a Serial Peripheral Interface (SPI) controlled System Basis Chip (SBC), combining many frequently used functions in an MCU based system, plus a Local Interconnect Network (LIN) transceiver. The 33912 has a 5.0 V, 50 mA/60 mA low dropout regulator with full protection and reporting features. The device provides full SPI readable diagnostics and a selectable timing watchdog for detecting errant operation. The LIN Protocol Specification 2.0 and 2.1 compliant LIN transceiver has waveshaping circuitry that can be disabled for higher data rates.

Two 50 mA/60 mA high side switches and two 150 mA/160 mA low side switches with output protection are available. All outputs can be pulse-width modulated (PWM). Four high voltage inputs are available for use in contact monitoring, or as external wake-up inputs. These inputs can be used as high voltage Analog Inputs. The voltage on these pins is divided by a selectable ratio and available via an analog multiplexer.

The 33912 has three main operating modes: Normal (all functions available), Sleep ( $V_{DD}$  off, wake-up via LIN, wake-up inputs (L1-L4), cyclic sense and forced wake-up), and Stop ( $V_{DD}$  on with limited current capability, wake-up via CS, LIN bus, wake-up inputs, cyclic sense, forced wake-up and external reset).

The 33912 is compatible with LIN Protocol Specification 2.0, 2.1, and SAEJ2602-2.

## Features

- Full-duplex SPI interface at frequencies up to 4.0 MHz
- LIN transceiver capable of up to 100 kbps with wave shaping
- Current sense module
- Four high voltage analog/logic Inputs
- Configurable window watchdog
- Switched/protected 5.0 V output (used for Hall sensors)
- Two 50 mA high side and two 150 mA/160 mA low side protected switches
- 5.0 V low drop regulator with fault detection and low voltage reset (LVR) circuitry
- Pb-free packaging designated by suffix code AC

**33912**

**SYSTEM BASIS CHIP WITH LIN  
2<sup>ND</sup> GENERATION**

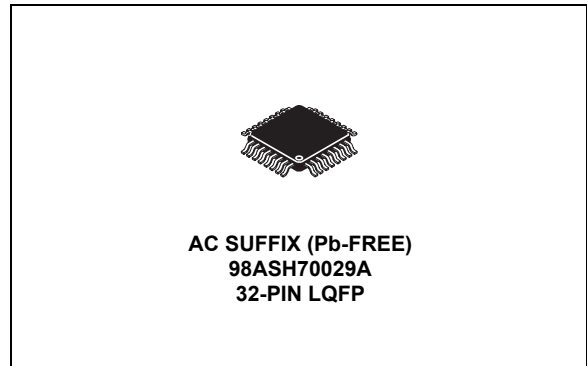

ORDERING INFORMATION		
Device	Temperature Range (T <sub>A</sub> )	Package
MC33912G5AC/R2	-40°C to 125°C	32-LQFP
MC34912G5AC/R2	-40°C to 85°C	
MC33912BAC/R2	-40°C to 125°C	
MC34912BAC/R2	-40°C to 85°C	

\* See Page 2 for Device Variations

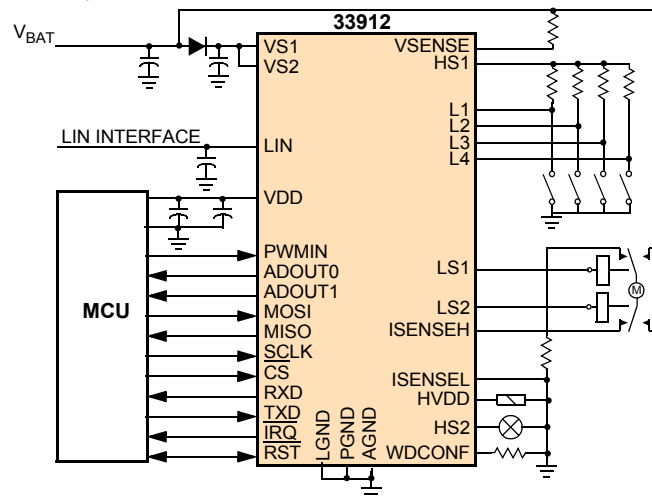

Figure 1. 33912 Simplified Application Diagram

\* This document contains certain information on a new product. Specifications and information herein are subject to change without notice.

## DEVICE VARIATIONS

The 33912G5 data sheet is within [MC33912G5 Product Specifications Pages 3 to 47](#)

The 33912BAC data sheet is within [MC33912BAC Product Specifications Pages 48 to 90](#)

**Table 1. Device Variations for the MC33912**

Device	Temperature	Generation	Changes
MC33912G5AC/R2	-40°C to 125°C	2.5	<ol style="list-style-type: none"> <li>1. Increase ESD Gun IEC61000-4-2 (gun test contact with 150 pF, 330 ohm test conditions) performance to achieve ±6.0 kV min on the LIN pin.</li> <li>2. Immunity against ISO7637 pulse 3b</li> <li>3. Reduce EMC emission level on LIN</li> <li>4. Improve EMC immunity against RF - target new specification including 3x68pF</li> <li>5. Comply with J2602 conformance test</li> </ol>
MC34912G5AC/R2	-40°C to 85°C		
MC33912BAC/R2	-40°C to 125°C	2.0	Initial release
MC34912BAC/R2	-40°C to 85°C		

**MC33912G5 PRODUCT SPECIFICATIONS  
PAGES 3 TO 47**

**INTERNAL BLOCK DIAGRAM**

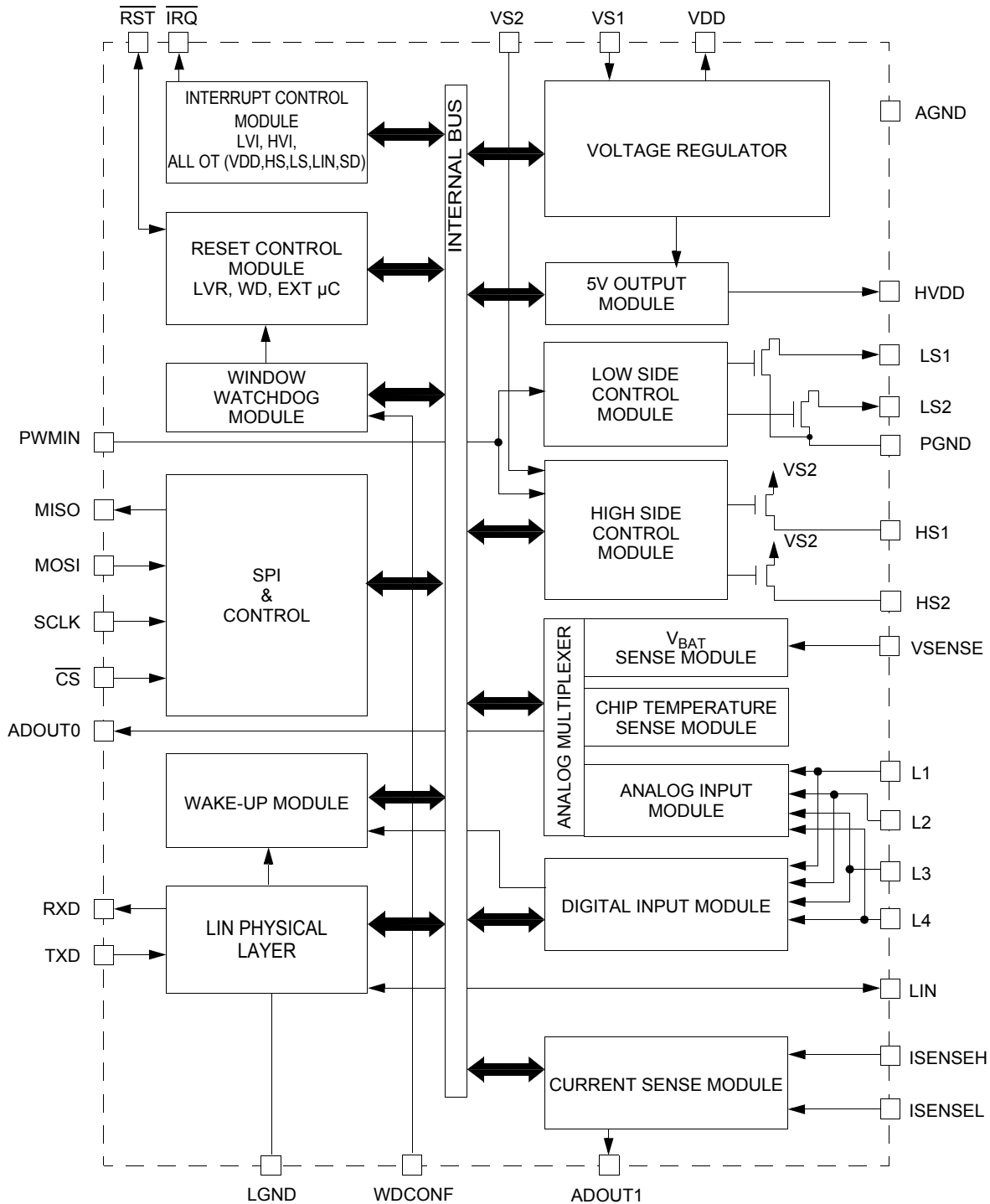

**Figure 2. 33912 Simplified Internal Block Diagram**

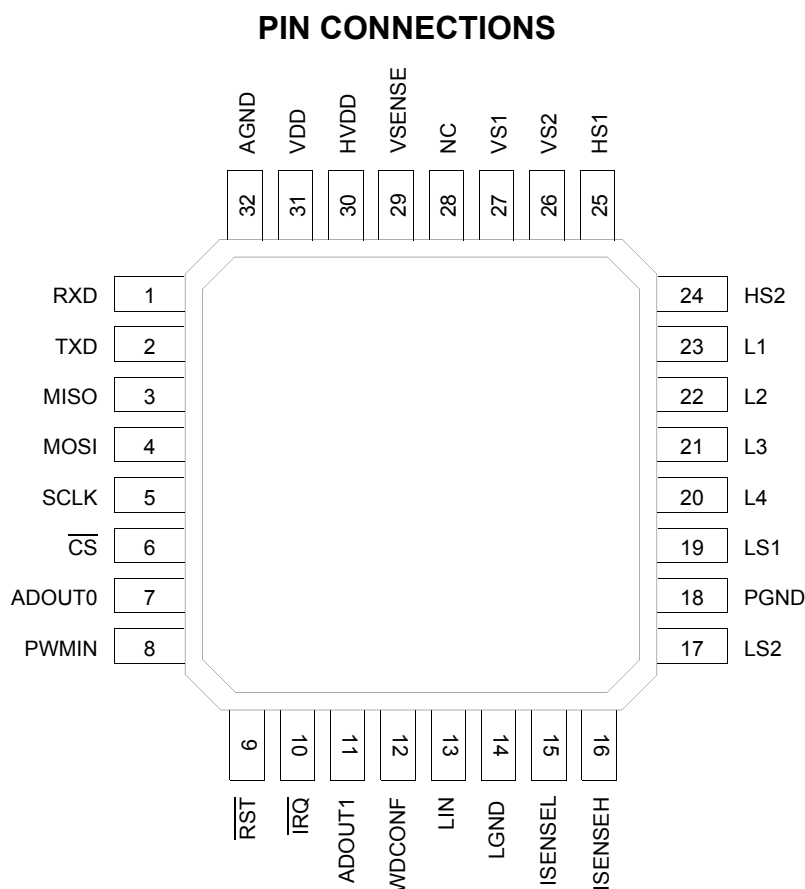

Figure 3. 33912 Pin Connections

Table 2. 33912 Pin Definitions

A functional description of each pin can be found in the [Functional Pin Description](#) section beginning on [page 24](#).

Pin	Pin Name	Formal Name	Definition
1	RXD	Receiver Output	This pin is the receiver output of the LIN interface which reports the state of the bus voltage to the MCU interface.
2	TXD	Transmitter Input	This pin is the transmitter input of the LIN interface which controls the state of the bus output.
3	MISO	SPI Output	SPI (Serial Peripheral Interface) data output. When $\overline{CS}$ is high, pin is in the high-impedance state.
4	MOSI	SPI Input	SPI (Serial Peripheral Interface) data input.
5	SCLK	SPI Clock	SPI (Serial Peripheral Interface) clock Input.
6	$\overline{CS}$	SPI Chip Select	SPI (Serial Peripheral Interface) chip select input pin. $\overline{CS}$ is active low.
7	ADOUT0	Analog Output Pin 0	Analog Multiplexer Output.
8	PWMIN	PWM Input	High Side and Low Side Pulse Width Modulation Input.
9	$\overline{RST}$	Internal Reset I/O	Bidirectional Reset I/O pin - driven low when any internal reset source is asserted. $\overline{RST}$ is active low.
10	$\overline{IRQ}$	Internal Interrupt Output	Interrupt output pin, indicating wake-up events from Stop mode or events from Normal and Normal request modes. $\overline{IRQ}$ is active low.
11	ADOUT1	Analog Output Pin 1	Current sense analog output.

**Table 2. 33912 Pin Definitions**

A functional description of each pin can be found in the [Functional Pin Description](#) section beginning on [page 24](#).

Pin	Pin Name	Formal Name	Definition
12	WDCONF	Watchdog Configuration Pin	This input pin is for configuration of the watchdog period and allows the disabling of the watchdog.
13	LIN	LIN Bus	This pin represents the single-wire bus transmitter and receiver.
14	LGND	LIN Ground Pin	This pin is the device LIN ground connection. It is internally connected to the PGND pin.
15	ISENSEL	Current Sense Pins	Current Sense differential inputs.
16	ISENSEH		
17	LS2	Low Side Outputs	Relay drivers low side outputs.
19	LS1		
18	PGND	Power Ground Pin	This pin is the device low side ground connection. It is internally connected to the LGND pin.
20	L4	Wake-up Inputs	These pins are the wake-up capable digital inputs <sup>(1)</sup> . In addition, all Lx inputs can be sensed analog via the analog multiplexer.
21	L3		
22	L2		
23	L1		
24	HS2	High Side Outputs	High side switch outputs.
25	HS1		
26	VS2	Power Supply Pin	These pins are device battery level power supply pins. VS2 is supplying the HSx drivers while VS1 supplies the remaining blocks. <sup>(2)</sup>
27	VS1		
28	NC	Not Connected	This pin can be left open or connected to any potential ground or power supply.
29	VSENSE	Voltage Sense Pin	Battery voltage sense input. <sup>(3)</sup>
30	HVDD	Hall Sensor Supply Output	+5.0 V switchable supply output pin. <sup>(4)</sup>
31	VDD	Voltage Regulator Output	+5.0 V main voltage regulator output pin. <sup>(5)</sup>
32	AGND	Analog Ground Pin	This pin is the device analog ground connection.

**Notes**

- When used as digital input, a series 33 k $\Omega$  resistor must be used to protect against automotive transients.
- Reverse battery protection series diodes must be used externally to protect the internal circuitry.
- This pin can be connected directly to the battery line for voltage measurements. The pin is self protected against reverse battery connections. It is strongly recommended to connect a 10 k $\Omega$  resistor in series with this pin for protection purposes.
- External capacitor (1.0  $\mu$ F < C < 10  $\mu$ F; 0.1  $\Omega$  < ESR < 5.0  $\Omega$ ) required.
- External capacitor (2.0  $\mu$ F < C < 100  $\mu$ F; 0.1  $\Omega$  < ESR < 10  $\Omega$ ) required.

## ELECTRICAL CHARACTERISTICS

## MAXIMUM RATINGS

Table 3. Maximum Ratings

All voltages are with respect to ground unless otherwise noted. Exceeding these ratings may cause a malfunction or permanent damage to the device.

Ratings	Symbol	Value	Unit
<b>ELECTRICAL RATINGS</b>			
Supply Voltage at VS1 and VS2			V
Normal Operation (DC)	$V_{SUP(SS)}$	-0.3 to 27	
Transient Conditions (load dump)	$V_{SUP(PK)}$	-0.3 to 40	
Supply Voltage at VDD	$V_{DD}$	-0.3 to 5.5	V
Input / Output Pins Voltage <sup>(6)</sup>			V
$\overline{CS}$ , $\overline{RST}$ , SCLK, PwMIN, ADOUT0, ADOUT1, MOSI, MISO, TXD, RXD, HVDD	$V_{IN}$	-0.3 to $V_{DD} + 0.3$	
Interrupt Pin ( $\overline{IRQ}$ ) <sup>(7)</sup>	$V_{IN(IRQ)}$	-0.3 to 11	
HS1 and HS2 Pin Voltage (DC)	$V_{HS}$	-0.3 to $V_{SUP} + 0.3$	V
LS1 and LS2 Pin Voltage (DC)	$V_{LS}$	-0.3 to 45	V
L1, L2, L3 and L4 Pin Voltage			V
Normal Operation with a series 33 k resistor (DC)	$V_{LxDC}$	-18 to 40	
Transient input voltage with external component (according to ISO7637-2) (See <a href="#">Figure 5</a> , page 20)	$V_{LxTR}$	±100	
ISENSEH and ISENSEL Pin Voltage (DC)	$V_{ISENSE}$	-0.3 to 40	V
VSENSE Pin Voltage (DC)	$V_{VSENSE}$	-27 to 40	V
LIN Pin Voltage			V
Normal Operation (DC)	$V_{BUSDC}$	-18 to 40	
Transient input voltage with external component (according to ISO7637-2) (See <a href="#">Figure 4</a> , page 20)	$V_{BUSTR}$	-150 to 100	
VDD output current	$I_{VDD}$	Internally Limited	A

## Notes

6. Exceeding voltage limits on specified pins may cause a malfunction or permanent damage to the device.
7. Extended voltage range for programming purpose only.

ELECTRICAL CHARACTERISTICS  
MAXIMUM RATINGS**Table 3. Maximum Ratings (continued)**

All voltages are with respect to ground unless otherwise noted. Exceeding these ratings may cause a malfunction or permanent damage to the device.

Ratings	Symbol	Value	Unit
ESD Capability			V
AECQ100			
Human Body Model - JESD22/A114 ( $C_{ZAP} = 100 \text{ pF}$ , $R_{ZAP} = 1500 \Omega$ )			
LIN Pin	$V_{ESD1-1}$	$\pm 8.0k$	
L1, L2, L3, and L4	$V_{ESD1-2}$	$\pm 6.0k$	
all other Pins	$V_{ESD1-3}$	$\pm 2000$	
Charge Device Model - JESD22/C101 ( $C_{ZAP} = 4.0 \text{ pF}$ )			
Corner Pins (Pins 1, 8, 9, 16, 17, 24, 25 and 32)	$V_{ESD2-1}$	$\pm 750$	
All other Pins (Pins 2-7, 10-15, 18-23, 26-31)	$V_{ESD2-2}$	$\pm 500$	
According to LIN Conformance Test Specification / LIN EMC Test Specification, August 2004 ( $C_{ZAP} = 150 \text{ pF}$ , $R_{ZAP} = 330 \Omega$ )			
Contact Discharge, Unpowered			
LIN pin with 220 pF	$V_{ESD3-1}$	$\pm 20k$	
LIN pin without capacitor	$V_{ESD3-2}$	$\pm 11k$	
VS1/VS2 (100 nF to ground)	$V_{ESD3-3}$	$> \pm 12k$	
Lx inputs (33 k $\Omega$ serial resistor)	$V_{ESD3-4}$	$\pm 6000$	
According to IEC 61000-4-2 ( $C_{ZAP} = 150 \text{ pF}$ , $R_{ZAP} = 330 \Omega$ )			
Unpowered			
LIN pin with 220 pF and without capacitor	$V_{ESD4-1}$	$\pm 8000$	
VS1/VS2 (100 nF to ground)	$V_{ESD4-2}$	$\pm 8000$	
Lx inputs (33 k $\Omega$ serial resistor)	$V_{ESD4-3}$	$\pm 8000$	

**THERMAL RATINGS**

Operating Ambient Temperature <sup>(8)</sup>	$T_A$		$^{\circ}\text{C}$
33912		-40 to 125	
34912		-40 to 85	
Operating Junction Temperature	$T_J$	-40 to 150	$^{\circ}\text{C}$
Storage Temperature	$T_{STG}$	-55 to 150	$^{\circ}\text{C}$
Thermal Resistance, Junction to Ambient	$R_{\theta JA}$		$^{\circ}\text{C}/\text{W}$
Natural Convection, Single Layer board (1s) <sup>(8), (9)</sup>		85	
Natural Convection, Four Layer board (2s2p) <sup>(8), (10)</sup>		56	
Thermal Resistance, Junction to Case <sup>(11)</sup>	$R_{\theta JC}$	23	$^{\circ}\text{C}/\text{W}$
Peak Package Reflow Temperature During Reflow <sup>(12), (13)</sup>	$T_{PPRT}$	Note 13	$^{\circ}\text{C}$

## Notes

- Junction temperature is a function of on-chip power dissipation, package thermal resistance, mounting site (board) temperature, ambient temperature, air flow, power dissipation of other components on the board, and board thermal resistance.
- Per JEDEC JESD51-2 with the single layer board (JESD51-3) horizontal.
- Per JEDEC JESD51-6 with the board (JESD51-7) horizontal.
- Thermal resistance between the die and the case top surface as measured by the cold plate method (MIL SPEC-883 Method 1012.1).
- Pin soldering temperature limit is for 10 seconds maximum duration. Not designed for immersion soldering. Exceeding these limits may cause malfunction or permanent damage to the device.
- Freescale's Package Reflow capability meets Pb-free requirements for JEDEC standard J-STD-020C. For Peak Package Reflow Temperature and Moisture Sensitivity Levels (MSL), go to [www.freescale.com](http://www.freescale.com), search by part number [e.g. remove prefixes/suffixes and enter the core ID to view all orderable parts. (i.e. MC33xxx enter 33xxx), and review parametrics.



## STATIC ELECTRICAL CHARACTERISTICS

**Table 4. Static Electrical Characteristics**

Characteristics noted under conditions  $5.5\text{ V} \leq V_{\text{SUP}} \leq 18\text{ V}$ ,  $-40^\circ\text{C} \leq T_A \leq 125^\circ\text{C}$  for the 33912 and  $-40^\circ\text{C} \leq T_A \leq 85^\circ\text{C}$  for the 34912, unless otherwise noted. Typical values noted reflect the approximate parameter mean at  $T_A = 25^\circ\text{C}$  under nominal conditions, unless otherwise noted.

Characteristic	Symbol	Min	Typ	Max	Unit
<b>SUPPLY VOLTAGE RANGE (VS1, VS2)</b>					
Nominal Operating Voltage	$V_{\text{SUP}}$	5.5	–	18	V
Functional Operating Voltage <sup>(14)</sup>	$V_{\text{SUPOP}}$	–	–	27	V
Load Dump	$V_{\text{SUPLD}}$	–	–	40	V
<b>SUPPLY CURRENT RANGE (<math>V_{\text{SUP}} = 13.5\text{ V}</math>)</b>					
Normal Mode ( $I_{\text{OUT}}$ at $V_{\text{DD}} = 10\text{ mA}$ ), LIN Recessive State <sup>(15)</sup>	$I_{\text{RUN}}$	–	4.5	10	mA
Stop Mode, VDD ON with $I_{\text{OUT}} = 100\text{ }\mu\text{A}$ , LIN Recessive State <sup>(15), (16), (17), (18)</sup>	$I_{\text{STOP}}$				$\mu\text{A}$
5.5 V < $V_{\text{SUP}} < 12\text{ V}$		–	47	80	
$V_{\text{SUP}} = 13.5\text{ V}$		–	62	90	
$13.5\text{ V} < V_{\text{SUP}} < 18\text{ V}$		–	180	400	
Sleep Mode, VDD OFF, LIN Recessive State <sup>(15), (17)</sup>	$I_{\text{SLEEP}}$				$\mu\text{A}$
5.5 V < $V_{\text{SUP}} < 12\text{ V}$		–	27	35	
$V_{\text{SUP}} = 13.5\text{ V}$		–	33	48	
$13.5\text{ V} \leq V_{\text{SUP}} < 18\text{ V}$		–	160	300	
Cyclic Sense Supply Current Adder <sup>(19)</sup>	$I_{\text{CYCLIC}}$	–	10	–	$\mu\text{A}$
<b>SUPPLY UNDER/OVER-VOLTAGE DETECTIONS</b>					
Power-On Reset (BATFAIL) <sup>(20)</sup>					V
Threshold (measured on VS1) <sup>(19)</sup>	$V_{\text{BATFAIL}}$	1.5	3.0	3.9	
Hysteresis (measured on VS1) <sup>(19)</sup>	$V_{\text{BATFAIL\_HYS}}$	–	0.9	–	
$V_{\text{SUP}}$ under-voltage detection (VSUV Flag) (Normal and Normal Request Modes, Interrupt Generated)					V
Threshold (measured on VS1)	$V_{\text{SUV}}$	5.55	6.0	6.6	
Hysteresis (measured on VS1)	$V_{\text{SUV\_HYS}}$	–	0.2	–	
$V_{\text{SUP}}$ over-voltage detection (VSOV Flag) (Normal and Normal Request Modes, Interrupt Generated)					V
Threshold (measured on VS1)	$V_{\text{SOV}}$	18	19.25	20.5	
Hysteresis (measured on VS1)	$V_{\text{SOV\_HYS}}$	–	1.0	–	

## Notes

- Device is fully functional. All features are operating.
- Total current ( $I_{\text{VS1}} + I_{\text{VS2}}$ ) measured at GND pins excluding all loads, cyclic sense disabled.
- Total  $I_{\text{DD}}$  current (including loads) below  $100\text{ }\mu\text{A}$ .
- Stop and Sleep Modes current will increase if  $V_{\text{SUP}}$  exceeds  $13.5\text{ V}$ .
- This parameter is guaranteed after  $90\text{ ms}$ .
- This parameter is guaranteed by process monitoring but not production tested.
- The Flag is set during power up sequence. To clear the flag, a SPI read must be performed.

ELECTRICAL CHARACTERISTICS  
STATIC ELECTRICAL CHARACTERISTICS**Table 4. Static Electrical Characteristics (continued)**

Characteristics noted under conditions  $5.5\text{ V} \leq V_{\text{SUP}} \leq 18\text{ V}$ ,  $-40^\circ\text{C} \leq T_A \leq 125^\circ\text{C}$  for the 33912 and  $-40^\circ\text{C} \leq T_A \leq 85^\circ\text{C}$  for the 34912, unless otherwise noted. Typical values noted reflect the approximate parameter mean at  $T_A = 25^\circ\text{C}$  under nominal conditions, unless otherwise noted.

Characteristic	Symbol	Min	Typ	Max	Unit
<b>VOLTAGE REGULATOR<sup>(21)</sup> (VDD)</b>					
Normal Mode Output Voltage $1.0\text{ mA} < I_{\text{VDD}} < 50\text{ mA}$ ; $5.5\text{ V} < V_{\text{SUP}} < 27\text{ V}$	$V_{\text{DDRUN}}$	4.75	5.00	5.25	V
Normal Mode Output Current Limitation	$I_{\text{VDDRUN}}$	60	110	200	mA
Dropout Voltage <sup>(22)</sup> $I_{\text{VDD}} = 50\text{ mA}$	$V_{\text{DDDROP}}$	–	0.1	0.25	V
Stop Mode Output Voltage $I_{\text{VDD}} < 5.0\text{ mA}$	$V_{\text{DDSTOP}}$	4.75	5.0	5.25	V
Stop Mode Output Current Limitation	$I_{\text{VDDSTOP}}$	6.0	13	36	mA
Line Regulation Normal Mode, $5.5\text{ V} < V_{\text{SUP}} < 18\text{ V}$ ; $I_{\text{VDD}} = 10\text{ mA}$ Stop Mode, $5.5\text{ V} < V_{\text{SUP}} < 18\text{ V}$ ; $I_{\text{VDD}} = 1.0\text{ mA}$	$LR_{\text{RUN}}$ $LR_{\text{STOP}}$	–	–	25	mV
Load Regulation Normal Mode, $1.0\text{ mA} < I_{\text{VDD}} < 50\text{ mA}$ Stop Mode, $0.1\text{ mA} < I_{\text{VDD}} < 5.0\text{ mA}$	$LD_{\text{RUN}}$ $LD_{\text{STOP}}$	–	–	80	mV
Over-temperature Prewarning (Junction) <sup>(23)</sup> Interrupt generated, VDDOT Bit Set	$T_{\text{PRE}}$	90	115	140	$^\circ\text{C}$
Over-temperature Prewarning Hysteresis <sup>(23)</sup>	$T_{\text{PRE\_HYS}}$	–	13	–	$^\circ\text{C}$
Over-temperature Shutdown Temperature (Junction) <sup>(23)</sup>	$T_{\text{SD}}$	150	170	190	$^\circ\text{C}$
Over-temperature Shutdown Hysteresis <sup>(23)</sup>	$T_{\text{SD\_HYS}}$	–	13	–	$^\circ\text{C}$
<b>HALL SENSOR SUPPLY OUTPUT<sup>(24)</sup> (HVDD)</b>					
$V_{\text{DD}}$ Voltage matching $H_{\text{VDDACC}} = (HVDD - VDD) / VDD * 100\%$ $I_{\text{HVDD}} = 15\text{ mA}$	$H_{\text{VDDACC}}$	-2.0	–	2.0	%
Current Limitation	$I_{\text{HVDD}}$	20	35	50	mA
Dropout Voltage $I_{\text{HVDD}} = 15\text{ mA}$ ; $I_{\text{VDD}} = 5.0\text{ mA}$	$H_{\text{VDDDROP}}$	–	160	300	mV
Line Regulation $I_{\text{HVDD}} = 5.0\text{ mA}$ ; $I_{\text{VDD}} = 5.0\text{ mA}$	$LR_{\text{HVDD}}$	–	–	40	mV
Load Regulation $1.0\text{ mA} > I_{\text{HVDD}} > 15\text{ mA}$ ; $I_{\text{VDD}} = 5.0\text{ mA}$	$LD_{\text{HVDD}}$	–	–	20	mV

## Notes

- Specification with external capacitor  $2.0\text{ }\mu\text{F} < C < 100\text{ }\mu\text{F}$  and  $100\text{ m}\Omega \leq \text{ESR} \leq 10\text{ }\Omega$ .
- Measured when voltage has dropped 250 mV below its nominal Value (5.0 V).
- This parameter is guaranteed by process monitoring but not production tested.
- Specification with external capacitor  $1.0\text{ }\mu\text{F} < C < 10\text{ }\mu\text{F}$  and  $100\text{ m}\Omega \leq \text{ESR} \leq 10\text{ }\Omega$ .

**Table 4. Static Electrical Characteristics (continued)**

Characteristics noted under conditions  $5.5\text{ V} \leq V_{\text{SUP}} \leq 18\text{ V}$ ,  $-40^\circ\text{C} \leq T_A \leq 125^\circ\text{C}$  for the 33912 and  $-40^\circ\text{C} \leq T_A \leq 85^\circ\text{C}$  for the 34912, unless otherwise noted. Typical values noted reflect the approximate parameter mean at  $T_A = 25^\circ\text{C}$  under nominal conditions, unless otherwise noted.

Characteristic	Symbol	Min	Typ	Max	Unit
<b>RST INPUT/OUTPUT PIN (RST)</b>					
VDD Low Voltage Reset Threshold	$V_{\text{RSTTH}}$	4.3	4.5	4.7	V
Low-state Output Voltage $I_{\text{OUT}} = 1.5\text{ mA}$ ; $3.5\text{ V} \leq V_{\text{SUP}} \leq 27\text{ V}$	$V_{\text{OL}}$	0.0	–	0.9	V
High-state Output Current ( $0\text{ V} < V_{\text{OUT}} < 3.5\text{ V}$ )	$I_{\text{OH}}$	-150	-250	-350	$\mu\text{A}$
Pull-down Current Limitation (internally limited) $V_{\text{OUT}} = V_{\text{DD}}$	$I_{\text{PD\_MAX}}$	1.5	–	8.0	mA
Low-state Input Voltage	$V_{\text{IL}}$	-0.3	–	$0.3 \times V_{\text{DD}}$	V
High-state Input Voltage	$V_{\text{IH}}$	$0.7 \times V_{\text{DD}}$	–	$V_{\text{DD}} + 0.3$	V
<b>MISO SPI OUTPUT PIN (MISO)</b>					
Low-state Output Voltage $I_{\text{OUT}} = 1.5\text{ mA}$	$V_{\text{OL}}$	0.0	–	1.0	V
High-state Output Voltage $I_{\text{OUT}} = -250\text{ }\mu\text{A}$	$V_{\text{OH}}$	$V_{\text{DD}} - 0.9$	–	$V_{\text{DD}}$	V
Tri-state Leakage Current $0\text{ V} \leq V_{\text{MISO}} \leq V_{\text{DD}}$	$I_{\text{TRIMISO}}$	-10	–	10	$\mu\text{A}$
<b>SPI INPUT PINS (MOSI, SCLK, <math>\overline{\text{CS}}</math>)</b>					
Low-state Input Voltage	$V_{\text{IL}}$	-0.3	–	$0.3 \times V_{\text{DD}}$	V
High-state Input Voltage	$V_{\text{IH}}$	$0.7 \times V_{\text{DD}}$	–	$V_{\text{DD}} + 0.3$	V
MOSI, SCLK Input Current $0\text{ V} \leq V_{\text{IN}} \leq V_{\text{DD}}$	$I_{\text{IN}}$	-10	–	10	$\mu\text{A}$
$\overline{\text{CS}}$ Pull-up Current $0\text{ V} < V_{\text{IN}} < 3.5\text{ V}$	$I_{\text{PUCS}}$	10	20	30	$\mu\text{A}$
<b>INTERRUPT OUTPUT PIN (IRQ)</b>					
Low-state Output Voltage $I_{\text{OUT}} = 1.5\text{ mA}$	$V_{\text{OL}}$	0.0	–	0.8	V
High-state Output Voltage $I_{\text{OUT}} = -250\text{ }\mu\text{A}$	$V_{\text{OH}}$	$V_{\text{DD}} - 0.8$	–	$V_{\text{DD}}$	V
Leakage Current $V_{\text{DD}} \leq V_{\text{OUT}} \leq 10\text{ V}$	$I_{\text{OUT}}$	–	–	2.0	mA
<b>PULSE WIDTH MODULATION INPUT PIN (PWMIN)</b>					
Low-state Input Voltage	$V_{\text{IL}}$	-0.3	–	$0.3 \times V_{\text{DD}}$	V
High-state Input Voltage	$V_{\text{IH}}$	$0.7 \times V_{\text{DD}}$	–	$V_{\text{DD}} + 0.3$	V
Pull-up current $0\text{ V} < V_{\text{IN}} < 3.5\text{ V}$	$I_{\text{PUPWMIN}}$	10	20	30	$\mu\text{A}$

ELECTRICAL CHARACTERISTICS  
STATIC ELECTRICAL CHARACTERISTICS**Table 4. Static Electrical Characteristics (continued)**

Characteristics noted under conditions  $5.5\text{ V} \leq V_{\text{SUP}} \leq 18\text{ V}$ ,  $-40^\circ\text{C} \leq T_{\text{A}} \leq 125^\circ\text{C}$  for the 33912 and  $-40^\circ\text{C} \leq T_{\text{A}} \leq 85^\circ\text{C}$  for the 34912, unless otherwise noted. Typical values noted reflect the approximate parameter mean at  $T_{\text{A}} = 25^\circ\text{C}$  under nominal conditions, unless otherwise noted.

Characteristic	Symbol	Min	Typ	Max	Unit
<b>HIGH SIDE OUTPUTS HS1 AND HS2 PINS (HS1, HS2)</b>					
Output Drain-to-Source On Resistance $T_{\text{J}} = 25^\circ\text{C}$ , $I_{\text{LOAD}} = 50\text{ mA}$ ; $V_{\text{SUP}} > 9.0\text{ V}$ $T_{\text{J}} = 150^\circ\text{C}$ , $I_{\text{LOAD}} = 50\text{ mA}$ ; $V_{\text{SUP}} > 9.0\text{ V}$ <sup>(25)</sup> $T_{\text{J}} = 150^\circ\text{C}$ , $I_{\text{LOAD}} = 30\text{ mA}$ ; $5.5\text{ V} < V_{\text{SUP}} < 9.0\text{ V}$ <sup>(25)</sup>	$R_{\text{DS(ON)}}$	–	–	7.0 10 14	$\Omega$
Output Current Limitation <sup>(26)</sup> $0\text{ V} < V_{\text{OUT}} < V_{\text{SUP}} - 2.0\text{ V}$	$I_{\text{LIMHSX}}$	60	90	250	mA
Open Load Current Detection <sup>(27)</sup>	$I_{\text{OLHSX}}$	–	5.0	7.5	mA
Leakage Current $-0.2\text{ V} < V_{\text{HSX}} < V_{\text{S2}} + 0.2\text{ V}$	$I_{\text{LEAK}}$	–	–	10	$\mu\text{A}$
Short-circuit Detection Threshold <sup>(28)</sup> $5.5\text{ V} < V_{\text{SUP}} < 27\text{ V}$	$V_{\text{THSC}}$	$V_{\text{SUP}} - 2.0$	–	–	V
Over-temperature Shutdown <sup>(29), (33)</sup>	$T_{\text{HSSD}}$	140	160	180	$^\circ\text{C}$
Over-temperature Shutdown Hysteresis <sup>(33)</sup>	$T_{\text{HSSD\_HYS}}$	–	10	–	$^\circ\text{C}$
<b>LOW SIDE OUTPUTS LS1 AND LS2 PINS (LS1, LS2)</b>					
Output Drain-to-Source On Resistance $T_{\text{J}} = 25^\circ\text{C}$ , $I_{\text{LOAD}} = 150\text{ mA}$ , $V_{\text{SUP}} > 9.0\text{ V}$ $T_{\text{J}} = 125^\circ\text{C}$ , $I_{\text{LOAD}} = 150\text{ mA}$ , $V_{\text{SUP}} > 9.0\text{ V}$ $T_{\text{J}} = 125^\circ\text{C}$ , $I_{\text{LOAD}} = 120\text{ mA}$ , $5.5\text{ V} < V_{\text{SUP}} < 9.0\text{ V}$	$R_{\text{DS(ON)}}$	–	–	2.5 4.5 10	$\Omega$
Output Current Limitation <sup>(30)</sup> $2.0\text{ V} < V_{\text{OUT}} < V_{\text{SUP}}$	$I_{\text{LIMLSX}}$	160	275	350	mA
Open Load Current Detection <sup>(31)</sup>	$I_{\text{OLLSX}}$	–	7.5	12	mA
Leakage Current $-0.2\text{ V} < V_{\text{OUT}} < V_{\text{S1}}$	$I_{\text{LEAK}}$	–	–	10	$\mu\text{A}$
Active Output Energy Clamp $I_{\text{OUT}} = 150\text{ mA}$	$V_{\text{CLAMP}}$	$V_{\text{SUP}} + 2.0$	–	$V_{\text{SUP}} + 5.0$	V
Short-circuit Detection Threshold <sup>(28)</sup> $5.5\text{ V} < V_{\text{SUP}} < 27\text{ V}$	$V_{\text{THSC}}$	2.0	–	–	V
Over-temperature Shutdown <sup>(32), (33)</sup>	$T_{\text{LSSD}}$	140	160	180	$^\circ\text{C}$
Over-temperature Shutdown Hysteresis <sup>(33)</sup>	$T_{\text{LSSD\_HYS}}$	–	10	–	$^\circ\text{C}$

## Notes

25. This parameter is production tested up to  $T_{\text{A}} = 125^\circ\text{C}$ , and guaranteed by process monitoring up to  $T_{\text{J}} = 150^\circ\text{C}$ .
26. When over-current occurs, the corresponding high side stays ON with limited current capability and the HSxCL flag is set in the HSSR.
27. When open load occurs, the flag (HSxOP) is set in the HSSR.
28. HS and LS automatically shutdown if HSOT or LSOT occurs or if the HVSE flag is enabled and an over-voltage occurs.
29. When over-temperature shutdown occurs, both high sides are turned off. All flags in HSSR are set.
30. When over-current occurs, the corresponding low side stays ON with limited current capability and the LSxCL flag is set in the LSSR.
31. When open load occurs, the flag (LSxOP) is set in the LSSR.
32. When over-temperature shutdown occurs, both low sides are turned off. All flags in LSSR are set.
33. Guaranteed by characterization but not production tested

**Table 4. Static Electrical Characteristics (continued)**

Characteristics noted under conditions  $5.5\text{ V} \leq V_{\text{SUP}} \leq 18\text{ V}$ ,  $-40^\circ\text{C} \leq T_{\text{A}} \leq 125^\circ\text{C}$  for the 33912 and  $-40^\circ\text{C} \leq T_{\text{A}} \leq 85^\circ\text{C}$  for the 34912, unless otherwise noted. Typical values noted reflect the approximate parameter mean at  $T_{\text{A}} = 25^\circ\text{C}$  under nominal conditions, unless otherwise noted.

Characteristic	Symbol	Min	Typ	Max	Unit
<b>L1, L2, L3 AND L4 INPUT PINS (L1, L2, L3, L4)</b>					
Low Detection Threshold <sup>(34)</sup> $5.5\text{ V} < V_{\text{SUP}} < 27\text{ V}$	$V_{\text{THL}}$	2.0	2.5	3.0	V
High Detection Threshold <sup>(34)</sup> $5.5\text{ V} < V_{\text{SUP}} < 27\text{ V}$	$V_{\text{THH}}$	3.0	3.5	4.0	V
Hysteresis <sup>(34)</sup> $5.5\text{ V} < V_{\text{SUP}} < 27\text{ V}$	$V_{\text{HYS}}$	0.4	0.8	1.4	V
Input Current <sup>(35)</sup> $-0.2\text{ V} < V_{\text{IN}} < V_{\text{S1}}$	$I_{\text{IN}}$	-10	–	10	$\mu\text{A}$
Analog Input Impedance <sup>(36)</sup>	$R_{\text{LXIN}}$	800	1300	2000	$\text{k}\Omega$
Analog Input Divider Ratio ( $\text{RATIO}_{\text{LX}} = V_{\text{Lx}} / V_{\text{ADOUT0}}$ ) LXDS (Lx Divider Select) = 0 LXDS (Lx Divider Select) = 1	$\text{RATIO}_{\text{LX}}$	0.95 3.42	1.0 3.6	1.05 3.78	
Analog Output offset Ratio LXDS (Lx Divider Select) = 0 LXDS (Lx Divider Select) = 1	$V_{\text{RATIO}_{\text{LX}}}$ - OFFSET	-80 -22	6.0 2.0	80 22	mV
Analog Inputs Matching LXDS (Lx Divider Select) = 0 LXDS (Lx Divider Select) = 1	$\text{LX}_{\text{MATCHING}}$	96 96	100 100	104 104	%

**WINDOW WATCHDOG CONFIGURATION PIN (WDCONF)<sup>(37)</sup>**

External Resistor Range	$R_{\text{EXT}}$	20	–	200	$\text{k}\Omega$
Watchdog Period Accuracy with External Resistor (Excluding Resistor Accuracy) <sup>(38)</sup>	$\text{WD}_{\text{ACC}}$	-15	–	15	%

**ANALOG MULTIPLEXER**

Temperature Sense Analog Output Voltage $T_{\text{A}} = -40^\circ\text{C}$ $T_{\text{A}} = 25^\circ\text{C}$ $T_{\text{A}} = 125^\circ\text{C}$	$V_{\text{ADOUT0\_TEMP}}$	2.0 2.8 3.6	- 3.0 -	2.8 3.6 4.6	V
Temperature Sense Analog Output Voltage per characterization <sup>(39)</sup> $T_{\text{A}} = 25^\circ\text{C}$	$V_{\text{ADOUT0\_25}}$	3.1	3.15	3.2	V
Internal Chip Temperature Sense Gain	$S_{\text{TTOV}}$	9.0	10.5	12	mV/K
Internal Chip Temperature Sense Gain per characterization at 3 temperatures <sup>(39)</sup> See <a href="#">Figure 16. Temperature Sense Gain</a>	$S_{\text{TTOV\_3T}}$	9.9	10.2	10.5	mV/K
VSENSE Input Divider Ratio ( $\text{RATIO}_{\text{VSENSE}} = V_{\text{VSENSE}} / V_{\text{ADOUT0}}$ ) $5.5\text{ V} < V_{\text{SUP}} < 27\text{ V}$	$\text{RATIO}_{\text{VSENSE}}$	5.0	5.25	5.5	

**Notes**

34. The unused Lx pins must be connected to ground.
35. Analog multiplexer input disconnected from Lx input pin.
36. Analog multiplexer input connected to Lx input pin.
37. For  $V_{\text{SUP}}$  4.7 V to 18 V
38. Watchdog timing period calculation formula:  $t_{\text{PWD}} [\text{ms}] = [0.466 * (R_{\text{EXT}} - 20)] + 10$  with ( $R_{\text{EXT}}$  in  $\text{k}\Omega$ )
39. These limits have been defined after laboratory characterization on 3 lots and 30 samples. These tighten limits could not be guaranteed by production test.

ELECTRICAL CHARACTERISTICS  
STATIC ELECTRICAL CHARACTERISTICS**Table 4. Static Electrical Characteristics (continued)**

Characteristics noted under conditions  $5.5\text{ V} \leq V_{\text{SUP}} \leq 18\text{ V}$ ,  $-40^\circ\text{C} \leq T_A \leq 125^\circ\text{C}$  for the 33912 and  $-40^\circ\text{C} \leq T_A \leq 85^\circ\text{C}$  for the 34912, unless otherwise noted. Typical values noted reflect the approximate parameter mean at  $T_A = 25^\circ\text{C}$  under nominal conditions, unless otherwise noted.

Characteristic	Symbol	Min	Typ	Max	Unit
VSENSE Input Divider Ratio ( $\text{RATIO}_{\text{VSENSE}} = V_{\text{SENSE}}/V_{\text{ADOUT0}}$ ) per characterization <sup>(40)</sup> $5.5 < V_{\text{SUP}} < 27\text{ V}$	$\text{RATIO}_{\text{VSENSE}}/Z$	5.15	5.25	5.35	
VSENSE Output Related Offset	$\text{OFFSET}_{\text{VSENSE}}$	-30	-10	30	mV
$V_{\text{SENSE}}$ Output Related Offset per characterization <sup>(40)</sup>	$\text{OFFSET}_{\text{VSENSE}}/_{\text{CZ}}$	-30	-12.6	0	mV

**ANALOG OUTPUTS (ADOUT0 AND ADOUT1)**

Maximum Output Voltage $-5.0\text{ mA} < I_O < 5.0\text{ mA}$	$V_{\text{OUT\_MAX}}$	$V_{\text{DD}} - 0.35$	-	$V_{\text{DD}}$	V
Minimum Output Voltage $-5.0\text{ mA} < I_O < 5.0\text{ mA}$	$V_{\text{OUT\_MIN}}$	0.0	-	0.35	V

**CURRENT SENSE AMPLIFIER (ISENSEH, ISENSEL)**

Gain CSGS (Current Sense Gain Select) = 0 CSGS (Current Sense Gain Select) = 1	G	29 14	30 14.5	31 15	
Differential Input Impedance CSGS (Current Sense Gain Select) = 0 CSGS (Current Sense Gain Select) = 1	DIFF	2.0 5.0	10 20	30 50	k $\Omega$
Common Mode Input Impedance CSGS (Current Sense Gain Select) = 0 CSGS (Current Sense Gain Select) = 1	CM	100 100	- -	200 200	k $\Omega$
ISENSEH, ISENSEL Input Voltage Range	$V_{\text{IN}}$	-0.2	-	3.0	V
Input Offset Voltage CSAZ (Current Sense Auto Zero) = 0 CSAZ (Current Sense Auto Zero) = 1	$V_{\text{IN\_OFFSET}}$	-15 -2.0	- -	15 2.0	mV

**RXD OUTPUT PIN (LIN PHYSICAL LAYER) (RXD)**

Low-state Output Voltage $I_{\text{OUT}} = 1.5\text{ mA}$	$V_{\text{OL}}$	0.0	-	0.8	V
High-state Output Voltage $I_{\text{OUT}} = -250\text{ }\mu\text{A}$	$V_{\text{OH}}$	$V_{\text{DD}} - 0.8$	-	$V_{\text{DD}}$	V

**TXD INPUT PIN (LIN PHYSICAL LAYER) (TXD)**

Low-state Input Voltage	$V_{\text{IL}}$	-0.3	-	$0.3 \times V_{\text{DD}}$	V
High-state Input Voltage	$V_{\text{IH}}$	$0.7 \times V_{\text{DD}}$	-	$V_{\text{DD}} + 0.3$	V
Pin Pull-up Current, $0\text{ V} < V_{\text{IN}} < 3.5\text{ V}$	$I_{\text{PUIN}}$	10	20	30	$\mu\text{A}$

**LIN PHYSICAL LAYER WITH J2602 FEATURE ENABLED (BIT DIS\_J2602 = 0)**

LIN Under-voltage threshold Positive and Negative threshold ( $V_{\text{THP}}$ , $V_{\text{THN}}$ )	$V_{\text{TH\_UNDER\_VOL}}/_{\text{TAGE}}$	5.0	-	6.0	V
Hysteresis ( $V_{\text{THP}} - V_{\text{THN}}$ )	$V_{\text{J2602\_DEG}}$	-	400	-	mV

## Notes

40. These limits have been defined after laboratory characterization on 3 lots and 30 samples. These tighten limits could not be guaranteed by production test.

**Table 4. Static Electrical Characteristics (continued)**

Characteristics noted under conditions  $5.5\text{ V} \leq V_{\text{SUP}} \leq 18\text{ V}$ ,  $-40^\circ\text{C} \leq T_{\text{A}} \leq 125^\circ\text{C}$  for the 33912 and  $-40^\circ\text{C} \leq T_{\text{A}} \leq 85^\circ\text{C}$  for the 34912, unless otherwise noted. Typical values noted reflect the approximate parameter mean at  $T_{\text{A}} = 25^\circ\text{C}$  under nominal conditions, unless otherwise noted.

Characteristic	Symbol	Min	Typ	Max	Unit
<b>LIN PHYSICAL LAYER, TRANSCEIVER (LIN)<sup>(41)</sup></b>					
Operating Voltage Range	$V_{\text{BAT}}$	8.0	-	18	V
Supply Voltage Range	$V_{\text{SUP}}$	7.0	-	18	V
Voltage Range within which the device is not destroyed	$V_{\text{SUP\_NON\_OP}}$	-0.3	-	40	V
Current Limitation for Driver Dominant State Driver ON, $V_{\text{BUS}} = 18\text{ V}$	$I_{\text{BUS\_LIM}}$	40	90	200	mA
Input Leakage Current at the receiver Driver off; $V_{\text{BUS}} = 0\text{ V}$ ; $V_{\text{BAT}} = 12\text{ V}$	$I_{\text{BUS\_PAS\_DOM}}$	-1.0	-	-	mA
Leakage Output Current to GND Driver Off; $8.0\text{ V} < V_{\text{BAT}} < 18\text{ V}$ ; $8.0\text{ V} < V_{\text{BUS}} < 18\text{ V}$ ; $V_{\text{BUS}} \geq V_{\text{BAT}}$	$I_{\text{BUS\_PAS\_REC}}$	-	-	20	$\mu\text{A}$
Control unit disconnected from ground <sup>(42)</sup> $\text{GND}_{\text{DEVICE}} = V_{\text{SUP}}$ ; $V_{\text{BAT}} = 12\text{ V}$ ; $0 < V_{\text{BUS}} < 18\text{ V}$	$I_{\text{BUS\_NO\_GND}}$	-1.0	-	1.0	mA
$V_{\text{BAT}}$ Disconnected; $V_{\text{SUP\_DEVICE}} = \text{GND}$ ; $0\text{ V} < V_{\text{BUS}} < 18\text{ V}$ <sup>(43)</sup>	$I_{\text{BUSNO\_BAT}}$	-	-	100	$\mu\text{A}$
Receiver Dominant State	$V_{\text{BUSDOM}}$	-	-	0.4	$V_{\text{SUP}}$
Receiver Recessive State	$V_{\text{BUSREC}}$	0.6	-	-	$V_{\text{SUP}}$
Receiver Threshold Center $(V_{\text{TH\_DOM}} + V_{\text{TH\_REC}})/2$	$V_{\text{BUS\_CNT}}$	0.475	0.5	0.525	$V_{\text{SUP}}$
Receiver Threshold Hysteresis $(V_{\text{TH\_REC}} - V_{\text{TH\_DOM}})$	$V_{\text{HYS}}$	-	-	0.175	$V_{\text{SUP}}$
Voltage Drop at the serial Diode in pull-up path	$V_{\text{SERDIODE}}$	0.4		1.0	V
$V_{\text{BAT\_SHIFT}}$	$V_{\text{SHIFT\_BAT}}$	0		11.5%	$V_{\text{BAT}}$
$\text{GND\_SHIFT}$	$V_{\text{SHIFT\_GND}}$	0		11.5%	$V_{\text{BAT}}$
LIN Wake-up threshold from Stop or Sleep mode <sup>(44)</sup>	$V_{\text{BUSWU}}$		5.3	5.8	V
LIN Pull-up Resistor to $V_{\text{SUP}}$	$R_{\text{SLAVE}}$	20	30	60	$\text{k}\Omega$
Over-temperature Shutdown <sup>(45)</sup>	$T_{\text{LINS D}}$	140	160	180	$^\circ\text{C}$
Over-temperature Shutdown Hysteresis	$T_{\text{LINS D\_HYS}}$	-	10	-	$^\circ\text{C}$

## Notes

41. Parameters guaranteed for  $7.0\text{ V} \leq V_{\text{SUP}} \leq 18\text{ V}$ .
42. Loss of local ground must not affect communication in the residual network.
43. Node has to sustain the current that can flow under this condition. Bus must remain operational under this condition.
44. This parameter is 100% tested on an Automatic Tester. However, since it has not been monitored during reliability stresses, Freescale does not guarantee this parameter during the product's life time.
45. When over-temperature shutdown occurs, the LIN bus goes in recessive state and the flag LINOT in LINSR is set.

## DYNAMIC ELECTRICAL CHARACTERISTICS

**Table 5. Dynamic Electrical Characteristics**

Characteristics noted under conditions  $5.5\text{ V} \leq V_{\text{SUP}} \leq 18\text{ V}$ ,  $-40^\circ\text{C} \leq T_A \leq 125^\circ\text{C}$  for the 33912 and  $-40^\circ\text{C} \leq T_A \leq 85^\circ\text{C}$  for the 34912, unless otherwise noted. Typical values noted reflect the approximate parameter mean at  $T_A = 25^\circ\text{C}$  under nominal conditions, unless otherwise noted.

Characteristic	Symbol	Min	Typ	Max	Unit
<b>SPI INTERFACE TIMING</b> (SEE <a href="#">Figure 13</a> , PAGE 23)					
SPI Operating Frequency	$f_{\text{SPIO P}}$	–	–	4.0	MHz
SCLK Clock Period	$t_{\text{P SCLK}}$	250	–	N/A	ns
SCLK Clock High Time <sup>(46)</sup>	$t_{\text{W SCLKH}}$	110	–	N/A	ns
SCLK Clock Low Time <sup>(46)</sup>	$t_{\text{W SCLKL}}$	110	–	N/A	ns
Falling Edge of $\overline{\text{CS}}$ to Rising Edge of SCLK <sup>(46)</sup>	$t_{\text{LEAD}}$	100	–	N/A	ns
Falling Edge of SCLK to $\overline{\text{CS}}$ Rising Edge <sup>(46)</sup>	$t_{\text{LAG}}$	100	–	N/A	ns
MOSI to Falling Edge of SCLK <sup>(46)</sup>	$t_{\text{SISU}}$	40	–	N/A	ns
Falling Edge of SCLK to MOSI <sup>(46)</sup>	$t_{\text{SIH}}$	40	–	N/A	ns
MISO Rise Time <sup>(46)</sup> $C_L = 220\text{ pF}$	$t_{\text{RSO}}$	–	40	–	ns
MISO Fall Time <sup>(46)</sup> $C_L = 220\text{ pF}$	$t_{\text{FSO}}$	–	40	–	ns
Time from Falling or Rising Edges of $\overline{\text{CS}}$ to: <sup>(46)</sup> - MISO Low-impedance - MISO High-impedance	$t_{\text{SOEN}}$ $t_{\text{SODIS}}$	0.0 0.0	– –	50 50	ns
Time from Rising Edge of SCLK to MISO Data Valid <sup>(46)</sup> $0.2 \times V_{\text{DD}} \leq \text{MISO} \leq 0.8 \times V_{\text{DD}}$ , $C_L = 100\text{ pF}$	$t_{\text{VALID}}$	0.0	–	75	ns

**RST OUTPUT PIN**

Reset Low-level Duration After $V_{\text{DD}}$ High (see <a href="#">Figure 12</a> , page 23)	$t_{\overline{\text{RST}}}$	0.65	1.0	1.35	ms
Reset Deglitch Filter Time	$t_{\overline{\text{RSTDF}}}$	350	480	900	ns

**WINDOW WATCHDOG CONFIGURATION PIN (WDCONF)**

Watchdog Time Period <sup>(47)</sup> External Resistor $R_{\text{EXT}} = 20\text{ k}\Omega$ (1%) External Resistor $R_{\text{EXT}} = 200\text{ k}\Omega$ (1%) Without External Resistor $R_{\text{EXT}}$ (WDCONF Pin Open)	$t_{\text{PWD}}$	8.5 79 110	10 94 150	11.5 108 205	ms
---	------------------	------------------	-----------------	--------------------	----

**CURRENT SENSE AMPLIFIER<sup>(46)</sup>**

Common Mode Rejection Ratio	CMR	70	–	–	dB
Supply Voltage Rejection Ratio <sup>(48)</sup>	SVR	60	–	–	dB
Gain Bandwidth Product	GBP	0.75	3.0	–	MHz
Output Slew-Rate	SR	0.5	–	–	V/ $\mu\text{s}$

## Notes

46. This parameter is guaranteed by process monitoring but not production tested.
47. Watchdog timing period calculation formula:  $t_{\text{PWD}} [\text{ms}] = [0.466 * (R_{\text{EXT}} - 20)] + 10$  with ( $R_{\text{EXT}}$  in  $\text{k}\Omega$ )
48. Analog Outputs are supplied by  $V_{\text{DD}}$  and from 100 Hz to 4.0 kHz



**Table 5. Dynamic Electrical Characteristics (continued)**

Characteristics noted under conditions  $5.5\text{ V} \leq V_{\text{SUP}} \leq 18\text{ V}$ ,  $-40^\circ\text{C} \leq T_A \leq 125^\circ\text{C}$  for the 33912 and  $-40^\circ\text{C} \leq T_A \leq 85^\circ\text{C}$  for the 34912, unless otherwise noted. Typical values noted reflect the approximate parameter mean at  $T_A = 25^\circ\text{C}$  under nominal conditions, unless otherwise noted.

Characteristic	Symbol	Min	Typ	Max	Unit
<b>L1, L2, L3 AND L4 INPUTS</b>					
Lx Filter Time Deglitcher <sup>(49)</sup>	$t_{\text{WUF}}$	8.0	20	38	$\mu\text{s}$
<b>STATE MACHINE TIMING</b>					
Delay Between $\overline{\text{CS}}$ LOW-to-HIGH Transition (at End of SPI Stop Command) and Stop Mode Activation <sup>(49)</sup>	$t_{\text{STOP}}$	–	–	5.0	$\mu\text{s}$
Normal Request Mode Timeout (see <a href="#">Figure 12</a> , page 23)	$t_{\text{NRTOUT}}$	110	150	205	ms
Cyclic Sense ON Time from Stop and Sleep mode <sup>(50)</sup>	$T_{\text{ON}}$	130	200	270	$\mu\text{s}$
Cyclic Sense Accuracy <sup>(49)</sup>		-35		+35	%
Delay Between SPI Command and HS/LS Turn On <sup>(51)</sup> $9.0\text{ V} < V_{\text{SUP}} < 27\text{ V}$	$t_{\text{S-ON}}$	–	–	10	$\mu\text{s}$
Delay Between SPI Command and HS/LS Turn Off <sup>(51)</sup> $9.0\text{ V} < V_{\text{SUP}} < 27\text{ V}$	$t_{\text{S-OFF}}$	–	–	10	$\mu\text{s}$
Delay Between Normal Request and Normal mode After a Watchdog Trigger Command (Normal Request Mode) <sup>(49)</sup>	$t_{\text{SNR2N}}$	–	–	10	$\mu\text{s}$
Delay Between $\overline{\text{CS}}$ Wake-up ( $\overline{\text{CS}}$ LOW to HIGH) in Stop mode and: Normal Request mode, VDD ON and $\overline{\text{RST}}$ HIGH First Accepted SPI Command	$t_{\text{WUCS}}$ $t_{\text{WUSPI}}$	9.0 90	15 —	80 N/A	$\mu\text{s}$
Minimum Time Between Rising and Falling Edge on the $\overline{\text{CS}}$	$t_{2\overline{\text{CS}}}$	4.0	—	—	$\mu\text{s}$
<b>J2602 DEGLITCHER</b>					
$V_{\text{SUP}}$ Deglitcher <sup>(52)</sup> (DIS_J2602 = 0)	$t_{\text{J2602\_DEG}}$	35	50	70	$\mu\text{s}$

**Notes**

49. This parameter is guaranteed by process monitoring but not production tested.
50. This parameter is 100% tested on an Automatic Tester. However, since it has not been monitored during reliability stresses, Freescale does not guarantee this parameter during the product's life time.
51. Delay between turn on or off command (rising edge on  $\overline{\text{CS}}$ ) and HS or LS ON or OFF, excluding rise or fall time due to external load.
52. This parameter has not been monitoring during operating life test.

ELECTRICAL CHARACTERISTICS  
**DYNAMIC ELECTRICAL CHARACTERISTICS**

**Table 5. Dynamic Electrical Characteristics (continued)**

Characteristics noted under conditions  $5.5\text{ V} \leq V_{\text{SUP}} \leq 18\text{ V}$ ,  $-40^\circ\text{C} \leq T_A \leq 125^\circ\text{C}$  for the 33912 and  $-40^\circ\text{C} \leq T_A \leq 85^\circ\text{C}$  for the 34912, unless otherwise noted. Typical values noted reflect the approximate parameter mean at  $T_A = 25^\circ\text{C}$  under nominal conditions, unless otherwise noted.

Characteristic	Symbol	Min	Typ	Max	Unit
<b>LIN PHYSICAL LAYER: DRIVER CHARACTERISTICS FOR NORMAL SLEW RATE - 20.0KBIT/SEC ACCORDING TO LIN PHYSICAL LAYER SPECIFICATION<sup>(53), (54)</sup></b>					
Duty Cycle 1: $TH_{\text{REC(MAX)}} = 0.744 * V_{\text{SUP}}$ $TH_{\text{DOM(MAX)}} = 0.581 * V_{\text{SUP}}$ $D1 = t_{\text{BUS\_REC(MIN)}} / (2 * t_{\text{BIT}})$ , $t_{\text{BIT}} = 50\ \mu\text{s}$ , $7.0\text{ V} \leq V_{\text{SUP}} \leq 18\text{ V}$	D1	0.396	—	—	
Duty Cycle 2: $TH_{\text{REC(MIN)}} = 0.422 * V_{\text{SUP}}$ $TH_{\text{DOM(MIN)}} = 0.284 * V_{\text{SUP}}$ $D2 = t_{\text{BUS\_REC(MAX)}} / (2 * t_{\text{BIT}})$ , $t_{\text{BIT}} = 50\ \mu\text{s}$ , $7.6\text{ V} \leq V_{\text{SUP}} \leq 18\text{ V}$	D2	—	—	0.581	
<b>LIN PHYSICAL LAYER: DRIVER CHARACTERISTICS FOR SLOW SLEW RATE - 10.4KBIT/SEC ACCORDING TO LIN PHYSICAL LAYER SPECIFICATION<sup>(53), (55)</sup></b>					
Duty Cycle 3: $TH_{\text{REC(MAX)}} = 0.778 * V_{\text{SUP}}$ $TH_{\text{DOM(MAX)}} = 0.616 * V_{\text{SUP}}$ $D3 = t_{\text{BUS\_REC(MIN)}} / (2 * t_{\text{BIT}})$ , $t_{\text{BIT}} = 96\ \mu\text{s}$ , $7.0\text{ V} \leq V_{\text{SUP}} \leq 18\text{ V}$	D3	0.417	—	—	
Duty Cycle 4: $TH_{\text{REC(MIN)}} = 0.389 * V_{\text{SUP}}$ $TH_{\text{DOM(MIN)}} = 0.251 * V_{\text{SUP}}$ $D4 = t_{\text{BUS\_REC(MAX)}} / (2 * t_{\text{BIT}})$ , $t_{\text{BIT}} = 96\ \mu\text{s}$ , $7.6\text{ V} \leq V_{\text{SUP}} \leq 18\text{ V}$	D4	—	—	0.590	

**Notes**

53. Bus load  $R_{\text{BUS}}$  and  $C_{\text{BUS}}$  1.0 nF / 1.0 k $\Omega$ , 6.8 nF / 660  $\Omega$ , 10 nF / 500  $\Omega$ . Measurement thresholds: 50% of TXD signal to LIN signal threshold defined at each parameter. See [Figure 6](#), page 21.
54. See [Figure 7](#), page 21.
55. See [Figure 8](#), page 21.

**Table 5. Dynamic Electrical Characteristics (continued)**

Characteristics noted under conditions  $5.5\text{ V} \leq V_{\text{SUP}} \leq 18\text{ V}$ ,  $-40^\circ\text{C} \leq T_{\text{A}} \leq 125^\circ\text{C}$  for the 33912 and  $-40^\circ\text{C} \leq T_{\text{A}} \leq 85^\circ\text{C}$  for the 34912, unless otherwise noted. Typical values noted reflect the approximate parameter mean at  $T_{\text{A}} = 25^\circ\text{C}$  under nominal conditions, unless otherwise noted.

Characteristic	Symbol	Min	Typ	Max	Unit
<b>LIN PHYSICAL LAYER: DRIVER CHARACTERISTICS FOR FAST SLEW RATE</b>					
LIN Fast Slew Rate (Programming mode)	SR <sub>FAST</sub>	—	20	—	V/ $\mu\text{s}$
<b>LIN PHYSICAL LAYER: CHARACTERISTICS AND WAKE-UP TIMINGS<sup>(56)</sup></b>					
Propagation Delay and Symmetry <sup>(57)</sup>					$\mu\text{s}$
Propagation Delay of Receiver, $t_{\text{REC\_PD}} = \text{MAX}(t_{\text{REC\_PDR}}, t_{\text{REC\_PDF}})$	$t_{\text{REC\_PD}}$	—	4.2	6.0	
Symmetry of Receiver Propagation Delay, $t_{\text{REC\_PDF}} - t_{\text{REC\_PDR}}$	$t_{\text{REC\_SYM}}$	-2.0	—	2.0	
Bus Wake-Up Deglitcher (Sleep and Stop modes) <sup>(58)(62) (59)</sup>	$t_{\text{PROPWL}}$	42	70	95	$\mu\text{s}$
Bus Wake-Up Event Reported					$\mu\text{s}$
From Sleep Mode <sup>(60)</sup>	$t_{\text{WAKE\_SLEEP}}$	—	—	1500	
From Stop Mode <sup>(61)</sup>	$t_{\text{WAKE\_STOP}}$	9.0	27	35	
TXD Permanent Dominant State Delay	$t_{\text{TXDDOM}}$	0.65	1.0	1.35	s
<b>PULSE WIDTH MODULATION INPUT PIN (PWMIN)</b>					
PWMIN pin <sup>(62)</sup>	$f_{\text{PWMIN}}$				kHz
Max. frequency to drive HS and LS output pins		-	10	-	

## Notes

56.  $V_{\text{SUP}}$  from 7.0 to 18 V, bus load  $R_{\text{BUS}}$  and  $C_{\text{BUS}}$  1.0 nF / 1.0 k $\Omega$ , 6.8 nF / 660  $\Omega$ , 10 nF / 500  $\Omega$ . Measurement thresholds: 50% of TXD signal to LIN signal threshold defined at each parameter. See [Figure 6](#), page 21.
57. See [Figure 9](#), page 22
58. See [Figure 10](#), page 22 for Sleep and [Figure 11](#), page 22 for Stop Mode.
59. This parameter is tested on automatic tester but has not been monitoring during operating life test.
60. The measurement is done with 1 $\mu\text{F}$  capacitor and 0mA current load on  $V_{\text{DD}}$ . The value takes into account the delay to charge the capacitor. The delay is measured between the bus wake-up threshold ( $V_{\text{BUSWU}}$ ) rising edge of the LIN bus and when  $V_{\text{DD}}$  reaches 3.0V. See [Figure 10](#), page 22. The delay depends of the load and capacitor on  $V_{\text{DD}}$ .
61. In Stop Mode, the delay is measured between the bus wake-up threshold ( $V_{\text{BUSWU}}$ ) and the falling edge of the  $\overline{\text{IRQ}}$  pin. See [Figure 11](#), page 22.
62. This parameter is guaranteed by process monitoring but not production tested.

**TIMING DIAGRAMS**

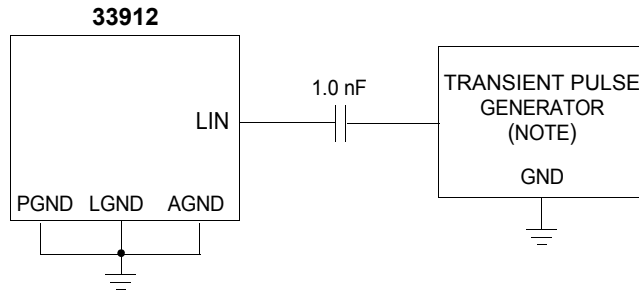

**Note** Waveform per ISO 7637-2. Test Pulses 1, 2, 3a, 3b.

**Figure 4. Test Circuit for Transient Test Pulses (LIN)**

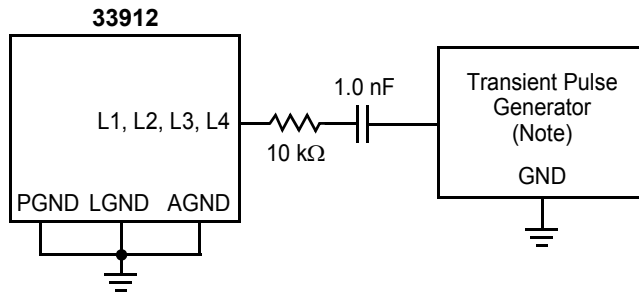

**Note** Waveform per ISO 7637-2. Test Pulses 1, 2, 3a, 3b,.

**Figure 5. Test Circuit for Transient Test Pulses (Lx)**

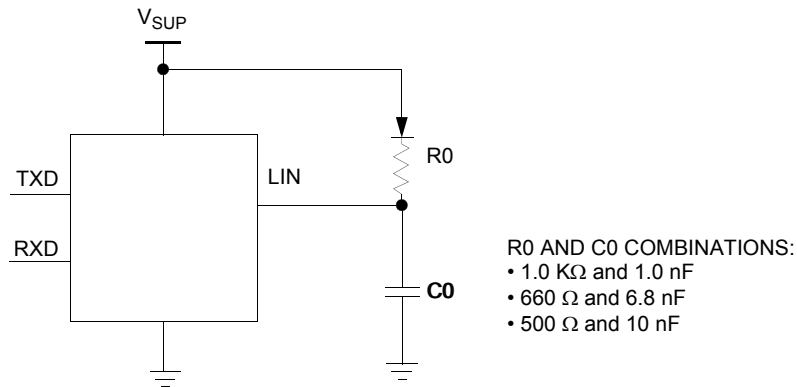

**Figure 6. Test Circuit for LIN Timing Measurements**

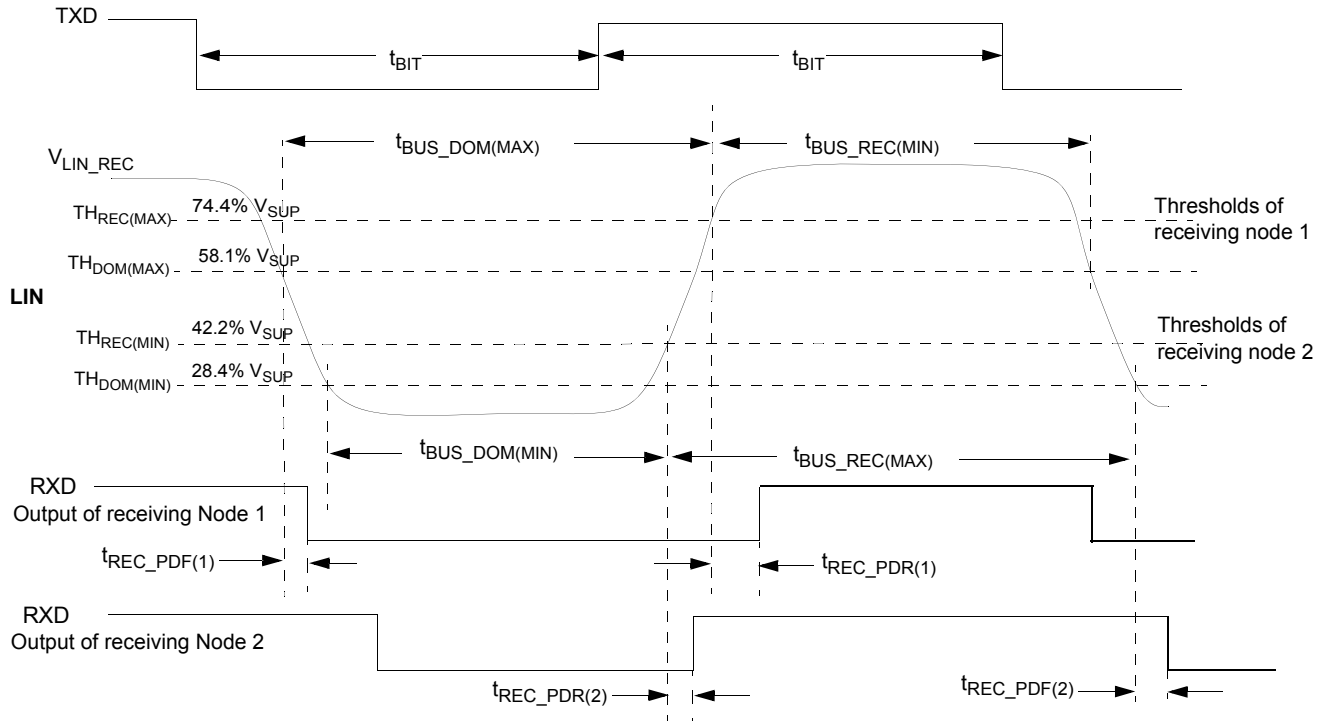

Figure 7. LIN Timing Measurements for Normal Slew Rate

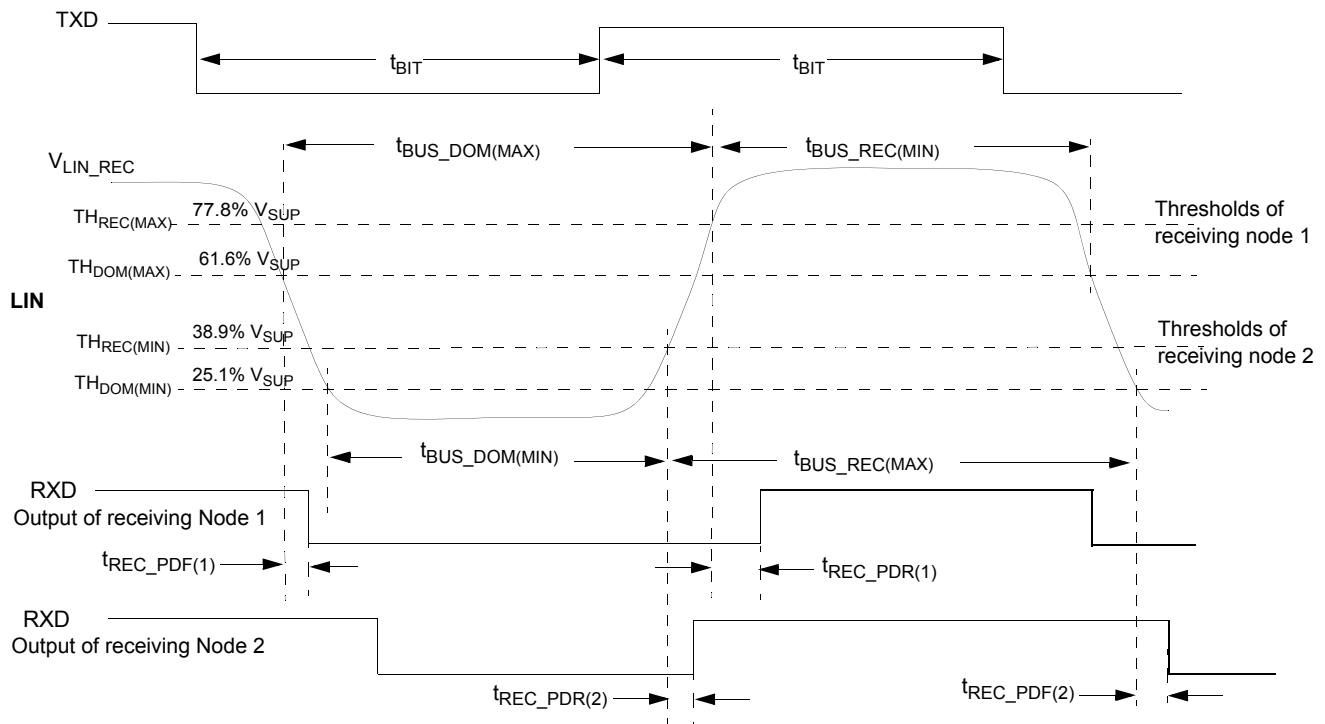

Figure 8. LIN Timing Measurements for Slow Slew Rate

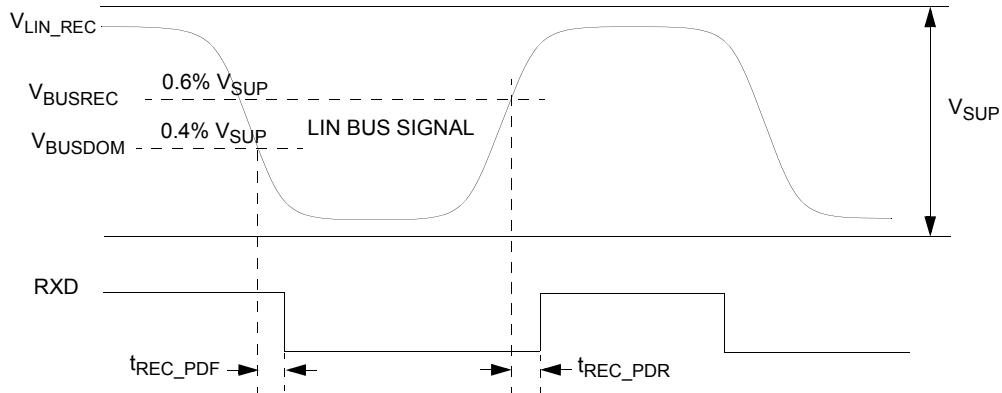

Figure 9. LIN Receiver Timing

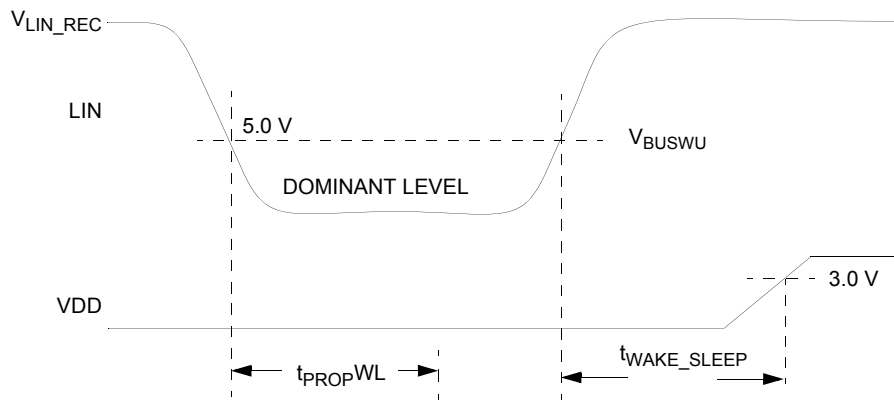

Figure 10. LIN Wake-Up Sleep Mode Timing

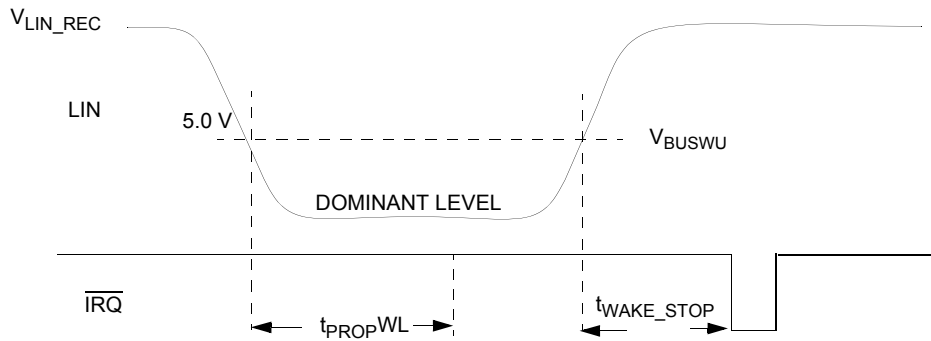

Figure 11. LIN Wake-up Stop Mode Timing

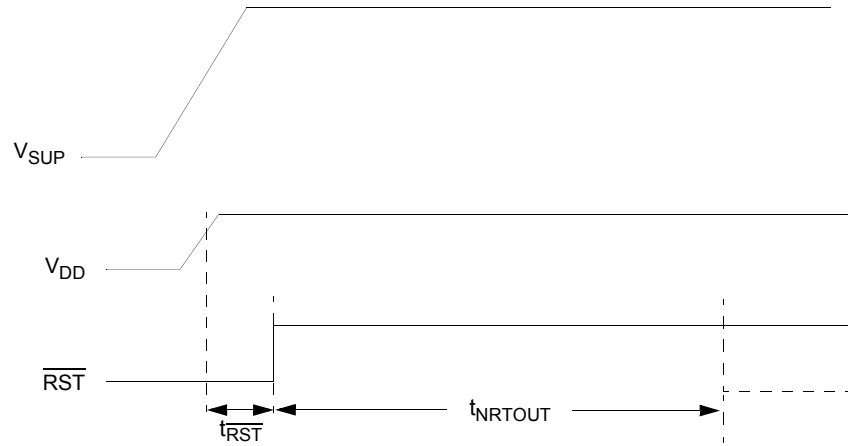

Figure 12. Power On Reset and Normal Request Timeout Timing

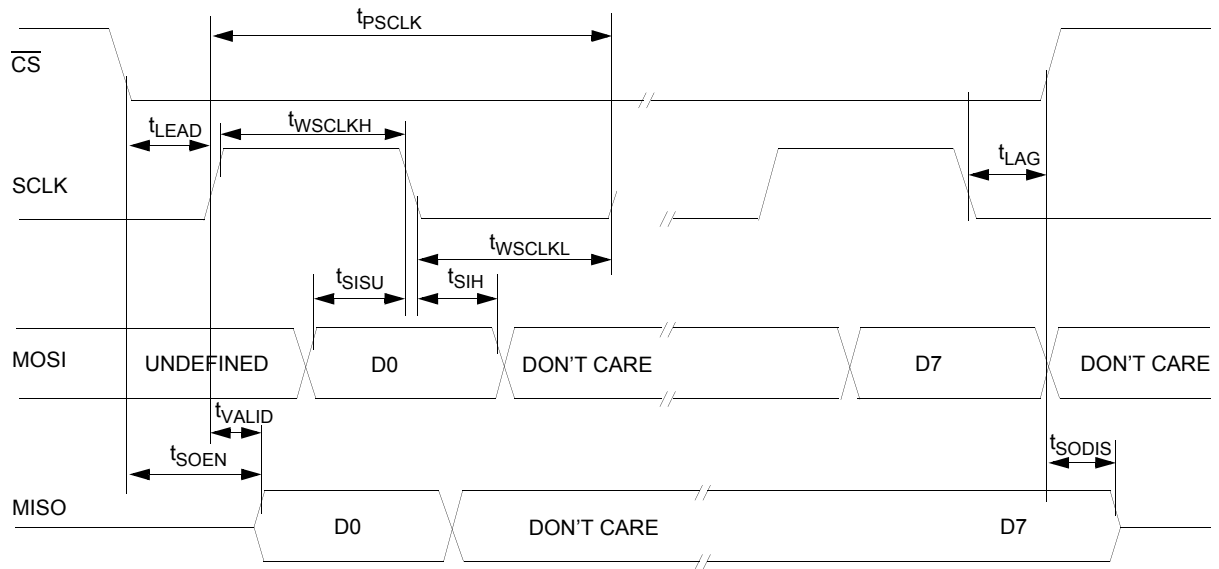

Figure 13. SPI Timing Characteristics

## FUNCTIONAL DESCRIPTION

### INTRODUCTION

The 33912 was designed and developed as a highly integrated and cost-effective solution for automotive and industrial applications. For automotive body electronics, the 33912 is well suited to perform relay control in applications such as a window lift, sunroof, etc. via the LIN bus.

Power switches are provided on the device configured as high side and low side outputs. Other ports are also provided,

which include a current and voltage sense port, a Hall Sensor port supply, and four wake-up capable pins. An internal voltage regulator provides power to a MCU device.

Also included in this device is a LIN physical layer, which communicates using a single wire. This enables this device to be compatible with 3-wire bus systems, where one wire is used for communication, one for battery, and one for ground.

### FUNCTIONAL PIN DESCRIPTION

See [Figure 1, 33912 Simplified Application Diagram](#), page 1, for a graphic representation of the various pins referred to in the following paragraphs. Also, see the pin diagram on page 5 for a description of the pin locations in the package.

#### RECEIVER OUTPUT PIN (RXD)

The RXD pin is a digital output. It is the receiver output of the LIN interface and reports the state of the bus voltage: RXD Low when LIN bus is dominant, RXD High when LIN bus is recessive.

#### TRANSMITTER INPUT PIN (TXD)

The TXD pin is a digital input. It is the transmitter input of the LIN interface and controls the state of the bus output (dominant when TXD is Low, recessive when TXD is High).

This pin has an internal pull-up to force recessive state in case the input is left floating.

#### LIN BUS PIN (LIN)

The LIN pin represents the single-wire bus transmitter and receiver. It is suited for automotive bus systems and is compliant to the LIN bus specification 2.0, 2.1, and SAE J2602-2.

The LIN interface is only active during Normal Mode. See [Table 6, Operating Modes Overview](#).

#### SERIAL DATA CLOCK PIN (SCLK)

The SCLK pin is the SPI clock input. MISO data changes on the positive transition of the SCLK. MOSI is sampled on the negative edge of the SCLK.

#### MASTER OUT SLAVE IN PIN (MOSI)

The MOSI digital pin receives SPI data from the MCU. This data input is sampled on the negative edge of SCLK.

#### MASTER IN SLAVE OUT PIN (MISO)

The MISO pin sends data to an SPI-enabled MCU. It is a digital tri-state output used to shift serial data to the microcontroller. Data on this output pin changes on the positive edge of the SCLK. When  $\overline{CS}$  is High, this pin will remain in the high-impedance state.

#### CHIP SELECT PIN ( $\overline{CS}$ )

$\overline{CS}$  is an active low digital input. It must remain low during a valid SPI communication and allow for several devices to be connected in the same SPI bus without contention. A rising edge on  $\overline{CS}$  signals the end of the transmission and the moment the data shifted in is latched. A valid transmission must consist of 8 bits only.

While in STOP Mode, a low-to-high level transition on this pin will generate a wake-up condition for the 33912.

#### ANALOG MULTIPLEXER PIN (ADOUT0)

The ADOUT0 pin can be configured via the SPI to allow the MCU A/D converter to read the several inputs of the Analog Multiplexer, including the VSENSE, L1, L2, L3, L4 input voltages, and the internal junction temperature.

#### CURRENT SENSE AMPLIFIER PIN (ADOUT1)

The ADOUT1 pin is an analog interface to the MCU A/D converter. It allows the MCU to read the output of the current sense amplifier.

#### PWM INPUT CONTROL PIN (PWMIN)

This digital input can control the high sides and low sides drivers in Normal Request and Normal Mode.

To enable PWM control, the MCU must perform a write operation to the High Side Control Register (HSCR) or the Low Side Control Register (LSCR).

This pin has an internal 20  $\mu$ A current pull-up.



**RESET PIN ( $\overline{\text{RST}}$ )**

This bidirectional pin is used to reset the MCU in case the 33912 detects a reset condition, or to inform the 33912 that the MCU has just been reset. After release of the  $\overline{\text{RST}}$  pin, Normal Request Mode is entered.

The  $\overline{\text{RST}}$  pin is an active low filtered input and output formed by a weak pull-up and a switchable pull-down structure which allows this pin to be shorted either to  $V_{\text{DD}}$  or to GND during software development, without the risk of destroying the driver.

**INTERRUPT PIN ( $\overline{\text{IRQ}}$ )**

The  $\overline{\text{IRQ}}$  pin is a digital output used to signal events or faults to the MCU while in Normal and Normal Request mode or to signal a wake-up from Stop mode. This active low output will transition to high only after the interrupt is acknowledged by a SPI read of the respective status bits.

**WATCHDOG CONFIGURATION PIN (WDCONF)**

The WDCONF pin is the configuration pin for the internal watchdog. A resistor can be connected to this pin to configure the window watchdog period. When connected directly to ground, the watchdog will be disabled. When this pin is left open, the watchdog period is fixed to its lower precision internal default value (150 ms typical).

**GROUND CONNECTION PINS (AGND, PGND, LGND)**

The AGND, PGND and LGND pins are the Analog and Power ground pins.

The AGND pin is the ground reference of the voltage regulator and the current sense module.

The PGND and LGND pins are used for high current load return as in the relay-drivers and LIN interface pin.

Note: PGND, AGND and LGND pins must be connected together.

**CURRENT SENSE AMPLIFIER INPUT PINS (ISENSEH AND ISENSEL)**

The ISENSEH and ISENSEL pins are the input pins of a ground compatible differential amplifier designed to be used to sense the voltage drop over a shunt resistor. The main purpose of this amplifier is to implement accurate current sensors. The gain of the differential amplifier can be set by SPI.

**LOW SIDE PINS (LS1 AND LS2)**

LS1 and LS2 are the low side driver outputs. Those outputs are short-circuit protected and include active clamp circuitry to drive inductive loads. Due to the energy clamp voltage on this pin, it can raise above the battery level when switched off. The switches are controlled through the SPI and

can be configured to respond to a signal applied to the PWMIN input pin.

Both low side switches are protected against overheating. In case of VS1 disconnection and the low sides are still supplied by  $V_{\text{BAT}}$  through a load, both low sides will have a VDS voltage equal to the clamping value, as stated in the specification.

**DIGITAL/ANALOG PINS (L1, L2, L3 AND L4)**

The Lx pins are multi purpose inputs. They can be used as digital inputs, which can be sampled by reading the SPI and used for wake-up when 33912 is in low power mode or used as analog inputs for the analog multiplexer. When used to sense voltage outside the module, a 33 kohm series resistor must be used on each input.

When used as wake-up inputs L1-L4 can be configured to operate in cyclic-sense mode. In this mode one or both of the high side switches are configured to be periodically turned on and sample the wake-up inputs. If a state change is detected between two cycles a wake-up is initiated. The 33912 can also wake-up from Stop or Sleep by a simple state change on L1-L4.

When used as analog inputs, the voltage present on the Lx pins is scaled down by an selectable internal voltage divider and can be routed to the ADOUT0 output through the analog multiplexer.

Note: If an Lx input is selected in the analog multiplexer, it will be disabled as a digital input and remains disabled in low power mode. No wake-up feature is available in that condition.

When an Lx input is not selected in the analog multiplexer, the voltage divider is disconnected from that input.

**HIGH SIDE OUTPUT PINS (HS1 AND HS2)**

These two high side switches are able to drive loads such as relays or lamps. Their structures are connected to the VS2 supply pin. The pins are short-circuit protected and both outputs are also protected against overheating.

HS1 and HS2 are controlled by SPI and can respond to a signal applied to the PWMIN input pin.

HS1 and HS2 outputs can also be used during low-power mode for the cyclic-sense of the wake inputs.

**POWER SUPPLY PINS (VS1 AND VS2)**

Those are the battery level voltage supply pins. In an application, VS1 and VS2 pins must be protected against reverse battery connection and negative transient voltages with external components. These pins sustain standard automotive voltage conditions such as a load dump at 40 V.

The high side switches (HS1 and HS2) are supplied by the VS2 pin. All other internal blocks are supplied by the VS1 pin.

**VOLTAGE SENSE PIN (VSENSE)**

This input can be connected directly to the battery line. It is protected against battery reverse connection. The voltage present in this input is scaled down by an internal voltage divider, and can be routed to the ADOUT0 output pin and used by the MCU to read the battery voltage.

The ESD structure on this pin allows for excursion up to +40 V and down to -27 V, allowing this pin to be connected directly to the battery line. It is strongly recommended to connect a 10 kohm resistor in series with this pin for protection purposes.

**HALL SENSOR SWITCHABLE SUPPLY PIN (HVDD)**

This pin provides a switchable supply for external hall sensors. While in Normal Mode, this current limited output can be controlled through the SPI.

The HVDD pin needs to be connected to an external capacitor to stabilize the regulated output voltage.

**+5V MAIN REGULATOR OUTPUT PIN (VDD)**

An external capacitor has to be placed on the VDD pin to stabilize the regulated output voltage. The VDD pin is intended to supply a microcontroller. The pin is current limited against shorts to GND and over-temperature protected.

During Stop mode, the voltage regulator does not operate with its full drive capabilities and the output current is limited.

During Sleep mode, the regulator output is completely shut down.

## FUNCTIONAL DEVICE OPERATIONS

### OPERATIONAL MODES

#### INTRODUCTION

The 33912 offers three main operating modes: Normal (Run), Stop, and Sleep (Low Power). In Normal mode, the device is active and is operating under normal application conditions. The Stop and Sleep modes are low power modes with wake-up capabilities.

In Stop mode, the voltage regulator still supplies the MCU with  $V_{DD}$  (limited current capability), while in Sleep mode the voltage regulator is turned off ( $V_{DD} = 0$  V).

Wake-up from Stop mode is initiated by a wake-up interrupt. Wake-up from Sleep mode is done by a reset and the voltage regulator is turned back on.

The selection of the different modes is controlled by the MOD1:2 bits in the Mode Control Register (MCR).

[Figure 14](#) describes how transitions are done between the different operating modes. [Table 6, 29](#), gives an overview of the operating modes.

#### RESET MODE

The 33912 enters the Reset mode after a power up. In this mode, the  $\overline{RST}$  pin is low for 1.0 ms (typical value). After this delay, it enters the Normal Request mode and the  $\overline{RST}$  pin is driven high.

The Reset mode is entered if a reset condition occurs ( $V_{DD}$  low, watchdog trigger fail, after wake-up from Sleep mode, Normal Request mode timeout occurs).

#### NORMAL REQUEST MODE

This is a temporary mode automatically accessed by the device after the Reset mode, or after a wake-up from Stop mode.

In Normal Request mode, the VDD regulator is ON, the RESET pin is High, and the LIN is operating in RX Only mode.

As soon as the device enters in the Normal Request mode an internal timer is started for 150 ms (typical value). During these 150 ms, the MCU must configure the Timing Control Register (TIMCR) and the Mode Control Register (MCR) with MOD2 and MOD1 bits set = 0, to enter the Normal mode. If within the 150 ms timeout, the MCU does not command the 33912 to Normal mode, it will enter in Reset mode. If the WDCONF pin is grounded in order to disable the watchdog function, it goes directly in Normal mode after the Reset mode.

#### NORMAL MODE

In Normal mode, all 33912 functions are active and can be controlled by the SPI interface and the PWMIN pin.

The VDD regulator is ON and delivers its full current capability.

If an external resistor is connected between the WDCONF pin and the Ground, the window watchdog function will be enabled.

The wake-up inputs (L1-L4) can be read as digital inputs or have its voltage routed through the analog-multiplexer.

The LIN interface has slew rate and timing compatible with the LIN protocol specification 2.0, 2.1 and SAEJ2602. The LIN bus can transmit and receive information.

The high side and low side switches are active and have PWM capability according to the SPI configuration.

The interrupts are generated to report failures for  $V_{SUP}$  over/under-voltage, thermal shutdown, or thermal shutdown prewarning on the main regulator.

#### SLEEP MODE

The Sleep mode is a low power mode. From Normal mode, the device enters into Sleep mode by sending one SPI command through the Mode Control Register (MCR), or ( $V_{DD}$  low > 150 ms) with  $V_{SUV} = 0$ . When in Reset mode, a  $V_{DD}$  under-voltage condition with no  $V_{SUP}$  undervoltage ( $V_{SUV} = 0$ ) will send the device to Sleep mode. All blocks are in their lowest power consumption condition. Only some wake-up sources (wake-up inputs with or without cyclic sense, forced wake-up and LIN receiver) are active. The 5.0 V regulator is OFF. The internal low-power oscillator may be active if the IC is configured for cyclic-sense. In this condition, one of the high side switches is turned on periodically and the wake-up inputs are sampled.

Wake-up from Sleep mode is similar to a power-up. The device goes in Reset mode except that the SPI will report the wake-up source and the BATFAIL flag is not set.

#### STOP MODE

The Stop mode is the second low power mode, but in this case the 5.0 V regulator is ON with limited current drive capability. The application MCU is always supplied while the 33912 is operating in Stop mode.

The device can enter into Stop mode only by sending the SPI command. When the application is in this mode, it can wake-up from the 33912 side (for example: cyclic sense, force wake-up, LIN bus, wake inputs) or the MCU side ( $\overline{CS}$ ,  $\overline{RST}$  pins). Wake-up from Stop mode will transition the 33912 to Normal Request mode and generates an interrupt except if the wake-up event is a low to high transition on the  $\overline{CS}$  pin or comes from the  $\overline{RST}$  pin.

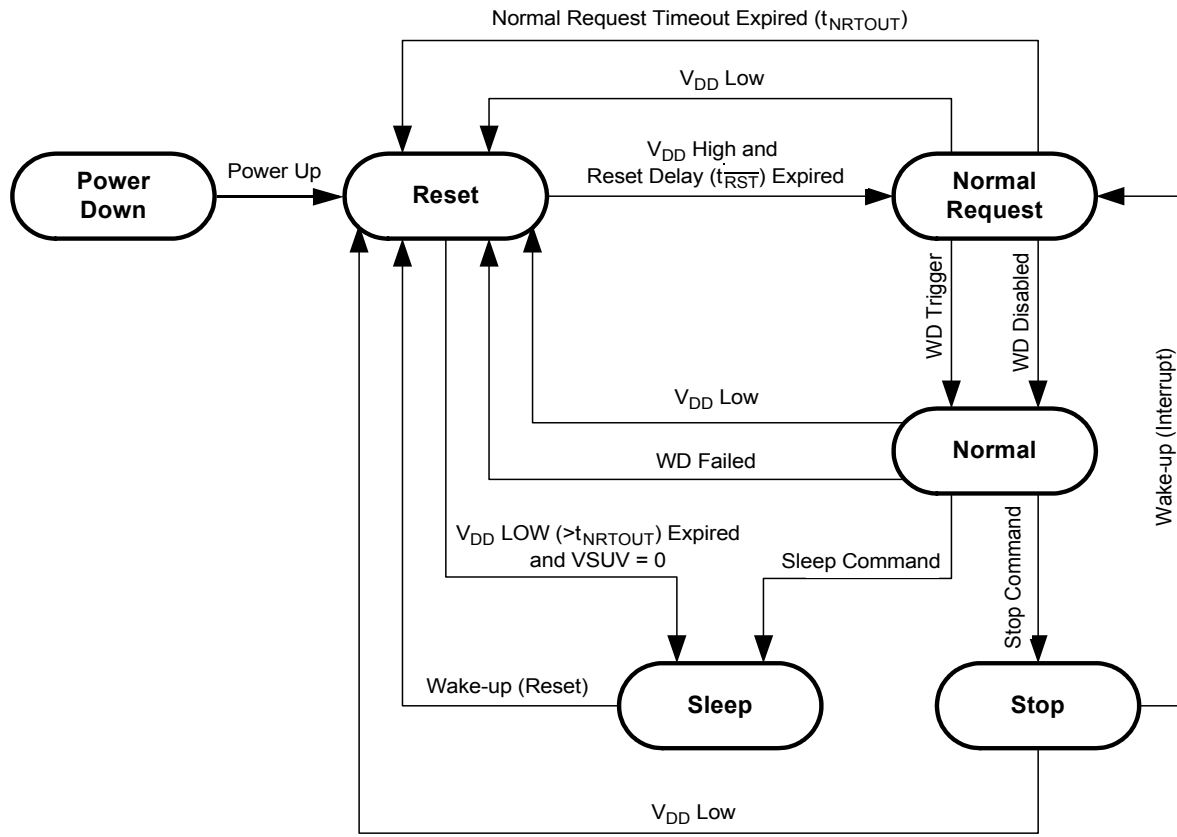
**Legend**

WD: Watchdog

WD Disabled: Watchdog disabled (WDCONF pin connected to GND)

WD Trigger: Watchdog is triggered by SPI command

WD Failed: No watchdog trigger or trigger occurs in closed window

Stop Command: Stop command sent via SPI

Sleep Command: Sleep command sent via SPI

Wake-up from Stop Mode: L1, L2, L3 or L4 state change, LIN bus wake-up, Periodic wake-up,  $\overline{CS}$  rising edge wake-up or  $\overline{RST}$  wake-up.

Wake-up from Sleep Mode: L1, L2, L3 or L4 state change, LIN bus wake-up, Periodic wake-up.

**Figure 14. Operating Modes and Transitions**

**Table 6. Operating Modes Overview**

Function	Reset Mode	Normal Request Mode	Normal Mode	Stop Mode	Sleep Mode
VDD	Full	Full	Full	Stop	-
HVDD	-	SPI <sup>(63)</sup>	SPI	-	-
LSx	-	SPI/PWM <sup>(64)</sup>	SPI/PWM	-	-
HSx	-	SPI/PWM <sup>(64)</sup>	SPI/PWM	Note <sup>(65)</sup>	Note <sup>(66)</sup>
Analog Mux	-	SPI	SPI	-	-
Lx	-	Inputs	Inputs	Wake-up	Wake-up
Current Sense	On	On	On	-	-
LIN	-	Rx-Only	Full/Rx-Only	Rx-Only/Wake-up	Wake-up
Watchdog	-	150 ms (typ.) timeout	On <sup>(67)</sup> /Off	-	-
Voltage Monitoring	V <sub>SUP</sub> /V <sub>DD</sub>	V <sub>SUP</sub> /V <sub>DD</sub>	V <sub>SUP</sub> /V <sub>DD</sub>	V <sub>DD</sub>	-

**Notes**

- 63. Operation can be enabled/controlled by the SPI.
- 64. Operation can be controlled by the PWMIN input.
- 65. HSx switches can be configured for cyclic sense operation in Stop mode.
- 66. HSx switches can be configured for cyclic sense operation in Sleep mode.
- 67. Windowing operation when enabled by an external resistor.

**INTERRUPTS**

Interrupts are used to signal a microcontroller that a peripheral needs to be serviced. The interrupts which can be generated, change according to the operating mode. While in Normal and Normal Request modes, the 33912 signals through interrupts special conditions which may require a MCU software action. Interrupts are not generated until all pending wake-up sources are read in the Interrupt Source Register (ISR).

While in Stop mode, interrupts are used to signal wake-up events. Sleep mode does not use interrupts. Wake-up is performed by powering-up the MCU. In Normal and Normal Request mode the wake-up source can be read by SPI.

The interrupts are signaled to the MCU by a low logic level of the IRQ pin, which will remain low until the interrupt is acknowledged by a SPI read command of the ISR register. The IRQ pin will then be driven high.

Interrupts are only asserted while in Normal, Normal Request and Stop mode. Interrupts are not generated while the RST pin is low.

The following is a list of the interrupt sources in Normal and Normal Request modes. Some of these can be masked by writing to the SPI - Interrupt Mask Register (IMR).

**Low-voltage Interrupt:**

Signals when the supply line (VS1) voltage drops below the VSUV threshold (V<sub>SUV</sub>).

**High-voltage Interrupt:**

Signals when the supply line (VS1) voltage increases above the VSOV threshold (V<sub>SOV</sub>).

**Over-temperature Prewarning:**

Signals when the 33912 temperature has reached the pre-shutdown warning threshold. It is used to warn the MCU that an over-temperature shutdown in the main 5.0 V regulator is imminent.

**LIN Over-temperature Shutdown / TXD Stuck At Dominant / RXD Short-circuit:**

These signal fault conditions within the LIN interface will cause the LIN driver to be disabled. In order to restart the operation, the fault must be removed and TXD must go recessive.

**High Side Over-temperature Shutdown:**

Signals a shutdown in the high side outputs.

**Low Side Over-temperature Shutdown:**

Signals a shutdown in the low side outputs.

## RESET

To reset a MCU the 33912 drives the  $\overline{\text{RST}}$  pin low for the time the reset condition lasts.

After the reset source is removed, the state machine will drive the RST output low for at least 1.0ms (typical value) before driving it high.

In the 33912, four main reset sources exist:

### 5.0 V Regulator Low-voltage-Reset ( $V_{\overline{\text{RSTTH}}}$ )

The 5.0 V regulator output  $V_{\text{DD}}$  is continuously monitored against brown outs. If the supply monitor detects that the voltage at the VDD pin has dropped below the reset threshold  $V_{\overline{\text{RSTTH}}}$  the 33912 will issue a reset. In case of over-temperature, the voltage regulator will be disabled and the voltage monitoring will issue a VDDOT Flag independently of the  $V_{\text{DD}}$  voltage.

### Window Watchdog Overflow

If the watchdog counter is not properly serviced while its window is open, the 33912 will detect an MCU software run-away and will reset the microcontroller.

### Wake-up From Sleep Mode

During Sleep mode, the 5V regulator is not active, hence all wake-up requests from Sleep mode require a power-up/reset sequence.

### External Reset

The 33912 has a bidirectional reset pin which drives the device to a safe state (same as Reset mode) for as long as this pin is held low. The  $\overline{\text{RST}}$  pin must be held low long enough to pass the internal glitch filter and get recognized by the internal reset circuit. This functionality is also active in Stop mode.

After the  $\overline{\text{RST}}$  pin is released, there is no extra  $t_{\overline{\text{RST}}}$  to be considered.

## WAKE-UP CAPABILITIES

Once entered into one of the low-power modes (Sleep or Stop) only wake-up sources can bring the device into Normal mode operation.

In Stop mode, a wake-up is signaled to the MCU as an interrupt, while in Sleep mode the wake-up is performed by activating the 5.0 V regulator and resetting the MCU. In both cases the MCU can detect the wake-up source by accessing the SPI registers and reading the Interrupt Source Register. There is no specific SPI register bit to signal a  $\overline{\text{CS}}$  wake-up or external reset. If necessary this condition is detected by excluding all other possible wake-up sources.

### Wake-up from Wake-up inputs (L1-L4) with cyclic sense disabled

The wake-up lines are dedicated to sense state changes of external switches and wake-up the MCU (in Sleep or Stop mode).

In order to select and activate direct wake-up from Lx inputs, the Wake-up Control Register (WUCR) must be configured with appropriate LxWE inputs enabled or disabled. The wake-up input's state is read through the Wake-up Status Register (WUSR).

Lx inputs are also used to perform cyclic-sense wake-up.

Note: Selecting an Lx input in the analog multiplexer before entering low power mode will disable the wake-up capability of the Lx input

### Wake-up from Wake-up inputs (L1-L4) with cyclic sense timer enabled

The SBCLIN can wake-up at the end of a cyclic sense period if on one of the four wake-up input lines (L1-L4) a state change occurs. One or both HSx switch can be activated in Sleep or Stop modes from an internal timer. Cyclic sense and force wake-up are exclusive. If cyclic sense is enabled, the force wake-up can not be enabled.

In order to select and activate the cyclic sense wake-up from Lx inputs, before entering in low power modes (Stop or Sleep modes), the following SPI set-up has to be performed:

In WUCR: select the Lx input to WU-enable.

In HSCR: enable the desired HSx.

- In TIMCR: select the  $\overline{\text{CS/WD}}$  bit and determine the cyclic sense period with CYSTx bits.
- Perform Goto Sleep/Stop command.

### Forced Wake-up

The 33912 can wake-up automatically after a predetermined time spent in Sleep or Stop mode. Cyclic sense and Forced wake-up are exclusive. If Forced wake-up is enabled, the Cyclic Sense can not be enabled.

To determine the wake-up period, the following SPI set-up has to be sent before entering in low power modes:

- In TIMCR: select the  $\overline{\text{CS/WD}}$  bit and determine the low power mode period with CYSTx bits.
- In HSCR: all HSx bits must be disabled.

### $\overline{\text{CS}}$ Wake-up

While in Stop mode, a rising edge on the  $\overline{\text{CS}}$  will cause a wake-up. The  $\overline{\text{CS}}$  wake-up does not generate an interrupt, and is not reported on SPI.

### LIN Wake-up

While in the low-power mode, the 33912 monitors the activity on the LIN bus. A dominant pulse larger than  $t_{\text{PROPWL}}$  followed by a dominant to recessive transition will cause a LIN wake-up. This behavior protects the system from a short to ground bus condition. The bit RXONLY = 1 from LINCR Register disables the LIN wake-up from Stop mode.



## **RST Wake-up**

While in Stop mode, the 33912 can wake-up when the  $\overline{\text{RST}}$  pin is held low long enough to pass the internal glitch filter. Then, the 33912 will change to Normal Request or Normal modes depending on the WDCONF pin configuration. The  $\overline{\text{RST}}$  wake-up does not generate an interrupt and is not reported via SPI.

From Stop mode, the following wake-up events can be configured:

- Wake-up from Lx inputs without cyclic sense
- Cyclic sense wake-up inputs
- Force wake-up
- $\overline{\text{CS}}$  wake-up
- LIN wake-up
- $\overline{\text{RST}}$  wake-up

From Sleep mode, the following wake-up events can be configured:

- Wake-up from Lx inputs without cyclic sense
- Cyclic sense wake-up inputs
- Force wake-up
- LIN wake-up

## **WINDOW WATCHDOG**

The 33912 includes a configurable window watchdog which is active in Normal mode. The watchdog can be configured by an external resistor connected to the WDCONF pin. The resistor is used to achieve higher precision in the timebase used for the watchdog.

SPI clears are performed by writing through the SPI in the MOD bits of the Mode Control Register (MCR).

During the first half of the SPI timeout, watchdog clears are not allowed, but after the first half of the SPI timeout window, the clear operation opens. If a clear operation is performed outside the window, the 33912 will reset the MCU, in the same way as when the watchdog overflows.

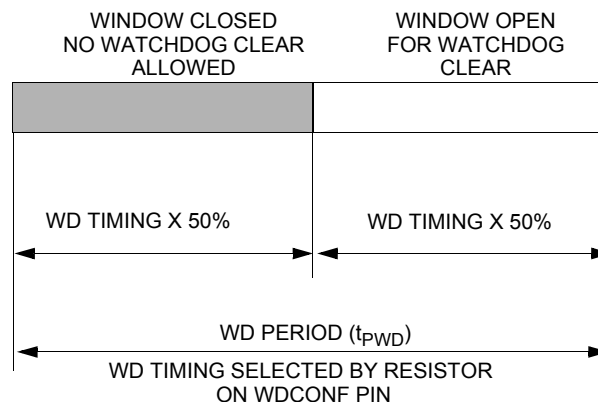

**Figure 15. Window Watchdog Operation**

To disable the watchdog function in Normal mode the user must connect the WDCONF pin to ground. This measure effectively disables Normal Request mode. The WDOFF bit in the Watchdog Status Register (WDSR) will be set. This condition is only detected during Reset mode.

If neither a resistor nor a connection to ground is detected, the watchdog falls back to the internal lower precision timebase of 150 ms (typ.) and signals the faulty condition through the Watchdog Status Register (WDSR).

The watchdog timebase can be further divided by a prescaler which can be configured by the Timing Control Register (TIMCR). During Normal Request mode, the window watchdog is not active but there is a 150 ms (typ.) timeout for leaving the Normal Request mode. In case of a timeout, the 33912 will enter into Reset mode, resetting the microcontroller before entering again into Normal Request mode.

## **FAULTS DETECTION MANAGEMENT**

The 33912 has the capability to detect faults like an over or under-voltage on VS1, TxD in permanent Dominant State, Over-temperature on HS, LIN. It is able to take corrective actions accordingly. Most of faults are monitoring through SPI and the Interrupt pin. The microcontroller can also take actions.

The following table summarizes all fault sources the device is able to detect with associated conditions. The status for a device recovery and the SPI or pins monitoring are also described.

Table 7. Fault Detection Management Conditions

BLOCK	FAULT	MODE	CONDITION	FALLOUT	RECOVERY	MONITORING <sup>(69)</sup>	
						REG (FLAG, BIT)	INTERRUPT
Power Supply	BATTERY FAIL	All modes	$V_{SUP} < 3.0$ V (typ) then power-up	-	Condition gone	VSR (BATFAIL, 0)	-
	VSUP OVER-VOLTAGE	Normal, Normal Request	$V_{SUP} > 19.25$ V (typ)	In Normal mode, HS and LS shutdown if bit HVSE=1 (reg MCR)	Condition gone, to re-enable HS or LS write to HSCR or LSCR registers	VSR (VSOV,3)	IRQ low + ISR (0101) <sup>(70)</sup>
	VSUP UNDER-VOLTAGE		$V_{SUP} < 6.0$ V (typ)	-	Condition gone	VSR (VSUV,2)	IRQ low + ISR (0101)
	VDD UNDER-VOLTAGE	All except Sleep	$V_{DD} < 4.5$ V (typ)	Reset <sup>(68)</sup>		-	-
	VDD OVER-TEMP PREWARNING	All except Low Power modes	Temperature $> 115^{\circ}\text{C}$ (typ)	-		VSR (VDDOT,1)	IRQ low + ISR (0101)
	VDD OVER-TEMPERATURE		Temperature $> 170^{\circ}\text{C}$ (typ)	VDD shutdown, Reset then Sleep	-	-	
LIN	RXD PIN SHORT CIRCUIT	Normal, Normal Request	RXD pin shorted to GND or 5 V	LIN trans shutdown	LIN transmitter re-enabled once the condition is gone and TXD is high	LINSR, (RXSHORT,3)	IRQ low + ISR (0100) <sup>(70)</sup>
	TXD PIN PERMANENT DOMINANT		TXD pin low for more than 1s (typ)	LIN transmitter shutdown		LINSR (TXDOM,2)	
	LIN DRIVER OVER-TEMPERATURE		Temperature $> 160^{\circ}\text{C}$ (typ)	-		LINSR (LINOT,1)	
High Side	HIGH SIDE DRIVERS OVER-TEMPERATURE	Normal, Normal Request	Temperature $> 160^{\circ}\text{C}$ (typ)	Both HS thermal shutdown	Condition gone, to re-enable HS write to HSCR reg	All flags in HSSR are set	IRQ low + ISR (0010) <sup>(70)</sup>
	HS1 OPEN-LOAD DETECTION		Current through HSx $< 5.0$ mA (typ)	-	Condition gone	HSSR (HS1OP,1)	-
	HS2 OPEN-LOAD DETECTION			-		HSSR (HS2OP,3)	
	HS1 OVER-CURRENT		Current through HSx tends to rise above the current limit 60 mA (min)	HSx on with limited current capability 60 mA (min)		HSSR (HS1CL,0)	
	HS2 OVER-CURRENT				HSSR (HS2CL,2)		
Low Side	LOW SIDE DRIVERS OVER-TEMPERATURE	Normal, Normal Request	Temperature $> 160^{\circ}\text{C}$ (typ)	Both LS thermal shutdown	Condition gone, to re-enable LS write to LSCR reg	All flags in LSSR are set	
	LS1 OPEN-LOAD		Current through LSx $< 7.5$ mA (typ)	-	-	LSSR (LS1OP,1)	-
	LS2 OPEN-LOAD			-		LSSR (LS2OP,3)	
	LS1 OVER-CURRENT		Current through LSx tends to rise above the current limit 160 mA (min)	LSx on with limited current capability 160 mA (min)		LSSR (LS1CL,0)	
	LS2 OVER-CURRENT				LSSR (LS2CL,2)		
Watchdog	NORMAL REQUEST TIME-OUT EXPIRED	Normal Request	The MCU did not command the device to Normal mode within the 150 ms timeout after reset	Reset	-	-	
	WATCHDOG TIMEOUT	Normal	WD timeout or WD clear within the window closed	Reset	-	WDSR (WDTO, 3)	-
	WATCHDOG ERROR	Normal	WDCONF pin is floating	WD internal lower precision timebase 150 ms (typ)	Connect WDCONF to a resistor or to GND	WDSR (WDERR, 2)	-

## Notes

68. When in Reset mode a VDD under-voltage condition combined with no  $V_{SUP}$  under-voltage ( $VSUV=0$ ) will send the device to Sleep mode.  
69. Registers to be read when back in Normal Request or Normal mode depending on the fault. Interrupts only generated in Normal, Normal Request and Stop modes  
70. Unless masked, If masked IRQ remains high and the ISR flags are not set.



## TEMPERATURE SENSE GAIN

The analog multiplexer can be configured via SPI to allow the ADOUT0 pin to deliver the internal junction temperature of the device.

The graph below illustrates the internal chip temp sense obtained per characterization at 3 temperatures with 3 different lots and 30 samples.

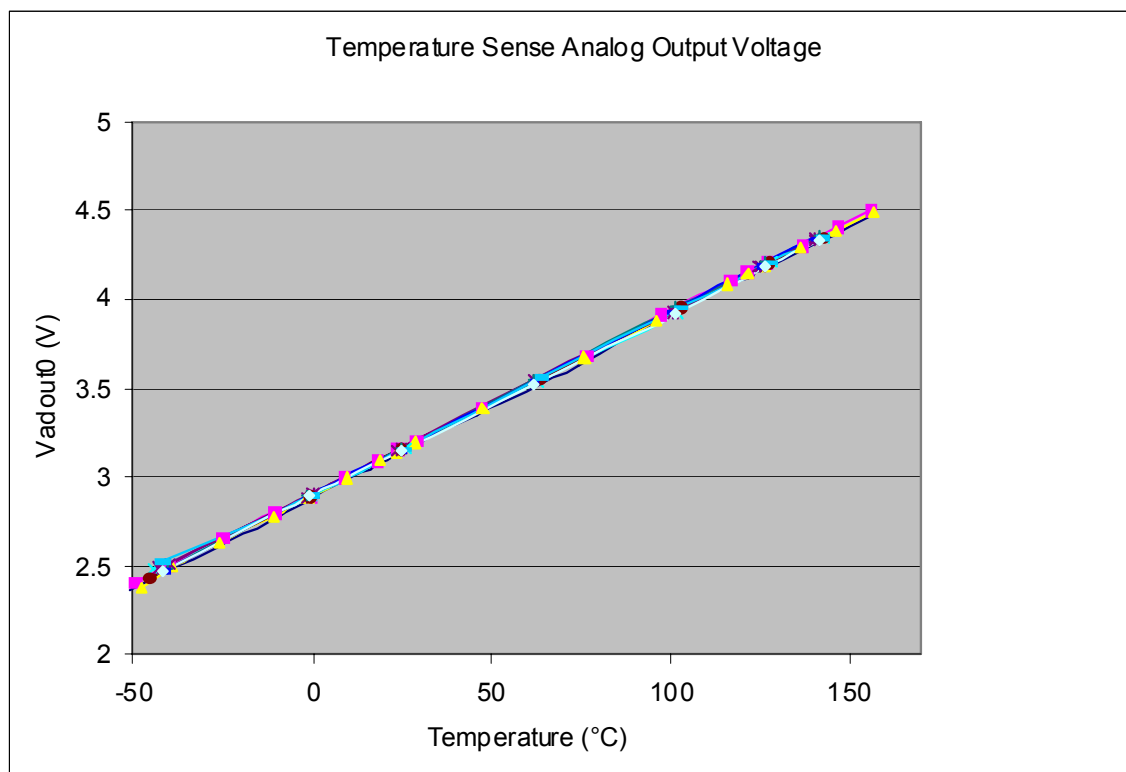

Figure 16. Temperature Sense Gain

## HIGH SIDE OUTPUT PINS HS1 AND HS2

These outputs are two high side drivers intended to drive small resistive loads or LEDs incorporating the following features:

- PWM capability (software maskable)
- Open load detection
- Current limitation
- Over-temperature shutdown (with maskable interrupt)
- High-voltage shutdown (software maskable)
- Cyclic sense

The high side switches are controlled by the bits HS1:2 in the High Side Control Register (HSCR).

### PWM Capability (direct access)

Each high side driver offers additional (to the SPI control) direct control via the PWMIN pin.

If both the bits HS1 and PWMHS1 are set in the High Side Control Register (HSCR), then the HS1 driver is turned on if the PWMIN pin is high and turned off if the PWMIN pin is low. This applies to HS2 configuring HS2 and PWMHS2 bits.

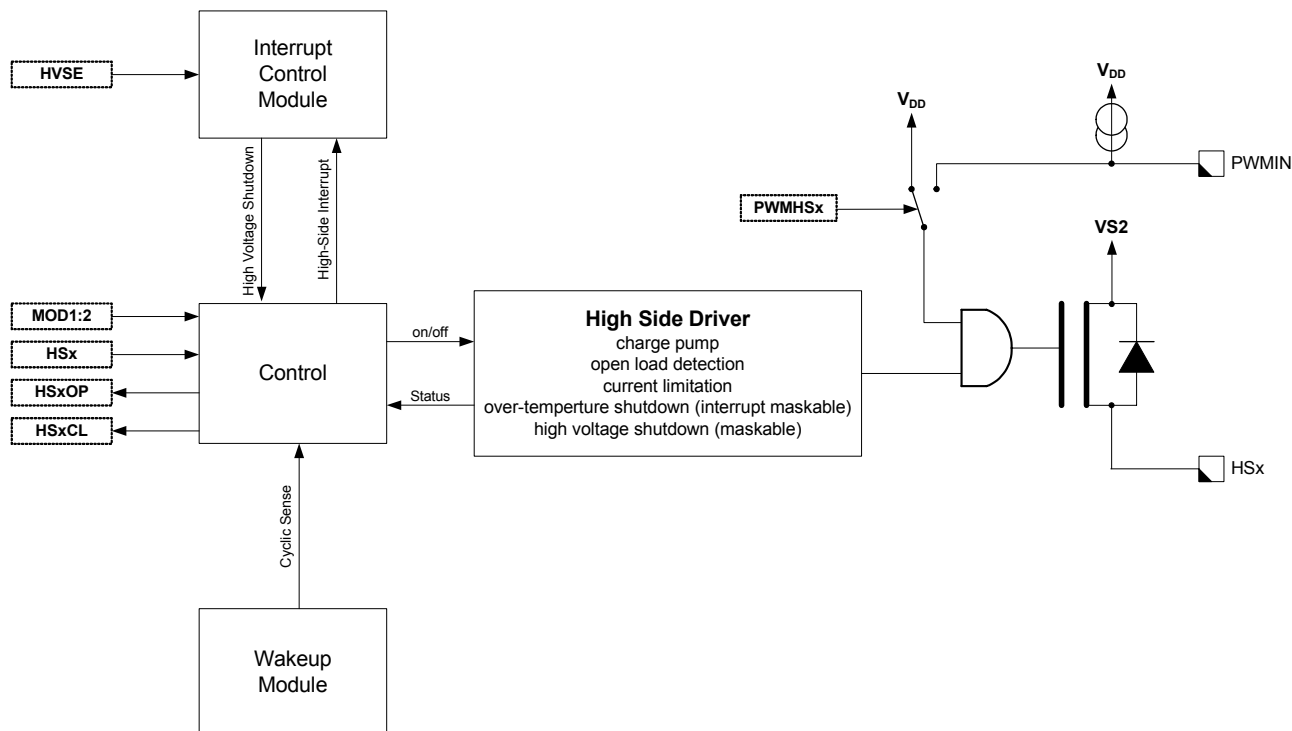

Figure 17. High Side Drivers HS1 and HS2

### Open Load Detection

Each high side driver signals an open load condition if the current through the high side is below the open load current threshold.

The open load condition is indicated with the bits HS1OP and HS2OP in the High Side Status Register (HSSR).

### Current Limitation

Each high side driver has an output current limitation. In combination with the over-temperature shutdown the high-side drivers are protected against over-current and short-circuit failures.

When the driver operates in the current limitation area, it is indicated with the bits HS1CL and HS2CL in the HSSR.

Note: If the driver is operating in current limitation mode, excessive power might be dissipated.

### Over-temperature Protection (HS Interrupt)

Both high side drivers are protected against over-temperature. In case of an over-temperature condition both high side drivers are shut down and the event is latched in the Interrupt Control Module. The shutdown is indicated as HS Interrupt in the Interrupt Source Register (ISR).

A thermal shutdown of the high side drivers is indicated by setting all HSxOP and HSxCL bits simultaneously.

If the bit HSM is set in the Interrupt Mask Register (IMR), then an interrupt (IRQ) is generated.

A write to the High Side Control Register (HSCR), when the over-temperature condition is gone, will re-enable the high side drivers.

### High-voltage Shutdown

In case of a high voltage condition and if the high voltage shutdown is enabled (bit HVSE in the Mode Control Register (MCR) is set both high side drivers are shut down.

A write to the High Side Control Register (HSCR), when the high voltage condition is gone, will re-enable the high side drivers.

### Sleep And Stop Mode

The high side drivers can be enabled to operate in Sleep and Stop mode for cyclic sensing. Also see [Table 6. Operating Modes Overview](#).

### LOW SIDE OUTPUT PINS LS1 AND LS2

These outputs are two low side drivers intended to drive relays incorporating the following features:

- PWM capability (software maskable)
- Open load detection
- Current limitation
- Over-temperature shutdown (with maskable interrupt)
- Active clamp (for driving relays)
- High-voltage shutdown (software maskable)

The low side switches are controlled by the bit LS1:2 in the Low Side Control Register (LSCR).

To protect the device against over-voltage when an inductive load (relay) is turned off. An active clamp will re-enable the low side FET if the voltage on the LS1 or LS2 pin exceeds a certain level.

### PWM Capability (direct access)

Each low side driver offers additional (to the SPI control) direct control via the PWMIN pin.

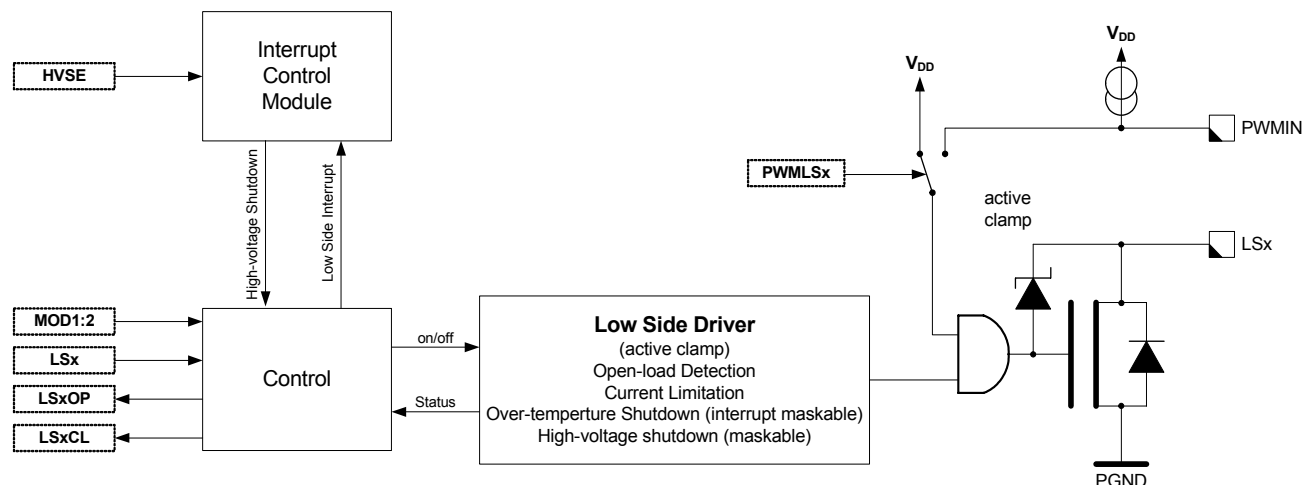

Figure 18. Low Side Drivers LS1 and LS2

### Open Load Detection

Each low side driver signals an open load condition if the current through the low side is below the open load current threshold.

The open load condition is indicated with the bit LS1OP and LS2OP in the Low Side Status Register (LSSR).

### Current Limitation

Each low side driver has a current limitation. In combination with the over-temperature shutdown the low side drivers are protected against over-current and short-circuit failures.

When the drivers operate in current limitation, this is indicated with the bits LS1CL and LS2CL in the LSSR.

Note: If the drivers are operating in current limitation mode excessive power might be dissipated.

### Over-temperature Protection (LS Interrupt)

Both low side drivers are protected against over-temperature. In case of an over-temperature condition both low side drivers are shut down and the event is latched in the Interrupt Control Module. The shutdown is indicated as an LS Interrupt in the Interrupt Source Register (ISR).

If the bit LSM is set in the Interrupt Mask Register (IMR) then an Interrupt (IRQ) is generated.

A write to the Low Side Control Register (LSCR), when the over-temperature condition is gone, will re-enable the low side drivers.

If both the bits LS1 and PWMLS1 are set in the Low Side Control Register (LSCR), then the LS1 driver is turned on if the PWMIN pin is high and turned off if the PWMIN pin is low. The same applies to the LS2 and PWMLS2 bits for the LS2 driver.

### High-voltage Shutdown

In case of a high-voltage condition and if the high-voltage shutdown is enabled (bit HVSE in the Mode Control Register (MCR) is set) both low sides drivers are shut down.

A write to the Low Side Control Register (LSCR), when the high-voltage condition is gone, will re-enable the low side drivers.

### Sleep And Stop Mode

The low side drivers are disabled in Sleep and Stop mode. Also see [Table 6, Operating Modes Overview](#).

### LIN PHYSICAL LAYER

The LIN bus pin provides a physical layer for single-wire communication in automotive applications. The LIN physical layer is designed to meet the LIN physical layer specification and has the following features:

- LIN physical layer 2.0, 2.1 and SAEJ2602 compliant
- Slew rate selection
- Over-temperature shutdown
- Advanced diagnostics

The LIN driver is a low side MOSFET with thermal shutdown. An internal pull-up resistor with a serial diode structure is integrated, so no external pull-up components are required for the application in a slave node. The fall time from dominant to recessive and the rise time from recessive to dominant is controlled. The symmetry between both slopes is guaranteed.

## LIN Pin

The LIN pin offers a high susceptibility immunity level from external disturbance, guaranteeing communication during external disturbance.

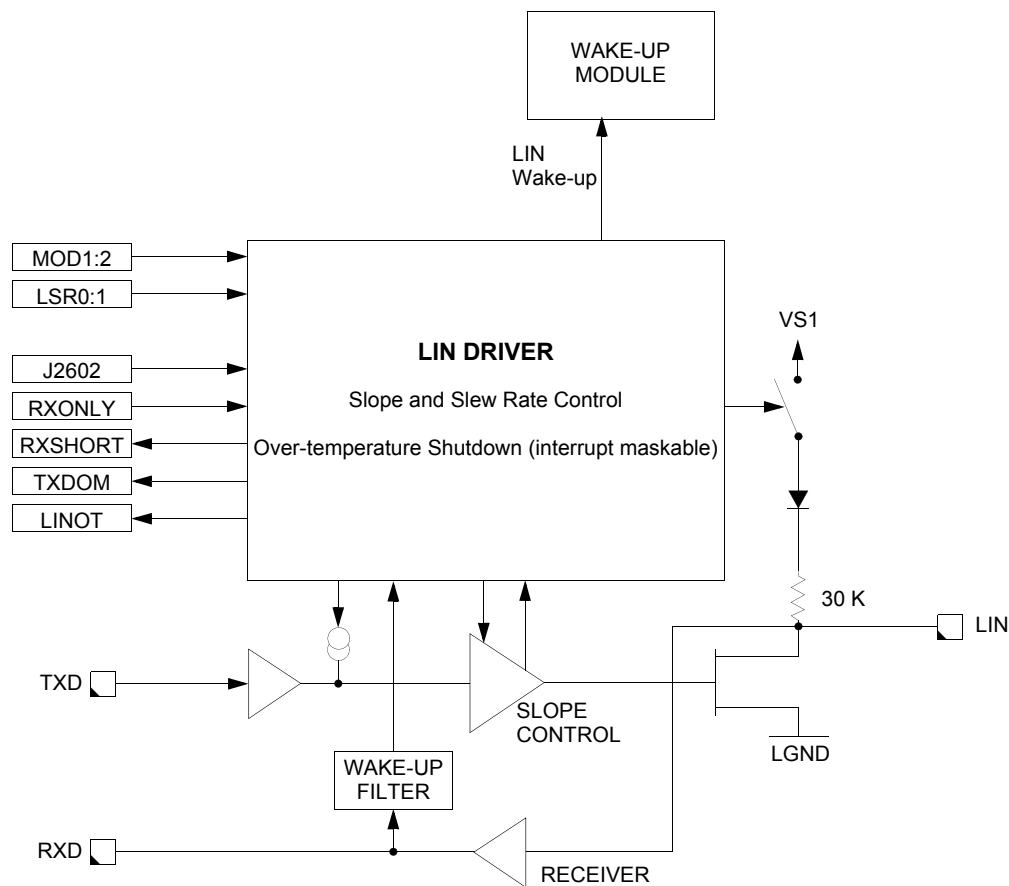

Figure 19. LIN Interface

### Slew Rate Selection

The slew rate can be selected for optimized operation at 10.4 and 20 kBit/s as well as a fast baud rate for test and programming. The slew rate can be adapted with the bits LSR1:0 in the LIN Control Register (LINCR). The initial slew rate is optimized for 20 kBit/s.

### J2602 Conformance

To be compliant with the SAE J2602-2 specification, the J2602 feature has to be enabled in the LINCR Register (bit DIS\_J2602 sets to 0). The LIN transmitter is disabled in case of a  $V_{SUP}$  under-voltage condition occurs and TXD is in Recessive State: the LIN bus goes in Recessive State and RXD goes high. The LIN transmitter is not disabled if TXD is in Dominant State. A deglitcher on  $V_{sup}$  ( $t_{J2602\_DEG}$ ) is implemented to avoid false switching.

If the (DIS\_J2602) bit is set to 1, the J2602 feature is disabled and the communication TXD-LIN-RXD works for

$V_{SUP}$  down to 4.6 V (typical value) and then the communication is interrupted.

The (DIS\_J2602) bit is set per default to 0.

### Over-temperature Shutdown (LIN Interrupt)

The output low side FET is protected against over-temperature conditions. In case of an over-temperature condition, the transmitter will be shut down and the LINOT bit in the LIN Status Register (LINSR) is set.

If the LINIM bit is set in the Interrupt Mask Register (IMR), an Interrupt IRQ will be generated.

The transmitter is automatically re-enabled once the condition is gone and TXD is high.

### RXD Short-circuit Detection (LIN Interrupt)

The LIN transceiver has a short-circuit detection for the RXD output pin. If the device transmits and in case of a short-

circuit condition, either 5.0 V or Ground, the RXSHORT bit in the LIN Status Register (LINSR) is set and the transmitter is shut down.

If the LINM bit is set in the Interrupt Mask Register (IMR), an Interrupt  $\overline{IRQ}$  will be generated.

The transmitter is automatically re-enabled once the condition is gone (transition on RXD) and TXD is high.

A read of the LIN Status Register (LINSR) without the RXD pin short-circuit condition will clear the bit RXSHORT.

#### TXD Dominant Detection (LIN Interrupt)

The LIN transceiver monitors the TXD input pin to detect a stuck in dominant (0 V) condition. In case of a stuck condition (TXD pin 0 V for more than 1 second (typ.)), the transmitter is shut down and the TXDOM bit in the LIN Status Register (LINSR) is set.

If the LINM bit is set in the IMR, an Interrupt  $\overline{IRQ}$  will be generated.

The transmitter is automatically re-enabled once TXD is high.

A read of the LIN Status Register (LINSR) with the TXD pin at 5.0 V will clear the bit TXDOM.

#### LIN Receiver Operation Only

While in Normal mode, the activation of the RXONLY bit disables the LIN TXD driver. In case of a LIN error condition, this bit is automatically set. If Stop mode is selected with this bit set, the LIN wake-up functionality is disabled and the RXD pin will reflect the state of the LIN bus.

#### STOP Mode And Wake-up Feature

During Stop mode operation, the transmitter of the physical layer is disabled. The receiver is still active and able to detect wake-up events on the LIN bus line.

A dominant level longer than  $T_{PROPWL}$  followed by a rising edge will generate a wake-up interrupt, and will be reported in the Interrupt Source Register (ISR). Also see [Figure 11](#), page 22.

#### SLEEP Mode And Wake-up Feature

During Sleep mode operation, the transmitter of the physical layer is disabled. The receiver must be active to detect wake-up events on the LIN bus line.

A dominant level longer than  $T_{PROPWL}$  followed by a rising edge will generate a system wake-up (Reset), and will be reported in the Interrupt Source Register (ISR). Also see [Figure 10](#), page 22.

## LOGIC COMMANDS AND REGISTERS

## 33912 SPI INTERFACE AND CONFIGURATION

The serial peripheral interface creates the communication link between a microcontroller (master) and the 33912.

The interface consists of four pins (see [Figure 20](#)):

- $\overline{CS}$ —Chip Select
- MOSI—Master-out Slave-in

- MISO—Master-in Slave-out
- SCLK—Serial Clock

A complete data transfer via the SPI consists of 1 byte. The master sends 4 bits of address (A3:A0) + 4 bits of control information (C3:C0) and the slave replies with 4 system status bits (VMS,LINS,HSS,LSS) + 4 bits of status information (S3:S0).

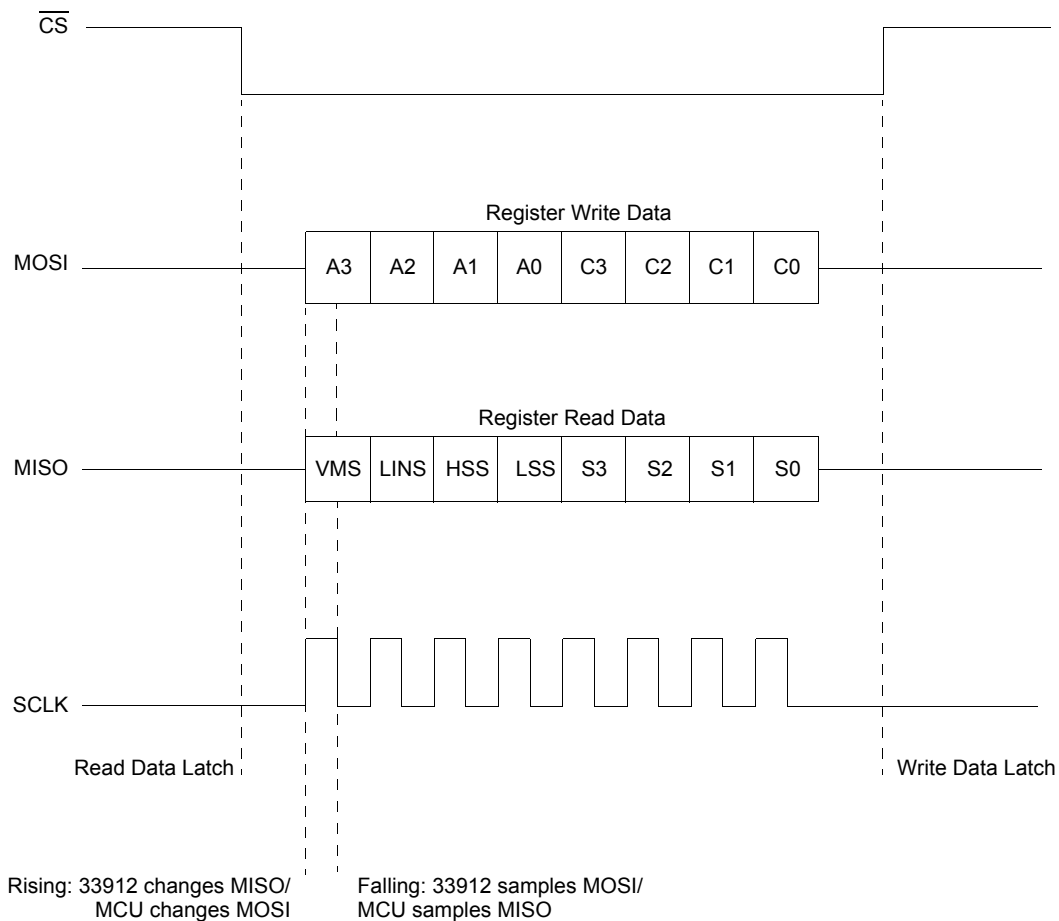

**Figure 20. SPI Protocol**

During the inactive phase of the  $\overline{CS}$  (HIGH), the new data transfer is prepared.

The falling edge of the  $\overline{CS}$  indicates the start of a new data transfer and puts the MISO in the low-impedance state and latches the analog status data (Register read data).

With the rising edge of the SPI clock (SCLK), the data is moved to MISO/MOSI pins. With the falling edge of the SPI clock (SCLK), the data is sampled by the receiver.

The data transfer is only valid if exactly 8 sample clock edges are present during the active (low) phase of  $\overline{CS}$ .

The rising edge of the Chip Select  $\overline{CS}$  indicates the end of the transfer and latches the write data (MOSI) into the register. The  $\overline{CS}$  high forces MISO to the high-impedance state.

Register reset values are described along with the reset condition. Reset condition is the condition causing the bit to be set to its reset value. The main reset conditions are:

- Power-On Reset (POR): the level at which the logic is reset and BATFAIL flag sets.
- Reset mode
- Reset done by the  $\overline{RST}$  pin (ext\_reset)

## SPI REGISTER OVERVIEW

Table 8. System Status Register

Adress(A3:A0)	Register Name / Read/Write Information		BIT			
			7	6	5	4
\$0 - \$F	SYSSR - System Status Register	R	VMS	LINS	HSS	LSS

[Table 9](#) summarizes the SPI Register content for Control Information (C3:C0)=W and status information (S3:S0) = R.

Table 9. SPI Register Overview

Adress(A3:A0)	Register Name / Read/Write Information		BIT			
			3	2	1	0
\$0	MCR - Mode Control Register	W	HVSE	0	MOD2	MOD1
	VSR - Voltage Status Register	R	VSOV	VSUV	VDDOT	BATFAIL
\$1	VSR - Voltage Status Register	R	VSOV	VSUV	VDDOT	BATFAIL
\$2	WUCR - Wake-up Control Register	W	L4WE	L3WE	L2WE	L1WE
	WUSR - Wake-up Status Register	R	L4	L3	L2	L1
\$3	WUSR - Wake-up Status Register	R	L4	L3	L2	L1
\$4	LINCR - LIN Control Register	W	DIS_J2602	RXONLY	LSR1	LSR0
	LINSR - LIN Status Register	R	RXSHORT	TXDOM	LINOT	0
\$5	LINSR - LIN Status Register	R	RXSHORT	TXDOM	LINOT	0
\$6	HSCR - High Side Control Register	W	PWMHS2	PWMHS1	HS2	HS1
	HSSR - High Side Status Register	R	HS2OP	HS2CL	HS1OP	HS1CL
\$7	HSSR - High Side Status Register	R	HS2OP	HS2CL	HS1OP	HS1CL
\$8	LSCR - Low Side Control Register	W	PWMLS2	PWMLS1	LS2	LS1
	LSSR - Low Side Status Register	R	LS2OP	LS2CL	LS1OP	LS1CL
\$9	LSSR - Low Side Status Register	R	LS2OP	LS2CL	LS1OP	LS1CL
\$A	TIMCR - Timing Control Register	W	CS/WD	WD2	WD1	WD0
	WDSR - Watchdog Status Register	R	WDTO	WDERR	WDOFF	WDWO
\$B	WDSR - Watchdog Status Register	R	WDTO	WDERR	WDOFF	WDWO
\$C	AMUXCR - Analog Multiplexer Control Register	W	LXDS	MX2	MX1	MX0
\$D	CFR - Configuration Register	W	HVDD	CYSX8	CSAZ	CSGS
\$E	IMR - Interrupt Mask Register	W	HSM	LSM	LINM	VMM
	ISR - Interrupt Source Register	R	ISR3	ISR2	ISR1	ISR0
\$F	ISR - Interrupt Source Register	R	ISR3	ISR2	ISR1	ISR0

**REGISTER DEFINITIONS****System Status Register - SYSSR**

The System Status Register (SYSSR) is always transferred with every SPI transmission and gives a quick system status overview. It summarizes the status of the Voltage Monitor Status (VMS), LIN Status (LINS), High Side Status (HSS), and the Low Side Status (LSS).

**Table 10. System Status Register**

	S7	S6	S5	S4
Read	VMS	LINS	HSS	LSS

**VMS - Voltage Monitor Status**

This read-only bit indicates that one or more bits in the VSR are set.

- 1 = Voltage Monitor bit set
- 0 = None

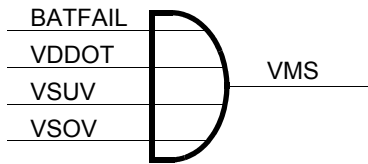
**Figure 21. Voltage Monitor Status****LINS - LIN Status**

This read-only bit indicates that one or more bits in the LINSR are set.

- 1 = LIN Status bit set
- 0 = None

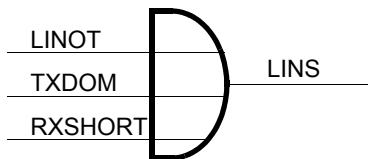
**Figure 22. LIN Status****HSS - High Side Switch Status**

This read-only bit indicates that one or more bits in the HSSR are set.

- 1 = High Side Status bit set
- 0 = None

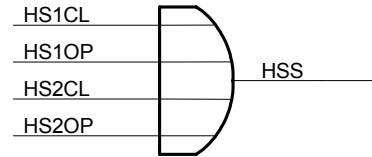
**Figure 23. High Side Status****LSS - Low Side Switch Status**

This read-only bit indicates that one or more bits in the LSSR are set.

- 1 = Low Side Status bit set
- 0 = None

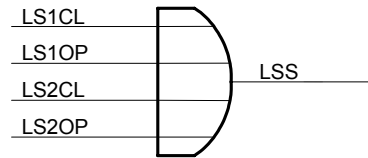
**Figure 24. Low Side Status****Mode Control Register - MCR**

The Mode Control Register (MCR) allows switching between the operation modes and to configure the 33912. Writing the MCR will return the VSR.

**Table 11. Mode Control Register - \$0**

	C3	C2	C1	C0
Write	HVSE	0	MOD2	MOD1
Reset Value	1	0	-	-
Reset Condition	POR	POR	-	-

**HVSE - High-voltage Shutdown Enable**

This write-only bit enables/disables automatic shutdown of the high side and the low side drivers during a high-voltage VSOV condition.

- 1 = automatic shutdown enabled
- 0 = automatic shutdown disabled



**MOD2, MOD1 - Mode Control Bits**

These write-only bits select the operating mode and allow clearing the watchdog in accordance with [Table 8](#) Mode Control Bits.

**Table 12. Mode Control Bits**

MOD2	MOD1	Description
0	0	Normal Mode
0	1	Stop Mode
1	0	Sleep Mode
1	1	Normal Mode + Watchdog Clear

**Voltage Status Register - VSR**

Returns the status of the several voltage monitors. This register is also returned when writing to the Mode Control Register (MCR).

**Table 13. Voltage Status Register - \$0/\$1**

	S3	S2	S1	S0
Read	VSOV	VSUV	VDDOT	BATFAIL

**VSOV -  $V_{SUP}$  Over-voltage**

This read-only bit indicates an over-voltage condition on the VS1 pin.

- 1 = Over-voltage condition.
- 0 = Normal condition.

**VSUV -  $V_{SUP}$  Under-voltage**

This read-only bit indicates an under-voltage condition on the VS1 pin.

- 1 = Under-voltage condition.
- 0 = Normal condition.

**VDDOT - Main Voltage Regulator Over-temperature Warning**

This read-only bit indicates that the main voltage regulator temperature reached the Over-temperature Prewarning Threshold.

- 1 = Over-temperature Prewarning
- 0 = Normal

**BATFAIL - Battery Fail Flag.**

This read-only bit is set during power-up and indicates that the 33912 had a Power-On-Reset (POR).

Any access to the MCR or VSR will clear the BATFAIL flag.

- 1 = POR Reset has occurred
- 0 = POR Reset has not occurred

**Wake-up Control Register - WUCR**

This register is used to control the digital wake-up inputs. Writing the WUCR will return the Wake-Up Status Register (WUSR).

**Table 14. Wake-Up Control Register - \$2**

	C3	C2	C1	C0
Write	L4WE	L3WE	L2WE	L1WE
Reset Value	1	1	1	1
Reset Condition	POR, Reset mode or ext_reset			

**LxWE - Wake-up Input x Enable**

This write-only bit enables/disables which Lx inputs are enabled. In Stop and Sleep mode the LxWE bit determines which wake inputs are active for wake-up. If one of the Lx inputs is selected on the analog multiplexer, the corresponding LxWE is masked to 0.

- 1 = Wake-up Input x enabled.
- 0 = Wake-up Input x disabled.

**Wake-up Status Register - WUSR**

This register is used to monitor the digital wake-up inputs and is also returned when writing to the WUCR.

**Table 15. Wake-up Status Register - \$2/\$3**

	S3	S2	S1	S0
Read	L4	L3	L2	L1

**Lx - Wake-up input x**

This read-only bit indicates the status of the corresponding Lx input. If the Lx input is not enabled, then the according Wake-up status will return 0.

After a wake-up from Stop or Sleep mode these bits also allow to determine which input has caused the wake-up, by first reading the Interrupt Status Register (ISR) and then reading the WUSR. The source of the wake-up is only reported on the first WUCR or WUSR access.

- 1 = Lx pin high, or Lx is the source of the wake-up.
- 0 = Lx pin low, disabled or selected as an analog input.

**LIN Control Register - LINCRC**

This register controls the LIN physical interface block. Writing the LIN Control Register (LINCRC) returns the LIN Status Register (LINSR).

**Table 16. LIN Control Register - \$4**

	C3	C2	C1	C0
Write	DIS_J2602	RXONLY	LSR1	LSR0
Reset Value	0	0	0	0
Reset Condition	POR	POR, Reset mode, ext_reset or LIN failure gone*	POR	

\* LIN failure gone: if LIN failure (over-temp, TXD/RXD short) was set, the flag resets automatically when the failure is gone.

**J2602 - LIN Dominant Voltage Select**

This write-only bit controls the J2602 circuitry. If the circuitry is enabled (bit sets to 0), the TXD-LIN-RXD communication works down to the battery under-voltage condition is detected. Below, the bus is in recessive state. If the circuitry is disabled (bit sets to 1), the communication TXD-LIN-RXD works down to 4.6 V (typical value).

- 0 = Enabled J2602 feature.
- 1 = Disabled J2602 feature.

**RXONLY - LIN Receiver Operation Only**

This write-only bit controls the behavior of the LIN transmitter.

In Normal mode, the activation of the RXONLY bit disables the LIN transmitter. In case of a LIN error condition, this bit is automatically set.

In Stop mode this bit disables the LIN wake-up functionality, and the RXD pin will reflect the state of the LIN bus.

- 1 = only LIN receiver active (Normal mode) or LIN wake-up disabled (Stop mode).
- 0 = LIN fully enabled.

**LSRx - LIN Slew-Rate**

This write-only bit controls the LIN driver slew-rate in accordance with [Table](#).

**Table 17. LIN Slew Rate Control**

LSR1	LSR0	Description
0	0	Normal Slew Rate (up to 20 kb/s)
0	1	Slow Slew Rate (up to 10 kb/s)
1	0	Fast Slew Rate (up to 100 kb/s)
1	1	Reserved

**LIN Status Register - LINSR**

This register returns the status of the LIN physical interface block and is also returned when writing to the LINCRC.

**Table 18. LIN Status Register - \$4/\$5**

	S3	S2	S1	S0
Read	RXSHORT	TXDOM	LINOT	0

**RXSHORT - RXD Pin Short-circuit**

This read-only bit indicates a short-circuit condition on the RXD pin (shorted either to 5.0 V or to Ground). The short-circuit delay must be a worst case of 8 $\mu$ s to be detected and to shut down the driver. To clear this bit, it must be read after the condition is gone (transition detected on RXD pin). The LIN driver is automatically re-enabled once the condition is gone and TXD is high.

- 1 = RXD short-circuit condition.
- 0 = None.

**TXDOM - TXD Permanent Dominant**

This read-only bit signals the detection of a TXD pin stuck at dominant (Ground) condition and the resultant shutdown in the LIN transmitter. This condition is detected after the TXD pin remains in dominant state for more than 1 second (typical value).

To clear this bit, it must be read after TXD has gone high. The LIN driver is automatically re-enabled once TXD goes High.

- 1 = TXD stuck at dominant fault detected.
- 0 = None.

**LINOT - LIN Driver Over-temperature**

This read-only bit signals that the LIN transceiver was shutdown due to over-temperature. The transmitter is automatically re-enabled after the over-temperature condition is gone and TXD is high. The LINOT bit is cleared after SPI read once the condition is gone.

- 1 = LIN over-temperature shutdown
- 0 = None

**High Side Control Register - HSCR**

This register controls the operation of the high side drivers. Writing to this register returns the High Side Status Register (HSSR).

**Table 19. High Side Control Register - \$6**

	C3	C2	C1	C0
Write	PWMHS2	PWMHS1	HS2	HS1
Reset Value	0	0	0	0
Reset Condition	POR		POR, Reset mode, ext_reset, HSx over-temp or (VSOV & HVSE)	

**PWMHSx - PWM Input Control Enable.**

This write-only bit enables/disables the PWMIN input pin to control the respective high side switch. The corresponding high side switch must be enabled (HSx bit).

- 1 = PWMIN input controls HSx output.
- 0 = HSx is controlled only by SPI.

**HSx - HSx Switch Control.**

This write-only bit enables/disables the corresponding high side switch.

- 1 = HSx switch on.
- 0 = HSx switch off.

**High Side Status Register - HSSR**

This register returns the status of the high side switches and is also returned when writing to the HSCR.

**Table 20. High Side Status Register - \$6/\$7**

	S3	S2	S1	S0
Read	HS2OP	HS2CL	HS1OP	HS1CL

**High Side Thermal Shutdown**

A thermal shutdown of the high side drivers is indicated by setting all HSxOP and HSxCL bits simultaneously.

**HSxOP - High Side Switch Open-Load Detection**

This read-only bit signals that the high side switches are conducting current below a certain threshold indicating possible load disconnection.

- 1 = HSx Open Load detected (or thermal shutdown)
- 0 = Normal

**HSxCL - High Side Current Limitation**

This read-only bit indicates that the respective high side switch is operating in current limitation mode.

- 1 = HSx in current limitation (or thermal shutdown)
- 0 = Normal

**Low Side Control Register - LSCR**

This register controls the operation of the low side drivers. Writing the Low Side Control Register (LSCR) will also return the Low Side Status Register (LSSR).

**Table 21. Low Side Control Register - \$8**

	C3	C2	C1	C0
Write	PWMLS2	PWMLS1	LS2	LS1
Reset Value	0	0	0	0
Reset Condition	POR		POR, Reset mode, ext_reset, LSx over-temp or (VSOV & HVSE)	

**PWMLx - PWM Input Control Enable.**

This write-only bit enables/disables the PWMIN input pin to control the respective low side switch. The corresponding low side switch must be enabled (LSx bit).

- 1 = PWMIN input controls LSx.
- 0 = LSx is controlled only by SPI.

**LSx - LSx Switch Control.**

This write-only bit enables/disables the corresponding low side switch.

- 1 = LSx switch on.
- 0 = LSx switch off.

**Low Side Status Register - LSSR**

This register returns the status of the low side switches and is also returned when writing to the LSCR.

**Table 22. Low Side Status Register - \$8/\$9**

	C3	C2	C1	C0
Read	LS2OP	LS2CL	LS1OP	LS1CL

**Low Side Thermal Shutdown**

A thermal shutdown of the low side drivers is indicated by setting all LSxOP and LSxCL bits simultaneously.

**LSxOP - Low Side Switch Open-Load Detection**

This read-only bit signals that the low side switches are conducting current below a certain threshold indicating possible load disconnection.

- 1 = LSx Open Load detected (or thermal shutdown)
- 0 = Normal

**LSxCL - Low Side Current Limitation**

This read-only bit indicates that the respective low side switch is operating in current limitation mode.

- 1 = LSx in current limitation (or thermal shutdown)
- 0 = Normal

**Timing Control Register - TIMCR**

This register allows to configure the watchdog, the cyclic sense and Forced Wake-up periods. Writing to the Timing Control Register (TIMCR) will also return the Watchdog Status Register (WDSR).

**Table 23. Timing Control Register - \$A**

	C3	C2	C1	C0
Write	CS/WD	WD2	WD1	WD0
		CYST2	CYST1	CYST0
Reset Value	-	0	0	0
Reset Condition	-	POR		

**CS/WD - Cyclic Sense or Watchdog Prescaler Select**

This write-only bit selects which prescaler is being written to, the Cyclic Sense/Forced Wake-up prescaler or the Watchdog prescaler.

- 1 = Cyclic Sense/Forced Wake-up Prescaler selected
- 0 = Watchdog Prescaler select

**WDx - Watchdog Prescaler**

This write-only bits selects the divider for the watchdog prescaler and therefore selects the watchdog period in accordance with [Table 24](#). This configuration is valid only if windowing watchdog is active.

**Table 24. watchdog Prescaler**

WD2	WD1	WD0	Prescaler Divider
0	0	0	1
0	0	1	2
0	1	0	4
0	1	1	6
1	0	0	8
1	0	1	10
1	1	0	12
1	1	1	14

**CYSTx - Cyclic Sense Period Prescaler Select**

This write-only bits selects the interval for the wake-up cyclic sensing together with the bit CYSX8 in the Configuration Register (CFR) (see page [45](#)).

This option is only active if one of the high side switches is enabled when entering in Stop or Sleep mode. Otherwise, a timed wake-up is performed after the period shown in [Table 25](#).

**Table 25. Cyclic Sense and Force Wake up Interval**

CYSX8 <sup>(71)</sup>	CYST2	CYST1	CYST0	Interval
X	0	0	0	No cyclic sense <sup>(72)</sup>
0	0	0	1	20 ms
0	0	1	0	40 ms
0	0	1	1	60 ms
0	1	0	0	80 ms
0	1	0	1	100 ms
0	1	1	0	120 ms
0	1	1	1	140 ms
1	0	0	1	160 ms
1	0	1	0	320 ms
1	0	1	1	480 ms
1	1	0	0	640 ms
1	1	0	1	800 ms
1	1	1	0	960 ms
1	1	1	1	1120 ms

**Notes**

- 71. bit CYSX8 is located in Configuration Register (CFR)
- 72. No Cyclic Sense and no Force Wake-up available.

**Watchdog Status Register - WDSR**

This register returns the Watchdog status information and is also returned when writing to the TIMCR.

**Table 26. Watchdog Status Register - \$A/\$B**

	S3	S2	S1	S0
Read	WDTO	WDERR	WDOFF	WDWO

**WDTO - Watchdog Timeout**

This read-only bit signals the last reset was caused by either a watchdog timeout or by an attempt to clear the Watchdog within the window closed.

Any access to this register or the Timing Control Register (TIMCR) will clear the WDTO bit.

- 1 = Last reset caused by watchdog timeout
- 0 = None

**WDERR - Watchdog Error**

This read-only bit signals the detection of a missing watchdog resistor. In this condition the watchdog is using the internal, lower precision timebase. The Windowing function is disabled.

- 1 = WDCONF pin resistor missing
- 0 = WDCONF pin resistor not floating

**WDOFF - Watchdog Off**

This read-only bit signals that the watchdog pin connected to Ground and therefore disabled. In this case watchdog timeouts are disabled and the device automatically enters Normal mode out of Reset. This might be necessary for software debugging and for programming the Flash memory.

- 1 = Watchdog is disabled
- 0 = Watchdog is enabled

**WDWO - Watchdog Window Open**

This read-only bit signals when the watchdog window is open for clears. The purpose of this bit is for testing. Should be ignored in case WDERR is High.

- 1 = Watchdog window open
- 0 = Watchdog window closed

**Analog Multiplexer Control Register - MUXCR**

This register controls the analog multiplexer and selects the divider ration for the Lx input divider.

**Table 27. Analog Multiplexer Control Register - \$C**

	C3	C2	C1	C0
Write	LXDS	MX2	MX1	MX0
Reset Value	1	0	0	0
Reset Condition	POR	POR, Reset mode or ext_reset		

**LXDS - Lx Analog Input Divider Select**

This write-only bit selects the resistor divider for the Lx analog inputs. Voltage is internally clamped to VDD.

- 0 = Lx Analog divider: 1
- 1 = Lx Analog divider: 3.6 (typ.)

**MXx - Analog Multiplexer Input Select**

These write-only bits selects which analog input is multiplexed to the ADOUT0 pin according to [Table 28](#).

When disabled or when in Stop or Sleep mode, the output buffer is not powered and the ADOUT0 output is left floating to achieve lower current consumption.

**Table 28. Analog Multiplexer Channel Select**

MX2	MX1	MX0	Meaning
0	0	0	Disabled
0	0	1	Reserved
0	1	0	Die Temperature Sensor
0	1	1	VSENSE input
1	0	0	L1 input
1	0	1	L2 input
1	1	0	L3 input
1	1	1	L4 input

**Configuration Register - CFR**

This register controls the Hall Sensor Supply enable/disable, the cyclic sense timing multiplier, enables/disables the Current Sense Auto-zero function and selects the gain for the current sense amplifier.

**Table 29. Configuration Register - \$D**

	C3	C2	C1	C0
Write	HVDD	CYSX8	CSAZ	CSGS
Reset Value	0	0	0	0
Reset Condition	POR, Reset mode or ext_reset	POR	POR	POR

**HVDD - Hall Sensor Supply Enable**

This write-only bit enables/disables the state of the hall sensor supply.

- 1 = HVDD on
- 0 = HVDD off

**CYSX8 - Cyclic Sense Timing x 8.**

This write-only bit influences the cyclic sense and Forced Wake-up period as shown in [Table 25](#).

- 1 = Multiplier enabled
- 0 = None

**CSAZ - Current Sense Auto-Zero Function Enable**

This write-only bit enables/disables the circuitry to lower the offset voltage of the current sense amplifier.

- 1 = Auto-zero function enabled
- 0 = Auto-zero function disabled

**CSGS - Current Sense Amplifier Gain Select**

This write-only bit selects the gain of the current sense amplifier.

- 1 = 14.5 (typ.)
- 0 = 30 (typ.)

**Interrupt Mask Register - IMR**

This register allows masking of some of the interrupt sources. No interrupt will be generated to the MCU and no flag will be set in the ISR register. The 5.0 V Regulator over-temperature prewarning interrupt and under-voltage (VSUV) interrupts can not be masked and will always cause an interrupt.

Writing to the IMR will return the ISR.

**Table 30. Interrupt Mask Register - \$E**

	C3	C2	C1	C0
Write	HSM	LSM	LINM	VMM
Reset Value	1	1	1	1
Reset Condition	POR			

**HSM - High Side Interrupt Mask**

This write-only bit enables/disables interrupts generated in the high side block.

1 = HS Interrupts Enabled

0 = HS Interrupts Disabled

**LSM - Low Side Interrupt Mask**

This write-only bit enables/disables interrupts generated in the low side block.

1 = LS Interrupts Enabled

0 = LS Interrupts Disabled

**LINM - LIN Interrupts Mask**

This write-only bit enables/disables interrupts generated in the LIN block.

1 = LIN Interrupts Enabled

0 = LIN Interrupts Disabled

**VMM - Voltage Monitor Interrupt Mask**

This write-only bit enables/disables interrupts generated in the Voltage Monitor block. The only maskable interrupt in the Voltage Monitor Block is the V<sub>SUP</sub> over-voltage interrupt.

1 = Interrupts Enabled

0 = Interrupts Disabled

**Interrupt Source Register - ISR**

This register allows the MCU to determine the source of the last interrupt or wake-up respectively. A read of the register acknowledges the interrupt and leads  $\overline{IRQ}$  pin to high, in case there are no other pending interrupts. If there are pending interrupts,  $\overline{IRQ}$  will be driven high for 10  $\mu$ s and then be driven low again.

This register is also returned when writing to the Interrupt Mask Register (IMR).

**Table 31. Interrupt Source Register - \$E/\$F**

	S3	S2	S1	S0
Read	ISR3	ISR2	ISR1	ISR0

**ISR<sub>x</sub> - Interrupt Source Register**

These read-only bits indicate the interrupt source following [Table 32](#). If no interrupt is pending then all bits are 0.

In case more than one interrupt is pending, the interrupt sources are handled sequentially multiplex.

**Table 32. Interrupt Sources**

				Interrupt Source		Priority
ISR3	ISR2	ISR1	ISR0	none maskable	maskable	
0	0	0	0	no interrupt	no interrupt	none
0	0	0	1	Lx Wake-up from Stop and Sleep mode	-	highest
0	0	1	0	-	HS Interrupt (Over-temperature)	
0	0	1	1	-	LS Interrupt (Over-temperature)	
0	1	0	0	LIN Wake-up	LIN Interrupt (RXSHORT, TXDOM, LIN OT)	
0	1	0	1	Voltage Monitor Interrupt (Low Voltage and VDD over-temperature)	Voltage Monitor Interrupt (High Voltage)	
0	1	1	0	Forced Wake-up	-	lowest



**MC33912BAC PRODUCT SPECIFICATIONS  
PAGES 48 TO 90**



**INTERNAL BLOCK DIAGRAM**

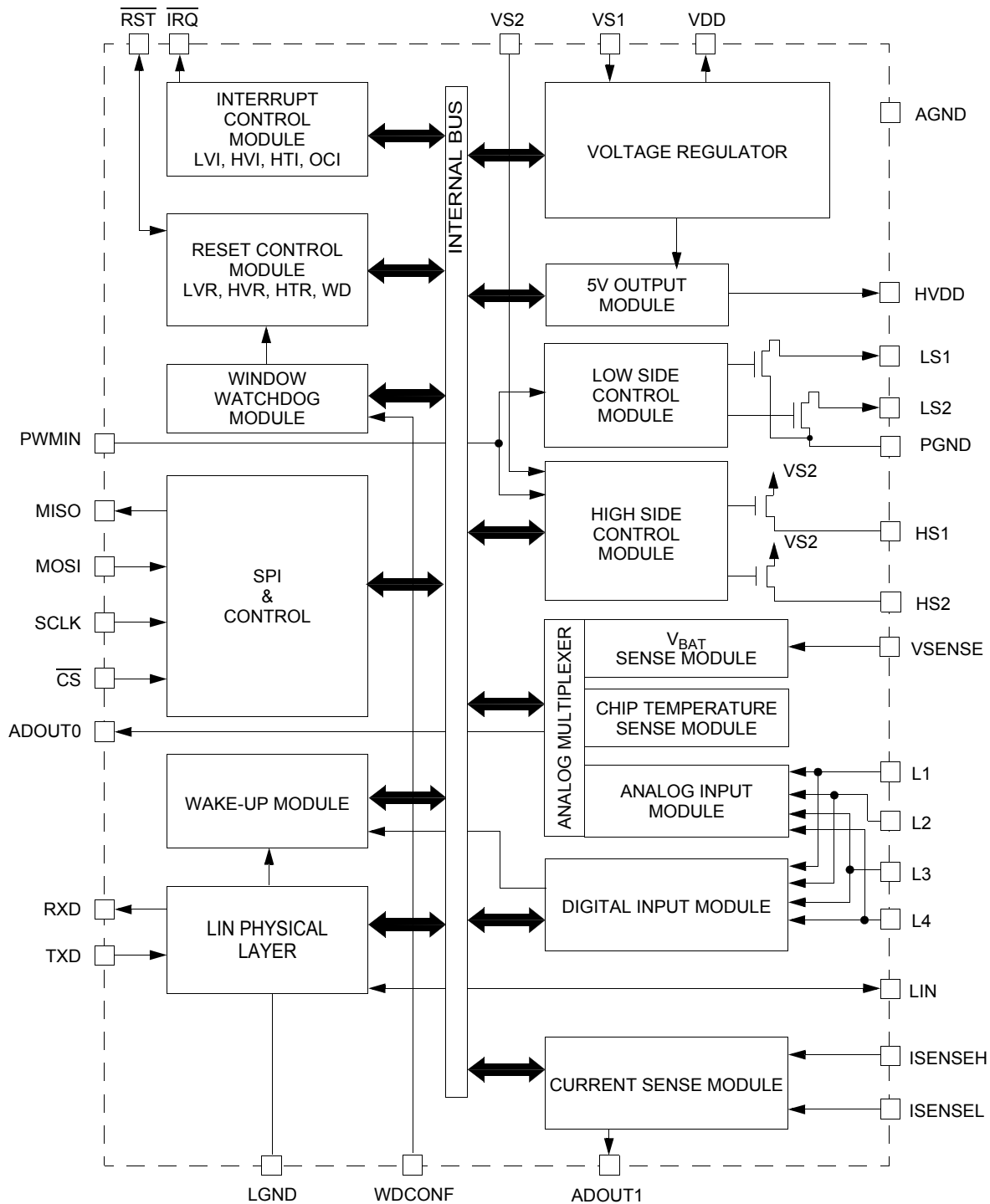

**Figure 25. 33912 Simplified Internal Block Diagram**

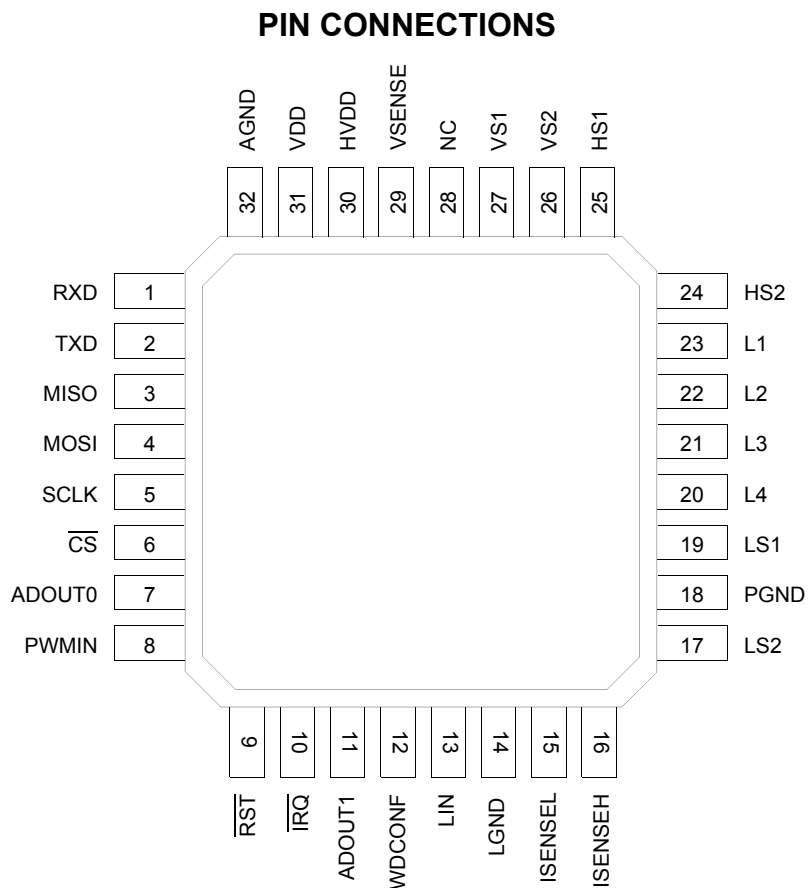

Figure 26. 33912 Pin Connections

Table 33. 33912 Pin Definitions

A functional description of each pin can be found in the [Functional Pin Description on page 68](#).

Pin	Pin Name	Formal Name	Definition
1	RXD	Receiver Output	This pin is the receiver output of the LIN interface which reports the state of the bus voltage to the MCU interface.
2	TXD	Transmitter Input	This pin is the transmitter input of the LIN interface which controls the state of the bus output.
3	MISO	SPI Output	SPI (Serial Peripheral Interface) data output. When $\overline{CS}$ is high, pin is in the high-impedance state.
4	MOSI	SPI Input	SPI (Serial Peripheral Interface) data input.
5	SCLK	SPI Clock	SPI (Serial Peripheral Interface) clock Input.
6	$\overline{CS}$	SPI Chip Select	SPI (Serial Peripheral Interface) chip select input pin. $\overline{CS}$ is active low.
7	ADOUT0	Analog Output Pin 0	Analog Multiplexer Output.
8	PWMIN	PWM Input	High Side and Low Side Pulse Width Modulation Input.
9	$\overline{RST}$	Internal Reset I/O	Bidirectional Reset I/O pin - driven low when any internal reset source is asserted. $\overline{RST}$ is active low.
10	$\overline{IRQ}$	Internal Interrupt Output	Interrupt output pin, indicating wake-up events from Stop mode or events from Normal and Normal request modes. $\overline{IRQ}$ is active low.
11	ADOUT1	Analog Output Pin 1	Current sense analog output.

**Table 33. 33912 Pin Definitions**

A functional description of each pin can be found in the [Functional Pin Description on page 68](#).

Pin	Pin Name	Formal Name	Definition
12	WDCONF	Watchdog Configuration Pin	This input pin is for configuration of the watchdog period and allows the disabling of the watchdog.
13	LIN	LIN Bus	This pin represents the single-wire bus transmitter and receiver.
14	LGND	LIN Ground Pin	This pin is the device LIN ground connection. It is internally connected to the PGND pin.
15	ISENSEL	Current Sense Pins	Current Sense differential inputs.
16	ISENSEH		
17	LS2	Low Side Outputs	Relay drivers low side outputs.
19	LS1		
18	PGND	Power Ground Pin	This pin is the device low side ground connection. It is internally connected to the LGND pin.
20	L4	Wake-up Inputs	These pins are the wake-up capable digital inputs <sup>(73)</sup> . In addition, all Lx inputs can be sensed analog via the analog multiplexer.
21	L3		
22	L2		
23	L1		
24	HS2	High Side Outputs	High side switch outputs.
25	HS1		
26	VS2	Power Supply Pin	These pins are device battery level power supply pins.VS2 is supplying the HSx drivers while VS1 supplies the remaining blocks. <sup>(74)</sup>
27	VS1		
29	VSENSE	Voltage Sense Pin	Battery voltage sense input. <sup>(75)</sup>
30	HVDD	Hall Sensor Supply Output	+5.0 V switchable supply output pin. <sup>(76)</sup>
31	VDD	Voltage Regulator Output	+5.0 V main voltage regulator output pin. <sup>(77)</sup>
32	AGND	Analog Ground Pin	This pin is the device analog ground connection.

**Notes**

73. When used as digital input, a series 33 k $\Omega$  resistor must be used to protect against automotive transients.
74. Reverse battery protection series diodes must be used externally to protect the internal circuitry.
75. This pin can be connected directly to the battery line for voltage measurements. The pin is self protected against reverse battery connections. It is strongly recommended to connect a 10k $\Omega$  resistor in series with this pin for protection purposes.
76. External capacitor (1.0  $\mu$ F < C < 10  $\mu$ F; 0.1  $\Omega$  < ESR < 5.0  $\Omega$ ) required.
77. External capacitor (2.0  $\mu$ F < C < 100  $\mu$ F; 0.1  $\Omega$  < ESR < 10.0  $\Omega$ ) required.

## ELECTRICAL CHARACTERISTICS

## MAXIMUM RATINGS

Table 34. Maximum Ratings

All voltages are with respect to ground unless otherwise noted. Exceeding these ratings may cause a malfunction or permanent damage to the device.

Ratings	Symbol	Value	Unit
<b>ELECTRICAL RATINGS</b>			
Supply Voltage at VS1 and VS2			V
Normal Operation (DC)	$V_{SUP(SS)}$	-0.3 to 27	
Transient Conditions (load dump)	$V_{SUP(PK)}$	-0.3 to 40	
Supply Voltage at VDD	$V_{DD}$	-0.3 to 5.5	V
Input / Output Pins Voltage <sup>(78)</sup>			V
$\overline{CS}$ , $\overline{RST}$ , SCLK, PwMIN, ADOUT0, ADOUT1, MOSI, MISO, TXD, RXD, HVDD	$V_{IN}$	-0.3 to $V_{DD} + 0.3$	
Interrupt Pin ( $\overline{IRQ}$ ) <sup>(79)</sup>	$V_{IN(IRQ)}$	-0.3 to 11	
HS1 and HS2 Pin Voltage (DC)	$V_{HS}$	-0.3 to $V_{SUP} + 0.3$	V
LS1 and LS2 Pin Voltage (DC)	$V_{LS}$	-0.3 to 45	V
L1, L2, L3 and L4 Pin Voltage			V
Normal Operation with a series 33 k resistor (DC)	$V_{LxDC}$	-18 to 40	
Transient input voltage with external component (according to ISO7637-2) (See <a href="#">Figure 28</a> )	$V_{LxTR}$	±100	
ISENSEH and ISENSEL Pin Voltage (DC)	$V_{ISENSE}$	-0.3 to 40	V
VSENSE Pin Voltage (DC)	$V_{VSENSE}$	-27 to 40	V
LIN Pin Voltage			V
Normal Operation (DC)	$V_{BUSDC}$	-18 to 40	
Transient input voltage with external component (according to ISO7637-2) (See <a href="#">Figure 27</a> )	$V_{BUSTR}$	-150 to 100	
VDD output current	$I_{VDD}$	Internally Limited	A
ESD Voltage <sup>(80)</sup>			V
Human Body Model - LIN Pin	$V_{ESD1-1}$	±8000	
Human Body Model - all other Pins	$V_{ESD1-2}$	±2000	
Machine Model	$V_{ESD2}$	±150	
Charge Device Model			
Corner Pins (Pins 1, 8, 9, 16, 17, 24, 25 and 32)	$V_{ESD3-1}$	±750	
All other Pins (Pins 2-7, 10-15, 18-23, 26-31)	$V_{ESD3-2}$	±500	

## Notes

78. Exceeding voltage limits on specified pins may cause a malfunction or permanent damage to the device.  
79. Extended voltage range for programming purpose only.  
80. Testing is performed in accordance with the Human Body Model ( $C_{ZAP} = 100$  pF,  $R_{ZAP} = 1500$  Ω), Machine Model ( $C_{ZAP} = 200$  pF,  $R_{ZAP} = 0$  Ω) and the Charge Device Model, Robotic ( $C_{ZAP} = 4.0$  pF).

**Table 34. Maximum Ratings (continued)**

All voltages are with respect to ground unless otherwise noted. Exceeding these ratings may cause a malfunction or permanent damage to the device.

Ratings	Symbol	Value	Unit
<b>THERMAL RATINGS</b>			
Operating Ambient Temperature <sup>(81)</sup>	$T_A$	-40 to 125	°C
33912 34912		-40 to 85	
Operating Junction Temperature	$T_J$	-40 to 150	°C
Storage Temperature	$T_{STG}$	-55 to 150	°C
Thermal Resistance, Junction to Ambient Natural Convection, Single Layer board (1s) <sup>(82), (83)</sup> Natural Convection, Four Layer board (2s2p) <sup>(82), (84)</sup>	$R_{\theta JA}$	85	°C/W
		56	
Thermal Resistance, Junction to Case <sup>(85)</sup>	$R_{\theta JC}$	23	°C/W
Peak Package Reflow Temperature During Reflow <sup>(86), (87)</sup>	$T_{PPRT}$	Note 87	°C

**Notes**

81. The limiting factor is junction temperature; taking into account the power dissipation, thermal resistance, and heat sinking.
82. Junction temperature is a function of on-chip power dissipation, package thermal resistance, mounting site (board) temperature, ambient temperature, air flow, power dissipation of other components on the board, and board thermal resistance.
83. Per JEDEC JESD51-2 with the single layer board (JESD51-3) horizontal.
84. Per JEDEC JESD51-6 with the board (JESD51-7) horizontal.
85. Thermal resistance between the die and the case top surface as measured by the cold plate method (MIL SPEC-883 Method 1012.1).
86. Pin soldering temperature limit is for 10 seconds maximum duration. Not designed for immersion soldering. Exceeding these limits may cause malfunction or permanent damage to the device.
87. Freescale's Package Reflow capability meets Pb-free requirements for JEDEC standard J-STD-020C. For Peak Package Reflow Temperature and Moisture Sensitivity Levels (MSL), Go to [www.freescale.com](http://www.freescale.com), search by part number [e.g. remove prefixes/suffixes and enter the core ID to view all orderable parts. (i.e. MC33xxx enter 33xxx), and review parametrics.

## STATIC ELECTRICAL CHARACTERISTICS

**Table 35. Static Electrical Characteristics**

Characteristics noted under conditions  $5.5\text{ V} \leq V_{\text{SUP}} \leq 18\text{ V}$ ,  $-40^\circ\text{C} \leq T_{\text{A}} \leq 125^\circ\text{C}$  for the 33912 and  $-40^\circ\text{C} \leq T_{\text{A}} \leq 85^\circ\text{C}$  for the 34912, unless otherwise noted. Typical values noted reflect the approximate parameter mean at  $T_{\text{A}} = 25^\circ\text{C}$  under nominal conditions, unless otherwise noted.

Characteristic	Symbol	Min	Typ	Max	Unit
<b>SUPPLY VOLTAGE RANGE (VS1, VS2)</b>					
Nominal Operating Voltage	$V_{\text{SUP}}$	5.5	–	18	V
Functional Operating Voltage <sup>(88)</sup>	$V_{\text{SUPOP}}$	–	–	27	V
Load Dump	$V_{\text{SUPLD}}$	–	–	40	V
<b>SUPPLY CURRENT RANGE (<math>V_{\text{SUP}} = 13.5\text{ V}</math>)</b>					
Normal Mode ( $I_{\text{OUT}}$ at $V_{\text{DD}} = 10\text{ mA}$ ), LIN Recessive State <sup>(89)</sup>	$I_{\text{RUN}}$	–	4.5	10	mA
Stop mode, VDD ON with $I_{\text{OUT}} = 100\text{ }\mu\text{A}$ , LIN Recessive State <sup>(89), (90), (91)</sup>	$I_{\text{STOP}}$	–	48	80	$\mu\text{A}$
		–	58	90	
Sleep mode, VDD OFF, LIN Recessive State <sup>(89), (91)</sup>	$I_{\text{SLEEP}}$	–	27	35	$\mu\text{A}$
		–	37	48	
Cyclic Sense Supply Current Adder <sup>(92)</sup>	$I_{\text{CYCLIC}}$	–	10	–	$\mu\text{A}$
<b>SUPPLY UNDER/OVER-VOLTAGE DETECTIONS</b>					
Power-On Reset (BATFAIL) <sup>(93)</sup>					V
Threshold (measured on VS1) <sup>(92)</sup>	$V_{\text{BATFAIL}}$	1.5	3.0	3.9	
Hysteresis (measured on VS1) <sup>(92)</sup>	$V_{\text{BATFAIL\_HYS}}$	–	0.9	–	
$V_{\text{SUP}}$ Under-voltage Detection (VSUV Flag) (Normal and Normal Request modes, Interrupt Generated)					V
Threshold (measured on VS1)	$V_{\text{SUV}}$	5.55	6.0	6.6	
Hysteresis (measured on VS1)	$V_{\text{SUV\_HYS}}$	–	1.0	–	
$V_{\text{SUP}}$ Over-voltage Detection (VSOV Flag) (Normal and Normal Request modes, Interrupt Generated)					V
Threshold (measured on VS1)	$V_{\text{SOV}}$	18	19.25	20.5	
Hysteresis (measured on VS1)	$V_{\text{SOV\_HYS}}$	–	1.0	–	

## Notes

88. Device is fully functional. All features are operating.
89. Total current ( $I_{\text{VS1}} + I_{\text{VS2}}$ ) measured at GND pins excluding all loads, cyclic sense disabled.
90. Total  $I_{\text{DD}}$  current (including loads) below  $100\text{ }\mu\text{A}$ .
91. Stop and Sleep modes current will increase if  $V_{\text{SUP}}$  exceeds  $13.5\text{ V}$ .
92. This parameter is guaranteed by process monitoring but not production tested.
93. The Flag is set during power up sequence. To clear the flag, a SPI read must be performed.

**Table 35. Static Electrical Characteristics (continued)**

Characteristics noted under conditions  $5.5\text{ V} \leq V_{\text{SUP}} \leq 18\text{ V}$ ,  $-40^\circ\text{C} \leq T_{\text{A}} \leq 125^\circ\text{C}$  for the 33912 and  $-40^\circ\text{C} \leq T_{\text{A}} \leq 85^\circ\text{C}$  for the 34912, unless otherwise noted. Typical values noted reflect the approximate parameter mean at  $T_{\text{A}} = 25^\circ\text{C}$  under nominal conditions, unless otherwise noted.

Characteristic	Symbol	Min	Typ	Max	Unit
<b>VOLTAGE REGULATOR<sup>(94)</sup> (VDD)</b>					
Normal Mode Output Voltage $1.0\text{ mA} < I_{\text{VDD}} < 50\text{ mA}$ ; $5.5\text{ V} < V_{\text{SUP}} < 27\text{ V}$	$V_{\text{DDRUN}}$	4.75	5.00	5.25	V
Normal Mode Output Current Limitation	$I_{\text{VDDRUN}}$	60	110	200	mA
Dropout Voltage <sup>(95)</sup> $I_{\text{VDD}} = 50\text{ mA}$	$V_{\text{DDDROP}}$	–	0.1	0.25	V
Stop Mode Output Voltage $I_{\text{VDD}} < 5.0\text{ mA}$	$V_{\text{DDSTOP}}$	4.75	5.0	5.25	V
Stop Mode Output Current Limitation	$I_{\text{VDDSTOP}}$	6.0	12	36	mA
Line Regulation Normal mode, $5.5\text{ V} < V_{\text{SUP}} < 18\text{ V}$ ; $I_{\text{VDD}} = 10\text{ mA}$ Stop mode, $5.5\text{ V} < V_{\text{SUP}} < 18\text{ V}$ ; $I_{\text{VDD}} = 1.0\text{ mA}$	$LR_{\text{RUN}}$ $LR_{\text{STOP}}$	– –	20 5.0	25 25	mV
Load Regulation Normal mode, $1.0\text{ mA} < I_{\text{VDD}} < 50\text{ mA}$ Stop mode, $0.1\text{ mA} < I_{\text{VDD}} < 5.0\text{ mA}$	$LD_{\text{RUN}}$ $LD_{\text{STOP}}$	– –	15 10	80 50	mV
Over-temperature Prewarning (Junction) <sup>(96)</sup> Interrupt generated, VDDOT Bit Set	$T_{\text{PRE}}$	110	125	140	$^\circ\text{C}$
Over-temperature Prewarning Hysteresis <sup>(96)</sup>	$T_{\text{PRE\_HYS}}$	–	10	–	$^\circ\text{C}$
Over-temperature Shutdown Temperature (Junction) <sup>(96)</sup>	$T_{\text{SD}}$	155	170	185	$^\circ\text{C}$
Over-temperature Shutdown Hysteresis <sup>(96)</sup>	$T_{\text{SD\_HYS}}$	–	10	–	$^\circ\text{C}$
<b>HALL SENSOR SUPPLY OUTPUT<sup>(97)</sup> (HVDD)</b>					
$V_{\text{DD}}$ Voltage matching $H_{\text{VDDACC}} = (HVDD - VDD) / VDD * 100\%$ $I_{\text{HVDD}} = 15\text{ mA}$	$H_{\text{VDDACC}}$	-2.0	–	2.0	%
Current Limitation	$I_{\text{HVDD}}$	20	30	50	mA
Dropout Voltage $I_{\text{HVDD}} = 15\text{ mA}$ ; $I_{\text{VDD}} = 5.0\text{ mA}$	$H_{\text{VDDDROP}}$	–	160	300	mV
Line Regulation $I_{\text{HVDD}} = 5.0\text{ mA}$ ; $I_{\text{VDD}} = 5.0\text{ mA}$	$LR_{\text{HVDD}}$	–	25	40	mV
Load Regulation $1.0\text{ mA} > I_{\text{HVDD}} > 15\text{ mA}$ ; $I_{\text{VDD}} = 5.0\text{ mA}$	$LD_{\text{HVDD}}$	–	10	20	mV

## Notes

94. Specification with external capacitor  $2.0\text{ }\mu\text{F} < C < 100\text{ }\mu\text{F}$  and  $100\text{ m}\Omega \leq \text{ESR} \leq 10\text{ }\Omega$ .  
 95. Measured when voltage has dropped 250 mV below its nominal Value (5.0 V).  
 96. This parameter is guaranteed by process monitoring but not production tested.  
 97. Specification with external capacitor  $1.0\text{ }\mu\text{F} < C < 10\text{ }\mu\text{F}$  and  $100\text{ m}\Omega \leq \text{ESR} \leq 10\text{ }\Omega$ .

ELECTRICAL CHARACTERISTICS  
STATIC ELECTRICAL CHARACTERISTICS**Table 35. Static Electrical Characteristics (continued)**

Characteristics noted under conditions  $5.5\text{ V} \leq V_{\text{SUP}} \leq 18\text{ V}$ ,  $-40^\circ\text{C} \leq T_{\text{A}} \leq 125^\circ\text{C}$  for the 33912 and  $-40^\circ\text{C} \leq T_{\text{A}} \leq 85^\circ\text{C}$  for the 34912, unless otherwise noted. Typical values noted reflect the approximate parameter mean at  $T_{\text{A}} = 25^\circ\text{C}$  under nominal conditions, unless otherwise noted.

Characteristic	Symbol	Min	Typ	Max	Unit
<b>RST INPUT/OUTPUT PIN (<math>\overline{\text{RST}}</math>)</b>					
VDD Low Voltage Reset Threshold	$V_{\overline{\text{RST}}\text{TH}}$	4.3	4.5	4.7	V
Low-state Output Voltage $I_{\text{OUT}} = 1.5\text{ mA}$ ; $3.5\text{ V} \leq V_{\text{SUP}} \leq 27\text{ V}$	$V_{\text{OL}}$	0.0	–	0.9	V
High-state Output Current ( $0 < V_{\text{OUT}} < 3.5\text{ V}$ )	$I_{\text{OH}}$	-150	-250	-350	$\mu\text{A}$
Pull-down Current Limitation (internally limited) $V_{\text{OUT}} = V_{\text{DD}}$	$I_{\text{PD\_MAX}}$	1.5	–	8.0	mA
Low-state Input Voltage	$V_{\text{IL}}$	-0.3	–	$0.3 \times V_{\text{DD}}$	V
High-state Input Voltage	$V_{\text{IH}}$	$0.7 \times V_{\text{DD}}$	–	$V_{\text{DD}} + 0.3$	V
<b>MISO SPI OUTPUT PIN (MISO)</b>					
Low-state Output Voltage $I_{\text{OUT}} = 1.5\text{ mA}$	$V_{\text{OL}}$	0.0	–	1.0	V
High-state Output Voltage $I_{\text{OUT}} = -250\ \mu\text{A}$	$V_{\text{OH}}$	$V_{\text{DD}} - 0.9$	–	$V_{\text{DD}}$	V
Tri-state Leakage Current $0\text{ V} \leq V_{\text{MISO}} \leq V_{\text{DD}}$	$I_{\text{TRIMISO}}$	-10	–	10	$\mu\text{A}$
<b>SPI INPUT PINS (MOSI, SCLK, <math>\overline{\text{CS}}</math>)</b>					
Low-state Input Voltage	$V_{\text{IL}}$	-0.3	–	$0.3 \times V_{\text{DD}}$	V
High-state Input Voltage	$V_{\text{IH}}$	$0.7 \times V_{\text{DD}}$	–	$V_{\text{DD}} + 0.3$	V
MOSI, SCLK Input Current $0\text{ V} \leq V_{\text{IN}} \leq V_{\text{DD}}$	$I_{\text{IN}}$	-10	–	10	$\mu\text{A}$
$\overline{\text{CS}}$ Pull-up Current $0\text{ V} < V_{\text{IN}} < 3.5\text{ V}$	$I_{\text{PUCS}}$	10	20	30	$\mu\text{A}$
<b>INTERRUPT OUTPUT PIN (<math>\overline{\text{IRQ}}</math>)</b>					
Low-state Output Voltage $I_{\text{OUT}} = 1.5\text{ mA}$	$V_{\text{OL}}$	0.0	–	0.8	V
High-state Output Voltage $I_{\text{OUT}} = -250\ \mu\text{A}$	$V_{\text{OH}}$	$V_{\text{DD}} - 0.8$	–	$V_{\text{DD}}$	V
Leakage Current $V_{\text{DD}} \leq V_{\text{OUT}} \leq 10\text{ V}$	$V_{\text{OH}}$	–	–	2.0	mA
<b>PULSE WIDTH MODULATION INPUT PIN (PWMIN)</b>					
Low-state Input Voltage	$V_{\text{IL}}$	-0.3	–	$0.3 \times V_{\text{DD}}$	V
High-state Input Voltage	$V_{\text{IH}}$	$0.7 \times V_{\text{DD}}$	–	$V_{\text{DD}} + 0.3$	V
Pull-up current $0\text{ V} < V_{\text{IN}} < 3.5\text{ V}$	$I_{\text{PUPWMIN}}$	10	20	30	$\mu\text{A}$



**Table 35. Static Electrical Characteristics (continued)**

Characteristics noted under conditions  $5.5\text{ V} \leq V_{\text{SUP}} \leq 18\text{ V}$ ,  $-40^\circ\text{C} \leq T_A \leq 125^\circ\text{C}$  for the 33912 and  $-40^\circ\text{C} \leq T_A \leq 85^\circ\text{C}$  for the 34912, unless otherwise noted. Typical values noted reflect the approximate parameter mean at  $T_A = 25^\circ\text{C}$  under nominal conditions, unless otherwise noted.

Characteristic	Symbol	Min	Typ	Max	Unit
<b>HIGH SIDE OUTPUTS HS1 AND HS2 PINS (HS1, HS2)</b>					
Output Drain-to-Source On Resistance $T_J = 25^\circ\text{C}$ , $I_{\text{LOAD}} = 50\text{ mA}$ ; $V_{\text{SUP}} > 9.0\text{ V}$ $T_J = 150^\circ\text{C}$ , $I_{\text{LOAD}} = 50\text{ mA}$ ; $V_{\text{SUP}} > 9.0\text{ V}$ <sup>(98)</sup> $T_J = 150^\circ\text{C}$ , $I_{\text{LOAD}} = 30\text{ mA}$ ; $5.5\text{ V} < V_{\text{SUP}} < 9.0\text{ V}$ <sup>(98)</sup>	$R_{\text{DS(ON)}}$	–	–	7.0 10 14	$\Omega$
Output Current Limitation <sup>(99)</sup> $0\text{ V} < V_{\text{OUT}} < V_{\text{SUP}} - 2.0\text{ V}$	$I_{\text{LIMHSX}}$	60	120	250	mA
Open Load Current Detection <sup>(100)</sup>	$I_{\text{OLHSX}}$	–	5.0	7.5	mA
Leakage Current $-0.2\text{ V} < V_{\text{HSX}} < V_{\text{S2}} + 0.2\text{ V}$	$I_{\text{LEAK}}$	–	–	10	$\mu\text{A}$
Short-circuit Detection Threshold <sup>(101)</sup> $5.5\text{ V} < V_{\text{SUP}} < 27\text{ V}$	$V_{\text{THSC}}$	$V_{\text{SUP}} - 2.0$	–	–	V
Over-temperature Shutdown <sup>(102), (107)</sup>	$T_{\text{HSSD}}$	150	165	180	$^\circ\text{C}$
Over-temperature Shutdown Hysteresis <sup>(107)</sup>	$T_{\text{HSSD\_HYS}}$	–	10	–	$^\circ\text{C}$
<b>LOW SIDE OUTPUTS LS1 AND LS2 PINS (LS1, LS2)</b>					
Output Drain-to-Source On Resistance $T_J = 25^\circ\text{C}$ , $I_{\text{LOAD}} = 150\text{ mA}$ , $V_{\text{SUP}} > 9.0\text{ V}$ $T_J = 125^\circ\text{C}$ , $I_{\text{LOAD}} = 150\text{ mA}$ , $V_{\text{SUP}} > 9.0\text{ V}$ $T_J = 125^\circ\text{C}$ , $I_{\text{LOAD}} = 120\text{ mA}$ , $5.5\text{ V} < V_{\text{SUP}} < 9.0\text{ V}$	$R_{\text{DS(ON)}}$	–	–	2.5 4.5 10	$\Omega$
Output Current Limitation <sup>(103)</sup> $2.0\text{ V} < V_{\text{OUT}} < V_{\text{SUP}}$	$I_{\text{LIMLSX}}$	160	275	350	mA
Open Load Current Detection <sup>(104)</sup>	$I_{\text{OLLSX}}$	–	8.0	12	mA
Leakage Current $-0.2\text{ V} < V_{\text{OUT}} < V_{\text{S1}}$	$I_{\text{LEAK}}$	–	–	10	$\mu\text{A}$
Active Output Energy Clamp $I_{\text{OUT}} = 150\text{ mA}$	$V_{\text{CLAMP}}$	$V_{\text{SUP}} + 2.0$	–	$V_{\text{SUP}} + 5.0$	V
Short-circuit Detection Threshold <sup>(105)</sup> $5.5\text{ V} < V_{\text{SUP}} < 27\text{ V}$	$V_{\text{THSC}}$	2.0	–	–	V
Over-temperature Shutdown <sup>(106), (107)</sup>	$T_{\text{LSSD}}$	150	165	180	$^\circ\text{C}$
Over-temperature Shutdown Hysteresis <sup>(107)</sup>	$T_{\text{LSSD\_HYS}}$	–	10	–	$^\circ\text{C}$

## Notes

98. This parameter is production tested up to  $T_A = 125^\circ\text{C}$  and guaranteed by process monitoring up to  $T_J = 150^\circ\text{C}$ .
99. When over-current occurs, the corresponding high side stays ON with limited current capability and the HSxCL flag is set in the HSSR.
100. When open load occurs, the flag (HSxOP) is set in the HSSR.
101. When short-circuit occurs and if HVSE flag is enabled, both HS automatic shutdown.
102. When over-temperature shutdown occurs, both high sides are turned off. All flags in HSSR are set.
103. When over-current occurs, the corresponding low side stays ON with limited current capability and the LSxCL flag is set in the LSSR.
104. When open load occurs, the flag (LSxOP) is set in the LSSR.
105. When short-circuit occurs and if HVSE Flag is enabled, both LS automatic shutdown.
106. When over-temperature shutdown occurs, both low sides are turned off. All flags in LSSR are set.
107. Guaranteed by characterization but not production tested

ELECTRICAL CHARACTERISTICS  
STATIC ELECTRICAL CHARACTERISTICS**Table 35. Static Electrical Characteristics (continued)**

Characteristics noted under conditions  $5.5\text{ V} \leq V_{\text{SUP}} \leq 18\text{ V}$ ,  $-40^\circ\text{C} \leq T_A \leq 125^\circ\text{C}$  for the 33912 and  $-40^\circ\text{C} \leq T_A \leq 85^\circ\text{C}$  for the 34912, unless otherwise noted. Typical values noted reflect the approximate parameter mean at  $T_A = 25^\circ\text{C}$  under nominal conditions, unless otherwise noted.

Characteristic	Symbol	Min	Typ	Max	Unit
<b>L1, L2, L3 AND L4 INPUT PINS (L1, L2, L3, L4)</b>					
Low Detection Threshold $5.5\text{ V} < V_{\text{SUP}} < 27\text{ V}$	$V_{\text{THL}}$	2.0	2.5	3.0	V
High Detection Threshold $5.5\text{ V} < V_{\text{SUP}} < 27\text{ V}$	$V_{\text{THH}}$	3.0	3.5	4.0	V
Hysteresis $5.5\text{ V} < V_{\text{SUP}} < 27\text{ V}$	$V_{\text{HYS}}$	0.5	1.0	1.5	V
Input Current <sup>(108)</sup> $-0.2\text{ V} < V_{\text{IN}} < V_{\text{S1}}$	$I_{\text{IN}}$	-10	–	10	$\mu\text{A}$
Analog Input Impedance <sup>(109)</sup>	$R_{\text{LXIN}}$	800	1550	–	$\text{k}\Omega$
Analog Input Divider Ratio ( $\text{RATIO}_{\text{LX}} = V_{\text{LX}} / V_{\text{ADOUT0}}$ ) LXDS (Lx Divider Select) = 0 LXDS (Lx Divider Select) = 1	$\text{RATIO}_{\text{LX}}$	0.95 3.42	1.0 3.6	1.05 3.78	
Analog Output offset Ratio LXDS (Lx Divider Select) = 0 LXDS (Lx Divider Select) = 1	$V_{\text{RATIO}_{\text{LX}}\text{-OFFSET}}$	-80 -22	0.0 0.0	80 22	mV
Analog Inputs Matching LXDS (Lx Divider Select) = 0 LXDS (Lx Divider Select) = 1	$\text{LX}_{\text{MATCHING}}$	96 96	100 100	104 104	%

**WINDOW WATCHDOG CONFIGURATION PIN (WDCONF)**

External Resistor Range	$R_{\text{EXT}}$	20	–	200	$\text{k}\Omega$
Watchdog Period Accuracy with External Resistor (Excluding Resistor Accuracy) <sup>(110)</sup>	$\text{WD}_{\text{ACC}}$	-15	–	15	%

**ANALOG MULTIPLEXER**

Internal Chip Temperature Sense Gain	$S_{\text{TTOV}}$	–	10.5	–	mV/K
VSENSE Input Divider Ratio ( $\text{RATIO}_{\text{VSENSE}} = V_{\text{VSENSE}} / V_{\text{ADOUT0}}$ ) $5.5\text{ V} < V_{\text{SUP}} < 27\text{ V}$	$\text{RATIO}_{\text{VSENSE}}$	5.0	5.25	5.5	
VSENSE Output Related Offset $-40^\circ\text{C} < T_A < -20^\circ\text{C}$	$\text{OFFSET}_{\text{VSENSE}}$	-30 -45	– –	30 45	mV

**ANALOG OUTPUTS (ADOUT0 AND ADOUT1)**

Maximum Output Voltage $-5.0\text{ mA} < I_{\text{O}} < 5.0\text{ mA}$	$V_{\text{OUT\_MAX}}$	$V_{\text{DD}} - 0.35$	–	$V_{\text{DD}}$	V
Minimum Output Voltage $-5.0\text{ mA} < I_{\text{O}} < 5.0\text{ mA}$	$V_{\text{OUT\_MIN}}$	0.0	–	0.35	V

## Notes

108. Analog multiplexer input disconnected from Lx input pin.

109. Analog multiplexer input connected to Lx input pin.

110. Watchdog timing period calculation formula:  $t_{\text{PWD}} [\text{ms}] = 0.466 * (R_{\text{EXT}} - 20) + 10$  ( $R_{\text{EXT}}$  in  $\text{k}\Omega$ )

**Table 35. Static Electrical Characteristics (continued)**

Characteristics noted under conditions  $5.5\text{ V} \leq V_{\text{SUP}} \leq 18\text{ V}$ ,  $-40^\circ\text{C} \leq T_A \leq 125^\circ\text{C}$  for the 33912 and  $-40^\circ\text{C} \leq T_A \leq 85^\circ\text{C}$  for the 34912, unless otherwise noted. Typical values noted reflect the approximate parameter mean at  $T_A = 25^\circ\text{C}$  under nominal conditions, unless otherwise noted.

Characteristic	Symbol	Min	Typ	Max	Unit
<b>CURRENT SENSE AMPLIFIER (ISENSEH, ISENSEL)</b>					
Gain	G				
CSGS (Current Sense Gain Select) = 0		29	30	31	
CSGS (Current Sense Gain Select) = 1		14	14.5	15	
Differential Input Impedance	DIFF				k $\Omega$
CSGS (Current Sense Gain Select) = 0		2.0	10	30	
CSGS (Current Sense Gain Select) = 1		5.0	20	50	
Common Mode Input Impedance	CM				k $\Omega$
CSGS (Current Sense Gain Select) = 0		75	–	300	
CSGS (Current Sense Gain Select) = 1		75	–	300	
ISENSEH, ISENSEL Input Voltage Range	$V_{\text{IN}}$	-0.2	–	3.0	V
Input Offset Voltage	$V_{\text{IN\_OFFSET}}$				mV
CSAZ (Current Sense Auto Zero) = 0		-15	–	15	
CSAZ (Current Sense Auto Zero) = 1		-2.0	–	2.0	
<b>RXD OUTPUT PIN (LIN PHYSICAL LAYER) (RXD)</b>					
Low-state Output Voltage	$V_{\text{OL}}$				V
$I_{\text{OUT}} = 1.5\text{ mA}$		0.0	–	0.8	
High-state Output Voltage	$V_{\text{OH}}$				V
$I_{\text{OUT}} = -250\text{ }\mu\text{A}$		$V_{\text{DD}} - 0.8$	–	$V_{\text{DD}}$	
<b>TXD INPUT PIN (LIN PHYSICAL LAYER) (TXD)</b>					
Low-state Input Voltage	$V_{\text{IL}}$	-0.3	–	$0.3 \times V_{\text{DD}}$	V
High-state Input Voltage	$V_{\text{IH}}$	$0.7 \times V_{\text{DD}}$	–	$V_{\text{DD}} + 0.3$	V
Pin Pull-up Current, $0\text{ V} < V_{\text{IN}} < 3.5\text{ V}$	$I_{\text{PUIN}}$	10	20	30	$\mu\text{A}$

ELECTRICAL CHARACTERISTICS  
STATIC ELECTRICAL CHARACTERISTICS**Table 35. Static Electrical Characteristics (continued)**

Characteristics noted under conditions  $5.5\text{ V} \leq V_{\text{SUP}} \leq 18\text{ V}$ ,  $-40^\circ\text{C} \leq T_{\text{A}} \leq 125^\circ\text{C}$  for the 33912 and  $-40^\circ\text{C} \leq T_{\text{A}} \leq 85^\circ\text{C}$  for the 34912, unless otherwise noted. Typical values noted reflect the approximate parameter mean at  $T_{\text{A}} = 25^\circ\text{C}$  under nominal conditions, unless otherwise noted.

Characteristic	Symbol	Min	Typ	Max	Unit
<b>LIN PHYSICAL LAYER, TRANSCEIVER (LIN)<sup>(111)</sup></b>					
Output Current Limitation Dominant State, $V_{\text{BUS}} = 18\text{ V}$	$I_{\text{BUSLIM}}$	40	120	200	mA
Leakage Output Current to GND Dominant State; $V_{\text{BUS}} = 0\text{ V}$ ; $V_{\text{BAT}} = 12\text{ V}$	$I_{\text{BUS\_PAS\_dom}}$	-1.0	–	–	mA
Recessive State; $8.0\text{ V} < V_{\text{BAT}} < 18\text{ V}$ ; $8.0\text{ V} < V_{\text{BUS}} < 18\text{ V}$ ; $V_{\text{BUS}} \geq V_{\text{BAT}}$	$I_{\text{BUS\_PAS\_REC}}$	–	–	20	$\mu\text{A}$
GND Disconnected; $\text{GND}_{\text{DEVICE}} = V_{\text{SUP}}$ ; $V_{\text{BAT}} = 12\text{ V}$ ; $0 < V_{\text{BUS}} < 18\text{ V}$	$I_{\text{BUS\_NO\_GND}}$	-1.0	–	1.0	mA
$V_{\text{BAT}}$ Disconnected; $V_{\text{SUP\_DEVICE}} = \text{GND}$ ; $0 < V_{\text{BUS}} < 18\text{ V}$	$I_{\text{BUS}}$	–	–	100	$\mu\text{A}$
Receiver Input Voltages Receiver Dominant State	$V_{\text{BUSDOM}}$	–	–	0.4	$V_{\text{SUP}}$
Receiver Recessive State	$V_{\text{BUSREC}}$	0.6	–	–	
Receiver Threshold Center $(V_{\text{TH\_DOM}} + V_{\text{TH\_REC}})/2$	$V_{\text{BUS\_CNT}}$	0.475	0.5	0.525	
Receiver Threshold Hysteresis $(V_{\text{TH\_REC}} - V_{\text{TH\_DOM}})$	$V_{\text{HYS}}$	–	–	0.175	
LIN Transceiver Output Voltage Recessive State, TXD HIGH, $I_{\text{OUT}} = 1.0\ \mu\text{A}$	$V_{\text{LIN\_REC}}$	$V_{\text{SUP}} - 1.0$	–	–	V
Dominant State, TXD LOW, 500 $\Omega$ External Pull-up Resistor, LDVS = 0	$V_{\text{LIN\_DOM\_0}}$	–	1.1	1.4	
Dominant State, TXD LOW, 500 $\Omega$ External Pull-up Resistor, LDVS = 1	$V_{\text{LIN\_DOM\_1}}$	–	1.7	2	
LIN Pull-up Resistor to $V_{\text{SUP}}$	$R_{\text{SLAVE}}$	20	30	60	k $\Omega$
Over-temperature Shutdown <sup>(112)</sup>	$T_{\text{LINS D}}$	150	165	180	$^\circ\text{C}$
Over-temperature Shutdown Hysteresis	$T_{\text{LINS D\_HYS}}$	–	10	–	$^\circ\text{C}$

## Notes

111. Parameters guaranteed for  $7.0\text{ V} \leq V_{\text{SUP}} \leq 18\text{ V}$ .

112. When over-temperature shutdown occurs, the LIN bus goes in recessive state and the flag LINOT in LINSR is set.

**DYNAMIC ELECTRICAL CHARACTERISTICS****Table 36. Dynamic Electrical Characteristics**

Characteristics noted under conditions  $5.5\text{ V} \leq V_{\text{SUP}} \leq 18\text{ V}$ ,  $-40^\circ\text{C} \leq T_A \leq 125^\circ\text{C}$  for the 33912 and  $-40^\circ\text{C} \leq T_A \leq 85^\circ\text{C}$  for the 34912, unless otherwise noted. Typical values noted reflect the approximate parameter mean at  $T_A = 25^\circ\text{C}$  under nominal conditions, unless otherwise noted.

Characteristic	Symbol	Min	Typ	Max	Unit
<b>SPI INTERFACE TIMING (SEE Figure 36)</b>					
SPI Operating Frequency	$f_{\text{SPIOP}}$	–	–	4.0	MHz
SCLK Clock Period	$t_{\text{PSCLK}}$	250	–	N/A	ns
SCLK Clock High Time <sup>(113)</sup>	$t_{\text{WSCLKH}}$	110	–	N/A	ns
SCLK Clock Low Time <sup>(113)</sup>	$t_{\text{WSCLKL}}$	110	–	N/A	ns
Falling Edge of $\overline{\text{CS}}$ to Rising Edge of SCLK <sup>(113)</sup>	$t_{\text{LEAD}}$	100	–	N/A	ns
Falling Edge of SCLK to $\overline{\text{CS}}$ Rising Edge <sup>(113)</sup>	$t_{\text{LAG}}$	100	–	N/A	ns
MOSI to Falling Edge of SCLK <sup>(113)</sup>	$t_{\text{SISU}}$	40	–	N/A	ns
Falling Edge of SCLK to MOSI <sup>(113)</sup>	$t_{\text{SIH}}$	40	–	N/A	ns
MISO Rise Time <sup>(113)</sup> $C_L = 220\text{ pF}$	$t_{\text{RSO}}$	–	40	–	ns
MISO Fall Time <sup>(113)</sup> $C_L = 220\text{ pF}$	$t_{\text{FSO}}$	–	40	–	ns
Time from Falling or Rising Edges of $\overline{\text{CS}}$ to: <sup>(113)</sup> - MISO Low-impedance - MISO High-impedance	$t_{\text{SOEN}}$ $t_{\text{SODIS}}$	0.0 0.0	– –	50 50	ns
Time from Rising Edge of SCLK to MISO Data Valid <sup>(113)</sup> $0.2 \times V_{\text{DD}} \leq \text{MISO} \leq 0.8 \times V_{\text{DD}}$ , $C_L = 100\text{ pF}$	$t_{\text{VALID}}$	0.0	–	75	ns
<b>RST OUTPUT PIN</b>					
Reset Low-level Duration After $V_{\text{DD}}$ High (see Figure 35)	$t_{\text{RST}}$	0.65	1.0	1.35	ms
Reset Deglitch Filter Time	$t_{\text{RSTDF}}$	350	600	900	ns
<b>WINDOW WATCHDOG CONFIGURATION PIN (WDCONF)</b>					
Watchdog Time Period <sup>(114)</sup> External Resistor $R_{\text{EXT}} = 20\text{ k}\Omega$ (1%) External Resistor $R_{\text{EXT}} = 200\text{ k}\Omega$ (1%) Without External Resistor $R_{\text{EXT}}$ (WDCONF Pin Open)	$t_{\text{PWD}}$	8.5 79 110	10 94 150	11.5 108 205	ms
<b>CURRENT SENSE AMPLIFIER<sup>(113)</sup></b>					
Common Mode Rejection Ratio	CMR	70	–	–	dB
Supply Voltage Rejection Ratio <sup>(115)</sup>	SVR	60	–	–	dB
Gain Bandwidth Product	GBP	0.75	3.0	–	MHz
Output Slew-rate	SR	0.5	–	–	V/ $\mu\text{s}$

**Notes**

113. This parameter is guaranteed by process monitoring but not production tested.  
 114. Watchdog timing period calculation formula:  $t_{\text{PWD}} [\text{ms}] = 0.466 * (R_{\text{EXT}} - 20) + 10$  ( $R_{\text{EXT}}$  in  $\text{k}\Omega$ )  
 115. Analog Outputs are supplied by  $V_{\text{DD}}$

ELECTRICAL CHARACTERISTICS  
DYNAMIC ELECTRICAL CHARACTERISTICS**Table 36. Dynamic Electrical Characteristics (continued)**

Characteristics noted under conditions  $5.5\text{ V} \leq V_{\text{SUP}} \leq 18\text{ V}$ ,  $-40^\circ\text{C} \leq T_{\text{A}} \leq 125^\circ\text{C}$  for the 33912 and  $-40^\circ\text{C} \leq T_{\text{A}} \leq 85^\circ\text{C}$  for the 34912, unless otherwise noted. Typical values noted reflect the approximate parameter mean at  $T_{\text{A}} = 25^\circ\text{C}$  under nominal conditions, unless otherwise noted.

Characteristic	Symbol	Min	Typ	Max	Unit
<b>L1, L2, L3 AND L4 INPUTS</b>					
Wake-up Filter Time	$t_{\text{WUF}}$	8.0	20	38	$\mu\text{s}$

**STATE MACHINE TIMING**

Delay Between $\overline{\text{CS}}$ LOW-to-HIGH Transition (at End of SPI Stop Command) and Stop mode Activation <sup>(116)</sup>	$t_{\text{STOP}}$	—	—	5.0	$\mu\text{s}$
Normal Request Mode Timeout (see <a href="#">Figure 35</a> )	$t_{\text{NRTOUT}}$	110	150	205	ms
Delay Between SPI Command and HS/LS Turn On <sup>(117)</sup> $9.0\text{ V} < V_{\text{SUP}} < 27\text{ V}$	$t_{\text{S-ON}}$	—	—	10	$\mu\text{s}$
Delay Between SPI Command and HS/LS Turn Off <sup>(117)</sup> $9.0\text{ V} < V_{\text{SUP}} < 27\text{ V}$	$t_{\text{S-OFF}}$	—	—	10	$\mu\text{s}$
Delay Between Normal Request and Normal Mode After a Watchdog Trigger Command (Normal Request Mode) <sup>(116)</sup>	$t_{\text{SNR2N}}$	—	—	10	$\mu\text{s}$
Delay Between $\overline{\text{CS}}$ Wake-up ( $\overline{\text{CS}}$ LOW to HIGH) in Stop mode and: Normal Request mode, VDD ON and $\overline{\text{RST}}$ HIGH First Accepted SPI Command	$t_{\text{WU}\overline{\text{CS}}}$ $t_{\text{WUSPI}}$	9.0 90	15 —	80 N/A	$\mu\text{s}$
Minimum Time Between Rising and Falling Edge on the $\overline{\text{CS}}$	$t_{2\overline{\text{CS}}}$	4.0	—	—	$\mu\text{s}$

**LIN PHYSICAL LAYER: DRIVER CHARACTERISTICS FOR NORMAL SLEW RATE - 20.0 KBIT/SEC<sup>(118), (119)</sup>**

Duty Cycle 1: $D1 = t_{\text{BUS\_REC(MIN)}} / (2 \times t_{\text{BIT}})$ , $t_{\text{BIT}} = 50\ \mu\text{s}$ $7.0\text{ V} \leq V_{\text{SUP}} \leq 18\text{ V}$	D1	0.396	—	—	
Duty Cycle 2: $D2 = t_{\text{BUS\_REC(MAX)}} / (2 \times t_{\text{BIT}})$ , $t_{\text{BIT}} = 50\ \mu\text{s}$ $7.6\text{ V} \leq V_{\text{SUP}} \leq 18\text{ V}$	D2	—	—	0.581	

**LIN PHYSICAL LAYER: DRIVER CHARACTERISTICS FOR SLOW SLEW RATE - 10.4 KBIT/SEC<sup>(118), (120)</sup>**

Duty Cycle 3: $D3 = t_{\text{BUS\_REC(MIN)}} / (2 \times t_{\text{BIT}})$ , $t_{\text{BIT}} = 96\ \mu\text{s}$ $7.0\text{ V} \leq V_{\text{SUP}} \leq 18\text{ V}$	D3	0.417	—	—	$\mu\text{s}$
Duty Cycle 4: $D4 = t_{\text{BUS\_REC(MAX)}} / (2 \times t_{\text{BIT}})$ , $t_{\text{BIT}} = 96\ \mu\text{s}$ $7.6\text{ V} \leq V_{\text{SUP}} \leq 18\text{ V}$	D4	—	—	0.590	$\mu\text{s}$

## Notes

116. This parameter is guaranteed by process monitoring but not production tested.  
 117. Delay between turn on or off command (rising edge on  $\overline{\text{CS}}$ ) and HS or LS ON or OFF, excluding rise or fall time due to external load.  
 118. Bus load  $R_{\text{BUS}}$  and  $C_{\text{BUS}}$  1.0 nF / 1.0 k $\Omega$ , 6.8 nF / 660 $\Omega$ , 10 nF / 500  $\Omega$ . Measurement thresholds: 50% of TXD signal to LIN signal threshold defined at each parameter. See [Figure 29](#).  
 119. See [Figure 30](#).  
 120. See [Figure 31](#).

**Table 36. Dynamic Electrical Characteristics (continued)**

Characteristics noted under conditions  $5.5\text{ V} \leq V_{\text{SUP}} \leq 18\text{ V}$ ,  $-40^\circ\text{C} \leq T_A \leq 125^\circ\text{C}$  for the 33912 and  $-40^\circ\text{C} \leq T_A \leq 85^\circ\text{C}$  for the 34912, unless otherwise noted. Typical values noted reflect the approximate parameter mean at  $T_A = 25^\circ\text{C}$  under nominal conditions, unless otherwise noted.

Characteristic	Symbol	Min	Typ	Max	Unit
<b>LIN PHYSICAL LAYER: DRIVER CHARACTERISTICS FOR FAST SLEW RATE</b>					
LIN Fast Slew Rate (Programming mode)	SR <sub>FAST</sub>	—	20	—	V/ $\mu\text{s}$
<b>LIN PHYSICAL LAYER: CHARACTERISTICS AND WAKE-UP TIMINGS<sup>(121)</sup></b>					
Propagation Delay and Symmetry <sup>(122)</sup>					$\mu\text{s}$
Propagation Delay Receiver, $t_{\text{REC\_PD}} = \text{MAX}(t_{\text{REC\_PDR}}, t_{\text{REC\_PDF}})$	$t_{\text{REC\_PD}}$	—	3.0	6.0	
Symmetry of Receiver Propagation Delay $t_{\text{REC\_PDF}} - t_{\text{REC\_PDR}}$	$t_{\text{REC\_SYM}}$	-2.0	—	2.0	
Bus Wake-up Deglitcher (Sleep and Stop modes) <sup>(123)</sup>	$t_{\text{PROPWL}}$	42	70	95	$\mu\text{s}$
Bus Wake-up Event Reported					$\mu\text{s}$
From Sleep mode <sup>(124)</sup>	$t_{\text{WAKE}}$	—	—	1500	
From Stop mode <sup>(125)</sup>	$t_{\text{WAKE}}$	9.0	13	17	
TXD Permanent Dominant State Delay	$t_{\text{TXDDOM}}$	0.65	1.0	1.35	s
<b>PULSE WIDTH MODULATION INPUT PIN (PWMIN)</b>					
PWMIN pin <sup>(126)</sup>	$f_{\text{PWMIN}}$				kHz
Max. frequency to drive HS and LS output pins		-	10	-	

## Notes

121.  $V_{\text{SUP}}$  from 7.0 V to 18 V, bus load  $R_{\text{BUS}}$  and  $C_{\text{BUS}}$  1.0 nF / 1.0 k $\Omega$ , 6.8 nF / 660  $\Omega$ , 10 nF / 500  $\Omega$ . Measurement thresholds: 50% of TXD signal to LIN signal threshold defined at each parameter. See [Figure 29](#).
122. See [Figure 32](#).
123. See [Figure 33](#) for Sleep and [Figure 34](#) for Stop mode.
124. The measurement is done with 1 $\mu\text{F}$  capacitor and 0 mA current load on  $V_{\text{DD}}$ . The value takes into account the delay to charge the capacitor. The delay is measured between the bus wake-up threshold ( $V_{\text{BUSWU}}$ ) rising edge of the LIN bus and when  $V_{\text{DD}}$  reaches 3.0 V. See [Figure 33](#). The delay depends of the load and capacitor on  $V_{\text{DD}}$ .
125. In Stop mode, the delay is measured between the bus wake-up threshold ( $V_{\text{BUSWU}}$ ) and the falling edge of the  $\overline{\text{IRQ}}$  pin. See [Figure 34](#).
126. This parameter is guaranteed by process monitoring but not production tested.

**TIMING DIAGRAMS**

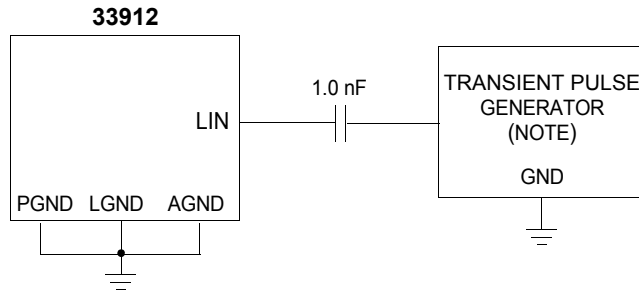

**Note** Waveform per ISO 7637-2. Test Pulses 1, 2, 3a, 3b.

**Figure 27. Test Circuit for Transient Test Pulses (LIN)**

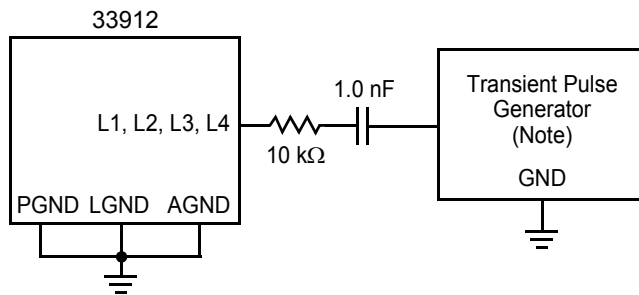

**Note** Waveform per ISO 7637-2. Test Pulses 1, 2, 3a, 3b,.

**Figure 28. Test Circuit for Transient Test Pulses (Lx)**

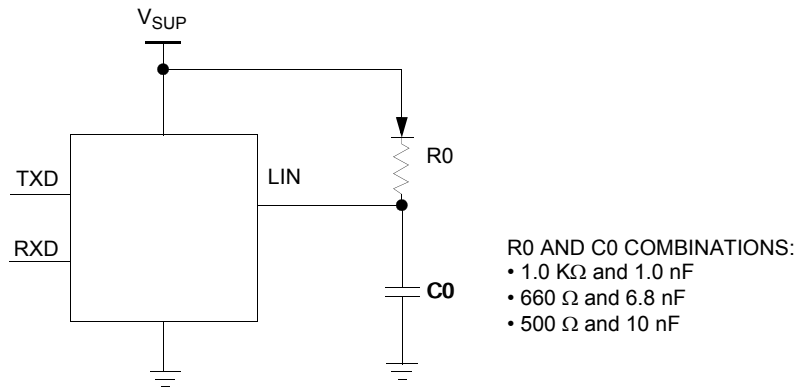

**Figure 29. Test Circuit for LIN Timing Measurements**



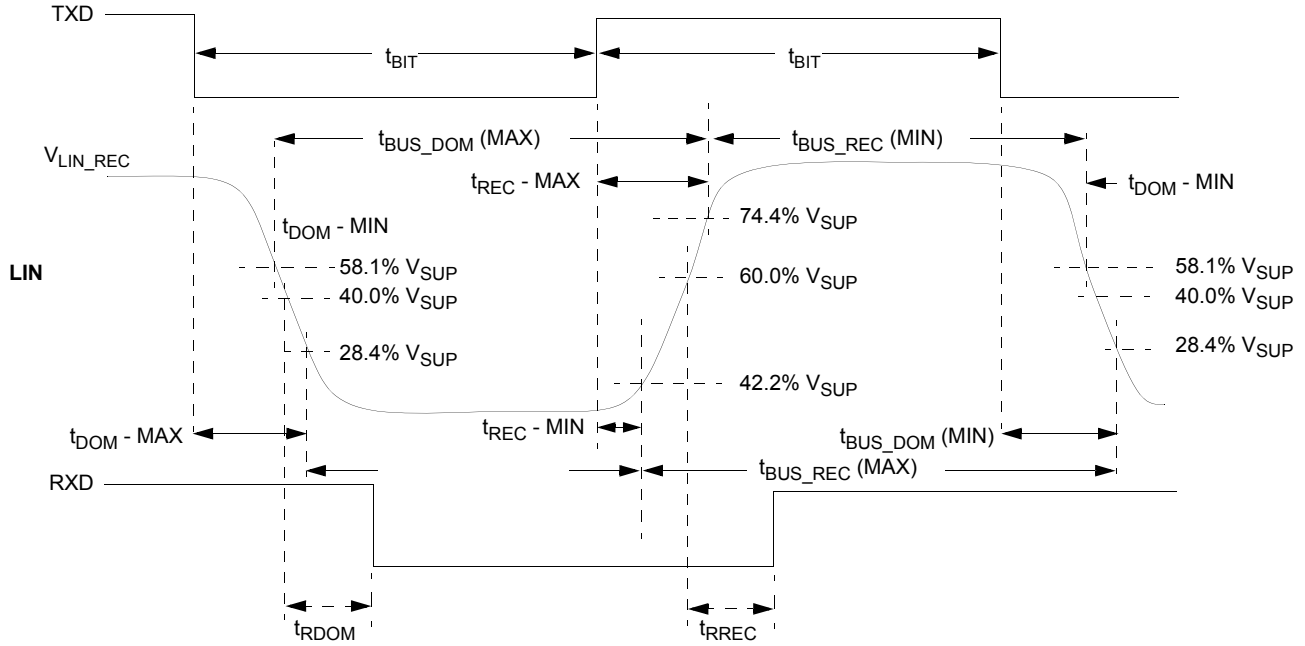

Figure 30. LIN Timing Measurements for Normal Slew Rate

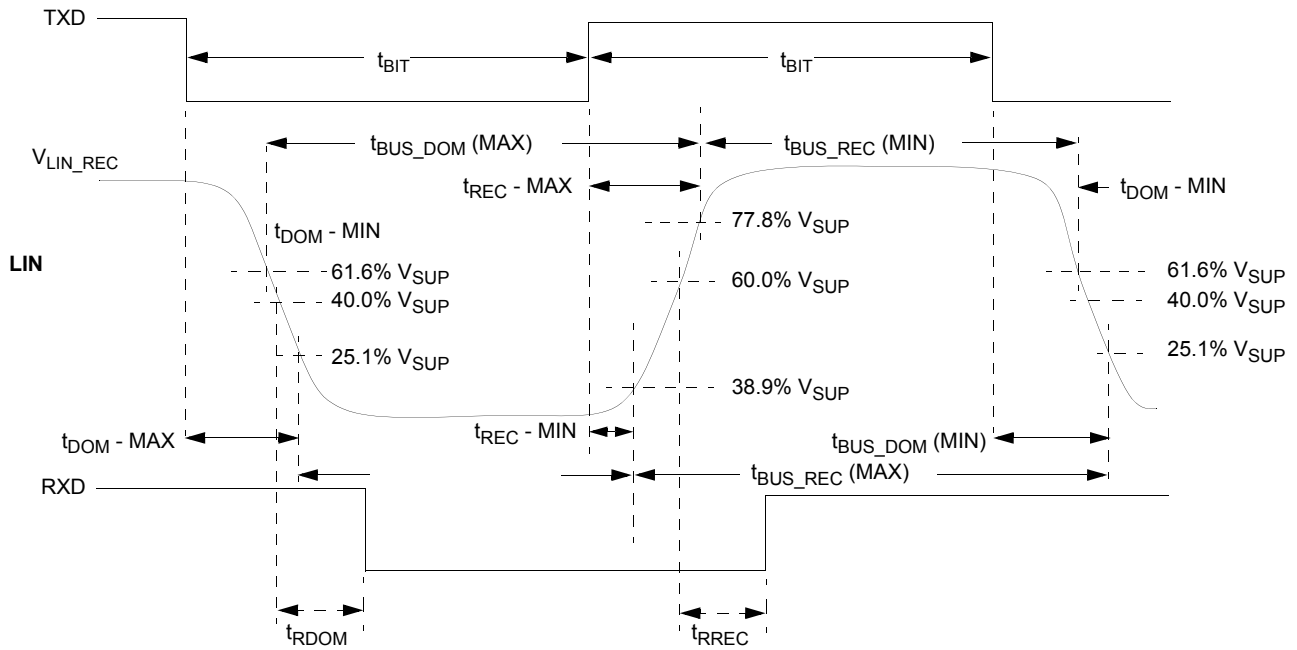

Figure 31. LIN Timing Measurements for Slow Slew Rate

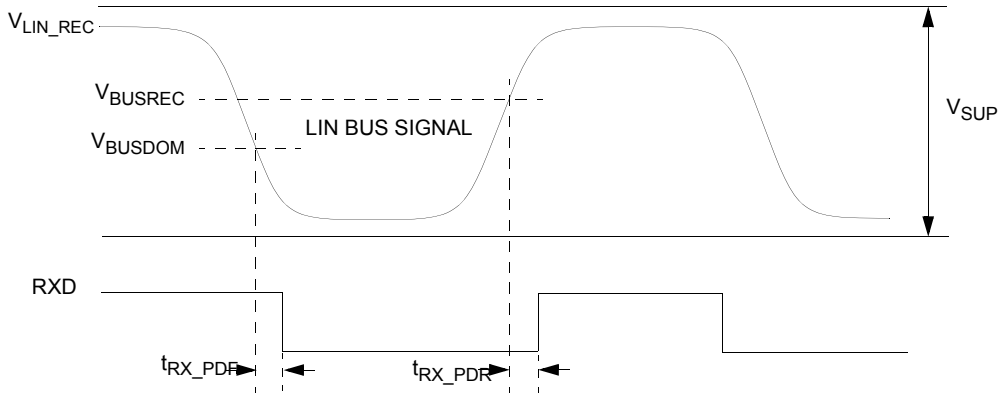

Figure 32. LIN Receiver Timing

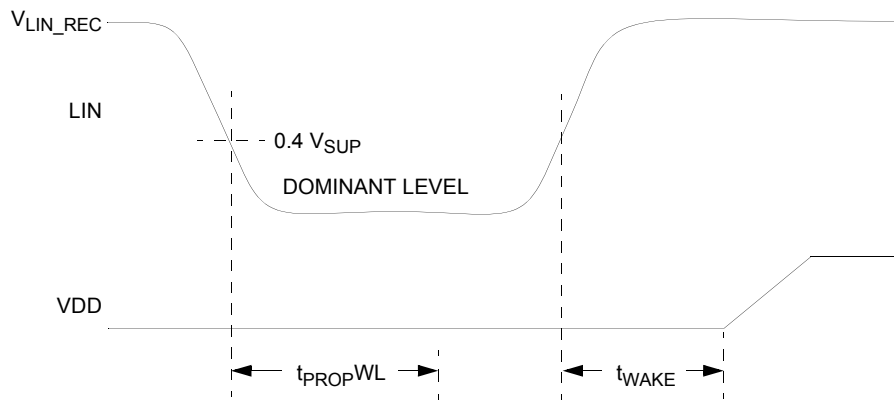

Figure 33. LIN Wake-up Sleep Mode Timing

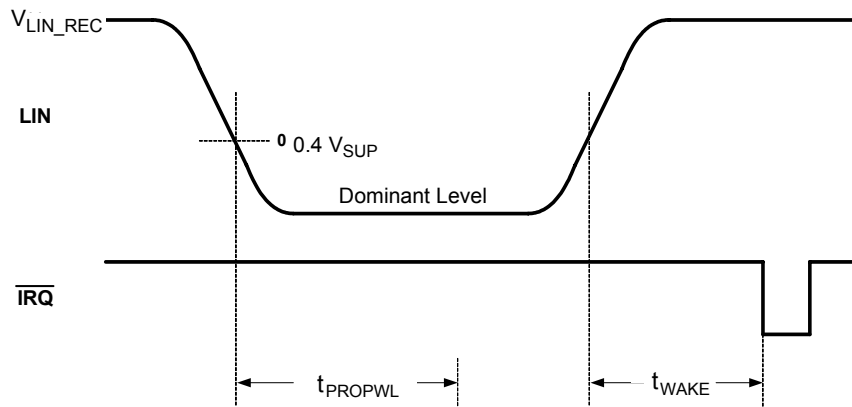

Figure 34. LIN Wake-up Stop Mode Timing

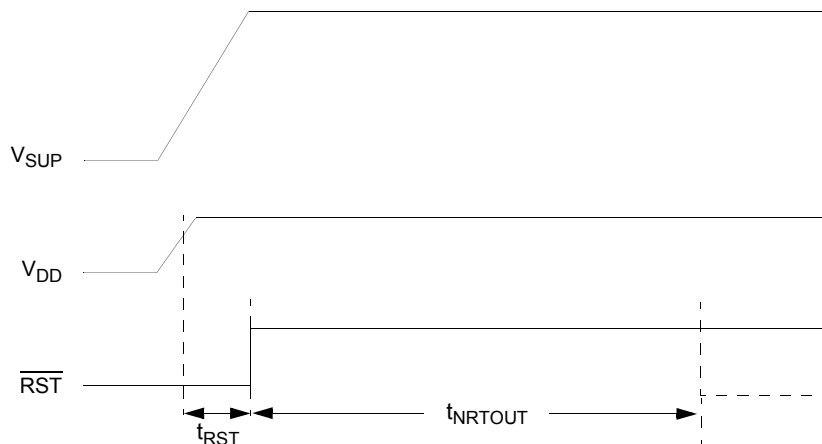

Figure 35. Power On Reset and Normal Request Timeout Timing

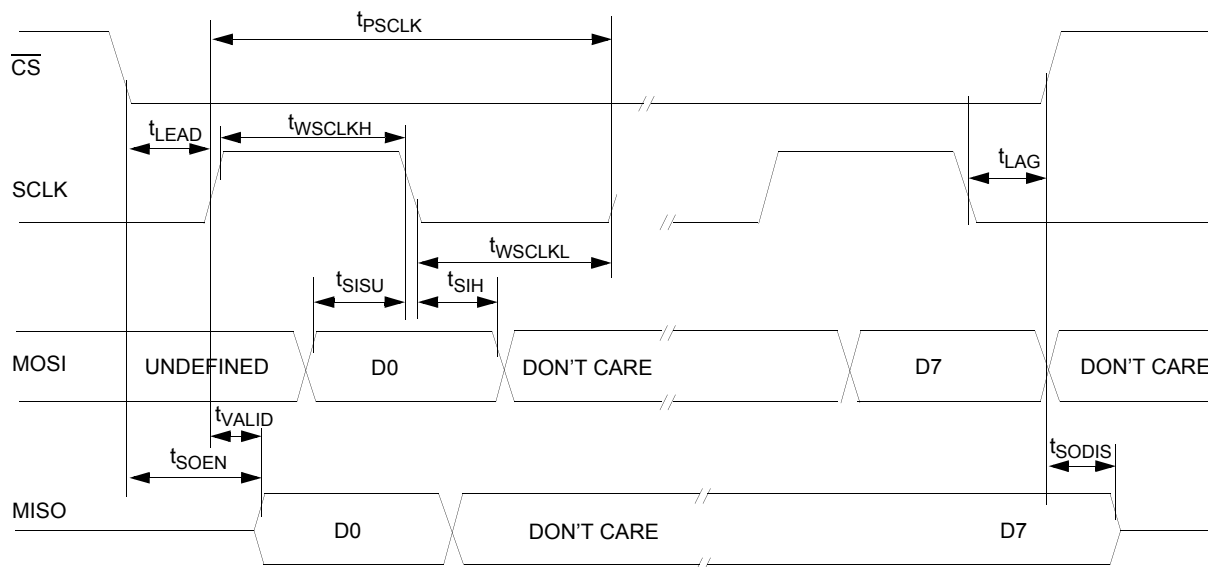

Figure 36. SPI Timing Characteristics

## FUNCTIONAL DESCRIPTION

### INTRODUCTION

The 33912 was designed and developed as a highly integrated and cost-effective solution for automotive and industrial applications. For automotive body electronics, the 33912 is well suited to perform relay control in applications like window lift, sunroof, etc. via LIN bus.

Power switches are provided on the device configured as high side and low side outputs. Other ports are also provided,

which include a current and voltage sense port, a Hall Sensor port supply, and four wake-up capable pins. An internal voltage regulator provides power to a MCU device.

Also included in this device is a LIN physical layer, which communicates using a single wire. This enables this device to be compatible with 3-wire bus systems, where one wire is used for communication, one for battery, and one for ground.

### FUNCTIONAL PIN DESCRIPTION

See [Figure 1, 33912 Simplified Application Diagram](#), for a graphic representation of the various pins referred to in the following paragraphs. Also, see the pin diagram on page [50](#) for a description of the pin locations in the package.

#### RECEIVER OUTPUT PIN (RXD)

The RXD pin is a digital output. It is the receiver output of the LIN interface and reports the state of the bus voltage: RXD Low when LIN bus is dominant, RXD High when LIN bus is recessive.

#### TRANSMITTER INPUT PIN (TXD)

The TXD pin is a digital input. It is the transmitter input of the LIN interface and controls the state of the bus output (dominant when TXD is Low, recessive when TXD is High).

This pin has an internal pull-up to force recessive state in case the input is left floating.

#### LIN BUS PIN (LIN)

The LIN pin represents the single-wire bus transmitter and receiver. It is suited for automotive bus systems and is compliant to the LIN bus specification 2.0.

The LIN interface is only active during Normal and Normal Request modes.

#### SERIAL DATA CLOCK PIN (SCLK)

The SCLK pin is the SPI clock input pin. MISO data changes on the negative transition of the SCLK. MOSI is sampled on the positive edge of the SCLK.

#### MASTER OUT SLAVE IN PIN (MOSI)

The MOSI digital pin receives SPI data from the MCU. This data input is sampled on the positive edge of SCLK.

#### MASTER IN SLAVE OUT PIN (MISO)

The MISO pin sends data to an SPI-enabled MCU. It is a digital tri-state output used to shift serial data to the microcontroller. Data on this output pin changes on the negative edge of the SCLK. When  $\overline{CS}$  is High, this pin will remain in high-impedance state.

#### CHIP SELECT PIN ( $\overline{CS}$ )

$\overline{CS}$  is an active low digital input. It must remain low during a valid SPI communication and allow for several devices to be connected in the same SPI bus without contention. A rising edge on  $\overline{CS}$  signals the end of the transmission and the moment the data shifted in is latched. A valid transmission must consist of 8 bits only.

While in STOP mode, a low-to-high level transition on this pin will generate a wake-up condition for the 33912.

#### ANALOG MULTIPLEXER PIN (ADOUT0)

The ADOUT0 pin can be configured via the SPI to allow the MCU A/D converter to read the several inputs of the Analog Multiplexer, including the VSENSE, L1, L2, L3, L4 input voltages, and the internal junction temperature.

#### CURRENT SENSE AMPLIFIER PIN (ADOUT1)

The ADOUT1 pin is an analog interface to the MCU A/D converter. It allows the MCU to read the output of the current sense amplifier.

#### PWM INPUT CONTROL PIN (PWMIN)

This digital input can control the high sides and low sides drivers in Normal Request- and Normal mode.

To enable PWM control, the MCU must perform a write operation to the High Side Control Register (HSCR) or the Low Side Control Register (LSCR).

This pin has an internal 20  $\mu$ A current pull-up.

## RESET PIN ( $\overline{\text{RST}}$ )

This bidirectional pin is used to reset the MCU in case the 33912 detects a reset condition, or to inform the 33912 that the MCU has just been reset. After release of the  $\overline{\text{RST}}$  pin, Normal Request mode is entered.

The  $\overline{\text{RST}}$  pin is an active low filtered input and output formed by a weak pull-up and a switchable pull-down structure which allows this pin to be shorted either to  $V_{\text{DD}}$  or to GND during software development, without the risk of destroying the driver.

## INTERRUPT PIN ( $\overline{\text{IRQ}}$ )

The  $\overline{\text{IRQ}}$  pin is a digital output used to signal events or faults to the MCU while in Normal and Normal Request mode or to signal a wake-up from Stop mode. This active low output will transition to high only after the interrupt is acknowledged by a SPI read of the respective status bits.

## WATCHDOG CONFIGURATION PIN (WDCONF)

The WDCONF pin is the configuration pin for the internal watchdog. A resistor can be connected to this pin to configure the window watchdog period. When connected directly to ground, the watchdog will be disabled. When this pin is left open, the watchdog period is fixed to its lower precision internal default value (150 ms typical).

## GROUND CONNECTION PINS (AGND, PGND, LGND)

The AGND, PGND and LGND pins are the Analog and Power ground pins.

The AGND pin is the ground reference of the voltage regulator and the current sense module.

The PGND and LGND pins are used for high current load return as in the relay-drivers and LIN interface pin.

Note: PGND, AGND and LGND pins must be connected together.

## CURRENT SENSE AMPLIFIER INPUT PINS (ISENSEH AND ISENSEL)

The ISENSEH and ISENSEL pins are the input pins of a ground compatible differential amplifier designed to be used to sense the voltage drop over a shunt resistor. The main purpose of this amplifier is to implement accurate current sensors. The gain of the differential amplifier can be set by SPI.

## LOW SIDE PINS (LS1 AND LS2)

LS1 and LS2 are the low side driver outputs. Those outputs are short-circuit protected and include active clamp circuitry to drive inductive loads. Due to the energy clamp

voltage on this pin, it can raise above the battery level when switched off. The switches are controlled through the SPI and can be configured to respond to a signal applied to the PWMIN input pin.

Both low side switches are protected against overheating.

## DIGITAL/ANALOG PINS (L1, L2, L3 AND L4)

The Lx pins are multi purpose inputs. They can be used as digital inputs, which can be sampled by reading the SPI and used for wake-up when 33912 is in low power mode or used as analog inputs for the analog multiplexer. When used to sense voltage outside the module, a 33 kohms series resistor must be used on each input.

When used as wake-up inputs L1-L4 can be configured to operate in cyclic-sense mode. In this mode one of the high side switches is configured to be periodically turned on and sample the wake-up inputs. If a state change is detected between two cycles a wake-up is initiated. The 33912 can also wake-up from Stop or Sleep by a simple state change on L1-L4.

When used as analog inputs, the voltage present on the Lx pins is scaled down by an selectable internal voltage divider and can be routed to the ADOUT0 output through the analog multiplexer.

Note: If an Lx input is selected in the analog multiplexer, it will be disabled as a digital input and remains disabled in low power mode. No wake-up feature is available in that condition.

When an Lx input is not selected in the analog multiplexer, the voltage divider is disconnected from that input.

## HIGH SIDE OUTPUT PINS (HS1 AND HS2)

These two high side switches are able to drive loads such as relays or lamps. Their structures are connected to the VS2 supply pin. The pins are short-circuit protected and both outputs are also protected against overheating.

HS1 and HS2 are controlled by SPI and can respond to a signal applied to the PWMIN input pin.

HS1 and HS2 outputs can also be used during low-power mode for the cyclic-sense of the wake inputs.

## POWER SUPPLY PINS (VS1 AND VS2)

Those are the battery level voltage supply pins. In an application, VS1 and VS2 pins must be protected against reverse battery connection and negative transient voltages with external components. These pins sustain standard automotive voltage conditions such as a load dump at 40 V.

The high side switches (HS1 and HS2) are supplied by the VS2 pin. All other internal blocks are supplied by VS1 pin.

**VOLTAGE SENSE PIN (VSENSE)**

This input can be connected directly to the battery line. It is protected against battery reverse connection. The voltage present in this input is scaled down by an internal voltage divider, and can be routed to the ADOUT0 output pin and used by the MCU to read the battery voltage.

The ESD structure on this pin allows for excursion up to +40 V and down to -27 V, allowing this pin to be connected directly to the battery line. It is strongly recommended to connect a 10 kohm resistor in series with this pin for protection purposes.

**HALL SENSOR SWITCHABLE SUPPLY PIN (HVDD)**

This pin provides a switchable supply for external hall sensors. While in Normal mode, this current limited output can be controlled through the SPI.

The HVDD pin needs to be connected to an external capacitor to stabilize the regulated output voltage.

**+5V MAIN REGULATOR OUTPUT PIN (VDD)**

An external capacitor has to be placed on the VDD pin to stabilize the regulated output voltage. The VDD pin is intended to supply a microcontroller. The pin is current limited against shorts to GND and over-temperature protected.

During Stop mode, the voltage regulator does not operate with its full drive capabilities and the output current is limited.

During Sleep mode, the regulator output is completely shut down.

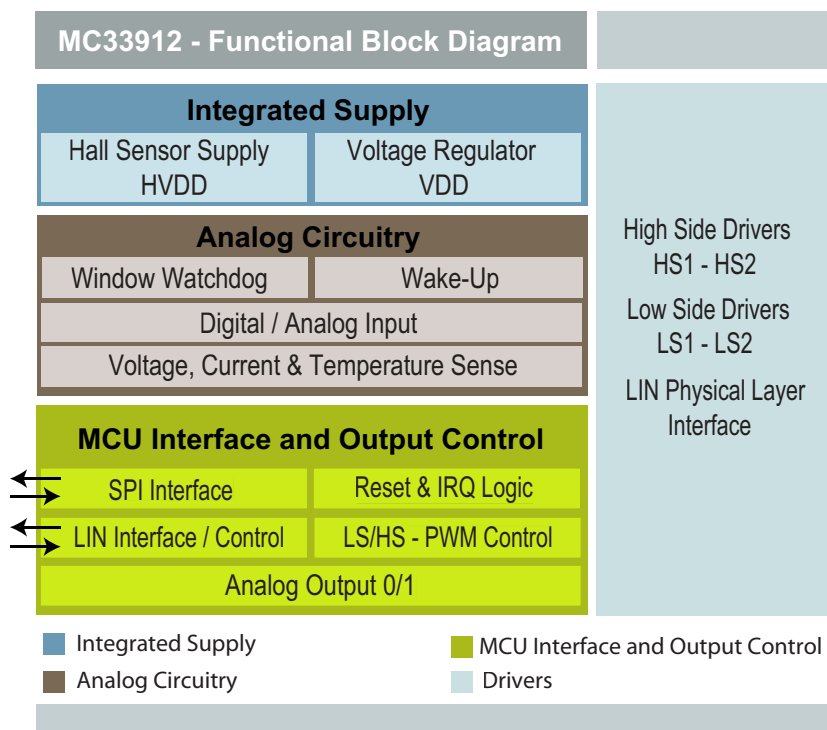
**FUNCTIONAL INTERNAL BLOCK DESCRIPTION****Figure 37. Functional Internal Block Diagram****ANALOG CIRCUITRY**

The 33912 is designed to operate under automotive operating conditions. A fully configurable window watchdog circuit will reset the connected MCU in case of an overflow. Two low power modes are available with several different wake-up sources to reactivate the device. Four analog / digital inputs can be sensed or used as the wake-up source. The device is capable of sensing the supply voltage (VSENSE), the internal chip temperature (CTEMP) as well as the motor current using an external sense resistor.

**HIGH SIDE DRIVERS**

Two current and temperature protected High Side drivers with PWM capability are provided to drive small loads such as Status LED's or small lamps. Both Drivers can be configured for periodic sense during low power modes.

**LOW SIDE DRIVERS**

Two current and temperature protected Low Side drivers with PWM capability are provided to drive H-Bridge type relays for power motor applications

**MCU INTERFACE**

The 33912 is providing its control and status information through a standard 8-Bit SPI interface. Critical system events such as Low- or High-voltage/Temperature conditions as well as over-current conditions in any of the driver stages can be reported to the connected MCU via IRQ or RST. Both Low Side and both High Side driver outputs can be controlled via the SPI register as well as the PWMIN input. The integrated LIN physical layer interface can be configured via SPI register and its communication is driven through the RXD and TXD device pins. All internal analog sources are multiplexed to the A<sub>DOUT</sub> 0 pin. The current sense analog signal is directly routed through ADO<sub>UT</sub>1.

**VOLTAGE REGULATOR OUTPUTS**

Two independent voltage regulators are implemented on the 33912. The VDD main regulator output is designed to supply a MCU with a precise 5.0 V. The switchable HVDD output is dedicated to supply small peripherals as hall sensors.

**LIN PHYSICAL LAYER INTERFACE**

The 33912 provides a LIN 2.0 compatible LIN physical layer interface with selectable slew rate and various diagnostic features.

## FUNCTIONAL DEVICE OPERATIONS

### OPERATIONAL MODES

#### Introduction

The 33912 offers three main operating modes: Normal (Run), Stop, and Sleep (Low Power). In Normal mode, the device is active and is operating under normal application conditions. The Stop and Sleep modes are low-power modes with wake-up capabilities.

In Stop mode, the voltage regulator still supplies the MCU with  $V_{DD}$  (limited current capability), while in Sleep mode the voltage regulator is turned off ( $V_{DD} = 0$  V).

Wake-up from Stop mode is initiated by a wake-up interrupt. Wake-up from Sleep mode is done by a reset and the voltage regulator is turned back on.

The selection of the different modes is controlled by the MOD1:2 bits in the Mode Control Register (MCR).

[Figure 38](#) describes how transitions are done between the different operating modes. [Table 37](#) gives an overview of the operating modes.

#### RESET MODE

The 33912 enters the Reset mode after a power up. In this mode, the RST pin is low for 1ms (typical value). After this delay, it enters the Normal Request mode and the RST pin is driven high.

The Reset mode is entered if a reset condition occurs ( $V_{DD}$  low, watchdog trigger fail, after wake-up from Sleep mode, Normal Request mode timeout occurs).

#### NORMAL REQUEST MODE

This is a temporary mode automatically accessed by the device after the Reset mode, or after a wake-up from Stop mode.

In Normal Request mode, the VDD regulator is ON, the RESET pin is High, and the LIN is operating in RX Only mode.

As soon as the device enters in the Normal Request mode an internal timer is started for 150 ms (typical value). During these 150 ms, the MCU must configure the Timing Control Register (TIMCR) and the Mode Control Register (MCR) with MOD2 and MOD1 bits set = 0, to enter the Normal mode. If within the 150ms timeout, the MCU does not command the 33912 to Normal mode, it will enter in Reset mode. If the WDCONF pin is grounded in order to disable the watchdog function, it goes directly in Normal mode after the Reset mode. If the WDCONF pin is open, the 33912 stays typically for 150 ms in Normal Request before entering in Normal mode.

#### NORMAL MODE

In Normal mode, all 33912 functions are active and can be controlled by the SPI interface and the PWMIN pin.

The VDD regulator is ON and delivers its full current capability.

If an external resistor is connected between the WDCONF pin and the Ground, the window watchdog function will be enabled.

The wake-up inputs (L1-L4) can be read as digital inputs or have its voltage routed through the analog-multiplexer.

The LIN interface has slew rate and timing compatible with the LIN protocol specification 2.0. The LIN bus can transmit and receive information.

The high side and low side switches are active and have PWM capability according to the SPI configuration.

The interrupts are generated to report failures for  $V_{SUP}$  over/under-voltage, thermal shutdown, or thermal shutdown prewarning on the main regulator.

#### SLEEP MODE

The Sleep mode is a low power mode. From Normal mode, the device enters into Sleep mode by sending one SPI command through the Mode Control Register (MCR). All blocks are in their lowest power consumption condition. Only some wake-up sources (wake-up inputs with or without cyclic sense, forced wake-up and LIN receiver) are active. The 5.0 V regulator is OFF. The internal low-power oscillator may be active if the IC is configured for cyclic-sense. In this condition, one of the high side switches is turned on periodically and the wake-up inputs are sampled.

Wake-up from Sleep mode is similar to a power-up. The device goes in Reset mode except that the SPI will report the wake-up source and the BATFAIL flag is not set.

#### STOP MODE

The Stop mode is the second low power mode, but in this case the 5.0 V regulator is ON with limited current drive capability. The application MCU is always supplied while the 33912 is operating in Stop mode.

The device can enter into Stop mode only by sending the SPI command. When the application is in this mode, it can wake-up from the 33912 side (for example: cyclic sense, force wake-up, LIN bus, wake inputs) or the MCU side ( $\overline{CS}$ ,  $\overline{RST}$  pins). Wake-up from Stop mode will transition the 33912 to Normal Request mode and generates an interrupt except if the wake-up event is a low to high transition on the  $\overline{CS}$  pin or comes from the  $\overline{RST}$  pin.

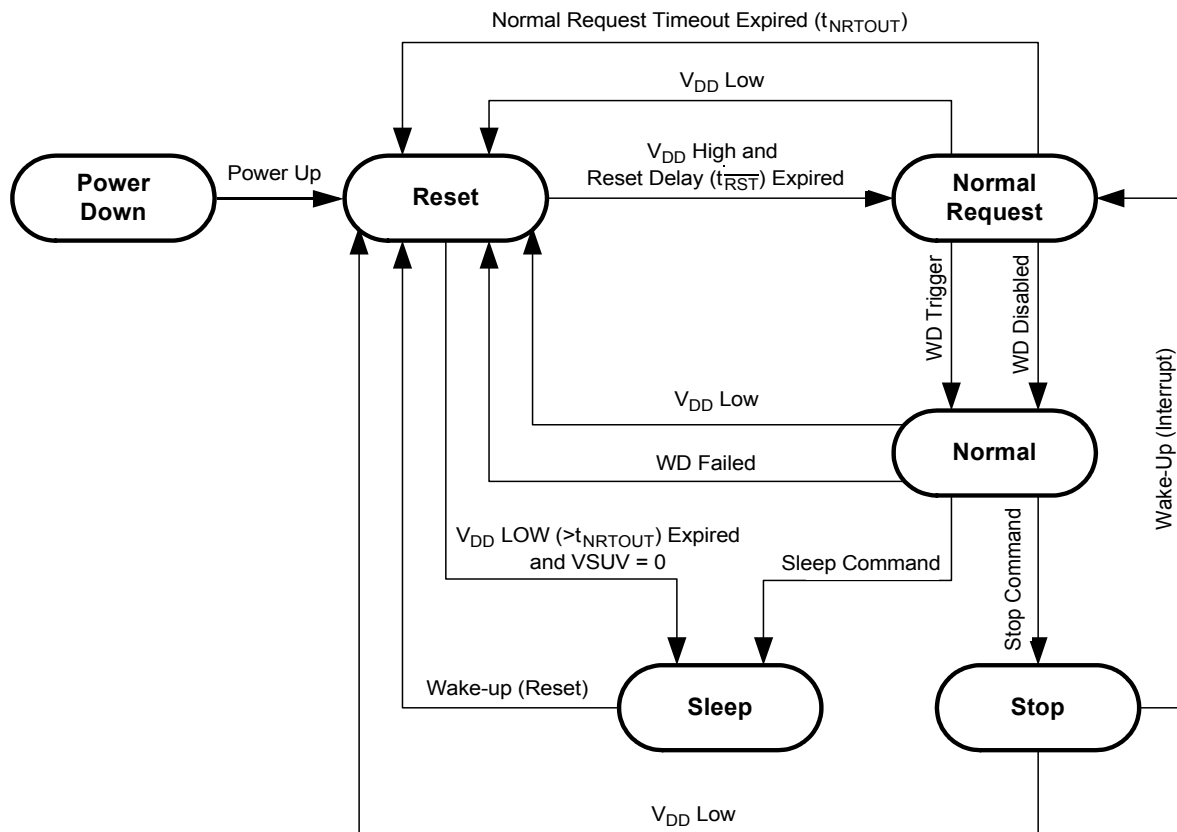

**Legend**

WD: Watchdog

WD Disabled: Watchdog disabled (WDCONF pin connected to GND)

WD Trigger: Watchdog is triggered by SPI command

WD Failed: No watchdog trigger or trigger occurs in closed window

Stop Command: Stop command sent via SPI

Sleep Command: Sleep command sent via SPI

Wake-Up from Stop Mode: L1, L2, L3 or L4 state change, LIN bus wake-up,  $\overline{CS}$  rising edge wake-up or  $\overline{RST}$  wake-up.

Wake-Up from Sleep Mode: L1, L2, L3 or L4 state change, LIN bus wake-up, Periodic wake-up.

**Figure 38. Operating Modes and Transitions**

**Table 37. Operating Modes Overview**

Function	Reset Mode	Normal Request Mode	Normal Mode	Stop Mode	Sleep Mode
VDD	Full	Full	Full	Stop	-
HVDD	-	SPI <sup>(127)</sup>	SPI	-	-
LSx	-	SPI/PWM <sup>(128)</sup>	SPI/PWM	-	-
HSx	-	SPI/PWM <sup>(128)</sup>	SPI/PWM	Note <sup>(129)</sup>	Note <sup>(130)</sup>
Analog Mux	-	SPI	SPI	-	-
Lx	-	Inputs	Inputs	Wake-up	Wake-up
Current Sense	On	On	On	-	-
LIN	-	Rx-Only	Full/Rx-Only	Rx-Only/Wake-up	Wake-up
Watchdog	-	150 ms (typ.) timeout	On <sup>(131)</sup> /Off	-	-
VSENSE	On	On	On	VDD	-

**Notes**

127. Operation can be enabled/controlled by the SPI.  
 128. Operation can be controlled by the PWMIN input.  
 129. HSx switches can be configured for cyclic sense operation in Stop mode.  
 130. HSx switches can be configured for cyclic sense operation in Sleep mode.  
 131. Windowing operation when enabled by an external resistor.

**INTERRUPTS**

Interrupts are used to signal a microcontroller that a peripheral needs to be serviced. The interrupts which can be generated, change according to the operating mode. While in Normal and Normal Request modes, the 33912 signals through interrupts special conditions which may require a MCU software action. Interrupts are not generated until all pending wake-up sources are read in the Interrupt Source Register (ISR).

While in Stop mode, interrupts are used to signal wake-up events. Sleep mode does not use interrupts. Wake-up is performed by powering-up the MCU. In Normal and Normal Request mode the wake-up source can be read by SPI.

The interrupts are signaled to the MCU by a low logic level of the  $\overline{\text{IRQ}}$  pin, which will remain low until the interrupt is acknowledged by a SPI read. The  $\overline{\text{IRQ}}$  pin will then be driven high.

Interrupts are only asserted while in Normal, Normal Request and Stop mode. Interrupts are not generated while the  $\overline{\text{RST}}$  pin is low.

The following is a list of the interrupt sources in Normal and Normal Request modes. Some of these can be masked by writing to the SPI - Interrupt Mask Register (IMR).

**Low-voltage Interrupt:**

Signals when the supply line (VS1) voltage drops below the VSUV threshold ( $V_{\text{SUUV}}$ ).

**High-voltage Interrupt:**

Signals when the supply line (VS1) voltage increases above the VSOV threshold ( $V_{\text{SOV}}$ ).

**Over-temperature Prewarning:**

Signals when the 33912 temperature has reached the pre-shutdown warning threshold. It is used to warn the MCU that an over-temperature shutdown in the main 5.0 V regulator is imminent.

**LIN Over-current Shutdown / Over-temperature Shutdown / TXD Stuck At Dominant / RXD Short-circuit:**

These signal fault conditions within the LIN interface will cause the LIN driver to be disabled, except for the LIN over-current condition. In order to restart operation, the fault must be removed and must be acknowledged by reading the SPI.

The LINOC bit functionality in the LIN Status Register (LINSR) is to indicate an LIN over-current has occurred and the driver remains enabled.

**High Side Over-temperature Shutdown:**

Signals a shutdown in the high side outputs.

**Low Side Over-temperature Shutdown:**

Signals a shutdown in the low side outputs.

**RESET**

To reset a MCU the 33912 drives the  $\overline{\text{RST}}$  pin low for the time the reset condition lasts.

After the reset source is removed, the state machine will drive the  $\overline{\text{RST}}$  output low for at least 1.0 ms (typical value) before driving it high.

In the 33912, four main reset sources exist:

### 5.0 V Regulator Low-voltage-Reset ( $\overline{\text{V}_{\text{RSTTH}}}$ )

The 5.0 V regulator output  $\text{V}_{\text{DD}}$  is continuously monitored against brown outs. If the supply monitor detects that the voltage at the VDD pin has dropped below the reset threshold  $\overline{\text{V}_{\text{RSTTH}}}$  the 33912 will issue a reset. In case of over-temperature, the voltage regulator will be disabled and the voltage monitoring will issue a VDDOT Flag independently of the  $\text{V}_{\text{DD}}$  voltage.

### Window Watchdog Overflow

If the watchdog counter is not properly serviced while its window is open, the 33912 will detect an MCU software run-away and will reset the microcontroller.

### Wake-up From Sleep Mode

During Sleep mode, the 5V regulator is not active, hence all wake-up requests from Sleep mode require a power-up/reset sequence.

### External Reset

The 33912 has a bidirectional reset pin which drives the device to a safe state (same as Reset mode) for as long as this pin is held low. The  $\overline{\text{RST}}$  pin must be held low long enough to pass the internal glitch filter and get recognized by the internal reset circuit. This functionality is also active in Stop mode.

After the  $\overline{\text{RST}}$  pin is released, there is no extra  $t_{\overline{\text{RST}}}$  to be considered.

## WAKE-UP CAPABILITIES

Once entered into one of the low-power modes (Sleep or Stop) only wake-up sources can bring the device into Normal mode operation.

In Stop mode, a wake-up is signaled to the MCU as an interrupt, while in Sleep mode the wake-up is performed by activating the 5.0 V regulator and resetting the MCU. In both cases the MCU can detect the wake-up source by accessing the SPI registers. There is no specific SPI register bit to signal a  $\overline{\text{CS}}$  wake-up or external reset. If necessary this condition is detected by excluding all other possible wake-up sources.

### Wake-up from Wake-up inputs (L1-L4) with cyclic sense disabled

The wake-up lines are dedicated to sense state changes of external switches and wake-up the MCU (in Sleep or Stop mode).

In order to select and activate direct wake-up from Lx inputs, the Wake-up Control Register (WUCR) must be configured with appropriate LxWE inputs enabled or disabled. The wake-up input's state is read through the Wake-up Status Register (WUSR).

Lx inputs are also used to perform cyclic-sense wake-up.

Note: Selecting an Lx input in the analog multiplexer before entering low power mode will disable the wake-up capability of the Lx input

### Wake-up from Wake-up inputs (L1-L4) with cyclic sense timer enabled

The SBCLIN can wake-up at the end of a cyclic sense period if on one of the four wake-up input lines (L1-L4) a state change occurs. The HSx switch is activated in Sleep or Stop modes from an internal timer. Cyclic sense and force wake-up are exclusive. If cyclic sense is enabled, the force wake-up can not be enabled.

In order to select and activate the cyclic sense wake-up from Lx inputs, before entering in low power modes (Stop or Sleep modes), the following SPI set-up has to be performed:

In WUCR: select the Lx input to WU-enable.

In HSCR: enable the desired HSx.

- In TIMCR: select the  $\overline{\text{CS/WD}}$  bit and determine the cyclic sense period with CYSTx bits.
- Perform Goto Sleep/Stop command.

### Forced Wake-up

The 33912 can wake-up automatically after a predetermined time spent in Sleep or Stop mode. Cyclic sense and Forced wake-up are exclusive. If Forced wake-up is enabled, the Cyclic Sense can not be enabled.

To determine the wake-up period, the following SPI set-up has to be sent before entering in low power modes:

- In TIMCR: select the  $\overline{\text{CS/WD}}$  bit and determine the low power mode period with CYSTx bits.
- In HSCR: all HSx bits must be disabled.

### $\overline{\text{CS}}$ Wake-up

While in Stop mode, a rising edge on the  $\overline{\text{CS}}$  will cause a wake-up. The  $\overline{\text{CS}}$  wake-up does not generate an interrupt, and is not reported on SPI.

### LIN Wake-up

While in the low-power mode, the 33912 monitors the activity on the LIN bus. A dominant pulse larger than  $t_{\text{PROPWL}}$  followed by a dominant to recessive transition will cause a LIN wake-up. This behavior protects the system from a short to ground bus condition.

### **RST Wake-up**

While in Stop mode, the 33912 can wake-up when the  $\overline{\text{RST}}$  pin is held low long enough to pass the internal glitch filter. Then, the 33912 will change to Normal Request or Normal modes depending on the WDCONF pin configuration. The  $\overline{\text{RST}}$  wake-up does not generate an interrupt and is not reported via SPI.

From Stop mode, the following wake-up events can be configured:

- Wake-up from Lx inputs without cyclic sense
- Cyclic sense wake-up inputs
- Force wake-up
- $\overline{\text{CS}}$  wake-up
- LIN wake-up
- $\overline{\text{RST}}$  wake-up

From Sleep mode, the following wake-up events can be configured:

- Wake-up from Lx inputs without cyclic sense
- Cyclic sense wake-up inputs
- Force wake-up
- LIN wake-up

### **WINDOW WATCHDOG**

The 33912 includes a configurable window watchdog which is active in Normal mode. The watchdog can be configured by an external resistor connected to the WDCONF pin. The resistor is used to achieve higher precision in the timebase used for the watchdog.

SPI clears are performed by writing through the SPI in the MOD bits of the Mode Control Register (MCR).

During the first half of the SPI timeout, watchdog clears are not allowed, but after the first half of the SPI timeout window, the clear operation opens. If a clear operation is performed outside the window, the 33912 will reset the MCU, in the same way as when the watchdog overflows.

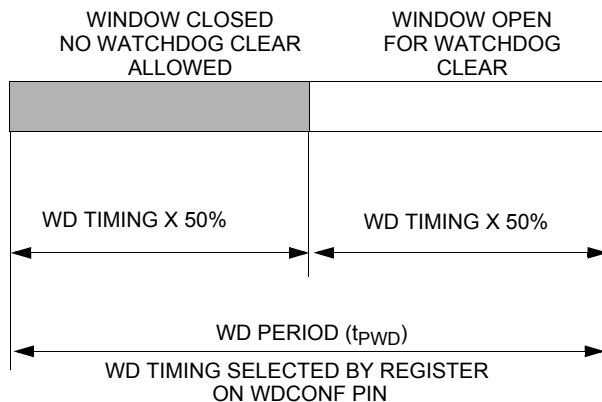

**Figure 39. Window Watchdog Operation**

To disable the watchdog function in Normal mode the user must connect the WDCONF pin to ground. This measure effectively disables Normal Request mode. The WDOFF bit in the Watchdog Status Register (WDSR) will be set. This condition is only detected during Reset mode.

If neither a resistor nor a connection to ground is detected, the watchdog falls back to the internal lower precision timebase of 150 ms (typ.) and signals the faulty condition through the Watchdog Status Register (WDSR).

The watchdog timebase can be further divided by a prescaler which can be configured by the Timing Control Register (TIMCR). During Normal Request mode, the window watchdog is not active but there is a 150 ms (typ.) timeout for leaving the Normal Request mode. In case of a timeout, the 33912 will enter into Reset mode, resetting the microcontroller before entering again into Normal Request mode.

### **HIGH SIDE OUTPUT PINS HS1 AND HS2**

These outputs are two high side drivers intended to drive small resistive loads or LEDs incorporating the following features:

- PWM capability (software maskable)
- Open load detection
- Current limitation
- Over-temperature shutdown (with maskable interrupt)
- High-voltage shutdown (software maskable)
- Cyclic sense

The high side switches are controlled by the bits HS1:2 in the High Side Control Register (HSCR).

#### **PWM Capability (direct access)**

Each high side driver offers additional (to the SPI control) direct control via the PWMIN pin.

If both the bits HS1 and PWMHS1 are set in the High Side Control Register (HSCR), then the HS1 driver is turned on if the PWMIN pin is high and turned off if the PWMIN pin is low. This applies to HS2 configuring HS2 and PWMHS2 bits.

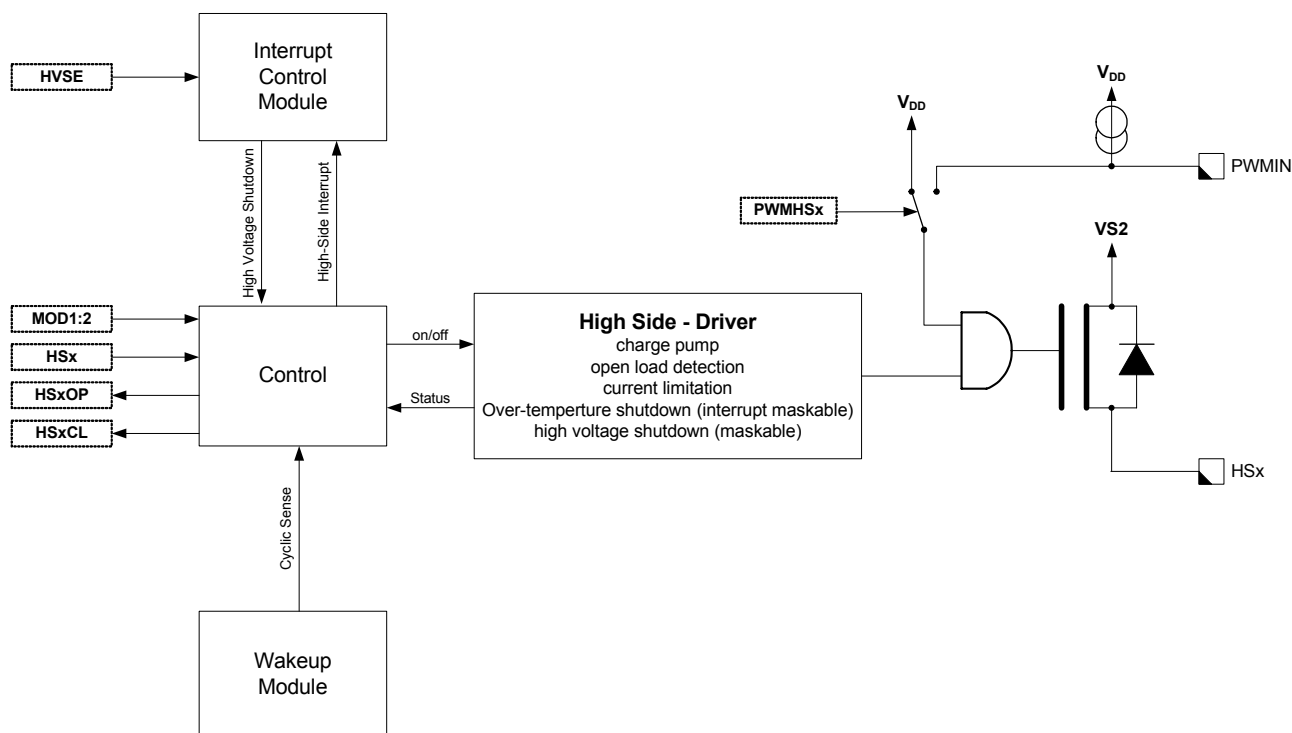

Figure 40. High Side Drivers HS1 and HS2

### Open Load Detection

Each high side driver signals an open load condition if the current through the high side is below the open load current threshold.

The open load condition is indicated with the bits HS1OP and HS2OP in the High Side Status Register (HSSR).

### Current Limitation

Each high side driver has an output current limitation. In combination with the over-temperature shutdown the high-side drivers are protected against over-current and short-circuit failures.

When the driver operates in the current limitation area, it is indicated with the bits HS1CL and HS2CL in the HSSR.

Note: If the driver is operating in current limitation mode, excessive power might be dissipated.

### Over-temperature Protection (HS Interrupt)

Both high side drivers are protected against over-temperature. In case of an over-temperature condition both high side drivers are shut down and the event is latched in the

Interrupt Control Module. The shutdown is indicated as HS Interrupt in the Interrupt Source Register (ISR).

A thermal shutdown of the high side drivers is indicated by setting all HSxOP and HSxCL bits simultaneously.

If the bit HSM is set in the Interrupt Mask Register (IMR), then an interrupt (IRQ) is generated.

A write to the High Side Control Register (HSCR), when the over-temperature condition is gone, will re-enable the high side drivers.

### High-voltage Shutdown

In case of a high voltage condition and if the high voltage shutdown is enabled (bit HVSE in the Mode Control Register (MCR) is set) both high side drivers are shut down.

A write to the High Side Control Register (HSCR), when the high voltage condition is gone, will re-enable the high side drivers.

### Sleep And Stop Mode

The high side drivers can be enabled to operate in Sleep and Stop mode for cyclic sensing. Also see [Table 37](#).

## LOW SIDE OUTPUT PINS LS1 AND LS2

These outputs are two low side drivers intended to drive relays incorporating the following features:

- PWM capability (software maskable)
- Open load detection
- Current limitation
- Over-temperature shutdown (with maskable interrupt)
- Active clamp (for driving relays)
- High-voltage shutdown (software maskable)

The low side switches are controlled by the bit LS1:2 in the Low Side Control Register (LSCR).

To protect the device against over-voltage when an inductive load (relay) is turned off. An active clamp will re-enable the low side FET if the voltage on the LS1 or LS2 pin exceeds a certain level.

### PWM Capability (direct access)

Each low side driver offers additional (to the SPI control) direct control via the PWMIN pin.

If both the bits LS1 and PWMLS1 are set in the Low Side Control Register (LSCR), then the LS1 driver is turned on if the PWMIN pin is high and turned off if the PWMIN pin is low. The same applies to the LS2 and PWMLS2 bits for the LS2 driver.

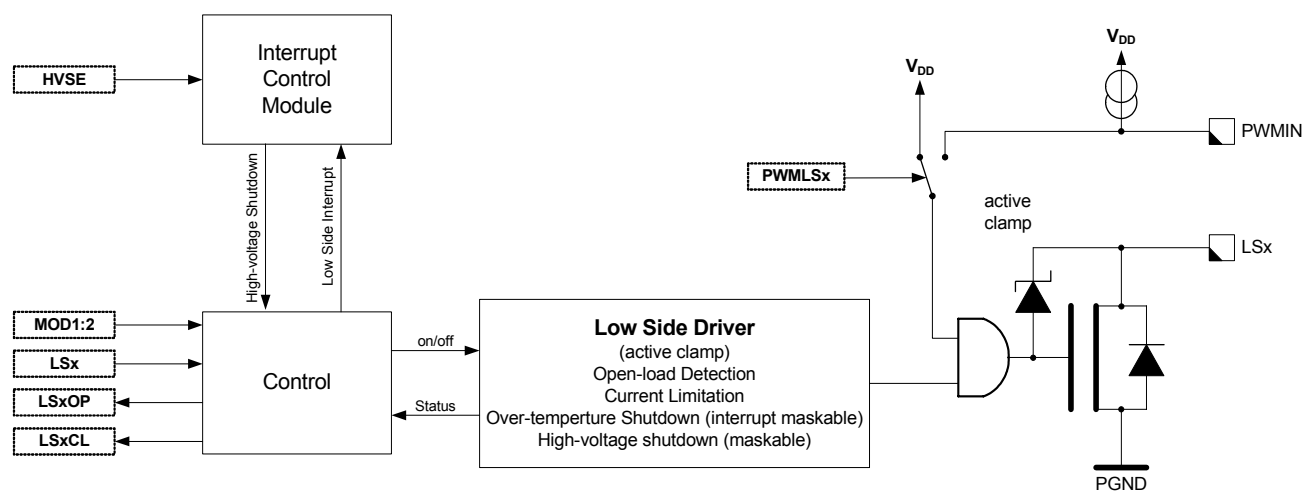

Figure 41. Low Side Drivers LS1 and LS2

### Open Load Detection

Each low side driver signals an open load condition if the current through the low side is below the open load current threshold.

The open load condition is indicated with the bit LS1OP and LS2OP in the Low Side Status Register (LSSR).

### Current Limitation

Each low side driver has a current limitation. In combination with the over-temperature shutdown the low side drivers are protected against over-current and short-circuit failures.

When the drivers operate in current limitation, this is indicated with the bits LS1CL and LS2CL in the LSSR.

Note: If the drivers are operating in current limitation mode excessive power might be dissipated.

### Over-temperature Protection (LS Interrupt)

Both low side drivers are protected against over-temperature. In case of an over-temperature condition both

low side drivers are shut down and the event is latched in the Interrupt Control Module. The shutdown is indicated as an LS Interrupt in the Interrupt Source Register (ISR).

If the bit LSM is set in the Interrupt Mask Register (IMR) than an Interrupt (IRQ) is generated.

A write to the Low Side Control Register (LSCR), when the over-temperature condition is gone, will re-enable the low side drivers.

### High-voltage Shutdown

In case of a high-voltage condition and if the high-voltage shutdown is enabled (bit HVSE in the Mode Control Register (MCR) is set) both low sides drivers are shut down.

A write to the Low Side Control Register (LSCR), when the high-voltage condition is gone, will re-enable the low side drivers.

### Sleep And Stop Mode

The low side drivers are disabled in Sleep and Stop mode. Also see [Table 37](#).

## LIN PHYSICAL LAYER

The LIN bus pin provides a physical layer for single-wire communication in automotive applications. The LIN physical layer is designed to meet the LIN physical layer specification and has the following features:

- LIN physical layer 2.0 compliant
- Slew rate selection
- Over-current shutdown
- Over-temperature shutdown
- LIN pull-up disable in Stop and Sleep modes
- Advanced diagnostics
- LIN dominant voltage level selection

The LIN driver is a low side MOSFET with over-current and thermal shutdown. An internal pull-up resistor with a serial diode structure is integrated, so no external pull-up components are required for the application in a slave node. The fall time from dominant to recessive and the rise time from recessive to dominant is controlled. The symmetry between both slopes is guaranteed.

## LIN Pin

The LIN pin offers a high susceptibility immunity level from external disturbance, guaranteeing communication during external disturbance.

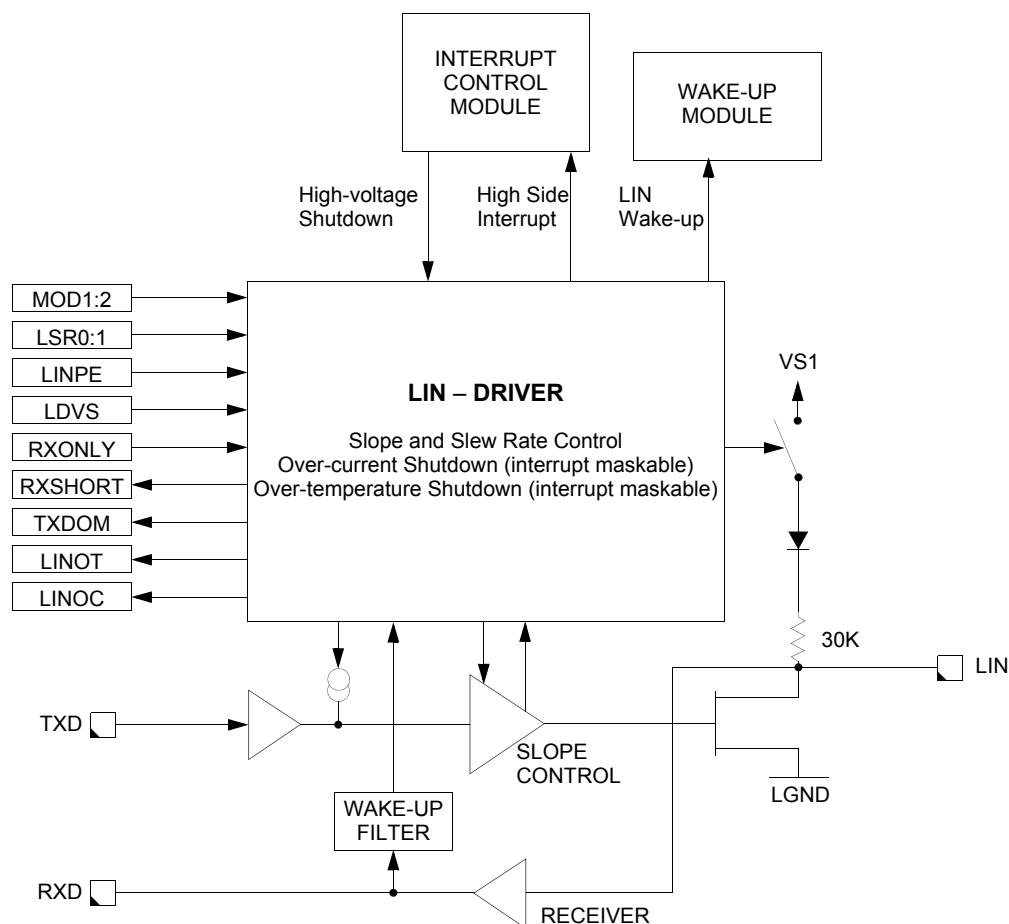

Figure 42. LIN Interface

### Slew Rate Selection

The slew rate can be selected for optimized operation at 10.4 and 20 kBit/s as well as a fast baud rate for test and programming. The slew rate can be adapted with the bits LSR 1:0 in the LIN Control Register (LINCR). The initial slew rate is optimized for 20 kBit/s.

### LIN Pull-up Disable In Stop And Sleep Modes

In cases of a LIN bus short to GND or LIN bus leakage during low-power mode, the internal pull-up resistor on the LIN pin can be disconnected by clearing the LINPE bit in the Mode Control Register (MCR). The LINPE bit also changes the Bus wake-up threshold ( $V_{BUSWU}$ ).

This feature will reduce the current consumption in STOP and SLEEP modes. It also improves performance and safe operation.



**Current Limit (LIN Interrupt)**

The output low side FET is protected against over-current conditions. In case of an over-current condition (e.g. LIN bus short to  $V_{BAT}$ ), the transmitter will not be shut down. The bit LINOC in the LIN Status Register (LINSR) is set.

If the LINM bit is set in the Interrupt Mask Register (IMR), an Interrupt  $\overline{IRQ}$  will be generated.

**Over-temperature Shutdown (LIN Interrupt)**

The output low side FET is protected against over-temperature conditions. In case of an over-temperature condition, the transmitter will be shut down and the LINOT bit in the LIN Status Register (LINSR) is set.

If the LINM bit is set in the Interrupt Mask Register (IMR), an Interrupt  $\overline{IRQ}$  will be generated.

The transmitter is automatically re-enabled once the condition is gone and TXD is high.

A read of the LIN Status Register (LINSR) with the TXD pin high, will re-enable the transmitter.

**RXD Short-circuit Detection (LIN Interrupt)**

The LIN transceiver has a short-circuit detection for the RXD output pin. In case of a short-circuit condition, either 5V or Ground, the RXSHORT bit in the LIN Status Register (LINSR) is set and the transmitter is shut down.

If the LINM bit is set in the Interrupt Mask Register (IMR), an Interrupt  $\overline{IRQ}$  will be generated.

The transmitter is automatically re-enabled once the condition is gone (transition on RXD) and TXD is high.

A read of the LIN Status Register (LINSR) without the RXD pin short-circuit condition will clear the bit RXSHORT.

**TXD Dominant Detection (LIN Interrupt)**

The LIN transceiver monitors the TXD input pin to detect a stuck in dominant (0V) condition. In case of a stuck condition (TXD pin 0 V for more than 1 second (typ.)), the transmitter is shut down and the TXDOM bit in the LIN Status Register (LINSR) is set.

If the LINM bit is set in the IMR, an Interrupt  $\overline{IRQ}$  will be generated.

The transmitter is automatically re-enabled once TXD is high.

A read of the LIN Status Register (LINSR) with the TXD pin at 5.0 V will clear the bit TXDOM.

**LIN Dominant Voltage Level Selection**

The LIN dominant voltage level can be selected by the bit LDVS in the LIN Control Register (LINCR).

**LIN Receiver Operation Only**

While in Normal mode, the activation of the RXONLY bit disables the LIN TXD driver. If case of a LIN error condition, this bit is automatically set. If a low-power mode is selected with this bit set, the LIN wake-up functionality is disabled, then in STOP mode, the RXD pin will reflect the state of the LIN bus.

**STOP Mode And Wake-up Feature**

During Stop mode operation, the transmitter of the physical layer is disabled. If the LIN-PU bit was set in the Stop mode sequence, the internal pull-up resistor is disconnected from VSUP and a small current source keeps the LIN pin in the recessive state. The receiver is still active and able to detect wake-up events on the LIN bus line.

A dominant level longer than  $T_{PROPWL}$  followed by a rising edge will generate a wake-up interrupt, and will be reported in the Interrupt Source Register (ISR). Also see [Figure 34](#).

**SLEEP Mode And Wake-up Feature**

During Sleep mode operation, the transmitter of the physical layer is disabled. If the LIN-PU bit was set in the Sleep mode sequence, the internal pull-up resistor is disconnected from  $V_{SUP}$  and a small current source keeps the LIN pin in recessive state. The receiver must be active to detect wake-up events on the LIN bus line.

A dominant level longer than  $T_{PROPWL}$  followed by a rising edge will generate a system wake-up (Reset), and will be reported in the Interrupt Source Register (ISR). Also see [Figure 33](#).



## LOGIC COMMANDS AND REGISTERS

## 33912 SPI INTERFACE AND CONFIGURATION

The serial peripheral interface creates the communication link between a microcontroller (master) and the 33912.

The interface consists of four pins (see [Figure 43](#)):

- $\overline{CS}$ —Chip Select
- MOSI—Master-Out Slave-In

- MISO—Master-In Slave-Out
- SCLK—Serial Clock

A complete data transfer via the SPI consists of 1 byte. The master sends 4 bits of address (A3:A0) + 4 bits of control information (C3:C0) and the slave replies with 4 system status bits (VMS,LINS,HSS,LSS) + 4 bits of status information (S3:S0).

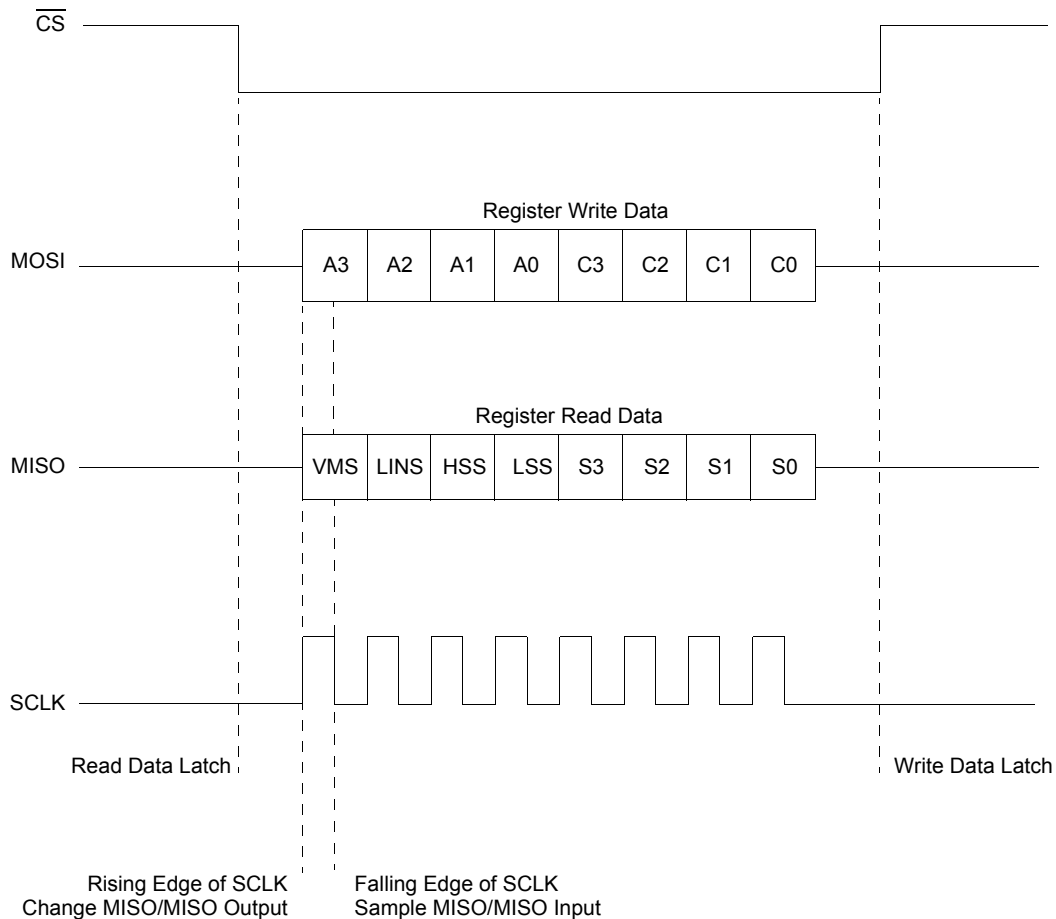

**Figure 43. SPI Protocol**

During the inactive phase of the  $\overline{CS}$  (HIGH), the new data transfer is prepared.

The falling edge of the  $\overline{CS}$  indicates the start of a new data transfer and puts the MISO in the low-impedance state and latches the analog status data (Register read data).

With the rising edge of the SPI clock (SCLK), the data is moved to MISO/MOSI pins. With the falling edge of the SPI clock (SCLK), the data is sampled by the receiver.

The data transfer is only valid if exactly 8 sample clock edges are present during the active (low) phase of  $\overline{CS}$ .

The rising edge of the Chip Select  $\overline{CS}$  indicates the end of the transfer and latches the write data (MOSI) into the register. The  $\overline{CS}$  high forces MISO to the high impedance state.

Register reset values are described along with the reset condition. Reset condition is the condition causing the bit to be set to its reset value. The main reset conditions are:

- Power-On Reset (POR): the level at which the logic is reset and BATFAIL flag sets.
- Reset mode
- Reset done by the  $\overline{RST}$  pin (ext\_reset)

## SPI REGISTER OVERVIEW

Table 38. System Status Register

Address(A3:A0)	Register Name / Read/Write Information		BIT			
			7	6	5	4
\$0 - \$F	SYSSR - System Status Register	R	VMS	LINS	HSS	LSS

Table 39 summarizes the SPI Register content for Control Information (C3:C0)=W and status information (S3:S0) = R.

Table 39. SPI Register Overview

Address(A3:A0)	Register Name / Read/Write Information		BIT			
			3	2	1	0
\$0	MCR - Mode Control Register	W	HVSE	LINPE	MOD2	MOD1
	VSR - Voltage Status Register	R	VSOV	VSUV	VDDOT	BATFAIL
\$1	VSR - Voltage Status Register	R	VSOV	VSUV	VDDOT	BATFAIL
\$2	WUCR - Wake-up Control Register	W	L4WE	L3WE	L2WE	L1WE
	WUSR - Wake-up Status Register	R	L4	L3	L2	L1
\$3	WUSR - Wake-up Status Register	R	L4	L3	L2	L1
\$4	LINCR - LIN Control Register	W	LDVS	RXONLY	LSR1	LSR0
	LINSR - LIN Status Register	R	RXSHORT	TXDOM	LINOT	LINOC
\$5	LINSR - LIN Status Register	R	RXSHORT	TXDOM	LINOT	LINOC
\$6	HSCR - High Side Control Register	W	PWMHS2	PWMHS1	HS2	HS1
	HSSR - High Side Status Register	R	HS2OP	HS2CL	HS1OP	HS1CL
\$7	HSSR - High Side Status Register	R	HS2OP	HS2CL	HS1OP	HS1CL
\$8	LSCR - Low Side Control Register	W	PWMLS2	PWMLS1	LS2	LS1
	LSSR - Low Side Status Register	R	LS2OP	LS2CL	LS1OP	LS1CL
\$9	LSSR - Low Side Status Register	R	LS2OP	LS2CL	LS1OP	LS1CL
\$A	TIMCR - Timing Control Register	W	CS/WD	WD2	WD1	WD0
	WDSR - Watchdog Status Register	R		WDTO	WDERR	WDOFF
\$B	WDSR - Watchdog Status Register	R	WDTO	WDERR	WDOFF	WDWO
\$C	AMUXCR - Analog Multiplexer Control Register	W	LXDS	MX2	MX1	MX0
\$D	CFR - Configuration Register	W	HVDD	CYSX8	CSAZ	CSGS
\$E	IMR - Interrupt Mask Register	W	HSM	LSM	LINM	VMM
	ISR - Interrupt Source Register	R	ISR3	ISR2	ISR1	ISR0
\$F	ISR - Interrupt Source Register	R	ISR3	ISR2	ISR1	ISR0

## REGISTER DEFINITIONS

## System Status Register - SYSSR

The System Status Register (SYSSR) is always transferred with every SPI transmission and gives a quick system status overview. It summarizes the status of the Voltage Status Register (VSR), LIN Status Register (LINSR), High Side Status Register (HSSR), and the Low Side Status Register (LSSR).

Table 40. System Status Register

	S7	S6	S5	S4
Read	VMS	LINS	HSS	LSS

## VMS - Voltage Monitor Status

This read-only bit indicates that one or more bits in the VSR are set.

1 = Voltage Monitor bit set

0 = None

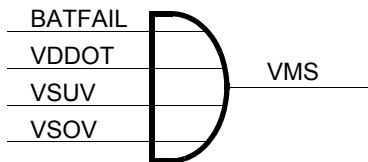

Figure 44. Voltage Monitor Status

## LINS - LIN Status

This read-only bit indicates that one or more bits in the LINSR are set.

1 = LIN Status bit set

0 = None

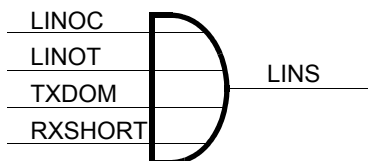

Figure 45. LIN Status

## HSS - High Side Switch Status

This read-only bit indicates that one or more bits in the HSSR are set.

1 = High Side Status bit set

0 = None

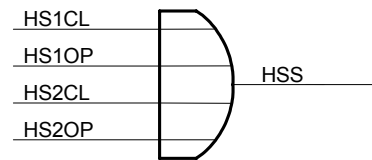

Figure 46. High Side Status

## LSS - Low Side Switch Status

This read-only bit indicates that one or more bits in the LSSR are set.

1 = Low Side Status bit set

0 = None

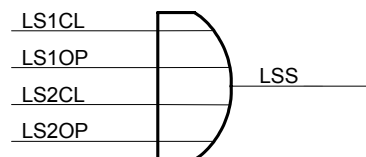

Figure 47. Low Side Status

## Mode Control Register - MCR

The Mode Control Register (MCR) allows switching between the operation modes and to configure the 33912. Writing the MCR will return the VSR.

Table 41. Mode Control Register - \$0

	C3	C2	C1	C0
Write	HVSE	LINPE	MOD2	MOD1
Reset Value	1	1	-	-
Reset Condition	POR	POR	-	-

## HVSE - High-voltage Shutdown Enable

This write-only bit enables/disables automatic shutdown of the high side and the low side drivers during a high-voltage VSOV condition.

1 = automatic shutdown enabled

0 = automatic shutdown disabled

## LINPE - LIN pull-up enable.

This write-only bit enables/disables the 30 kΩ LIN pull-up resistor in STOP and SLEEP modes. This bit also controls the LIN bus wake-up threshold.

1 = LIN pull-up resistor enabled

0 = LIN pull-up resistor disabled

**MOD2, MOD1 - Mode Control Bits**

These write-only bits select the operating mode and allow clearing the watchdog in accordance with [Table 82](#) Mode Control Bits.

**Table 42. Mode Control Bits**

MOD2	MOD1	Description
0	0	Normal Mode
0	1	Stop Mode
1	0	Sleep Mode
1	1	Normal Mode + Watchdog Clear

**Voltage Status Register - VSR**

Returns the status of the several voltage monitors. This register is also returned when writing to the Mode Control Register (MCR).

**Table 43. Voltage Status Register - \$0/\$1**

	S3	S2	S1	S0
Read	VSOV	VSUV	VDDOT	BATFAIL

**VSOV -  $V_{SUP}$  Over-voltage**

This read-only bit indicates an over-voltage condition on the VS1 pin.

- 1 = Over-voltage condition.
- 0 = Normal condition.

**VSUV -  $V_{SUP}$  Under-Voltage**

This read-only bit indicates an under-voltage condition on the VS1 pin.

- 1 = Under-voltage condition.
- 0 = Normal condition.

**VDDOT - Main Voltage Regulator Over-temperature Warning**

This read-only bit indicates that the main voltage regulator temperature reached the Over-temperature Prewarning Threshold.

- 1 = Over-temperature Prewarning
- 0 = Normal

**BATFAIL - Battery Fail Flag.**

This read-only bit is set during power-up and indicates that the 33912 had a Power-On-Reset (POR).

Any access to the MCR or VSR will clear the BATFAIL flag.

- 1 = POR Reset has occurred
- 0 = POR Reset has not occurred

**Wake-up Control Register - WUCR**

This register is used to control the digital wake-up inputs. Writing the WUCR will return the Wake-up Status Register (WUSR).

**Table 44. Wake-up Control Register - \$2**

	C3	C2	C1	C0
Write	L4WE	L3WE	L2WE	L1WE
Reset Value	1	1	1	1
Reset Condition	POR, Reset mode or ext_reset			

**LxWE - Wake-up Input x Enable**

This write-only bit enables/disables which Lx inputs are enabled. In Stop and Sleep mode the LxWE bit determines which wake inputs are active for wake-up. If one of the Lx inputs is selected on the analog multiplexer, the corresponding LxWE is masked to 0.

- 1 = Wake-Up Input x enabled.
- 0 = Wake-Up Input x disabled.

**Wake-up Status Register - WUSR**

This register is used to monitor the digital wake-up inputs and is also returned when writing to the WUCR.

**Table 45. Wake-up Status Register - \$2/\$3**

	S3	S2	S1	S0
Read	L4	L3	L2	L1

**Lx - Wake-up input x**

This read-only bit indicates the status of the corresponding Lx input. If the Lx input is not enabled, then the according Wake-Up status will return 0.

After a wake-up from Stop or Sleep mode these bits also allow to determine which input has caused the wake-up, by first reading the Interrupt Status Register (ISR) and then reading the WUSR.

- 1 = Lx Wake-up.
- 0 = Lx Wake-up disabled or selected as analog input.

**LIN Control Register - LINCRCR**

This register controls the LIN physical interface block. Writing the LIN Control Register (LINCRCR) returns the LIN Status Register (LINSR).

**Table 46. LIN Control Register - \$4**

	C3	C2	C1	C0
Write	LDVS	RXONLY	LSR1	LSR0
Reset Value	0	0	0	0
Reset Condition	POR, Reset mode or ext_reset	POR, Reset mode, ext_reset or LIN failure gone*	POR	

\* LIN failure gone: if LIN failure (over-temp, TXD/RXD short) was set, the flag resets automatically when the failure is gone.

**LDVS - LIN Dominant Voltage Select**

This write-only bit controls the LIN Dominant voltage:

1 = LIN Dominant Voltage =  $V_{LIN\_DOM\_1}$  (1.7V typ)

0 = LIN Dominant Voltage =  $V_{LIN\_DOM\_0}$  (1.1V typ)

**RXONLY - LIN Receiver Operation Only**

This write-only bit controls the behavior of the LIN transmitter.

In Normal mode, the activation of the RXONLY bit disables the LIN transmitter. In case of a LIN error condition, this bit is automatically set.

In Stop mode this bit disables the LIN wake-up functionality, and the RXD pin will reflect the state of the LIN bus.

1 = only LIN receiver active (Normal mode) or LIN wake-up disabled (Stop mode).

0 = LIN fully enabled.

**LSRx - LIN Slew-Rate**

This write-only bit controls the LIN driver slew-rate in accordance with [Table 47](#).

**Table 47. LIN Slew-Rate Control**

LSR1	LSR0	Description
0	0	Normal Slew Rate (up to 20kb/s)
0	1	Slow Slew Rate (up to 10kb/s)
1	0	Fast Slew Rate (up to 100kb/s)
1	1	Reserved

**LIN Status Register - LINSR**

This register returns the status of the LIN physical interface block and is also returned when writing to the LINCRCR.

**Table 48. LIN Status Register - \$4/\$5**

	S3	S2	S1	S0
Read	RXSHORT	TXDOM	LINOT	LINOC

**RXSHORT - RXD Pin Short-circuit**

This read-only bit indicates a short-circuit condition on the RXD pin (shorted either to 5.0 V or to Ground). The short-circuit delay must be a worst case of 8 $\mu$ s to be detected and to shut down the driver. To clear this bit, it must be read after the condition is gone (transition detected on RXD pin). The LIN driver is automatically re-enabled once the condition is gone.

1 = RXD short-circuit condition.

0 = None.

**TXDOM - TXD Permanent Dominant**

This read-only bit signals the detection of a TXD pin stuck at dominant (Ground) condition and the resultant shutdown in the LIN transmitter. This condition is detected after the TXD pin remains in dominant state for more than 1 second (typical value).

To clear this bit, it must be read after TXD has gone high. The LIN driver is automatically re-enabled once TXD goes High.

1 = TXD stuck at dominant fault detected.

0 = None.

**LINOT - LIN Driver Over-temperature Shutdown**

This read-only bit signals that the LIN transceiver was shutdown due to over-temperature. The transmitter is automatically re-enabled after the over-temperature condition is gone and TXD is high. The LINOT bit is cleared after SPI read once the condition is gone.

1 = LIN over-temperature shutdown

0 = None

**LINOC - LIN Driver Over-Current Shutdown**

This read-only bit signals an over-current condition occurred on the LIN pin. The LIN driver is not shut down but an IRQ is generated. To clear this bit, it must be read after the condition is gone.

1 = LIN over-current shutdown

0 = None

**High Side Control Register - HSCR**

This register controls the operation of the high side drivers. Writing to this register returns the High Side Status Register (HSSR).

**Table 49. High Side Control Register - \$6**

	C3	C2	C1	C0
Write	PWMHS2	PWMHS1	HS2	HS1
Reset Value	0	0	0	0
Reset Condition	POR		POR, Reset mode, ext_reset, HSx over-temp or (VSOV & HVSE)	

**PWMHSx - PWM Input Control Enable.**

This write-only bit enables/disables the PWMIN input pin to control the respective high side switch. The corresponding high side switch must be enabled (HSx bit).

1 = PWMIN input controls HSx output.

0 = HSx is controlled only by SPI.

**HSx - HSx Switch Control.**

This write-only bit enables/disables the corresponding high side switch.

1 = HSx switch on.

0 = HSx switch off.

**High Side Status Register - HSSR**

This register returns the status of the high side switches and is also returned when writing to the HSCR.

**Table 50. High Side Status Register - \$6/\$7**

	S3	S2	S1	S0
Read	HS2OP	HS2CL	HS1OP	HS1CL

**High Side Thermal Shutdown**

A thermal shutdown of the high side drivers is indicated by setting all HSxOP and HSxCL bits simultaneously.

**HSxOP - High Side Switch Open-Load Detection**

This read-only bit signals that the high side switches are conducting current below a certain threshold indicating possible load disconnection.

1 = HSx Open Load detected (or thermal shutdown)

0 = Normal

**HSxCL - High Side Current Limitation**

This read-only bit indicates that the respective high side switch is operating in current limitation mode.

1 = HSx in current limitation (or thermal shutdown)

0 = Normal

**Low Side Control Register - LSCR**

This register controls the operation of the low side drivers. Writing the Low Side Control Register (LSCR) will also return the Low Side Status Register (LSSR).

**Table 51. Low Side Control Register - \$8**

	C3	C2	C1	C0
Write	PWMLS2	PWMLS1	LS2	LS1
Reset Value	0	0	0	0
Reset Condition	POR		POR, Reset mode, ext_reset, LSx over-temp or (VSOV & HVSE)	

**PWMLx - PWM input control enable.**

This write-only bit enables/disables the PWMIN input pin to control the respective low side switch. The corresponding low side switch must be enabled (LSx bit).

1 = PWMIN input controls LSx.

0 = LSx is controlled only by SPI.

**LSx - LSx switch control.**

This write-only bit enables/disables the corresponding low side switch.

1 = LSx switch on.

0 = LSx switch off.

**Low Side Status Register - LSSR**

This register returns the status of the low side switches and is also returned when writing to the LSCR.

**Table 52. Low Side Status Register - \$8/\$9**

	C3	C2	C1	C0
Read	LS2OP	LS2CL	LS1OP	LS1CL

**Low Side Thermal Shutdown**

A thermal shutdown of the low side drivers is indicated by setting all LSxOP and LSxCL bits simultaneously.

**LSxOP - Low Side Switch Open-Load Detection**

This read-only bit signals that the low side switches are conducting current below a certain threshold indicating possible load disconnection.

1 = LSx Open Load detected (or thermal shutdown)

0 = Normal

**LSxCL - Low Side Current Limitation**

This read-only bit indicates that the respective low side switch is operating in current limitation mode.

1 = LSx in current limitation (or thermal shutdown)

0 = Normal

**Timing Control Register - TIMCR**

This register is a double purpose register which allows to configure the watchdog and the cyclic sense periods. Writing to the Timing Control Register (TIMCR) will also return the Watchdog Status Register (WDSR).

**Table 53. Timing Control Register - \$A**

	C3	C2	C1	C0
Write	CS/WD	WD2	WD1	WD0
		CYST2	CYST1	CYST0
Reset Value	-	0	0	0
Reset Condition	-	POR		

**CS/WD - Cyclic Sense or Watchdog prescaler select**

This write-only bit selects which prescaler is being written to, the Cyclic Sense prescaler or the Watchdog prescaler.

1 = Cyclic Sense Prescaler selected

0 = Watchdog Prescaler select

**WDx - Watchdog Prescaler**

This write-only bits selects the divider for the watchdog prescaler and therefore selects the watchdog period in accordance with [Table 54](#). This configuration is valid only if windowing watchdog is active.

**Table 54. Watchdog Prescaler**

WD2	WD1	WD0	Prescaler Divider
0	0	0	1
0	0	1	2
0	1	0	4
0	1	1	6
1	0	0	8
1	0	1	10
1	1	0	12
1	1	1	14

**CYSTx - Cyclic Sense Period Prescaler Select**

This write-only bits selects the interval for the wake-up cyclic sensing together with the bit CYSX8 in the Configuration Register (CFR) (see [Configuration Register - CFR](#)).

This option is only active if one of the high side switches is enabled when entering in Stop or Sleep mode. Otherwise a timed wake-up is performed after the period shown in [Table 55](#).

**Table 55. Cyclic Sense Interval**

CYSX8 <sup>(132)</sup>	CYST2	CYST1	CYST0	Interval
X	0	0	0	No cyclic sense
0	0	0	1	20 ms
0	0	1	0	40 ms
0	0	1	1	60 ms
0	1	0	0	80 ms
0	1	0	1	100 ms
0	1	1	0	120 ms
0	1	1	1	140 ms
1	0	0	1	160 ms
1	0	1	0	320 ms
1	0	1	1	480 ms
1	1	0	0	640 ms
1	1	0	1	800 ms
1	1	1	0	960 ms
1	1	1	1	1120 ms

Notes

132. bit CYSX8 is located in Configuration Register (CFR)

**Watchdog Status Register - WDSR**

This register returns the Watchdog status information and is also returned when writing to the TIMCR.

**Table 56. Watchdog Status Register - \$A/\$B**

	S3	S2	S1	S0
Read	WDTO	WDERR	WDOFF	WDWO

**WDTO - Watchdog Timeout**

This read-only bit signals the last reset was caused by either a watchdog timeout or by an attempt to clear the Watchdog within the window closed.

Any access to this register or the Timing Control Register (TIMCR) will clear the WDTO bit.

1 = Last reset caused by watchdog timeout

0 = None



**WDERR - Watchdog Error**

This read-only bit signals the detection of a missing watchdog resistor. In this condition the watchdog is using the internal, lower precision timebase. The Windowing function is disabled.

1 = WDCONF pin resistor missing

0 = WDCONF pin resistor not floating

**WDOFF - Watchdog Off**

This read-only bit signals that the watchdog pin connected to Ground and therefore disabled. In this case watchdog timeouts are disabled and the device automatically enters Normal mode out of Reset. This might be necessary for software debugging and for programming the Flash memory.

1 = Watchdog is disabled

0 = Watchdog is enabled

**WDWO - Watchdog Window Open**

This read-only bit signals when the watchdog window is open for clears. The purpose of this bit is for testing. Should be ignored in case WDERR is High.

1 = Watchdog window open

0 = Watchdog window closed

**Analog Multiplexer Control Register - MUXCR**

This register controls the analog multiplexer and selects the divider ration for the Lx input divider.

**Table 57. Analog Multiplexer Control Register - \$C**

	C3	C2	C1	C0
Write	LXDS	MX2	MX1	MX0
Reset Value	1	0	0	0
Reset Condition	POR	POR, Reset mode or ext_reset		

**LXDS - Lx Analog Input Divider Select**

This write-only bit selects the resistor divider for the Lx analog inputs. Voltage is internally clamped to VDD.

0 = Lx Analog divider: 1

1 = Lx Analog divider: 3.6 (typ.)

**MXx - Analog Multiplexer Input Select**

These write-only bits selects which analog input is multiplexed to the ADOUT0 pin according to [Table 58](#).

When disabled or when in Stop or Sleep mode, the output buffer is not powered and the ADOUT0 output is left floating to achieve lower current consumption.

**Table 58. Analog Multiplexer Channel Select**

MX2	MX1	MX0	Meaning
0	0	0	Disabled
0	0	1	Reserved
0	1	0	Die Temperature Sensor
0	1	1	VSENSE input
1	0	0	L1 input
1	0	1	L2 input
1	1	0	L3 input
1	1	1	L4 input

**Configuration Register - CFR**

This register controls the Hall Sensor Supply enable/disable, the cyclic sense timing multiplier, enables/disables the Current Sense Auto-zero function and selects the gain for the current sense amplifier.

**Table 59. Configuration Register - \$D**

	C3	C2	C1	C0
Write	HVDD	CYSX8	CSAZ	CSGS
Reset Value	0	0	0	0
Reset Condition	POR, Reset mode or ext_reset	POR	POR	POR

**HVDD - Hall Sensor Supply Enable**

This write-only bit enables/disables the state of the hall sensor supply.

1 = HVDD on

0 = HVDD off

**CYSX8 - Cyclic Sense Timing x 8.**

This write-only bit influences the cyclic sense period as shown in [Table 55](#).

1 = Multiplier enabled

0 = None

**CSAZ - Current Sense Auto-Zero Function Enable**

This write-only bit enables/disables the circuitry to lower the offset voltage of the current sense amplifier.

1 = Auto-zero function enabled

0 = Auto-zero function disabled

**CSGS - Current Sense Amplifier Gain Select**

This write-only bit selects the gain of the current sense amplifier.

1 = 14.5 (typ.)

0 = 30 (typ.)



**Interrupt Mask Register - IMR**

This register allows masking of some of the interrupt sources. The respective flags within the Interrupt Source Register (ISR) will continue to work but will not generate interrupts to the MCU. The 5.0 V Regulator over-temperature prewarning interrupt and Under-Voltage (VSUV) interrupts can not be masked and will always cause an interrupt.

Writing to the IMR will return the ISR.

**Table 60. Interrupt Mask Register - \$E**

	C3	C2	C1	C0
Write	HSM	LSM	LINM	VMM
Reset Value	1	1	1	1
Reset Condition	POR			

**HSM - High Side Interrupt Mask**

This write-only bit enables/disables interrupts generated in the high side block.

1 = HS Interrupts Enabled

0 = HS Interrupts Disabled

**LSM - Low Side Interrupt Mask**

This write-only bit enables/disables interrupts generated in the low side block.

1 = LS Interrupts Enabled

0 = LS Interrupts Disabled

**LINM - LIN Interrupts Mask**

This write-only bit enables/disables interrupts generated in the LIN block.

1 = LIN Interrupts Enabled

0 = LIN Interrupts Disabled

**VMM - Voltage Monitor Interrupt Mask**

This write-only bit enables/disables interrupts generated in the Voltage Monitor block. The only maskable interrupt in the Voltage Monitor Block is the V<sub>SUP</sub> over-voltage interrupt.

1 = Interrupts Enabled

0 = Interrupts Disabled

**Interrupt Source Register - ISR**

This register allows the MCU to determine the source of the last interrupt or wake-up respectively. A read of the register acknowledges the interrupt and leads  $\overline{IRQ}$  pin to high, in case there are no other pending interrupts. If there are pending interrupts,  $\overline{IRQ}$  will be driven high for 10  $\mu$ s and then be driven low again.

This register is also returned when writing to the Interrupt Mask Register (IMR).

**Table 61. Interrupt Source Register - \$E/\$F**

	S3	S2	S1	S0
Read	ISR3	ISR2	ISR1	ISR0

**ISR<sub>x</sub> - Interrupt Source Register**

These read-only bits indicate the interrupt source following [Table 62](#). If no interrupt is pending then all bits are 0.

In case more than one interrupt is pending, the interrupt sources are handled sequentially multiplex.

**Table 62. Interrupt Sources**

				Interrupt Source		Priority
ISR3	ISR2	ISR1	ISR0	none maskable	maskable	
0	0	0	0	no interrupt	no interrupt	none
0	0	0	1		Lx Wake-up from Stop mode-	highest
0	0	1	0	-	HS Interrupt (Over-temperature)	
0	0	1	1	-	LS Interrupt (Over-temperature)	
0	1	0	0		LIN Interrupt (RXSHORT, TXDOM, LIN OT, LIN OC) or LIN Wake-up	
0	1	0	1	Voltage Monitor Interrupt (Low Voltage and VDD over-temperature)	Voltage Monitor Interrupt (High Voltage)	
0	1	1	0	-	Forced Wake-up	lowest



## PACKAGING

### PACKAGE DIMENSIONS

**Important** For the most current revision of the package, visit [www.Freescale.com](http://www.Freescale.com) and select Documentation, then under Available Documentation column select Packaging Information.

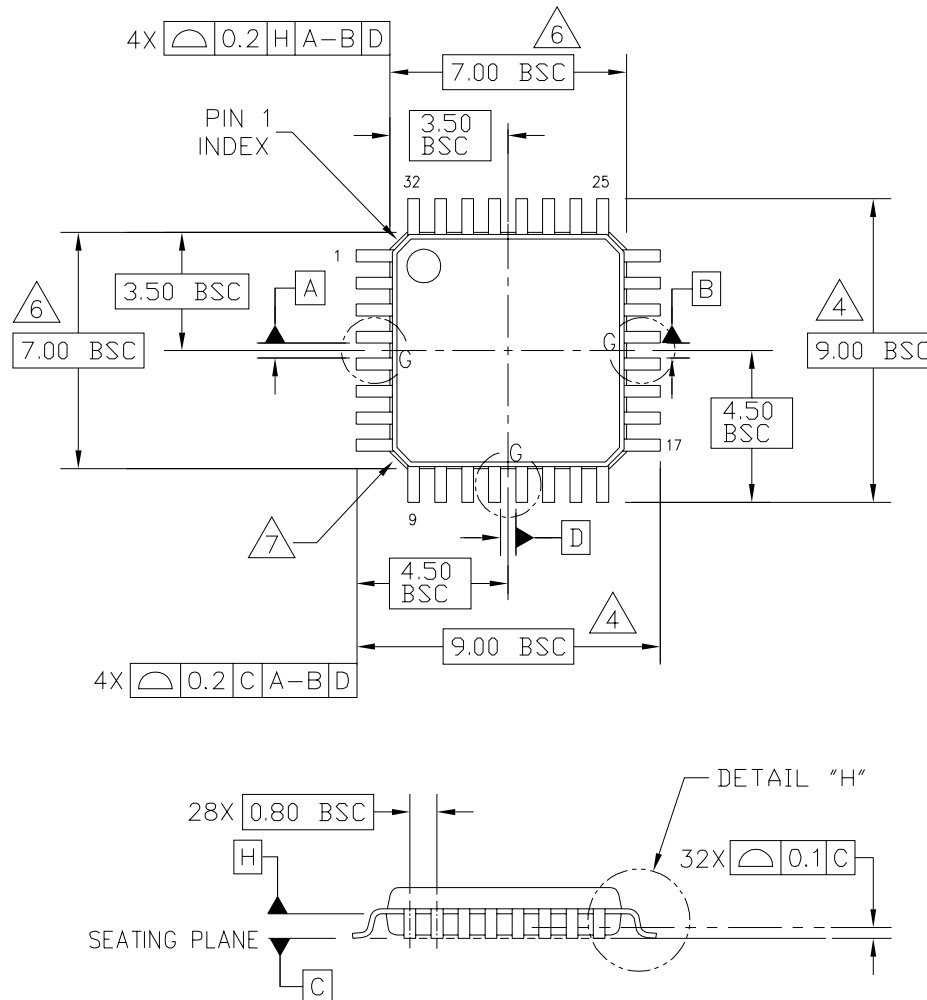

© FREESCALE SEMICONDUCTOR, INC. ALL RIGHTS RESERVED.	MECHANICAL OUTLINE	PRINT VERSION NOT TO SCALE	
TITLE: LOW PROFILE QUAD FLAT PACK (LQFP) 32 LEAD, 0.8 PITCH (7 X 7 X 1.4)	DOCUMENT NO: 98ASH70029A	REV: D	19 MAY 2005
	CASE NUMBER: 873A-03		
	STANDARD: JEDEC MS-026 BBA		

**AC SUFFIX (PB-FREE)**  
32-PIN LQFP  
98ASH70029A  
REVISION D

**PACKAGE DIMENSIONS (Continued)**

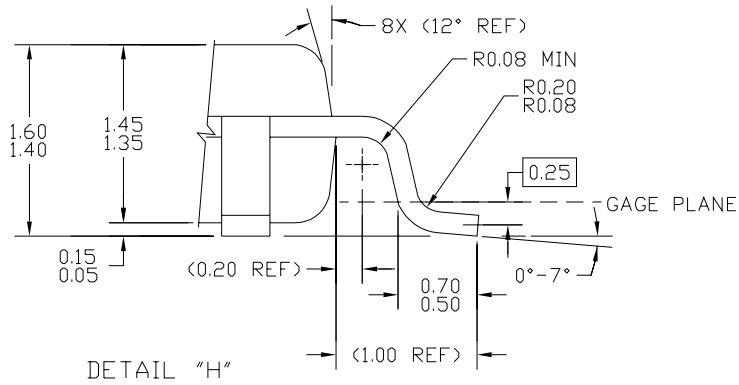
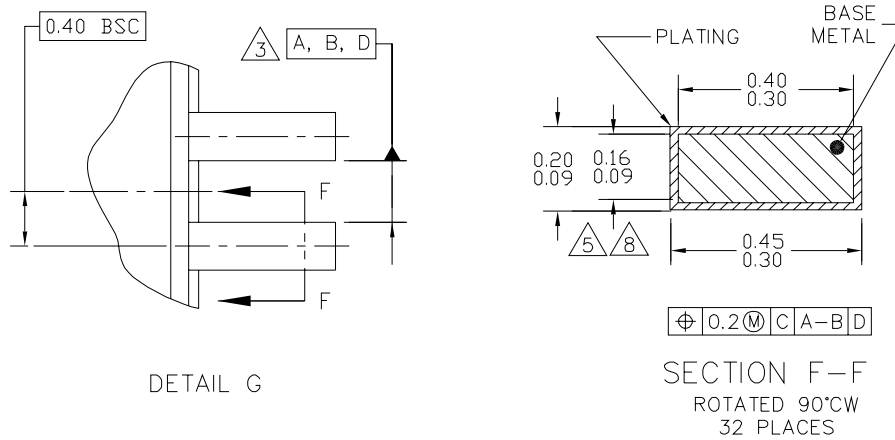

© FREESCALE SEMICONDUCTOR, INC. ALL RIGHTS RESERVED.	MECHANICAL OUTLINE	PRINT VERSION NOT TO SCALE	
TITLE: LOW PROFILE QUAD FLAT PACK (LQFP) 32 LEAD, 0.8 PITCH (7 X 7 X 1.4)	DOCUMENT NO: 98ASH70029A	REV: D	
	CASE NUMBER: 873A-03	19 MAY 2005	
	STANDARD: JEDEC MS-026 BBA		

**AC SUFFIX (PB-FREE)**  
32-PIN LQFP  
98ASH70029A  
REVISION D

## REVISION HISTORY

Revision	Date	Description of Changes
1.0	5/2007	<ul style="list-style-type: none"> <li>Initial Release</li> </ul>
2.0	9/2007	<ul style="list-style-type: none"> <li>Several textual corrections</li> <li>Page 11: "Analog Output offset Ratio" (LXDS=1) changed to "Analog Output offset" +/-22mV</li> <li>Page 11: VSENSE Input Divider Ratio adjusted to 5,0/5,25/5,5</li> <li>Page 12: Common mode input impedance corrected to 75k<math>\Omega</math></li> <li>Page 13/15: LIN PHYSICAL LAYER parameters adjusted to final LIN specification release</li> </ul>
3.0	9/2007	<ul style="list-style-type: none"> <li>Revision number incremented at engineering request.</li> </ul>
4.0	2/2008	<ul style="list-style-type: none"> <li>Changed Functional Block Diagram on page 24.</li> <li>This Data Sheet and previous versions cover Part Numbers MC33912BAC and MC34912BAC. Future revisions do not cover these Part Numbers.</li> </ul>
5.0	10/2008	<ul style="list-style-type: none"> <li>Datasheet updated according to the Pass1.2 silicon version electrical parameters</li> <li>Add Maximum Rating on I<sub>BUS_NO_GND</sub> parameter</li> <li>Added L1, L2, L3, and L4, Temperature Sense Analog Output Voltage per characterization<sup>(39)</sup>, Internal Chip Temperature Sense Gain per characterization at 3 temperatures<sup>(39)</sup> See Figure 16, Temperature Sense Gain, VSENSE Input Divider Ratio (RATIOVSENSE=VSENSE/VADOUT0) per characterization<sup>(40)</sup>, and VSENSE Output Related Offset per characterization<sup>(40)</sup> parameters</li> <li>Added Temperature Sense Gain section</li> <li>Minor corrections to ESD Capability, <sup>(18)</sup>, Cyclic Sense ON Time from Stop and Sleep mode<sup>(50)</sup>, Lin Bus Pin (LIN), Serial Data Clock Pin (SCLK), Master Out Slave In Pin (MOSI), Master In Slave Out Pin (MISO), Low Side Pins (LS1 and LS2), Digital/analog Pins (L1, L2, L3 and L4), Normal Request Mode, Sleep Mode, LIN Over-temperature Shutdown / TXD Stuck At Dominant / RXD Short-circuit, Fault Detection Management Conditions, Lin Physical Layer, LIN Interface, Over-temperature Shutdown (LIN Interrupt), LIN Receiver Operation Only, SPI Protocol, Lx - Wake-up input x, LIN Control Register - LINCR, and RXSHORT - RXD Pin Short-circuit</li> <li>This data sheet does not contain electrical parameters for MC33912BAC and MC34912BAC (see revision 4.0).</li> <li>Updated Freescale form and style</li> </ul>
6.0	2/2009	<ul style="list-style-type: none"> <li>Added explanation for pins Not Connected (NC).</li> <li>This data sheet does not contain electrical parameters for MC33912BAC and MC34912BAC (see revision 4.0).</li> </ul>
7.0	3/2009	<ul style="list-style-type: none"> <li>Changed VBAT_SHIFT and GND_SHIFT maximum from 10% to 11.5% for both parameters on page 14.</li> <li>This data sheet does not contain electrical parameters for MC33912BAC and MC34912BAC (see revision 4.0).</li> </ul>
8.0	3/2010	<ul style="list-style-type: none"> <li>Combined Complete Data sheet for Part Numbers MC33912BAC and MC34912BAC to the back of this data sheet.</li> <li>Changed ESD Voltage for Machine Model from <math>\pm 200</math> to <math>\pm 150</math></li> </ul>

## **How to Reach Us:**

### **Home Page:**

[www.freescale.com](http://www.freescale.com)

### **Web Support:**

<http://www.freescale.com/support>

### **USA/Europe or Locations Not Listed:**

Freescale Semiconductor, Inc.  
Technical Information Center, EL516  
2100 East Elliot Road  
Tempe, Arizona 85284  
1-800-521-6274 or +1-480-768-2130  
[www.freescale.com/support](http://www.freescale.com/support)

### **Europe, Middle East, and Africa:**

Freescale Halbleiter Deutschland GmbH  
Technical Information Center  
Schatzbogen 7  
81829 Muenchen, Germany  
+44 1296 380 456 (English)  
+46 8 52200080 (English)  
+49 89 92103 559 (German)  
+33 1 69 35 48 48 (French)  
[www.freescale.com/support](http://www.freescale.com/support)

### **Japan:**

Freescale Semiconductor Japan Ltd.  
Headquarters  
ARCO Tower 15F  
1-8-1, Shimo-Meguro, Meguro-ku,  
Tokyo 153-0064  
Japan  
0120 191014 or +81 3 5437 9125  
[support.japan@freescale.com](mailto:support.japan@freescale.com)

### **Asia/Pacific:**

Freescale Semiconductor China Ltd.  
Exchange Building 23F  
No. 118 Jianguo Road  
Chaoyang District  
Beijing 100022  
China  
+86 10 5879 8000  
[support.asia@freescale.com](mailto:support.asia@freescale.com)

### **For Literature Requests Only:**

Freescale Semiconductor Literature Distribution Center  
P.O. Box 5405  
Denver, Colorado 80217  
1-800-441-2447 or +1-303-675-2140  
Fax: +1-303-675-2150  
[LDCForFreescaleSemiconductor@hibbertgroup.com](mailto:LDCForFreescaleSemiconductor@hibbertgroup.com)

Information in this document is provided solely to enable system and software implementers to use Freescale Semiconductor products. There are no express or implied copyright licenses granted hereunder to design or fabricate any integrated circuits or integrated circuits based on the information in this document.

Freescale Semiconductor reserves the right to make changes without further notice to any products herein. Freescale Semiconductor makes no warranty, representation or guarantee regarding the suitability of its products for any particular purpose, nor does Freescale Semiconductor assume any liability arising out of the application or use of any product or circuit, and specifically disclaims any and all liability, including without limitation consequential or incidental damages. "Typical" parameters that may be provided in Freescale Semiconductor data sheets and/or specifications can and do vary in different applications and actual performance may vary over time. All operating parameters, including "Typicals", must be validated for each customer application by customer's technical experts. Freescale Semiconductor does not convey any license under its patent rights nor the rights of others. Freescale Semiconductor products are not designed, intended, or authorized for use as components in systems intended for surgical implant into the body, or other applications intended to support or sustain life, or for any other application in which the failure of the Freescale Semiconductor product could create a situation where personal injury or death may occur. Should Buyer purchase or use Freescale Semiconductor products for any such unintended or unauthorized application, Buyer shall indemnify and hold Freescale Semiconductor and its officers, employees, subsidiaries, affiliates, and distributors harmless against all claims, costs, damages, and expenses, and reasonable attorney fees arising out of, directly or indirectly, any claim of personal injury or death associated with such unintended or unauthorized use, even if such claim alleges that Freescale Semiconductor was negligent regarding the design or manufacture of the part.



Freescale™ and the Freescale logo are trademarks of Freescale Semiconductor, Inc. All other product or service names are the property of their respective owners.

© Freescale Semiconductor, Inc. 2009 - 2010. All rights reserved.