



# 3.0 A 1.0 MHz Fully Integrated DDR Switch-Mode Power Supply

The 34712 is a highly integrated, space efficient, low cost, single synchronous buck switching regulator with integrated N-channel power MOSFETs. It is a high performance point-of-load (PoL) power supply with the ability to track an external reference voltage.

Its high efficient 3.0 A sink and source capability combined with its voltage tracking/sequencing ability and tight output regulation, makes it ideal to provide the termination voltage ( $V_{TT}$ ) for modern data buses such as Double-Data-Rate (DDR) memory buses. It also provides a buffered output reference voltage ( $V_{REF}$ ) to the memory chipset

The 34712 offers the designer the flexibility of many control, supervisory, and protection functions to allow for easy implementation of complex designs. It is housed in a Pb-free, thermally enhanced, and space efficient 24 Pin Exposed Pad QFN.

### Features

- 50 mΩ integrated N-channel power MOSFETs
- Input voltage operating range from 3.0 to 6.0 V
- ±1% Accurate output voltage, ranging from 0.7 to 1.35 V
- ±1% Accurate buffered reference output voltage
- Programmable switching frequency range from 200 kHz to 1.0 MHz with a default of 1.0 MHz
- Over-current limit and short-circuit protection
- Thermal shutdown
- Output over-voltage and under-voltage detection
- Active low power good output signal
- Active low standby and shutdown inputs

34712

SWITCH-MODE POWER SUPPLY



ORDERING INFORMATION		
Device	Temperature Range ( $T_A$ )	Package
MC34712EP/R2	-40 to 85 °C	24 QFN

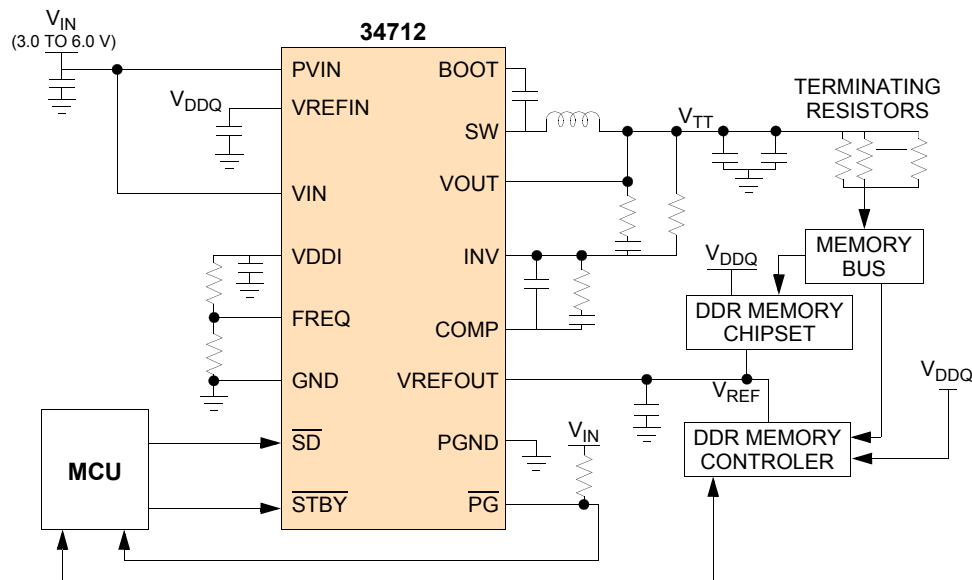

Figure 1. 34712 Simplified Application Diagram

\* This document contains certain information on a new product. Specifications and information herein are subject to change without notice.  
© Freescale Semiconductor, Inc., 2007-2012. All rights reserved.



### INTERNAL BLOCK DIAGRAM

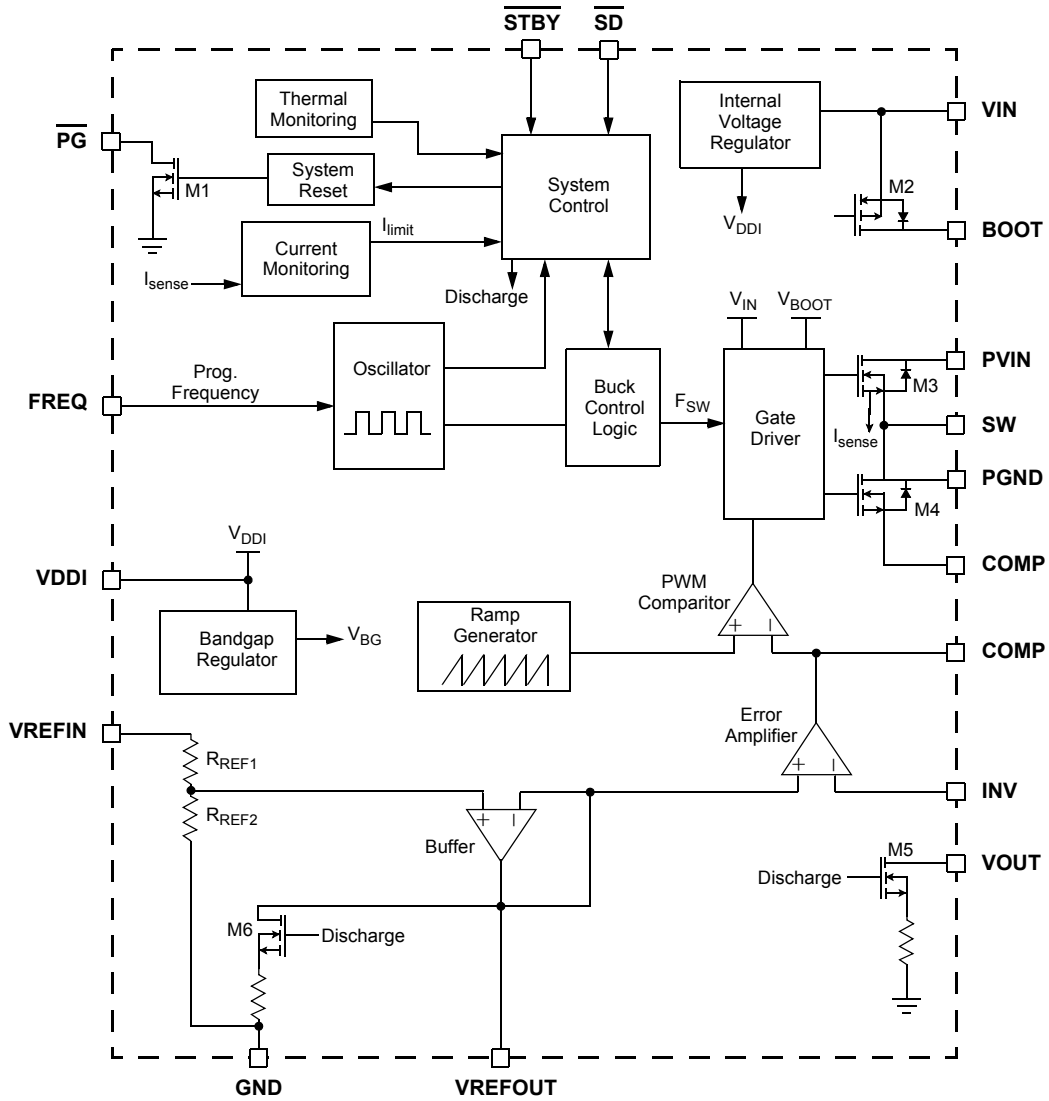

Figure 2. 34712 Simplified Internal Block Diagram

## PIN CONNECTIONS

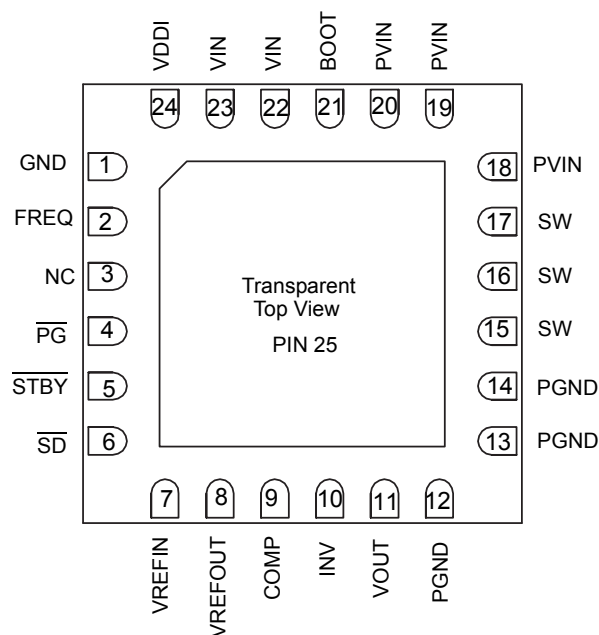

Figure 3. 34712 Pin Connections

Table 1. 34712 Pin Definitions

A functional description of each pin can be found in the Functional Pin Description section beginning on [page 10](#).

Pin Number	Pin Name	Pin Function	Formal Name	Definition
1	GND	Ground	Signal Ground	Analog signal ground of IC
2	FREQ	Passive	Frequency Adjustment	Buck converter switching frequency adjustment pin
3	NC	None	No Connect	No internal connections to this pin
4	$\overline{\text{PG}}$	Output	Power Good	Active-low (open drain) power-good status reporting pin
5	$\overline{\text{STBY}}$	Input	Standby	Standby mode input control pin
6	$\overline{\text{SD}}$	Input	Shutdown	Shutdown mode input control pin
7	VREFIN	Input	Voltage Tracking Reference Input	Voltage tracking reference voltage input
8	VREFOUT	Output	Reference Voltage Output	Buffered output equal to 1/2 of voltage-tracking reference
9	COMP	Passive	Compensation	Buck converter external compensation network pin
10	INV	Input	Error Amplifier Inverting Input	Buck converter error amplifier inverting input pin
11	VOUT	Output	Output Voltage Discharge FET	Discharge FET drain connection (connect to buck converter output capacitors)
12,13,14	PGND	Ground	Power Ground	Ground return for buck converter and discharge FET
15,16,17	SW	Output	Switching Node	Buck converter power switching node
18,19,20	PVIN	Supply	Power-circuit Supply Input	Buck converter main supply voltage input
21	BOOT	Passive	Bootstrap	Bootstrap switching node (connect to bootstrap capacitor)

**Table 1. 34712 Pin Definitions (continued)**

A functional description of each pin can be found in the Functional Pin Description section beginning on [page 10](#).

Pin Number	Pin Name	Pin Function	Formal Name	Definition
22,23	VIN	Supply	Logic-circuit Supply Input	Logic circuits supply voltage input
24	VDDI	Passive	Internal Voltage Regulator	Internal VDD Regulator (connect filter capacitor to this pin)
25	GND	Ground	Thermal Pad	Thermal pad for heat transfer. Connect the thermal pad to the analog ground and the ground plane for heat sinking.

## ELECTRICAL CHARACTERISTICS

## MAXIMUM RATINGS

**Table 2. Maximum Ratings**

All voltages are with respect to ground unless otherwise noted. Exceeding these ratings may cause a malfunction or permanent damage to the device.

Ratings	Symbol	Value	Unit
<b>ELECTRICAL RATINGS</b>			
Input Supply Voltage (VIN) Pin	$V_{IN}$	-0.3 to 7.0	V
High Side MOSFET Drain Voltage (PVIN) Pin	$PV_{IN}$	-0.3 to 7.0	V
Switching Node (SW) Pin	$V_{SW}$	-0.3 to 7.0	V
BOOT Pin (Referenced to SW Pin)	$V_{BOOT} - V_{SW}$	-0.3 to 7.0	V
$\overline{PG}$ , $\overline{VOUT}$ , $\overline{SD}$ , and $\overline{STBY}$ Pins	-	-0.3 to 7.0	V
VDDI, $\overline{FREQ}$ , $\overline{INV}$ , $\overline{COMP}$ , $\overline{VREFIN}$ , and $\overline{VREFOUT}$ Pins	-	-0.3 to 3.0	V
Continuous Output Current <sup>(1)</sup>	$I_{OUT}$	±3.0	A
ESD Voltage <sup>(2)</sup>			
Human Body Model	$V_{ESD1}$	±2000	V
Machine Model (MM)	$V_{ESD2}$	±200	
Device Charge Model (CDM)	$V_{ESD3}$	±750	
<b>THERMAL RATINGS</b>			
Operating Ambient Temperature <sup>(3)</sup>	$T_A$	-40 to 85	°C
Storage Temperature	$T_{STG}$	-65 to +150	°C
Peak Package Reflow Temperature During Reflow <sup>(4),(5)</sup>	$T_{PPRT}$	Note 5	°C
Maximum Junction Temperature	$T_{J(MAX)}$	+150	°C
Power Dissipation ( $T_A = 85\text{ °C}$ ) <sup>(6)</sup>	$P_D$	2.9	W

## Notes

- Continuous output current capability so long as  $T_J$  is  $\leq T_{J(MAX)}$ .
- ESD testing is performed in accordance with the Human Body Model (HBM) ( $C_{ZAP} = 100\text{ pF}$ ,  $R_{ZAP} = 1500\ \Omega$ ), the Machine Model (MM) ( $C_{ZAP} = 200\text{ pF}$ ,  $R_{ZAP} = 0\ \Omega$ ), and the Charge Device Model (CDM), Robotic ( $C_{ZAP} = 4.0\text{ pF}$ ).
- The limiting factor is junction temperature, taking into account power dissipation, thermal resistance, and heatsinking.
- Pin soldering temperature limit is for 10 seconds maximum duration. Not designed for immersion soldering. Exceeding these limits may cause malfunction or permanent damage to the device.
- Freescale's Package Reflow capability meets Pb-free requirements for JEDEC standard J-STD-020C. For Peak Package Reflow Temperature and Moisture Sensitivity Levels (MSL), Go to [www.freescale.com](http://www.freescale.com), search by part number [e.g. remove prefixes/suffixes and enter the core ID to view all orderable parts. (i.e. MC33xxxD enter 33xxx)], and review parametrics.
- Maximum power dissipation at indicated ambient temperature.

**Table 2. Maximum Ratings (continued)**

All voltages are with respect to ground unless otherwise noted. Exceeding these ratings may cause a malfunction or permanent damage to the device.

Ratings	Symbol	Value	Unit
<b>THERMAL RESISTANCE</b> <sup>(7)</sup>			
Thermal Resistance, Junction to Ambient, Single-layer Board (1s) <sup>(8)</sup>	$R_{\theta JA}$	139	°C/W
Thermal Resistance, Junction to Ambient, Four-layer Board (2s2p) <sup>(9)</sup>	$R_{\theta JMA}$	43	°C/W
Thermal Resistance, Junction to Board <sup>(10)</sup>	$R_{\theta JB}$	22	°C/W

Notes

7. The PVIN, SW, and GND pins comprise the main heat conduction paths.
8. Per SEMI G38-87 and JEDEC JESD51-2 with the single-layer board (JESD51-3) horizontal.
9. Per JEDEC JESD51-6 with the board (JESD51-7) horizontal. There are no thermal vias connecting the package to the two planes in the board.
10. Thermal resistance between the device and the printed circuit board per JEDEC JESD51-8. Board temperature is measured on the top surface of the board near the package.

## STATIC ELECTRICAL CHARACTERISTICS

**Table 3. Static Electrical Characteristics**

Characteristics noted under conditions  $3.0\text{ V} \leq V_{IN} \leq 6.0\text{ V}$ ,  $-40^\circ\text{C} \leq T_A \leq 85^\circ\text{C}$ ,  $\text{GND} = 0\text{ V}$ , unless otherwise noted. Typical values noted reflect the approximate parameter means at  $T_A = 25^\circ\text{C}$  under nominal conditions, unless otherwise noted.

Characteristic	Symbol	Min	Typ	Max	Unit
<b>IC INPUT SUPPLY VOLTAGE (VIN)</b>					
Input Supply Voltage Operating Range	$V_{IN}$	3.0	-	6.0	V
Input DC Supply Current <sup>(11)</sup> Normal Mode: $\overline{\text{SD}} = 1$ & $\overline{\text{STBY}} = 1$ , Unloaded Outputs	$I_{IN}$	-	-	25	mA
Input DC Supply Current <sup>(11)</sup> Standby Mode, $\overline{\text{SD}} = 1$ & $\overline{\text{STBY}} = 0$	$I_{INQ}$	-	-	15	mA
Input DC Supply Current <sup>(11)</sup> Shutdown Mode, $\overline{\text{SD}} = 0$ & $\overline{\text{STBY}} = X$	$I_{INOFF}$	-	-	100	$\mu\text{A}$
<b>INTERNAL SUPPLY VOLTAGE OUTPUT (VDDI)</b>					
Internal Supply Voltage Range	$V_{DDI}$	2.35	2.5	2.65	V
<b>BUCK CONVERTER (PVIN, SW, GND, BOOT, INV, COMP)</b>					
High Side MOSFET Drain Voltage Range	$P_{VIN}$	2.5	-	6.0	V
Output Voltage Adjustment Range <sup>(12)</sup>	$V_{OUT}$	0.7	-	1.35	V
Output Voltage Accuracy <sup>(12),(13),(14)</sup>	-	-1.0	-	1.0	%
Line Regulation <sup>(12)</sup> Normal Operation, $V_{IN} = 3.0$ to $6.0\text{ V}$ , $I_{OUT} = \pm 3.0\text{ A}$	$REG_{LN}$	-1.0	-	1.0	%
Load Regulation <sup>(12)</sup> Normal Operation, $I_{OUT} = -3.0$ to $3.0\text{ A}$	$REG_{LD}$	-1.0	-	1.0	%
Error Amplifier Common Mode Voltage Range <sup>(12),(15)</sup>	$V_{REF}$	0.0	-	1.35	V
Output Under-voltage Threshold	$V_{UVR}$	-8.0	-	-1.5	%
Output Over-voltage Threshold	$V_{OVR}$	1.5	-	8.0	%
Continuous Output Current	$I_{OUT}$	-3.0	-	3.0	A
Over-current Limit, Sinking and Sourcing	$I_{LIM}$	-	4.0	-	A
Short-circuit Current Limit (Sourcing and Sinking)	$I_{SHORT}$	-	6.5	-	A
High Side N-CH Power MOSFET (M3) $R_{DS(ON)}$ <sup>(12)</sup> $I_{OUT} = 1.0\text{ A}$ , $V_{BOOT} - V_{SW} = 3.3\text{ V}$	$R_{DS(ON)HS}$	10	-	50	$\text{m}\Omega$
Low Side N-CH Power MOSFET (M4) $R_{DS(ON)}$ <sup>(12)</sup> $I_{OUT} = 1.0\text{ A}$ , $V_{IN} = 3.3\text{ V}$	$R_{DS(ON)LS}$	10	-	50	$\text{m}\Omega$

## Notes

- See section "MODES OF OPERATION", page 14 has a detailed description of the different operating modes of the 34712
- Design information only, this parameter is not production tested.
- $\pm 1\%$  is assured at room temperature.
- Overall output accuracy is directly affected by the accuracy of the external feedback network, 1% feedback resistors are recommended.
- The 1% output voltage regulation is only guaranteed for a common mode voltage range greater than or equal to 0.7 V at room temperature.

**Table 3. Static Electrical Characteristics**

Characteristics noted under conditions  $3.0\text{ V} \leq V_{IN} \leq 6.0\text{ V}$ ,  $-40^\circ\text{C} \leq T_A \leq 85^\circ\text{C}$ ,  $\text{GND} = 0\text{ V}$ , unless otherwise noted. Typical values noted reflect the approximate parameter means at  $T_A = 25^\circ\text{C}$  under nominal conditions, unless otherwise noted.

Characteristic	Symbol	Min	Typ	Max	Unit
M2 $R_{DS(ON)}$ ( $V_{IN} = 3.3\text{ V}$ , M2 is on)	$R_{DS(ON)M2}$	1.5	-	4.0	$\Omega$
SW Leakage Current (Standby and Shutdown modes)	$I_{SW}$	-10	-	10	$\mu\text{A}$
PVIN Pin Leakage Current (Standby and Shutdown Modes)	$I_{PVIN}$	-10	-	10	$\mu\text{A}$
INV Pin Leakage Current	$I_{INV}$	-1.0	-	1.0	$\mu\text{A}$
Error Amplifier DC Gain <sup>(16)</sup>	$A_{EA}$	-	150	-	dB
Error Amplifier Unit Gain Bandwidth <sup>(16)</sup>	$UGBW_{EA}$	-	3.0	-	MHz
Error Amplifier Slew Rate <sup>(16)</sup>	$SR_{EA}$	-	7.0	-	$\text{V}/\mu\text{s}$
Error Amplifier Input Offset <sup>(16)</sup>	$OFFSET_{EA}$	-3.0	0.0	3.0	mV
Thermal Shutdown Threshold <sup>(16)</sup>	$T_{SDFET}$	-	170	-	$^\circ\text{C}$
Thermal Shutdown Hysteresis <sup>(16)</sup>	$T_{SDHYFET}$	-	25	-	$^\circ\text{C}$

**OSCILLATOR (FREQ)**

Oscillator Frequency Adjusting Reference Voltage Range	$V_{FREQ}$	0.0	-	$V_{DDI}$	V
--	------------	-----	---	-----------	---

**TRACKING (VREFIN, VREFOUT, VOUT)**

VREFIN External Reference Voltage Range <sup>(16)</sup>	$V_{REFIN}$	0.0	-	2.7	V
VREFOUT Buffered Reference Voltage Range	$V_{REFOUT}$	0.0	-	1.35	V
VREFOUT Buffered Reference Voltage Accuracy <sup>(17)</sup>	-	-1.0	-	1.0	%
VREFOUT Buffered Reference Voltage Current Capability	$I_{REFOUT}$	0.0	-	8.0	mA
VREFOUT Buffered Reference Voltage Over-current Limit	$I_{REFOUTLIM}$	-	11	-	mA
VREFOUT Total Discharge Resistance <sup>(16)</sup>	$R_{TDR(M6)}$	-	50	-	$\Omega$
VOUT Total Discharge Resistance <sup>(16)</sup>	$R_{TDR(M5)}$	-	50	-	$\Omega$
VOUT Pin Leakage Current (Standby Mode, $V_{OUT} = 3.6\text{ V}$ )	$I_{VOUTLKG}$	-1.0	-	1.0	$\mu\text{A}$

**CONTROL AND SUPERVISORY (STBY, SD, PG)**

$\overline{\text{STBY}}$ High Level Input Voltage	$V_{STBYHI}$	2.0	-	-	V
$\overline{\text{STBY}}$ Low Level Input Voltage	$V_{STBYLO}$	-	-	0.4	V
$\overline{\text{STBY}}$ Pin Internal Pull-up Resistor	$R_{STBYUP}$	1.0	-	2.0	$\text{M}\Omega$
$\overline{\text{SD}}$ High Level Input Voltage	$V_{SDHI}$	2.0	-	-	V
$\overline{\text{SD}}$ Low Level Input Voltage	$V_{SDLO}$	-	-	0.4	V
$\overline{\text{SD}}$ Pin Internal Pull-up Resistor	$R_{SDUP}$	1.0	-	2.0	$\text{M}\Omega$
$\overline{\text{PG}}$ Low Level Output Voltage ( $I_{PG} = 3.0\text{ mA}$ )	$V_{PGLO}$	-	-	0.4	V
$\overline{\text{PG}}$ Pin Leakage Current (M1 is off, Pulled up to VIN)	$I_{PGLKG}$	-1.0	-	1.0	$\mu\text{A}$

Notes

16. Design information only, this parameter is not production tested.
17. The 1 % accuracy is only guaranteed for  $V_{REFOUT}$  greater than or equal to 0.7 V at room temperature.



**DYNAMIC ELECTRICAL CHARACTERISTICS**

**Table 4. Dynamic Electrical Characteristics**

Characteristics noted under conditions  $3.0\text{ V} \leq V_{IN} \leq 6.0\text{ V}$ ,  $-40^\circ\text{C} \leq T_A \leq 85^\circ\text{C}$ ,  $\text{GND} = 0\text{ V}$ , unless otherwise noted. Typical values noted reflect the approximate parameter means at  $T_A = 25^\circ\text{C}$  under nominal conditions, unless otherwise noted.

Characteristic	Symbol	Min	Typ	Max	Unit
<b>BUCK CONVERTER (PVIN, SW, GND, BOOT)</b>					
Switching Node (SW) Rise Time <sup>(19)</sup> ( $P_{VIN} = 3.3\text{ V}$ , $I_{OUT} = \pm 3.0\text{ A}$ )	$t_{RISE}$	-	14	-	ns
Switching Node (SW) Fall Time <sup>(19)</sup> ( $P_{VIN} = 3.3\text{ V}$ , $I_{OUT} = \pm 3.0\text{ A}$ )	$t_{FALL}$	-	20	-	ns
Minimum OFF Time	$t_{OFFMIN}$	-	150	-	ns
Minimum ON Time	$t_{ONMIN}$	-	180	-	ns
Soft Start Duration (Normal Mode)	$t_{SS}$	1.3	-	2.6	ms
Over-current Limit Timer	$t_{LIM}$	-	10	-	ms
Over-current Limit Retry Timeout Period	$t_{TIMEOUT}$	80	-	120	ms
Output Under-voltage/Over-voltage Filter Delay Timer	$t_{FILTER}$	5.0	-	25	$\mu\text{s}$
<b>OSCILLATOR (FREQ)</b>					
Oscillator Default Switching Frequency <sup>(18)</sup> ( $\text{FREQ} = \text{GND}$ )	$F_{SW}$	-	1.0	-	MHz
Oscillator Switching Frequency Range	$F_{SW}$	200	-	1000	kHz
<b>CONTROL AND SUPERVISORY (STBY, SD, PG)</b>					
$\overline{\text{PG}}$ Reset Delay	$t_{PGRESET}$	8.0	-	12	ms
Thermal Shutdown Retry Time-out Period <sup>(19)</sup>	$t_{TIMEOUT}$	80	-	120	ms

Notes

- 18. Oscillator Frequency tolerance is  $\pm 10\%$ .
- 19. Design information only, this parameter is not production tested.

## FUNCTIONAL DESCRIPTION

### INTRODUCTION

In modern microprocessor/memory applications, address commands and control lines require system level termination to a voltage ( $V_{TT}$ ) equal to  $1/2$  the memory supply voltage ( $V_{DDQ}$ ). Having the termination voltage at midpoint, the power supply insures symmetry for switching times. Also, a reference voltage ( $V_{REF}$ ) that is free of any noise or voltage variations is needed for the DDR SDRAM input receiver,  $V_{REF}$  is also equal to  $1/2 V_{DDQ}$ . Varying the  $V_{REF}$  voltage will effect the setup and hold time of the memory. To comply with DDR requirements and to obtain best performance,  $V_{TT}$  and  $V_{REF}$  need to be tightly regulated to track  $1/2 V_{DDQ}$  across voltage, temperature, and noise margins.  $V_{TT}$  should track any variations in the DC  $V_{REF}$  value ( $V_{TT} = V_{REF} \pm 40mV$ ), (See [Figure 4](#)) for a DDR system level diagram.

The 34712 supplies the  $V_{TT}$  and a buffered  $V_{REF}$  output. To ensure compliance with DDR specifications, the  $V_{DDQ}$  line is applied to the VREFIN pin and divided by 2 internally through a precision resistor divider. This internal voltage is then used as the reference voltage for the  $V_{TT}$  output. The same internal voltage is also buffered to give the  $V_{REF}$  voltage at the VREFOUT pin for the application to use without the need for an external resistor divider. The 34712 provides the tight voltage regulation and power sequencing/tracking required along with handling the DDR peak transient current requirements. Buffering the  $V_{REF}$  output helps its immunity against noise and load changes.

The 34712 utilizes a voltage mode synchronous buck switching converter topology with integrated low  $R_{DS(ON)}$  (50 m $\Omega$ ) N-channel power MOSFETs to provide a  $V_{TT}$  voltage with an accuracy of less than  $\pm 2.0\%$ . It has a programmable switching frequency that allows for flexibility and optimization over the operating conditions and can operate at up to 1.0 MHz to significantly reduce the external components size and cost. The 34712 can sink and source up to 3.0 A of

continuous current. It provides protection against output over-current, over-voltage, under-voltage, and over-temperature conditions. It also protects the system from short circuit events. It incorporates a power-good output signal to alert the host when a fault occurs.

For boards that support the Suspend-To-RAM (S3) and the Suspend-To-Disk (S5) states, the 34712 offers the STBY and the SD pins respectively. Pulling any of these pins low, puts the IC in the corresponding state.

By integrating the control/supervisory circuitry along with the Power MOSFET switches for the buck converter into a space-efficient package, the 34712 offers a complete, small-size, cost-effective, and simple solution to satisfy the needs of DDR memory applications.

Besides DDR memory termination, the 34712 can be used to supply termination for other active buses and graphics card memory. It can be used in Netcom/Telecom applications like servers. It can also be used in desktop motherboards, game consoles, set top boxes, and high end high definition TVs.

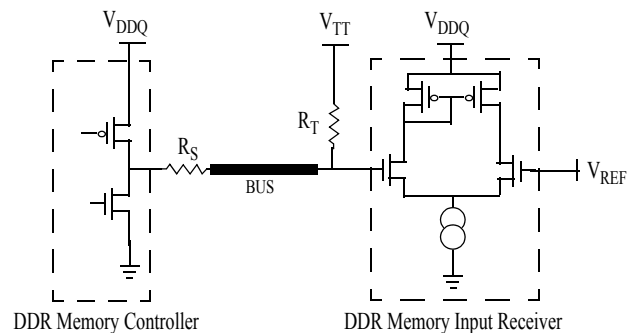

Figure 4. DDR System Level Diagram

### FUNCTIONAL PIN DESCRIPTION

#### REFERENCE VOLTAGE INPUT (VREFIN)

The 34712 will track  $1/2$  the voltage applied at this pin.

#### REFERENCE VOLTAGE OUTPUT (VREFOUT)

This is a buffered reference voltage output that is equal to  $1/2 V_{REFIN}$ . It has a 10 mA current drive capability. This output is used as the  $V_{REF}$  voltage rail and should be filtered against any noise. Connect a 0.1  $\mu F$ , 6.0 V low ESR ceramic filter capacitor between this pin and the GND pin and between this pin and  $V_{DDQ}$  rail.  $V_{REFOUT}$  is also used as the reference voltage for the buck converter error amplifier.

#### FREQUENCY ADJUSTMENT INPUT (FREQ)

The buck converter switching frequency can be adjusted by connecting this pin to an external resistor divider between VDDI and GND pins. The default switching frequency (FREQ pin connected to ground, GND) is set at 1.0 MHz.

#### SIGNAL GROUND (GND)

Analog ground of the IC. Internal analog signals are referenced to this pin voltage.

**INTERNAL SUPPLY VOLTAGE OUTPUT (VDDI)**

This is the output of the internal bias voltage regulator. Connect a 1.0  $\mu\text{F}$ , 6.0 V low ESR ceramic filter capacitor between this pin and the GND pin. Filtering any spikes on this output is essential to the internal circuitry stable operation.

**OUTPUT VOLTAGE DISCHARGE PATH (VOUT)**

Output voltage of the Buck Converter is connected to this pin. It only serves as the output discharge path once the  $\overline{\text{SD}}$  signal is asserted.

**ERROR AMPLIFIER INVERTING INPUT (INV)**

Buck converter error amplifier inverting input. Connect the VTT voltage directly to this pin.

**COMPENSATION INPUT (COMP)**

Buck converter external compensation network connects to this pin. Use a type III compensation network.

**INPUT SUPPLY VOLTAGE (VIN)**

IC power supply input voltage. Input filtering is required for the device to operate properly.

**POWER GROUND (PGND)**

Buck converter and discharge MOSFETs power ground. It is the source of the buck converter low side power MOSFET.

**SWITCHING NODE (SW)**

Buck converter switching node. This pin is connected to the output inductor.

**POWER INPUT VOLTAGE (PVIN)**

Buck converter power input voltage. This is the drain of the buck converter high side power MOSFET.

**BOOTSTRAP INPUT (BOOT)**

Bootstrap capacitor input pin. Connect a capacitor (as discussed on page 19) between this pin and the SW pin to enhance the gate of the high side Power MOSFET during switching.

**SHUTDOWN INPUT ( $\overline{\text{SD}}$ )**

If this pin is tied to the GND pin, the device will be in Shutdown mode. If left unconnected or tied to the VIN pin, the device will be in Normal mode. The pin has an internal pull-up of 1.5 M $\Omega$ . This input accepts the S5 (Suspend-To-Disk) control signal.

**STANDBY INPUT ( $\overline{\text{STBY}}$ )**

If this pin is tied to the GND pin, the device will be in Standby mode. If left unconnected or tied to the VIN pin, the device will be in Normal mode. The pin has an internal pull-up of 1.5 M $\Omega$ . This input accepts the S3 (Suspend-To-RAM) control signal.

**POWER GOOD OUTPUT SIGNAL ( $\overline{\text{PG}}$ )**

This is an active low open drain output that is used to report the status of the device to a host. This output activates after a successful power up sequence and stays active as long as the device is in normal operation and is not experiencing any faults. This output activates after a 10 ms delay and must be pulled up by an external resistor to a supply voltage (e.g.,  $V_{\text{IN}}$ ).

## FUNCTIONAL INTERNAL BLOCK DESCRIPTION

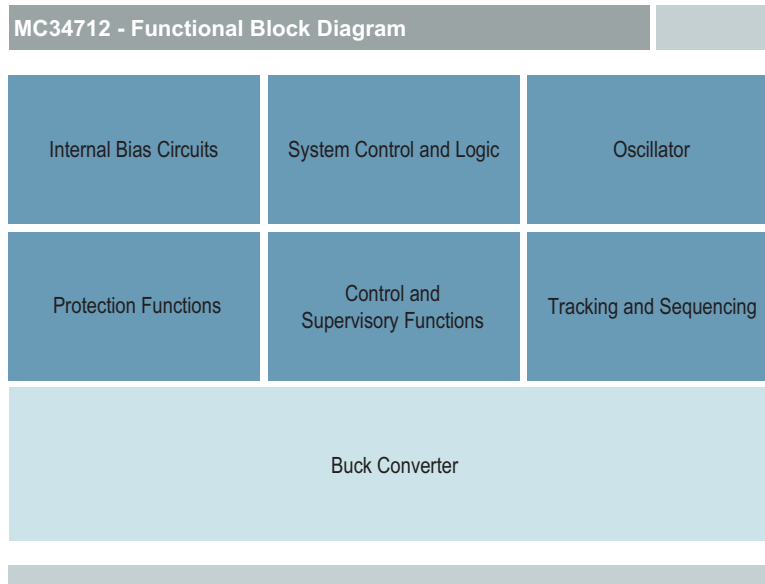

Figure 5. 34712 Internal Block Diagram

### INTERNAL BIAS CIRCUITS

This block contains all circuits that provide the necessary supply voltages and bias currents for the internal circuitry. It consists of:

- Internal voltage supply regulator: This regulator supplies the  $V_{DDI}$  voltage that is used to drive the digital/analog internal circuits. It is equipped with a Power-On-Reset (POR) circuit that watches for the right regulation levels. External filtering is needed on the VDDI pin. This block will turn off during the shutdown mode.
- Internal bandgap reference voltage: This supplies the reference voltage to some of the internal circuitry.
- Bias circuit: This block generates the bias currents necessary to run all of the blocks in the IC.

### SYSTEM CONTROL AND LOGIC

This block is the brain of the IC where the device processes data and reacts to it. Based on the status of the  $\overline{STBY}$  and  $\overline{SD}$  pins, the system control reacts accordingly and orders the device into the right status. It also takes inputs from all of the monitoring/protection circuits and initiates power up or power down commands. It communicates with the buck converter to manage the switching operation and protects it against any faults.

### OSCILLATOR

This block generates the clock cycles necessary to run the IC digital blocks. It also generates the buck converter switching frequency. The switching frequency has a default value of 1.0 MHz and can be programmed by connecting a

resistor divider to the FREQ pin, between VDDI and GND pins (See [Figure 1](#)).

### PROTECTION FUNCTIONS

This block contains the following circuits:

- Over-current limit and short-circuit detection: This block monitors the output of the buck converter for over current conditions and short circuit events and alerts the system control for further command.
- Thermal limit detection: This block monitors the temperature of the device for overheating events. If the temperature rises above the thermal shutdown threshold, this block will alert the system control for further commands.
- Output over-voltage and under-voltage monitoring: This block monitors the buck converter output voltage to ensure it is within regulation boundaries. If not, this block alerts the system control for further commands.

### CONTROL AND SUPERVISORY FUNCTIONS

This block is used to interface with an outside host. It contains the following circuits:

- Standby control input: An outside host can put the 34712 device into standby mode (S3 or Suspend-To-RAM mode) by sending a logic "0" to the  $\overline{STBY}$  pin.
- Shutdown control input: An outside host can put the 34712 device into shutdown mode (S5 or Suspend-To-Disk mode) by sending a logic "0" to the  $\overline{SD}$  pin.
- Power good output signal  $\overline{PG}$ : The 34712 can communicate to an external host that a fault has

occurred by releasing the drive on the  $\overline{\text{PG}}$  pin high, allowing the signal/pin to be pulled high by the external pull-up resistor.

### TRACKING AND SEQUENCING

This block allows the output of the 34712 to track 1/2 the voltage applied at the VREFIN pin. This allows the  $V_{\text{REF}}$  and  $V_{\text{TT}}$  voltages to track 1/2  $V_{\text{DDQ}}$  and assures that none of them will be higher than  $V_{\text{DDQ}}$  at any point during normal operating conditions. For power down during a shutdown (S5) mode, the 34712 uses internal discharge MOSFETs (M5 and M6 on [Figure 2](#)) to discharge  $V_{\text{TT}}$  and  $V_{\text{REF}}$  respectively. These discharge MOSFETs are only active during shutdown mode. Using this block along with controlling the  $\overline{\text{SD}}$  and  $\overline{\text{STBY}}$  pins can offer the user power sequencing capabilities by controlling when to turn the 34712 outputs on or off.

### BUCK CONVERTER

This block provides the main function of the 34712: DC to DC conversion from an un-regulated input voltage to a

regulated output voltage used by the loads for reliable operation. The buck converter is a high performance, fixed frequency (externally adjustable), synchronous buck PWM voltage-mode control. It drives integrated 50 m $\Omega$  N-channel power MOSFETs saving board space and enhancing efficiency. The switching regulator output voltage is adjustable with an accuracy of less than  $\pm 2.0\%$  to meet DDR requirements. Its output has the ability to track 1/2 the voltage applied at the VREFIN pin. The regulator's voltage control loop is compensated using a type III compensation network, with external components to allow for optimizing the loop compensation, for a wide range of operating conditions. A typical Bootstrap circuit with an internal PMOS switch is used to provide the voltage necessary to properly enhance the high-side MOSFET gate.

The 34712 is designed to address DDR memory power supplies. The integrated converter has the ability to both sink and source up to 3.0 A of continuous current, making it suitable for bus termination power supplies.

## FUNCTIONAL DEVICE OPERATION

### OPERATIONAL MODES

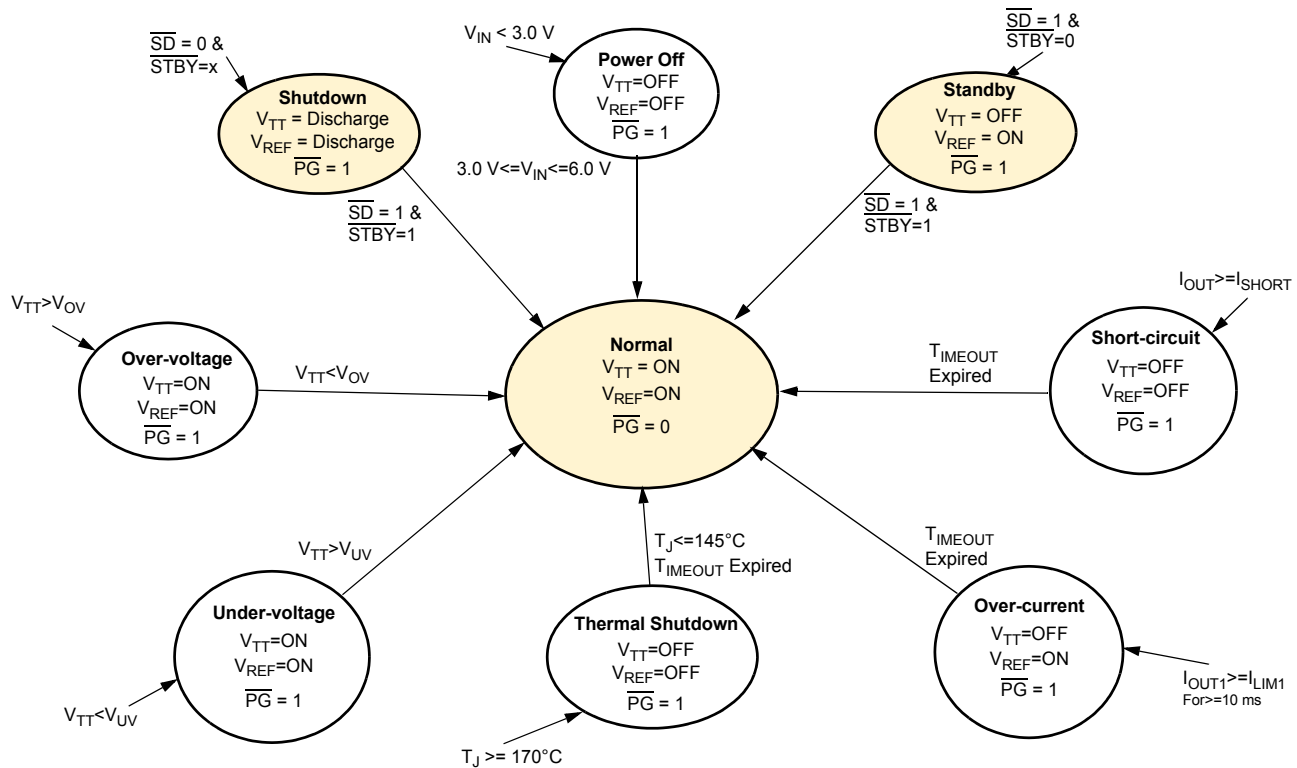

Figure 6. Operation Modes Diagram

### MODES OF OPERATION

The 34712 has three primary modes of operation:

#### Normal Mode

In normal mode, all functions and outputs are fully operational. To be in this mode, the  $V_{IN}$  needs to be within its operating range, both Shutdown and Standby inputs are high, and no faults are present. This mode consumes the most amount of power.

#### Standby Mode

This mode is predominantly used in Desktop memory solutions where the DDR supply is desired to be ACPI compliant (Advanced Configuration and Power Interface). When this mode is activated by pulling the  $\overline{STBY}$  pin low,  $V_{TT}$  is put in High Z state,  $I_{OUT} = 0$  A, and  $V_{REF}$  stays active. This is the S3 state Suspend-To-Ram or Self Refresh mode and it is the lowest DRAM power state. In this mode, the DRAM will preserve the data. While in this mode, the 34712 consumes less power than in the normal mode, because the buck converter and most of the internal blocks are disabled.

#### Shutdown Mode

In this mode, activated by pulling the  $\overline{SD}$  pin low, the chip is in a shutdown state and the outputs are all disabled and discharged. This is the S4/S5 power state or Suspend-To-Disk state, where the DRAM will lose all of its data content (no power supplied to the DRAM). The reason to discharge the  $V_{TT}$  and  $V_{REF}$  lines is to ensure upon exiting the Shutdown Mode that  $V_{TT}$  and  $V_{REF}$  are lower than  $V_{DDQ}$ , otherwise  $V_{TT}$  can remain floating high, and be higher than  $V_{DDQ}$  upon powering up. In this mode, the 34712 consumes the least amount of power since almost all of the internal blocks are disabled.

#### START-UP SEQUENCE

When power is first applied, the 34712 checks the status of the  $\overline{SD}$  and  $\overline{STBY}$  pins. If the device is in a shutdown mode, no block will power up and the output will not attempt to ramp. If the device is in a standby mode, only the  $V_{DD1}$  internal supply voltage and the bias currents are established and no further activities will occur. Once the  $\overline{SD}$  and  $\overline{STBY}$  pins are released to enable the device, the internal  $V_{DD1}$  POR signal is also released. The rest of the internal blocks will be enabled

and the buck converter switching frequency value is determined by reading the  $FREQ$  pin. A soft start cycle is then initiated to ramp up the output of the buck converter ( $V_{TT}$ ). The buck converter error amplifier uses the voltage on the  $VREFOUT$  pin ( $V_{REF}$ ) as its reference voltage.  $V_{REF}$  is equal to  $1/2 V_{DDQ}$ , where  $V_{DDQ}$  is applied to the  $VREFIN$  pin. This way, the 34712 assures that  $V_{REF}$  and  $V_{TT}$  voltages track  $1/2 V_{DDQ}$  to meet DDR requirements.

Soft start is used to prevent the output voltage from overshooting during startup. At initial startup, the output capacitor is at zero volts;  $V_{OUT} = 0$  V. Therefore, the voltage across the inductor will be  $PV_{IN}$  during the capacitor charge phase which will create a very sharp  $di/dt$  ramp. Allowing the inductor current to rise too high can result in a large difference between the charging current and the actual load current that can result in an undesired voltage spike once the capacitor is fully charged. The soft start is active each time

the IC goes out of standby or shutdown mode, power is recycled, or after a fault retry.

To fully take advantage of soft starting, it is recommended not to enable the 34712 output before introducing  $V_{DDQ}$  on the  $VREFIN$  pin. If this happens after a soft start cycle expires and the  $VREFIN$  voltage has a high  $dv/dt$ , the output will naturally track it immediately and ramp up with a fast  $dv/dt$  itself and that will defeat the purpose of soft starting. For reliable operation, it is best to have the  $V_{DDQ}$  voltage available before enabling the output of the 34712.

After a successful start-up cycle where the device is enabled, no faults have occurred, and the output voltage has reached its regulation point, the 34712 pulls the power good output signal low after a 10ms reset delay, to indicate to the host that the device is in normal operation.

## PROTECTION AND DIAGNOSTIC FEATURES

The 34712 monitors the application for several fault conditions to protect the load from overstress. The reaction of the IC to these faults ranges from turning off the outputs to just alerting the host that something is wrong. In the following paragraphs, each fault condition is explained:

### Output Over-voltage

An over-voltage condition occurs once the output voltage goes higher than the rising over-voltage threshold ( $V_{OVR}$ ). In this case, the power good output signal is pulled high, alerting the host that a fault is present, but the  $V_{TT}$  and  $V_{REF}$  outputs will stay active. To avoid erroneous over-voltage conditions, a 20  $\mu$ s filter is implemented. The buck converter will use its feedback loop to attempt to correct the fault. Once the output voltage falls below the falling over-voltage threshold ( $V_{OVF}$ ), the fault is cleared and the power good output signal is pulled low, the device is back in normal operation.

### Output Under-voltage

An under-voltage condition occurs once the output voltage falls below the falling under-voltage threshold ( $V_{UVF}$ ). In this case, the power good output signal is pulled high, alerting the host that a fault is present, but the  $V_{TT}$  and  $V_{REF}$  outputs will stay active. To avoid erroneous under-voltage conditions, a 20  $\mu$ s filter is implemented. The buck converter will use its feedback loop to attempt to correct the fault. Once the output voltage rises above the rising under-voltage threshold ( $V_{UVR}$ ), the fault is cleared and the power good output signal is pulled low, the device is back in normal operation.

### Output Over-current

This block detects over-current in the Power MOSFETs of the buck converter. It is comprised of a sense MOSFET and a comparator. The sense MOSFET acts as a current detecting device by sampling a ratio of the load current. That sample is compared via the comparator with an internal reference to determine if the output is in over-current or not. If the peak current in the output inductor reaches the over

current limit ( $I_{LIM}$ ), the converter will start a cycle-by-cycle operation to limit the current, and a 10 ms over-current limit timer ( $t_{LIM}$ ) starts. The converter will stay in this mode of operation until one of the following occurs:

- The current is reduced back to the normal level before  $t_{LIM}$  expires, and in this case normal operation is regained.
- $t_{LIM}$  expires without regaining normal operation, at which point the device turns off the output and the power good output signal is pulled high. At the end of a timeout period of 100 ms ( $t_{TIMEOUT}$ ), the device will attempt another soft start cycle.
- The device reaches the thermal shutdown limit ( $T_{SDFET}$ ) and turns off the output. The power good output signal is pulled high.

### Short-circuit Current Limit

This block uses the same current detection mechanism as the over-current limit detection block. If the load current reaches the  $I_{SHORT}$  value, the device reacts by shutting down the output immediately. This is necessary to prevent damage in case of a permanent short circuit. Then, at the end of a timeout period of 100 ms ( $t_{TIMEOUT}$ ), the device will attempt another soft start cycle.

### Thermal Shutdown

Thermal limit detection block monitors the temperature of the device and protects against excessive heating. If the temperature reaches the thermal shutdown threshold ( $T_{SDFET}$ ), the converter output switches off and the power good output signal indicates a fault by pulling high. The device will stay in this state until the temperature has decreased by the hysteresis value and then After a timeout period ( $T_{TIMEOUT}$ ) of 100 ms, the device will retry automatically and the output will go through a soft start cycle. If successful normal operation is regained, the power good output signal is asserted low to indicate that.

## TYPICAL APPLICATIONS

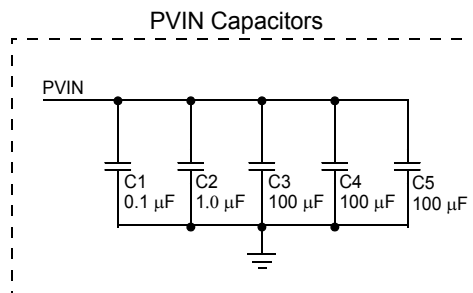
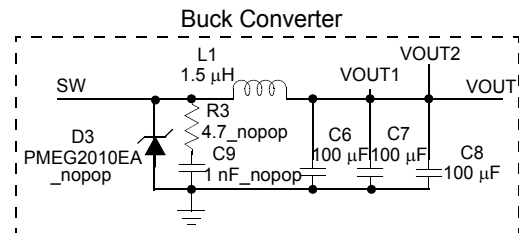
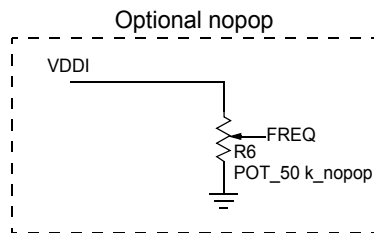
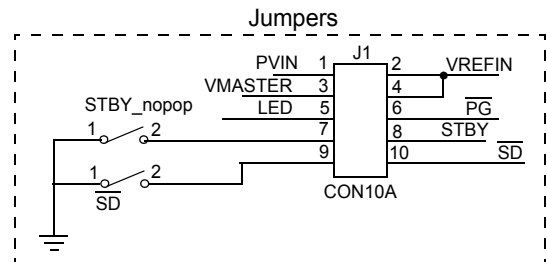
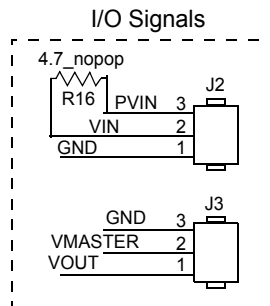
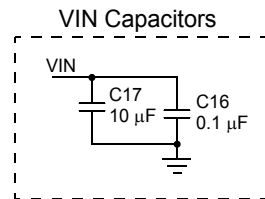
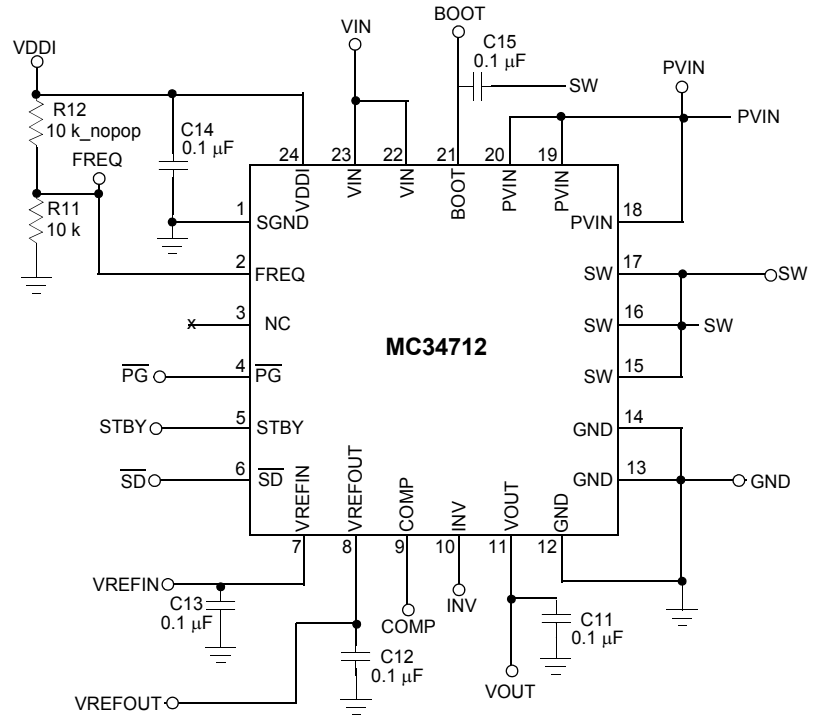
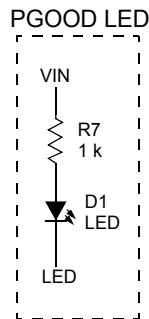
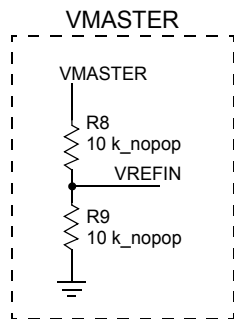
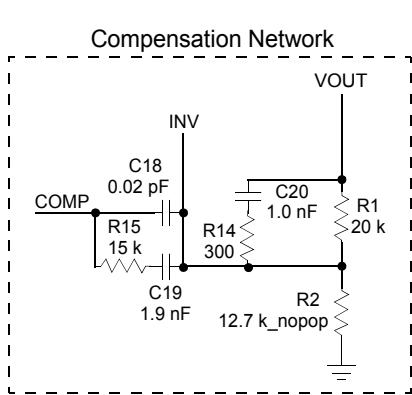



## COMPONENT SELECTION

### SWITCHING FREQUENCY SELECTION

The switching frequency defaults to a value of 1.0 MHz when the FREQ pin is grounded, and 200 kHz when the FREQ pin is connected to VDDI. Intermediate switching frequencies can be obtained by connecting an external resistor divider to the FREQ pin. The table below shows the resulting switching frequency versus FREQ pin voltage.

**Table 5. Switching Frequency Adjustment**

FREQUENCY	VOLTAGE APPLIED TO PIN FREQ
200	2.341 - 2.500
253	2.185 - 2.340
307	2.029 - 2.184
360	1.873 - 2.028
413	1.717 - 1.872
466	1.561 - 1.716
520	1.405 - 1.560
573	1.249 - 1.404
627	1.093 - 1.248
680	0.936 - 1.092
733	0.781 - 0.936
787	0.625 - 0.780
840	0.469 - 0.624
893	0.313 - 0.468
947	0.157 - 0.312
1000	0.000 - 0.156

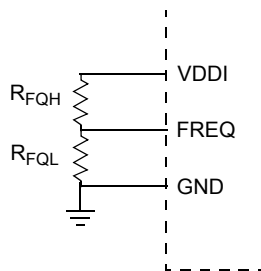

**Figure 7. Resistor Divider for Frequency Adjustment**

### SELECTION OF THE INDUCTOR

Inductor calculation is straight forward, being

$$L = D'_{MAX} * T * \frac{(V_o + I_o * (R_{DS(ON)ES} + R_{INDUCTOR}))}{\Delta I_o}$$

where,

$$D'_{MAX} = 1 - \frac{V_o}{V_{in\_max}}$$

Maximum OFF time percentage

$T$

Switching period.

$R_{DS(ON)ES}$

Drain – to – source resistance of FET

$R_{INDUCTOR}$

Winding resistance of Inductor

$$\Delta I_o = 0.4 * I_o$$

Output current ripple.

### OUTPUT FILTER CAPACITOR

For the output capacitor, the following considerations are more important than the actual capacitance value, the physical size, the ESR and the voltage rating:

**Transient Response percentage, TR\_%**

(Use a recommended value of 2 to 4% to assure a good transient response.)

**Maximum Transient Voltage, TR\_v\_dip =  $V_o * TR\_%$**

Maximum current step,

$$\Delta I_o\_step = \frac{(V_{in\_min} - V_o) * D\_max}{F_{sw} * L}$$

**Inductor Current rise time,**

$$dt\_I\_rise = \frac{T * I_o}{\Delta I_o\_step}$$

where,

$D\_max$  = Maximum ON time percentage.

$I_o$  = Rated output current.

$V_{in\_min}$  = Minimum input voltage at  $PV_{IN}$

As a result, it is possible to calculate

$$C_o = \frac{I_o * dt\_I\_rise}{TR\_V\_dip}$$

In order to find the maximum allowed ESR,

$$ESR_{max} = \frac{\Delta V_o * F_{sw} * L}{V_o(1 - D_{min})}$$

The effects of the ESR is often neglected by the designers and may present a hidden danger to the ultimate supply stability. Poor quality capacitors have widely disparate ESR value, which can make the closed loop response inconsistent.

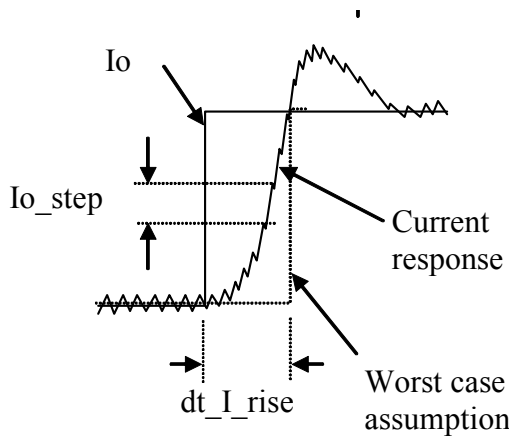

Figure 8. Transient Parameters

### TYPE III COMPENSATION NETWORK

Power supplies are desired to offer accurate and tight regulation output voltages. To accomplish this requires a high DC gain. But with high gain comes the possibility of instability. The purpose of adding compensation to the internal error amplifier is to counteract some of the gains and phases contained in the control-to-output transfer function that could jeopardized the stability of the power supply. The Type III compensation network used for 34712 comprises two poles (one integrator and one high frequency pole to cancel the zero generated from the ESR of the output capacitor) and two zeros to cancel the two poles generated from the LC filter as shown in [Figure 9](#).

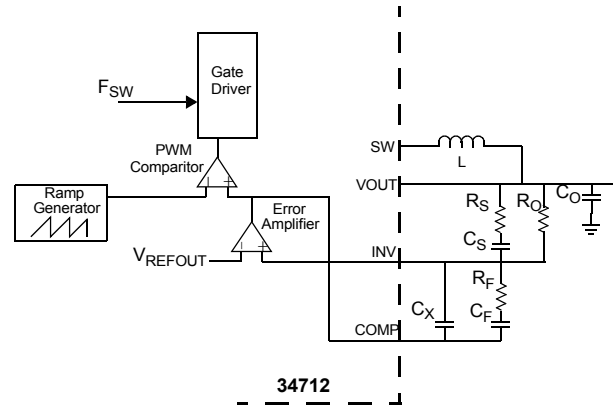

Figure 9. Type III Compensation Network

Consider the crossover frequency,  $F_{CROSS}$ , of the open loop gain at one-tenth of the switching frequency,  $F_{SW}$ .

Then,

$$F_{CROSS} = \frac{10}{2\pi \cdot R_O C_F} \Rightarrow$$

$$C_F = \frac{10}{2\pi \cdot R_O F_{CROSS}}$$

where  $R_O$  is a user selected resistor. Knowing the LC frequency, it can be obtained the values of  $R_F$  and  $C_S$ :

$$F_{LC} = \frac{1}{2\pi \sqrt{LC_o}} = F_{Z1} = F_{Z2}$$

$$F_{Z1} = \frac{1}{2\pi * R_F C_F}$$

$$F_{Z2} = \frac{1}{2\pi * R_O C_S}$$

This gives as a result,

$$R_F = \frac{1}{2\pi * C_F F_{Z1}} \quad \&$$

$$C_S = \frac{1}{2\pi * R_O F_{Z2}}$$

Calculate  $R_S$  by placing the Pole 1 at the ESR zero frequency:

$$F_{ESR} = \frac{1}{2\pi * C_o * ESR} = F_{P1}$$

$$F_{P1} = \frac{1}{2\pi * R_s C_s}$$

$$\Rightarrow R_s = \frac{1}{2\pi * F_{P1} C_s}$$

Equating the Pole 2 to 5 times the Crossover Frequency to achieve a faster response and a proper phase margin,

$$5 \cdot F_{CROSS} = F_{P2} = \frac{1}{2\pi \cdot R_F \frac{C_F C_X}{C_F + C_X}}$$

$$\Rightarrow C_X = \frac{C_F}{2\pi * R_F C_F F_{P2} - 1}$$

### BOOTSTRAP CAPACITOR

The bootstrap capacitor is needed to supply the gate voltage for the high side MOSFET. This N-Channel MOSFET needs a voltage difference between its gate and source to be able to turn on. The high side MOSFET source is the SW node, so it is not ground and it is floating and moving in voltage, so we cannot just apply a voltage directly to the gate of the high side that is referenced to ground, we need a voltage referenced to the SW node. That is why the bootstrap capacitor is needed for. This capacitor charges during the high side off time, since the low side will be on during that time, so the SW node and the bottom of the bootstrap capacitor will be connected to ground and the top of the capacitor will be connected to a voltage source, so the capacitor will charge up to that voltage source (say 5.0 V). Now when the low side MOSFET switches off and the high side MOSFET switches on, the SW nodes rises up to Vin, and the voltage on the boot pin will be Vcap + Vin. So the gate of the high side will have Vcap across it and it will be able to

stay enhanced. A 0.1 μF capacitor is a good value for this bootstrap element.

### LAYOUT GUIDELINES

The layout of any switching regulator requires careful consideration. First, there are high di/dt signals present, and the traces carrying these signals need to be kept as short and as wide as possible to minimize the trace inductance, and therefore reduce the voltage spikes they can create. To do this, an understanding of the major current carrying loops is important. See [Figure 10](#). These loops, and their associated components, should be placed in such a way as to minimize the loop size to prevent coupling to other parts of the circuit. Also, the current carrying power traces and their associated return traces should run adjacent to one another, to minimize the amount of noise coupling. If sensitive traces must cross the current carrying traces, they should be made perpendicular to one another to reduce field interaction.

Second, small signal components which connect to sensitive nodes need consideration. The critical small signal components are the ones associated with the feedback circuit. The high impedance input of the error amp is especially sensitive to noise, and the feedback and compensation components should be placed as far from the switch node, and as close to the input of the error amplifier as possible. Other critical small signal components include the bypass capacitors for VIN, VREFIN, and VDDI. Locate the bypass capacitors as close to the pin as possible.

The use of a multi-layer printed circuit board is recommended. Dedicate one layer, usually the layer under the top layer, as a ground plane. Make all critical component ground connections with vias to this layer. Make sure that the power ground, PGND, is connected directly to the ground plane and not routed through the thermal pad or analog ground. Dedicate another layer as a power plane and split this plane into local areas for common voltage nets.

The IC input supply (VIN) should be connected with a dedicated trace to the input supply. This will help prevent noise from the Buck Regulator's power input (PVIN) from injecting switching noise into the IC's analog circuitry.

In order to effectively transfer heat from the top layer to the ground plane and other layers of the printed circuit board, thermal vias need to be used in the thermal pad design. It is recommended that 5 to 9 vias be spaced evenly and have a finished diameter of 0.3 mm.

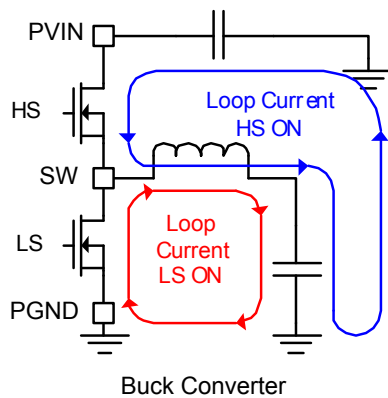

**Figure 10. Current Loops**

# PACKAGING

## PACKAGING DIMENSIONS

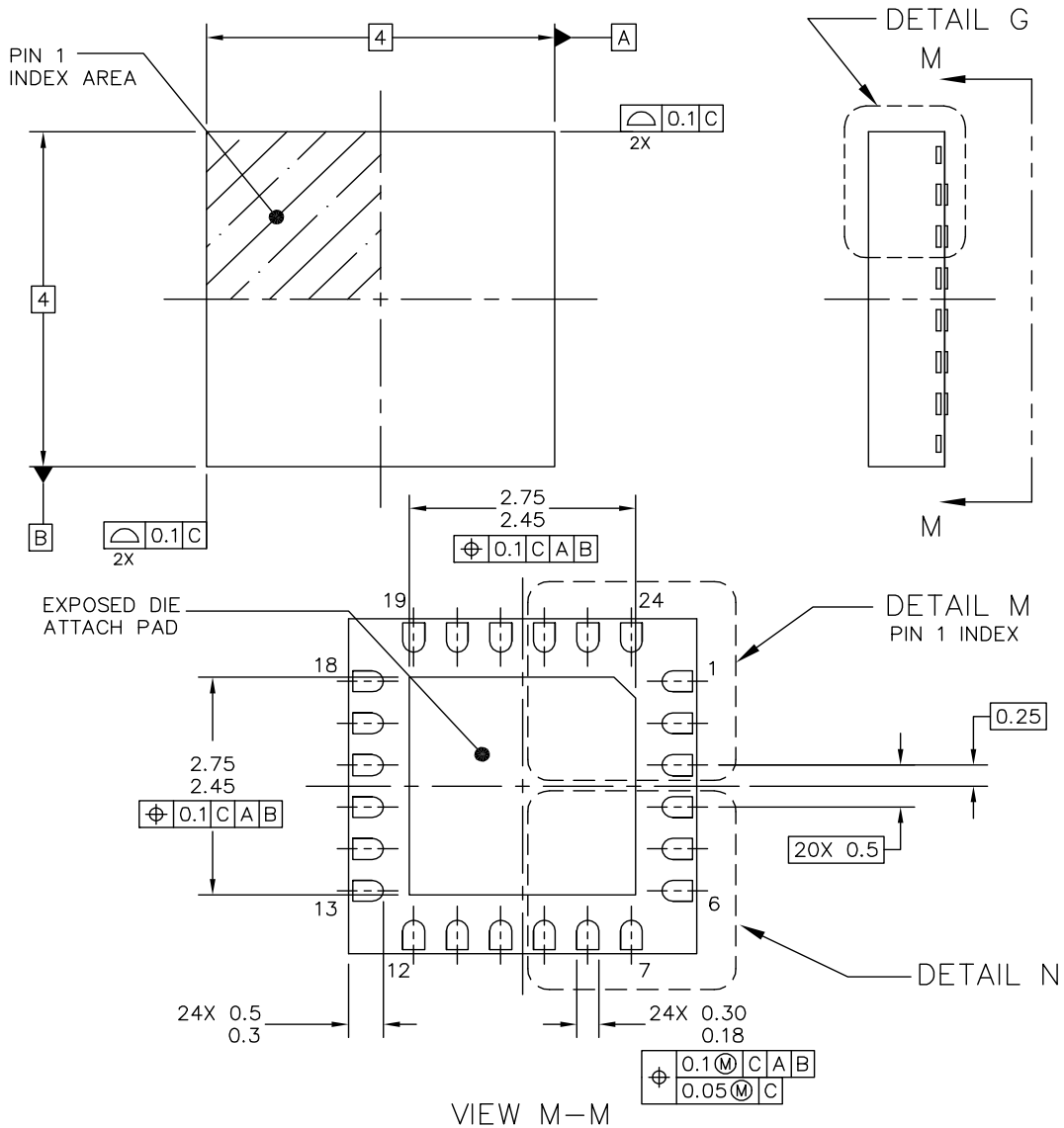

© FREESCALE SEMICONDUCTOR, INC. ALL RIGHTS RESERVED.	<b>MECHANICAL OUTLINE</b>	PRINT VERSION NOT TO SCALE	
TITLE: THERMALLY ENHANCED QUAD FLAT NON-LEADED PACKAGE (QFN) 24 TERMINAL, 0.5 PITCH (4 X 4 X 1)	DOCUMENT NO: 98ARL10577D	REV: B	
	CASE NUMBER: 1508-02	28 DEC 2005	
	STANDARD: NON-JEDEC		

**EP SUFFIX**  
24 -PIN  
98ARL10577D  
ISSUE B

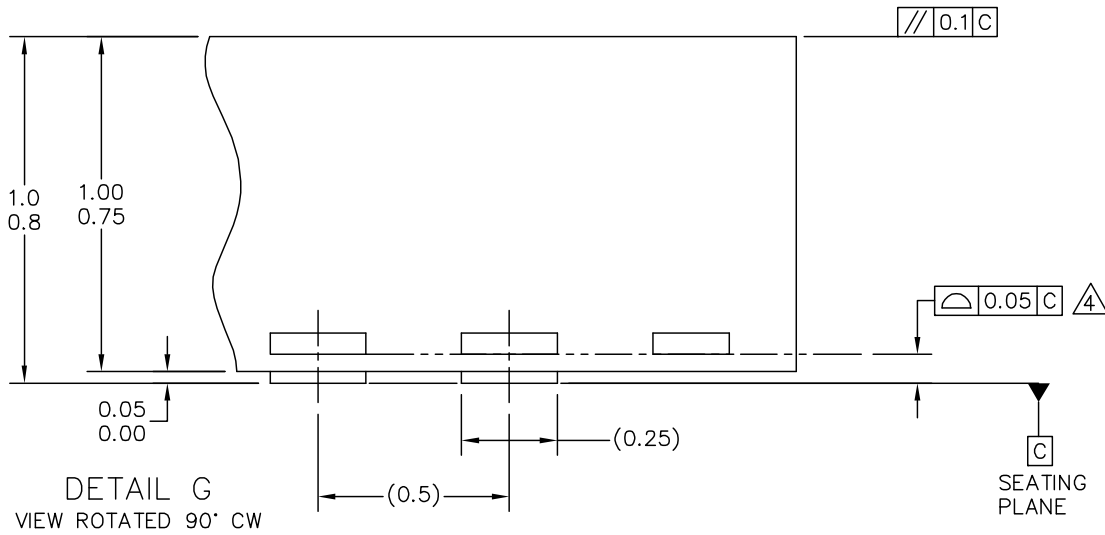
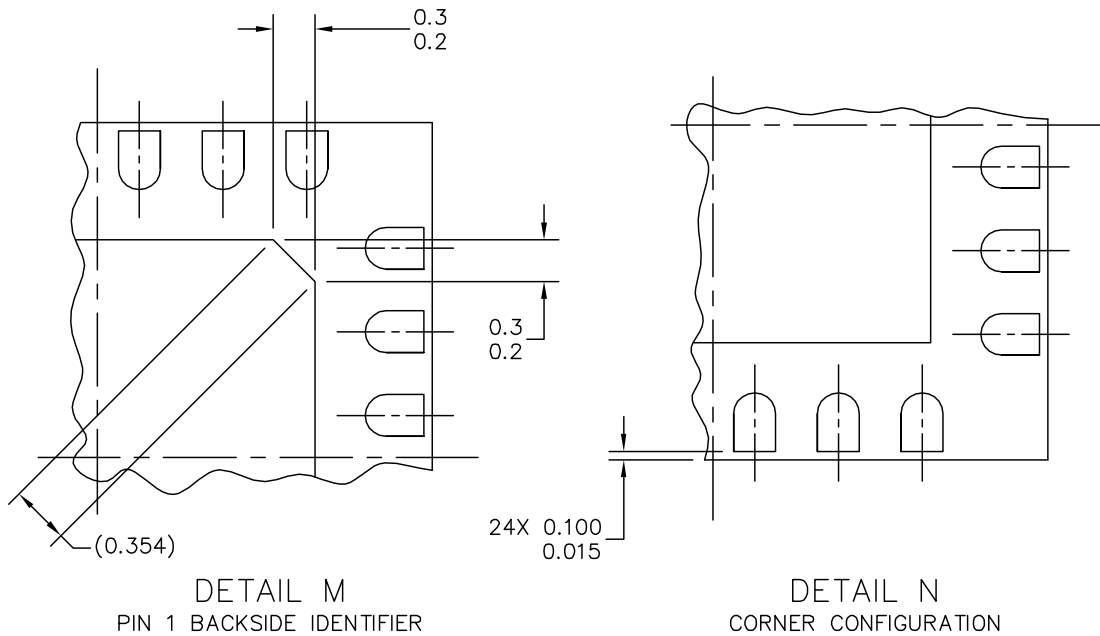

© FREESCALE SEMICONDUCTOR, INC. ALL RIGHTS RESERVED.	<b>MECHANICAL OUTLINE</b>	PRINT VERSION NOT TO SCALE	
TITLE: THERMALLY ENHANCED QUAD FLAT NON-LEADED PACKAGE (QFN) 24 TERMINAL, 0.5 PITCH (4 X 4 X 1)	DOCUMENT NO: 98ARL10577D	REV: B	
	CASE NUMBER: 1508-02	28 DEC 2005	
	STANDARD: NON-JEDEC		

**EP SUFFIX**  
24 -PIN  
98ARL10577D  
ISSUE B

## REVISION HISTORY

REVISION	DATE	DESCRIPTION OF CHANGES
1.0	2/2006	<ul style="list-style-type: none"> <li>Pre-release version</li> <li>Implemented Revision History page</li> </ul>
2.0	11/2006	<ul style="list-style-type: none"> <li>Initial release</li> <li>Converted format from Market Assessment to Product Preview</li> <li>Major updates to the data, form, and style</li> </ul>
3.0	2/2007	<ul style="list-style-type: none"> <li>Replaced all electrolytic capacitors with ceramic ones in <a href="#">Figure 1</a></li> <li>Deleted Deadtime in <a href="#">Dynamic Electrical Characteristics</a></li> <li>Moved <a href="#">Figures 8</a> ahead of <a href="#">TYPE III COMPENSATION NETWORK</a></li> </ul>
4.0	5/2007	<ul style="list-style-type: none"> <li>Changed Features fom 2% to 1%</li> <li>Changed <a href="#">34712 Simplified Application Diagram</a></li> <li>Removed Machine Model in <a href="#">Maximum Ratings</a></li> <li>Added minimum limits to <a href="#">Input DC Supply Current</a><sup>(11)</sup> Normal mode, <a href="#">Input DC Supply Current</a><sup>(11)</sup> Standby mode, and <a href="#">Input DC Supply Current</a><sup>(11)</sup> Shutdown mode</li> <li>Added <a href="#">High Side MOSFET Drain Voltage Range</a></li> <li>Changed <a href="#">Output Voltage Accuracy</a><sup>(12), (13), (14)</sup></li> <li>Changed <a href="#">Short-circuit Current Limit</a></li> <li>Changed <a href="#">High Side N-CH Power MOSFET (M3) RDS(ON)</a><sup>(12)</sup> and <a href="#">Low Side N-CH Power MOSFET (M4) RDS(ON)</a><sup>(12)</sup></li> <li>Changed <a href="#">M2 RDS(ON)</a></li> <li>Changed <a href="#">PVIN Pin Leakage Current</a></li> <li>Changed <a href="#">VREFOUT Buffered Reference Voltage Accuracy</a><sup>(17)</sup>, <a href="#">VREFOUT Buffered Reference Voltage Current Capability</a>, and <a href="#">VREFOUT Buffered Reference Voltage Over-current Limit</a></li> <li>Changed <a href="#">STBY Pin Internal Pull-up Resistor</a> and <a href="#">SD Pin Internal Pull-up Resistor</a></li> <li>Changed <a href="#">Soft Start Duration</a>, <a href="#">Over-current Limit Retry Timeout Period</a>, and <a href="#">Output Under-voltage/Over-voltage Filter Delay Timer</a></li> <li>Changed <a href="#">Oscillator Default Switching Frequency</a><sup>(18)</sup></li> <li>Changed <a href="#">PG Reset Delay</a> and <a href="#">Thermal Shutdown Retry Time-out Period</a><sup>(19)</sup></li> <li>Changed drawings in <a href="#">Typical Applications</a></li> <li>Changed drawing in <a href="#">Type III Compensation Network</a></li> <li>Removed PC34712EP/R2 from the ordering information and added MC34712EP/R2</li> <li>Changed the data sheet status to Advance Information</li> </ul>
5.0	12/2008	<ul style="list-style-type: none"> <li>Made changes to <a href="#">Switching Node (SW) Pin</a>, <a href="#">BOOT Pin (Referenced to SW Pin)</a>, <a href="#">Output Under-voltage Threshold</a>, <a href="#">Output Over-voltage Threshold</a>, <a href="#">High Side N-CH Power MOSFET (M3) RDS(ON)</a><sup>(12)</sup>, <a href="#">Low Side N-CH Power MOSFET (M4) RDS(ON)</a><sup>(12)</sup>, <a href="#">Device Charge Model (CDM)</a></li> <li>Added <a href="#">Machine Model (MM)</a>, <a href="#">SW Leakage Current (Standby and Shutdown modes)</a>, <a href="#">Error Amplifier DC Gain</a><sup>(16)</sup>, <a href="#">Error Amplifier Unit Gain Bandwidth</a><sup>(16)</sup>, <a href="#">Error Amplifier Slew Rate</a><sup>(16)</sup>, <a href="#">Error Amplifier Input Offset</a><sup>(16)</sup></li> <li>Added pin 25 to <a href="#">Figure 3</a> and the <a href="#">34712 Pin Definitions</a></li> <li>Added the section <a href="#">Layout Guidelines</a></li> </ul>
6.0	4/2012	<ul style="list-style-type: none"> <li>Changed typical for <a href="#">Minimum ON Time</a> on page 9</li> </ul>

---

**How to Reach Us:**

**Home Page:**

freescale.com

**Web Support:**

freescale.com/support

Information in this document is provided solely to enable system and software implementers to use Freescale products. There are no express or implied copyright licenses granted hereunder to design or fabricate any integrated circuits on the information in this document.

Freescale reserves the right to make changes without further notice to any products herein. Freescale makes no warranty, representation, or guarantee regarding the suitability of its products for any particular purpose, nor does Freescale assume any liability arising out of the application or use of any product or circuit, and specifically disclaims any and all liability, including without limitation consequential or incidental damages. "Typical" parameters that may be provided in Freescale data sheets and/or specifications can and do vary in different applications, and actual performance may vary over time. All operating parameters, including "typicals," must be validated for each customer application by customer's technical experts. Freescale does not convey any license under its patent rights nor the rights of others. Freescale sells products pursuant to standard terms and conditions of sale, which can be found at the following address: <http://www.reg.net/v2/webservices/Freescale/Docs/TermsandConditions.htm>

Freescale, the Freescale logo, Altivec, C-5, CodeTest, CodeWarrior, ColdFire, C-Ware, Energy Efficient Solutions logo, mobileGT, PowerQUICC, QorIQ, Qorivva, StarCore, and Symphony are trademarks of Freescale Semiconductor, Inc., Reg. U.S. Pat. & Tm. Off. Airfast, BeeKit, BeeStack, ColdFire+, CoreNet, Flexis, MagniV, MXC, Platform in a Package, Processor expert, QorIQ Qonverge, QUICC Engine, Ready Play, SMARTMOS, TurboLink, Vybrid, and Xtrinsic are trademarks of Freescale Semiconductor, Inc. All other product or service names are the property of their respective owners.

© 2012 Freescale Semiconductor, Inc.

Document Number: MC34712

Rev. 6.0

4/2012

