

To our customers,

Old Company Name in Catalogs and Other Documents

On April 1st, 2010, NEC Electronics Corporation merged with Renesas Technology Corporation, and Renesas Electronics Corporation took over all the business of both companies. Therefore, although the old company name remains in this document, it is a valid Renesas Electronics document. We appreciate your understanding.

Renesas Electronics website: <http://www.renesas.com>

April 1st, 2010
Renesas Electronics Corporation

Issued by: Renesas Electronics Corporation (<http://www.renesas.com>)

Send any inquiries to <http://www.renesas.com/inquiry>.

Notice

1. All information included in this document is current as of the date this document is issued. Such information, however, is subject to change without any prior notice. Before purchasing or using any Renesas Electronics products listed herein, please confirm the latest product information with a Renesas Electronics sales office. Also, please pay regular and careful attention to additional and different information to be disclosed by Renesas Electronics such as that disclosed through our website.
2. Renesas Electronics does not assume any liability for infringement of patents, copyrights, or other intellectual property rights of third parties by or arising from the use of Renesas Electronics products or technical information described in this document. No license, express, implied or otherwise, is granted hereby under any patents, copyrights or other intellectual property rights of Renesas Electronics or others.
3. You should not alter, modify, copy, or otherwise misappropriate any Renesas Electronics product, whether in whole or in part.
4. Descriptions of circuits, software and other related information in this document are provided only to illustrate the operation of semiconductor products and application examples. You are fully responsible for the incorporation of these circuits, software, and information in the design of your equipment. Renesas Electronics assumes no responsibility for any losses incurred by you or third parties arising from the use of these circuits, software, or information.
5. When exporting the products or technology described in this document, you should comply with the applicable export control laws and regulations and follow the procedures required by such laws and regulations. You should not use Renesas Electronics products or the technology described in this document for any purpose relating to military applications or use by the military, including but not limited to the development of weapons of mass destruction. Renesas Electronics products and technology may not be used for or incorporated into any products or systems whose manufacture, use, or sale is prohibited under any applicable domestic or foreign laws or regulations.
6. Renesas Electronics has used reasonable care in preparing the information included in this document, but Renesas Electronics does not warrant that such information is error free. Renesas Electronics assumes no liability whatsoever for any damages incurred by you resulting from errors in or omissions from the information included herein.
7. Renesas Electronics products are classified according to the following three quality grades: “Standard”, “High Quality”, and “Specific”. The recommended applications for each Renesas Electronics product depends on the product’s quality grade, as indicated below. You must check the quality grade of each Renesas Electronics product before using it in a particular application. You may not use any Renesas Electronics product for any application categorized as “Specific” without the prior written consent of Renesas Electronics. Further, you may not use any Renesas Electronics product for any application for which it is not intended without the prior written consent of Renesas Electronics. Renesas Electronics shall not be in any way liable for any damages or losses incurred by you or third parties arising from the use of any Renesas Electronics product for an application categorized as “Specific” or for which the product is not intended where you have failed to obtain the prior written consent of Renesas Electronics. The quality grade of each Renesas Electronics product is “Standard” unless otherwise expressly specified in a Renesas Electronics data sheets or data books, etc.
 - “Standard”: Computers; office equipment; communications equipment; test and measurement equipment; audio and visual equipment; home electronic appliances; machine tools; personal electronic equipment; and industrial robots.
 - “High Quality”: Transportation equipment (automobiles, trains, ships, etc.); traffic control systems; anti-disaster systems; anti-crime systems; safety equipment; and medical equipment not specifically designed for life support.
 - “Specific”: Aircraft; aerospace equipment; submersible repeaters; nuclear reactor control systems; medical equipment or systems for life support (e.g. artificial life support devices or systems), surgical implantations, or healthcare intervention (e.g. excision, etc.), and any other applications or purposes that pose a direct threat to human life.
8. You should use the Renesas Electronics products described in this document within the range specified by Renesas Electronics, especially with respect to the maximum rating, operating supply voltage range, movement power voltage range, heat radiation characteristics, installation and other product characteristics. Renesas Electronics shall have no liability for malfunctions or damages arising out of the use of Renesas Electronics products beyond such specified ranges.
9. Although Renesas Electronics endeavors to improve the quality and reliability of its products, semiconductor products have specific characteristics such as the occurrence of failure at a certain rate and malfunctions under certain use conditions. Further, Renesas Electronics products are not subject to radiation resistance design. Please be sure to implement safety measures to guard them against the possibility of physical injury, and injury or damage caused by fire in the event of the failure of a Renesas Electronics product, such as safety design for hardware and software including but not limited to redundancy, fire control and malfunction prevention, appropriate treatment for aging degradation or any other appropriate measures. Because the evaluation of microcomputer software alone is very difficult, please evaluate the safety of the final products or system manufactured by you.
10. Please contact a Renesas Electronics sales office for details as to environmental matters such as the environmental compatibility of each Renesas Electronics product. Please use Renesas Electronics products in compliance with all applicable laws and regulations that regulate the inclusion or use of controlled substances, including without limitation, the EU RoHS Directive. Renesas Electronics assumes no liability for damages or losses occurring as a result of your noncompliance with applicable laws and regulations.
11. This document may not be reproduced or duplicated, in any form, in whole or in part, without prior written consent of Renesas Electronics.
12. Please contact a Renesas Electronics sales office if you have any questions regarding the information contained in this document or Renesas Electronics products, or if you have any other inquiries.

(Note 1) “Renesas Electronics” as used in this document means Renesas Electronics Corporation and also includes its majority-owned subsidiaries.

(Note 2) “Renesas Electronics product(s)” means any product developed or manufactured by or for Renesas Electronics.

M62437FP

Sound Controller With SRS Focus & SRS Surround

REJ03F0216-0201

Rev.2.01

Mar 31, 2008

Description

This is an IC for car audio.

F(●)cus system can realize more optimal speaker position.

Features

- Built-in F(●)cus [LF/HF elevation (position) and Bass Compensation can be changed by the external resistors.]
- Built-in SR
- SRS ON/OFF mode and FOCUS ON/OFF mode can be controlled by the DC voltage.

Recommended Operating Condition

Supply voltage range: $V_{CC} = 7$ to 9 V

Rated supply voltage: $V_{CC} = 8$ V

System Block Diagram

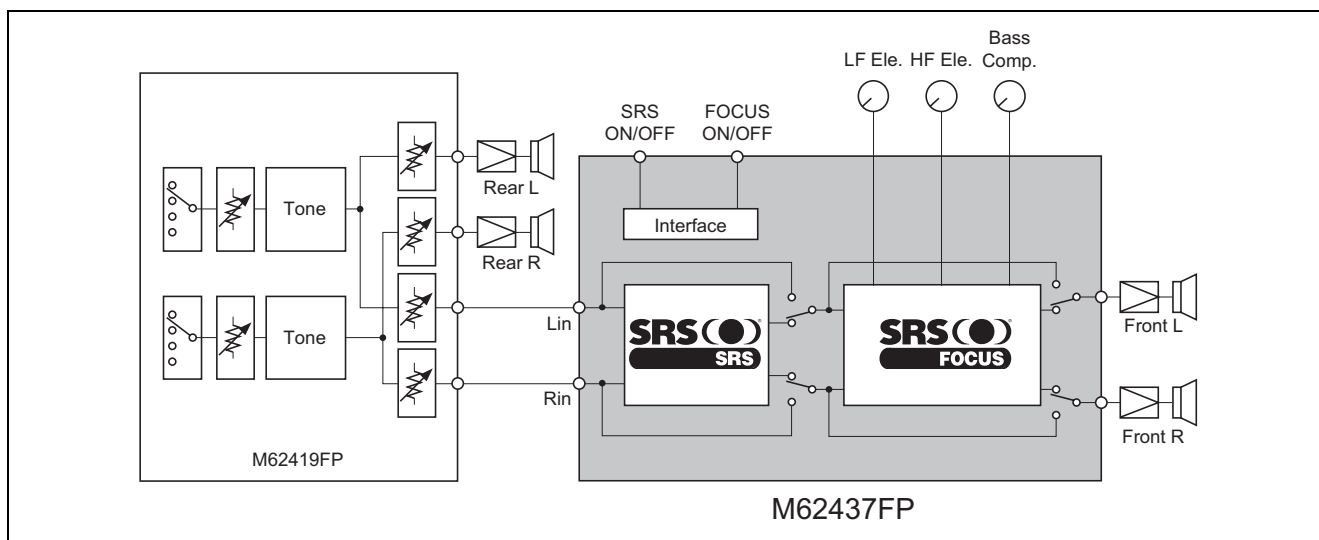

Block Diagram & Application Example

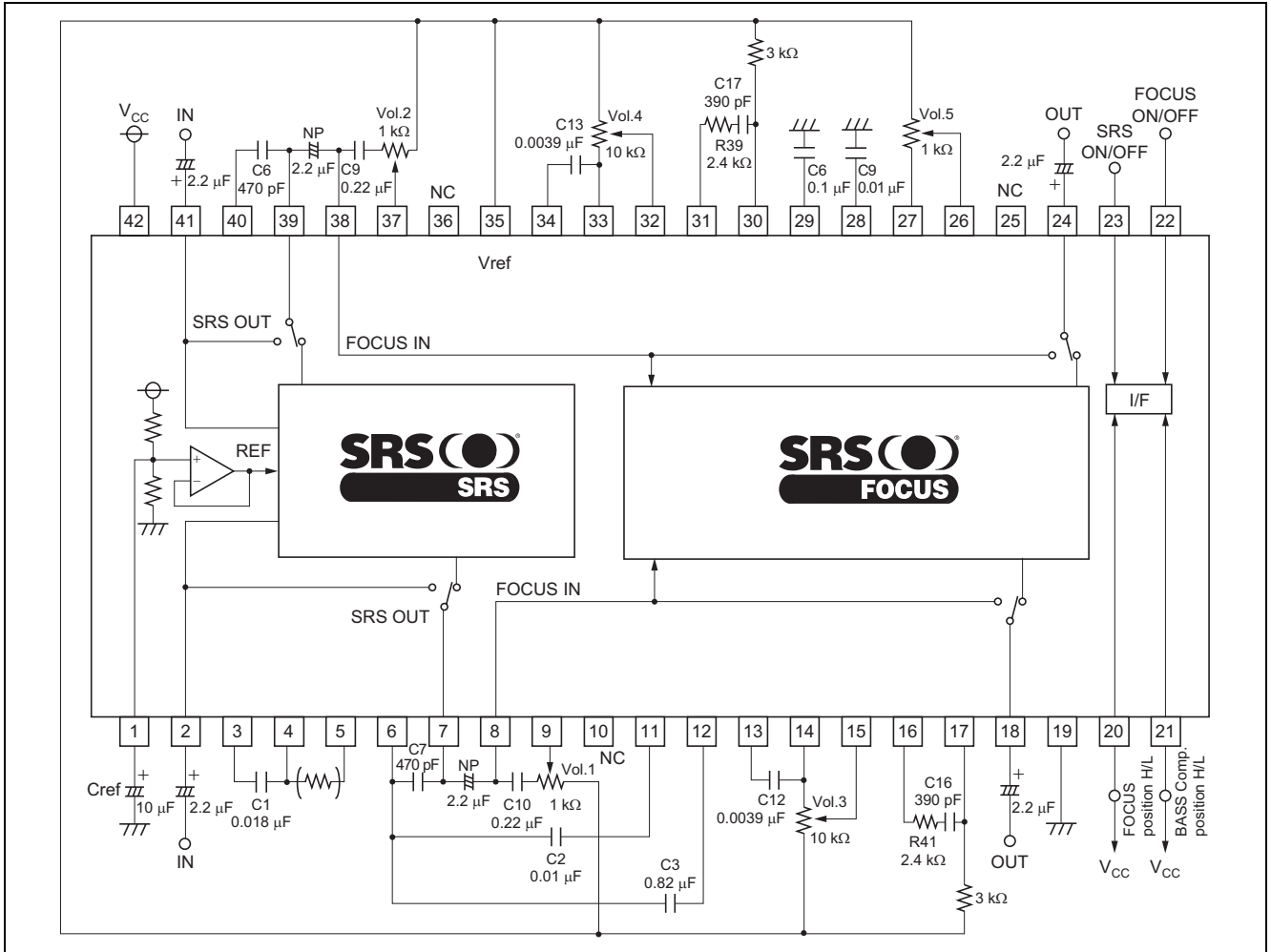

Absolute Maximum Ratings

(Ta = 25°C, unless otherwise noted)

Item	Symbol	Ratings	Unit	Condition
Supply Voltage	V _{CC} , V _{DD}	12	V	
Power Dissipation	P _d	990	mW	T _a ≤ 25°C
Thermal Derating	K _θ	9.9	mW/°C	T _a > 25°C
Operating Temperature	T _{opr}	-20 to +75	°C	
Storage Temperature	T _{stg}	-55 to +125	°C	

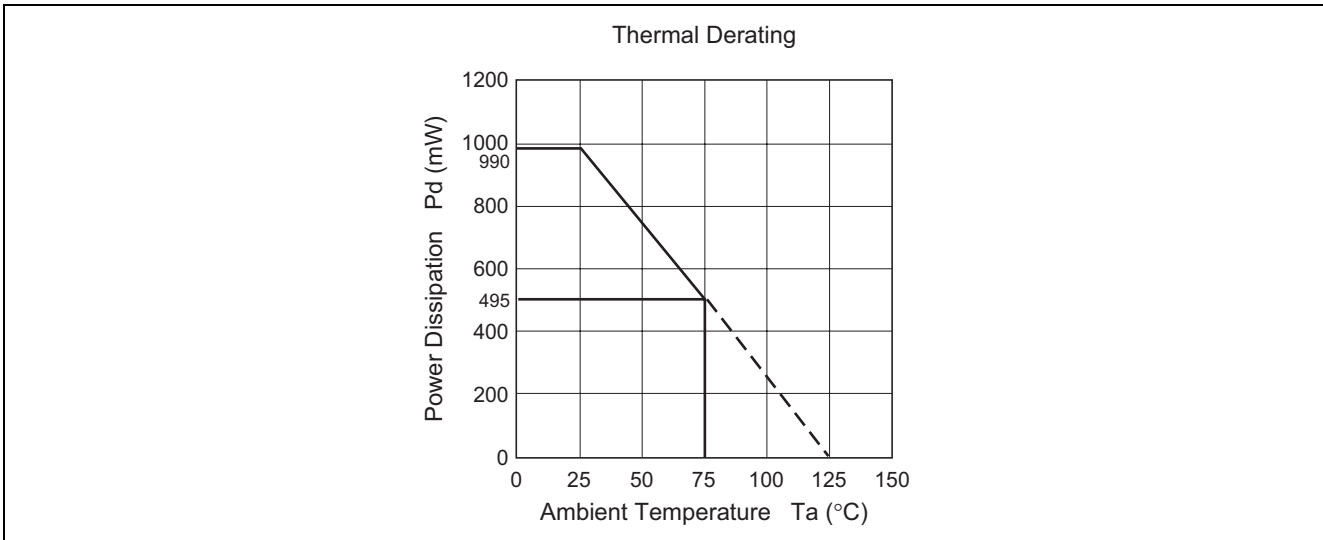

Electrical Characteristics

(1) Power supply characteristics

($T_a = 25^\circ\text{C}$, $V_{CC} = 8.0\text{V}$, $f = 1\text{kHz}$)

Item	Symbol	Limits			Unit	Conditions
		Min	Typ	Max		
Circuit current	I_{CC}	—	25	45	mA	42pin I_{CC} No Signal

(2) Input/Output characteristics

($T_a = 25^\circ\text{C}$, $V_{CC} = 8.0\text{V}$, $f = 1\text{kHz}$, VOL.1, 2 = $1\text{k}\Omega$ (VOL), VOL.3, 4 = $10\text{k}\Omega$ (VOL), VOL.5 = $1\text{k}\Omega$ (VOL))

Item	Symbol	Limits			Unit	Conditions
		Min	Typ	Max		
Maximum output voltage	VOMt	1.6	1.9	—	Vrms	Input; pin2, 41 Output; pin18, 24 $R_L = 10\text{k}\Omega$, THD = 1%
Maximum input voltage	VIM1	0.4	0.6	—	Vrms	Input; pin2, 41 Output; pin18, 24 SRS→ON, FOCUS→OFF THD = 1% f = 150Hz
	VIM2	0.2	0.3	—		Input; pin2, 41/Output; pin18, 24 SRS→ON f = 1kHz
	VIM3	0.06	0.11	—		FOCUS→ON (All VOL. = max) THD = 1% f = 20kHz
Pass gain	Gvt	-2.0	0	2.0	dB	$V_i = 100\text{mVrms}$ SRS, Focus→OFF Input; pin2, 41/Output; pin18, 24
	Gv1	7	10	13		$V_i = 100\text{mVrms}$ Input; pin2, 41/Output ; pin18, 24 SRS→ON, FOCUS→OFF f = 150Hz
	Gv2	15	18	21		$V_i = 100\text{mVrms}$ SRS→ON f = 1kHz
	Gv3	25	28	31		FOCUS→ON (All VOL. = max) (2pin, 41pin)-(18, 24Pin) f = 20kHz
Output noise voltage	Vno1	—	5.5	15	μVrms	$R_g = 0$ (2, 41pin) SRS→OFF, FOCUS→OFF DIN-AUDIO filter
	Vno2	—	18	50		$R_g = 0$ (2, 41pin) SRS→ON, FOCUS→OFF DIN-AUDIO filter
	Vno3	—	90	150		$R_g = 0$ (2, 41pin), SRS→ON, FOCUS→ON (All VOL. = max) DIN-AUDIO filter
Channel separation	CT	—	-90	-75	dB	Input side: $f = 1\text{kHz}$, $V_i = 0.5\text{Vrms}$ Monitor side: $R_g = 0$, IHF-A filter Focus: OFF, SRS: OFF $R_L = 10\text{k}\Omega$

(3) DC Control Characteristic of the Switch Block

Item	Symbol	Limits			Unit	Conditions
		Min	Typ	Max		
"H" level input voltage	V_{IH}	2.1	~	V_{CC}	V	Pin 22, 23
"L" level input voltage	V_{IL}	0	~	0.8	V	Pin 22, 23

Switch Condition and the Mode

(23) SRS 3D Stereo	SRS ON/OFF Switch
SRS ON	H
SRS OFF	L

(22) FOCUS	FOCUS ON/OFF Switch
FOCUS ON	H
FOCUS OFF	L

Note: Bypass mode can be set by both SRS ON/OFF switch and FOCUS ON/OFF switch are set to “L”.

Application Circuit Example

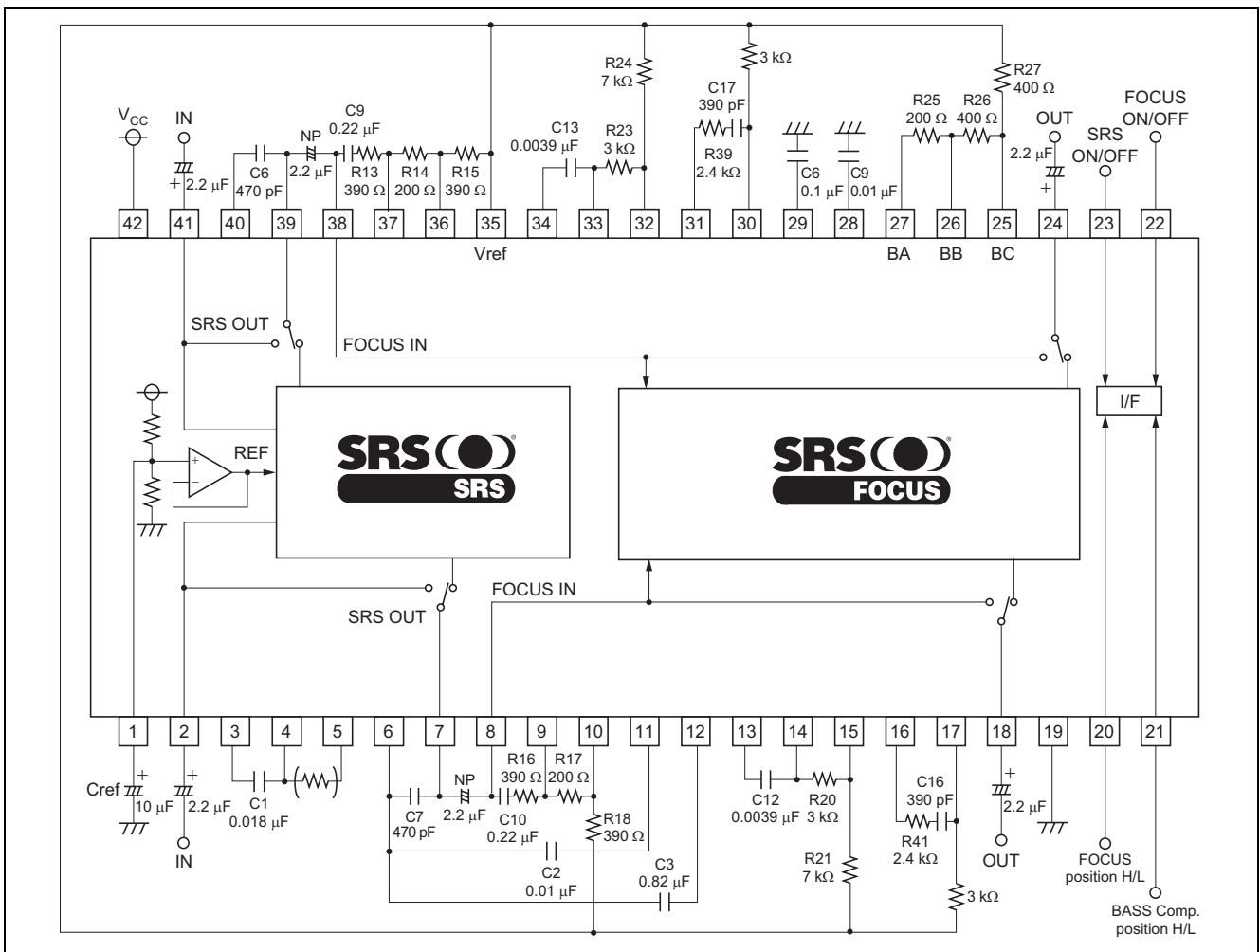

Regarding to the other Application Circuit

- R16 (R13), R17 (R14), R18 (R15)

The resistors of R16 (R13), R17 (R14), R18 (R15) can be set the FOCUS position (LF Elevation).

Note: This figure shows only the side channel.

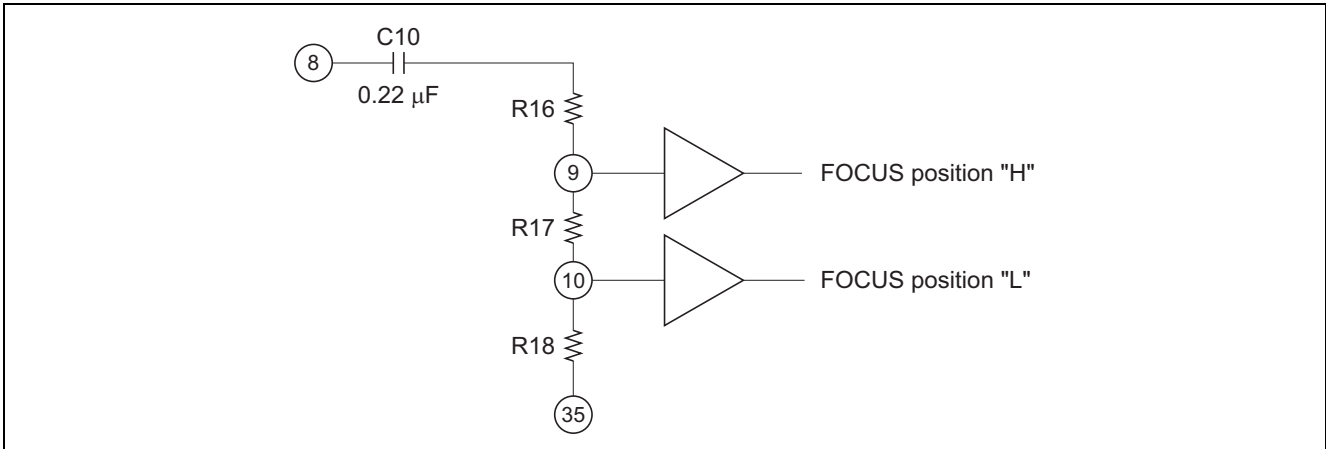

1. The setting of the FOCUS position “H”

$$\frac{R17 + R18}{R16 + R17 + R18}$$

2. The setting of the FOCUS position “L”

$$\frac{R18}{R16 + R17 + R18}$$

Note: please keep the following formula.

$$R16 + R17 + R18 \approx 1 \text{ k}\Omega$$

(Example)

In the case of R16 = 390 Ω, R17 = 200 Ω, R18 = 390 Ω

FOCUS position “H” ≈ 60%

FOCUS position “L” ≈ 40%

(Switch Setting)

	FOCUS ON/OFF Switch (22 Pin)	FOCUS Position H/L Switch (20 Pin)
FOCUS Position “H” (LF Elevation)	H	H
FOCUS Position “L” (LF Elevation)	H	L

- R20 (R23) , R21 (R24)

The resistors of R20 (R23), R21 (R24) can be set the HF Elevation.

Note: This figure shows only the side channel.

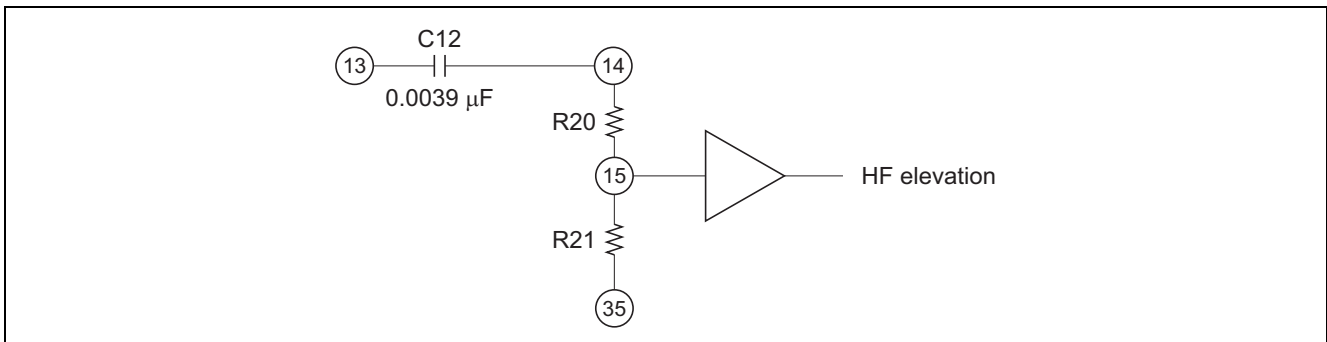

1. The setting of the HF Elevation.

$$\frac{R21}{R20 + R21}$$

Note: please keep the following formula.

$$R20 + R21 \approx 10 \text{ k}\Omega$$

(Example)

In the case of R20 = 3 kΩ, R21 = 7 kΩ

HF Elevation ≈ 70%

- R25, R26, R27

The resistors of R25, R26, R27 can be set the Bass Compensation.

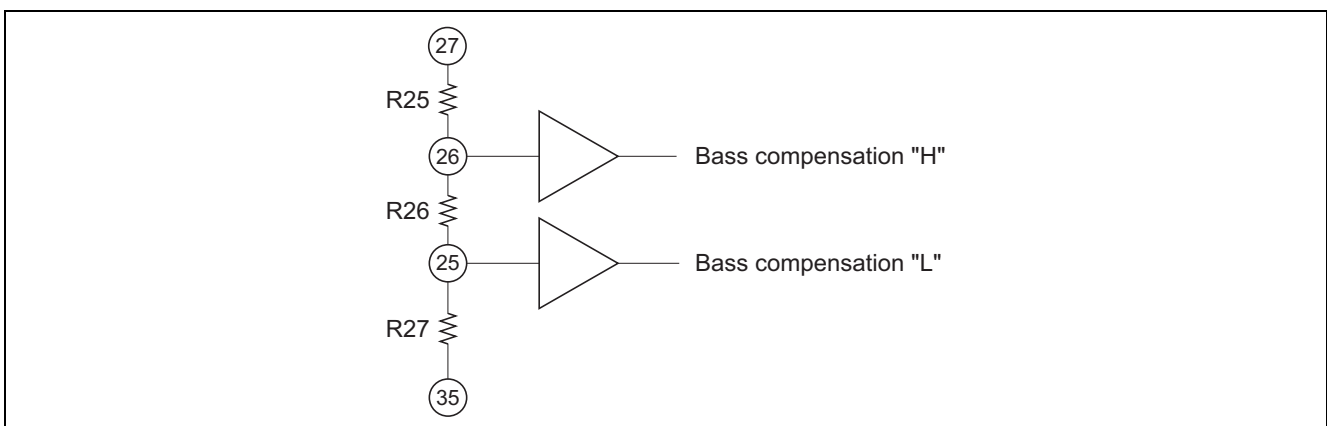

1. The setting of the Bass Compensation “H”

$$\frac{R26 + R27}{R25 + R26 + R27}$$

2. The setting of the Bass Compensation “L”

$$\frac{R27}{R25 + R26 + R27}$$

Note: please keep the following formula.

$$R25 + R26 + R27 \approx 1 \text{ k}\Omega$$

(Example)

In the case of R25 = 200 Ω, R26 = 390 Ω, R27 = 390 Ω

Bass Compensation “H” ≈ 80%

Bass Compensation “L” ≈ 40%

(Switch Setting)

	FOCUS ON/OFF Switch (22 Pin)	Bass Comp. H/L Switch (21 Pin)
Bass Compensation "H"	H	H
Bass Compensation "L"	H	L

Between Pin16 (31) and Pin17 (30)

Add 10 k of resistors between Pin16(31) and Pin17(30), can adjust the difference between the sound level of Focus ON and the sound level of Focus OFF.

Also add 10 k of resistors between Pin16(31) and Pin17(30), can decrease the Focus gain.

Then the maximum input voltage and the output noise voltage can be improved.

(Reference)

In the case of

(VOL.1, 2 = 1k Ω , VOL.3, 4 = 10k Ω , VOL.5 = 1k Ω , Add 10k Ω of resistors between Pin16(31) and Pin17(30))

Item	Symbol	Typ.	Unit	Conditions	
Maximum output voltage	VOMt	1.9	Vrms	Input; pin2, 41 Output; pin18, 24 RL = 10k Ω , THD = 1%	
Maximum input voltage	VIM1	0.6	Vrms	Input; pin2, 41/Output; pin18, 24 SRS→ON, FOCUS→OFF THD = 1%	f = 150Hz
	VIM2	0.55		Input; pin2, 41/Output; pin18, 24 SRS→ON	f = 1kHz
	VIM3	0.2		FOCUS→ON (All VOL. = max) THD = 1%	f = 20kHz
Pass gain	Gvt	0	dB	Vi = 100mVrms SRS, Focus→OFF Input; pin2, 41/Output ; pin18, 24	
	Gv1	10		Vi=100mVrms Input; pin2, 41/Output ; pin18, 24 SRS→ON, FOCUS→OFF	f = 150Hz
	Gv2	12		Vi = 100mVrms SRS→ON	f = 1kHz
	Gv3	22		FOCUS→ON (All VOL. = max) (2pin, 41pin)-(18, 24Pin)	f = 20kHz
Output noise voltage	Vno1	5.5	μ Vrms	Rg = 0 (2, 41pin) SRS→OFF, FOCUS→OFF DIN-AUDIO filter	
	Vno2	18		Rg = 0 (2, 41pin) SRS→ON, FOCUS→OFF DIN-AUDIO filter	
	Vno3	50		Rg = 0 (2, 41pin) SRS→ON, FOCUS→ON (All VOL. = max) DIN-AUDIO filter	
Channel separation	CT	-90	dB	Input Side: f = 1kHz, Vi = 0.5Vrms Monitor Side: Rg = 0, IHF-A filter Focus: OFF, SRS: OFF RL=10k Ω	

System Circuit Example

(The following figures show only the side channel.)

1. In the case of SRS 3D stereo is effective for the front speakers.

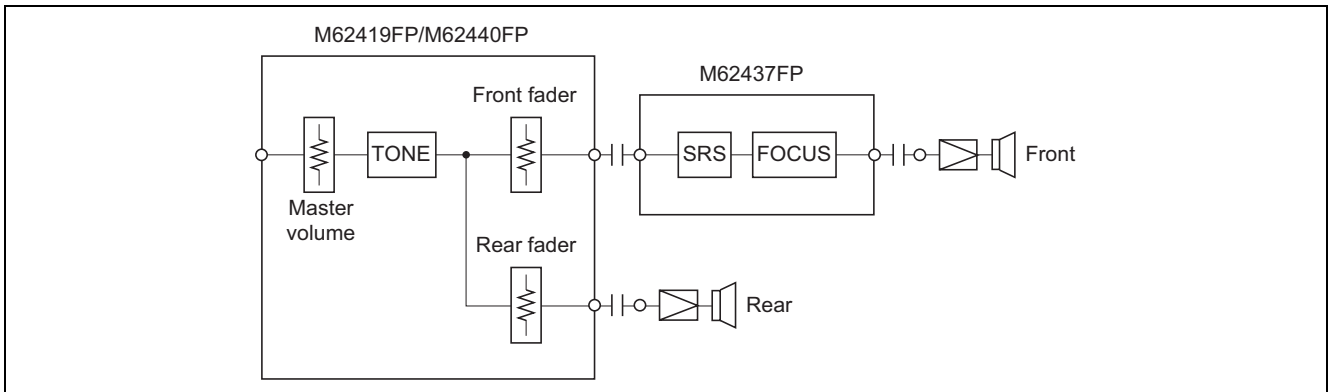

2. In the case of SRS 3D stereo is effective for the front and rear speakers.
(FOCUS is effective for the front speakers.)

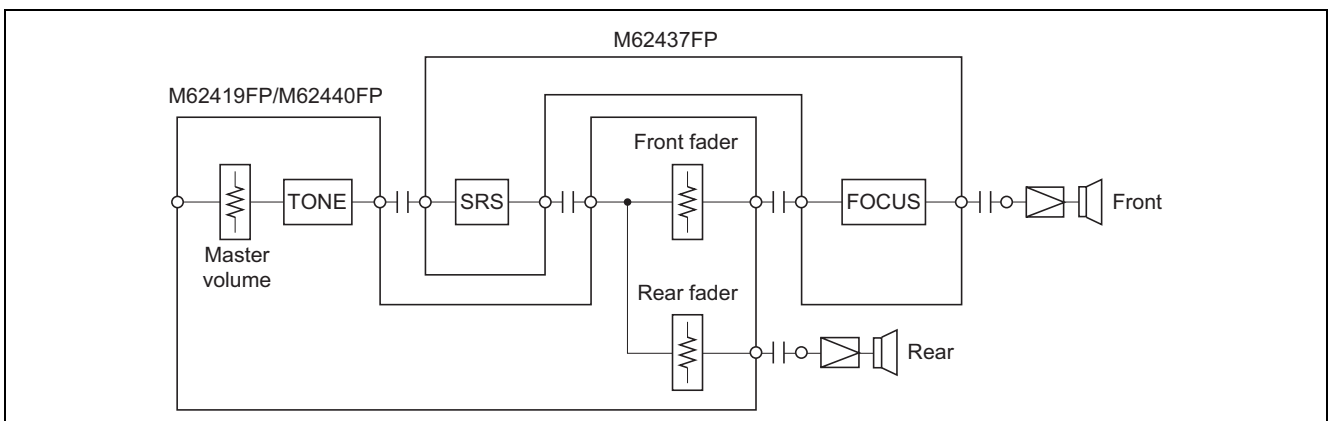

Note

Each switches (SRS ON/OFF, FOCUS ON/OFF and FOCUS Position H/L Switches) does not have the countermeasure for click noise, so that we recommended outside mute circuit.

SRS, the SRS logo, Sound Retrieval System and “everything else is only stereo” are registered trademarks of SRS Labs, Inc.

This device available only to licensees of SRS Lab, Inc.

Licensing and application information may be obtained from SRS Lab, Inc.

Renesas Technology Corp. assumes no responsibility for any damage, or infringement of any third-party’s rights, originating in the use of any product data, diagrams, charts or circuit application examples contained in these materials.

Package Dimensions

42P2R-A



Plastic 42pin 450mil SSOP

EIAJ Package Code	JEDEC Code	Weight(g)	Lead Material
SSOP42-P-450-0.80	—	0.63	Alloy 42/Cu Alloy

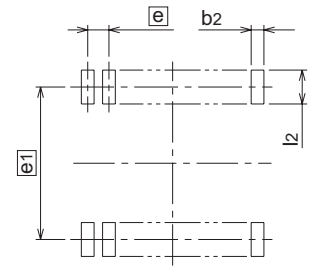
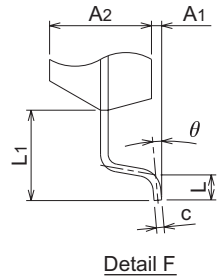
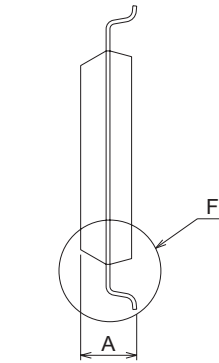
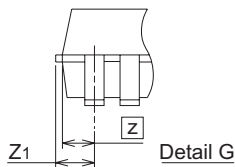
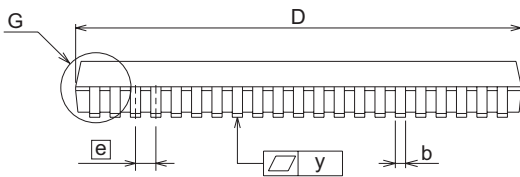
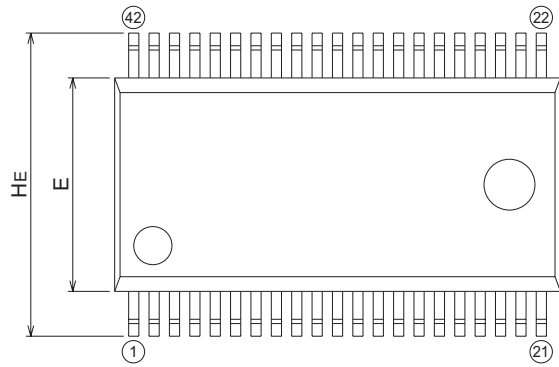

Recommended Mount Pad

Symbol	Dimension in Millimeters		
	Min	Nom	Max
A	—	—	2.4
A1	0.05	—	—
A2	—	2.0	—
b	0.35	0.4	0.5
c	0.13	0.15	0.2
D	17.3	17.5	17.7
E	8.2	8.4	8.6
e	—	0.8	—
HE	11.63	11.93	12.23
L	0.3	0.5	0.7
L1	—	1.765	—
Z	—	0.75	—
Z1	—	—	0.9
y	—	—	0.15
θ	0°	—	10°
b2	—	0.5	—
e1	—	11.43	—
l2	1.27	—	—

Notes:

1. This document is provided for reference purposes only so that Renesas customers may select the appropriate Renesas products for their use. Renesas neither makes warranties or representations with respect to the accuracy or completeness of the information contained in this document nor grants any license to any intellectual property rights or any other rights of Renesas or any third party with respect to the information in this document.
2. Renesas shall have no liability for damages or infringement of any intellectual property or other rights arising out of the use of any information in this document, including, but not limited to, product data, diagrams, charts, programs, algorithms, and application circuit examples.
3. You should not use the products or the technology described in this document for the purpose of military applications such as the development of weapons of mass destruction or for the purpose of any other military use. When exporting the products or technology described herein, you should follow the applicable export control laws and regulations, and procedures required by such laws and regulations.
4. All information included in this document such as product data, diagrams, charts, programs, algorithms, and application circuit examples, is current as of the date this document is issued. Such information, however, is subject to change without any prior notice. Before purchasing or using any Renesas products listed in this document, please confirm the latest product information with a Renesas sales office. Also, please pay regular and careful attention to additional and different information to be disclosed by Renesas such as that disclosed through our website. (<http://www.renesas.com>)
5. Renesas has used reasonable care in compiling the information included in this document, but Renesas assumes no liability whatsoever for any damages incurred as a result of errors or omissions in the information included in this document.
6. When using or otherwise relying on the information in this document, you should evaluate the information in light of the total system before deciding about the applicability of such information to the intended application. Renesas makes no representations, warranties or guarantees regarding the suitability of its products for any particular application and specifically disclaims any liability arising out of the application and use of the information in this document or Renesas products.
7. With the exception of products specified by Renesas as suitable for automobile applications, Renesas products are not designed, manufactured or tested for applications or otherwise in systems the failure or malfunction of which may cause a direct threat to human life or create a risk of human injury or which require especially high quality and reliability such as safety systems, or equipment or systems for transportation and traffic, healthcare, combustion control, aerospace and aeronautics, nuclear power, or undersea communication transmission. If you are considering the use of our products for such purposes, please contact a Renesas sales office beforehand. Renesas shall have no liability for damages arising out of the uses set forth above.
8. Notwithstanding the preceding paragraph, you should not use Renesas products for the purposes listed below:
 - (1) artificial life support devices or systems
 - (2) surgical implantations
 - (3) healthcare intervention (e.g., excision, administration of medication, etc.)
 - (4) any other purposes that pose a direct threat to human lifeRenesas shall have no liability for damages arising out of the uses set forth in the above and purchasers who elect to use Renesas products in any of the foregoing applications shall indemnify and hold harmless Renesas Technology Corp., its affiliated companies and their officers, directors, and employees against any and all damages arising out of such applications.
9. You should use the products described herein within the range specified by Renesas, especially with respect to the maximum rating, operating supply voltage range, movement power voltage range, heat radiation characteristics, installation and other product characteristics. Renesas shall have no liability for malfunctions or damages arising out of the use of Renesas products beyond such specified ranges.
10. Although Renesas endeavors to improve the quality and reliability of its products, IC products have specific characteristics such as the occurrence of failure at a certain rate and malfunctions under certain use conditions. Please be sure to implement safety measures to guard against the possibility of physical injury, and injury or damage caused by fire in the event of the failure of a Renesas product, such as safety design for hardware and software including but not limited to redundancy, fire control and malfunction prevention, appropriate treatment for aging degradation or any other applicable measures. Among others, since the evaluation of microcomputer software alone is very difficult, please evaluate the safety of the final products or system manufactured by you.
11. In case Renesas products listed in this document are detached from the products to which the Renesas products are attached or affixed, the risk of accident such as swallowing by infants and small children is very high. You should implement safety measures so that Renesas products may not be easily detached from your products. Renesas shall have no liability for damages arising out of such detachment.
12. This document may not be reproduced or duplicated, in any form, in whole or in part, without prior written approval from Renesas.
13. Please contact a Renesas sales office if you have any questions regarding the information contained in this document, Renesas semiconductor products, or if you have any other inquiries.



RENESAS SALES OFFICES

<http://www.renesas.com>

Refer to "<http://www.renesas.com/en/network>" for the latest and detailed information.

Renesas Technology America, Inc.
450 Holger Way, San Jose, CA 95134-1368, U.S.A
Tel: <1> (408) 382-7500, Fax: <1> (408) 382-7501

Renesas Technology Europe Limited
Dukes Meadow, Millboard Road, Bourne End, Buckinghamshire, SL8 5FH, U.K.
Tel: <44> (1628) 585-100, Fax: <44> (1628) 585-900

Renesas Technology (Shanghai) Co., Ltd.
Unit 204, 205, AZIACenter, No.1233 Lujiazui Ring Rd, Pudong District, Shanghai, China 200120
Tel: <86> (21) 5877-1818, Fax: <86> (21) 6887-7858/7898

Renesas Technology Hong Kong Ltd.
7th Floor, North Tower, World Finance Centre, Harbour City, Canton Road, Tsimshatsui, Kowloon, Hong Kong
Tel: <852> 2265-6688, Fax: <852> 2377-3473

Renesas Technology Taiwan Co., Ltd.
10th Floor, No.99, Fushing North Road, Taipei, Taiwan
Tel: <886> (2) 2715-2888, Fax: <886> (2) 3518-3399

Renesas Technology Singapore Pte. Ltd.
1 Harbour Front Avenue, #06-10, Keppel Bay Tower, Singapore 098632
Tel: <65> 6213-0200, Fax: <65> 6278-8001

Renesas Technology Korea Co., Ltd.
Kukje Center Bldg. 18th Fl., 191, 2-ka, Hangang-ro, Yongsan-ku, Seoul 140-702, Korea
Tel: <82> (2) 796-3115, Fax: <82> (2) 796-2145

Renesas Technology Malaysia Sdn. Bhd
Unit 906, Block B, Menara Amcorp, Amcorp Trade Centre, No.18, Jln Persiaran Barat, 46050 Petaling Jaya, Selangor Darul Ehsan, Malaysia
Tel: <603> 7955-9390, Fax: <603> 7955-9510