

To our customers,

Old Company Name in Catalogs and Other Documents

On April 1st, 2010, NEC Electronics Corporation merged with Renesas Technology Corporation, and Renesas Electronics Corporation took over all the business of both companies. Therefore, although the old company name remains in this document, it is a valid Renesas Electronics document. We appreciate your understanding.

Renesas Electronics website: <http://www.renesas.com>

April 1st, 2010
Renesas Electronics Corporation

Issued by: Renesas Electronics Corporation (<http://www.renesas.com>)

Send any inquiries to <http://www.renesas.com/inquiry>.

Notice

1. All information included in this document is current as of the date this document is issued. Such information, however, is subject to change without any prior notice. Before purchasing or using any Renesas Electronics products listed herein, please confirm the latest product information with a Renesas Electronics sales office. Also, please pay regular and careful attention to additional and different information to be disclosed by Renesas Electronics such as that disclosed through our website.
2. Renesas Electronics does not assume any liability for infringement of patents, copyrights, or other intellectual property rights of third parties by or arising from the use of Renesas Electronics products or technical information described in this document. No license, express, implied or otherwise, is granted hereby under any patents, copyrights or other intellectual property rights of Renesas Electronics or others.
3. You should not alter, modify, copy, or otherwise misappropriate any Renesas Electronics product, whether in whole or in part.
4. Descriptions of circuits, software and other related information in this document are provided only to illustrate the operation of semiconductor products and application examples. You are fully responsible for the incorporation of these circuits, software, and information in the design of your equipment. Renesas Electronics assumes no responsibility for any losses incurred by you or third parties arising from the use of these circuits, software, or information.
5. When exporting the products or technology described in this document, you should comply with the applicable export control laws and regulations and follow the procedures required by such laws and regulations. You should not use Renesas Electronics products or the technology described in this document for any purpose relating to military applications or use by the military, including but not limited to the development of weapons of mass destruction. Renesas Electronics products and technology may not be used for or incorporated into any products or systems whose manufacture, use, or sale is prohibited under any applicable domestic or foreign laws or regulations.
6. Renesas Electronics has used reasonable care in preparing the information included in this document, but Renesas Electronics does not warrant that such information is error free. Renesas Electronics assumes no liability whatsoever for any damages incurred by you resulting from errors in or omissions from the information included herein.
7. Renesas Electronics products are classified according to the following three quality grades: "Standard", "High Quality", and "Specific". The recommended applications for each Renesas Electronics product depends on the product's quality grade, as indicated below. You must check the quality grade of each Renesas Electronics product before using it in a particular application. You may not use any Renesas Electronics product for any application categorized as "Specific" without the prior written consent of Renesas Electronics. Further, you may not use any Renesas Electronics product for any application for which it is not intended without the prior written consent of Renesas Electronics. Renesas Electronics shall not be in any way liable for any damages or losses incurred by you or third parties arising from the use of any Renesas Electronics product for an application categorized as "Specific" or for which the product is not intended where you have failed to obtain the prior written consent of Renesas Electronics. The quality grade of each Renesas Electronics product is "Standard" unless otherwise expressly specified in a Renesas Electronics data sheets or data books, etc.
 - "Standard": Computers; office equipment; communications equipment; test and measurement equipment; audio and visual equipment; home electronic appliances; machine tools; personal electronic equipment; and industrial robots.
 - "High Quality": Transportation equipment (automobiles, trains, ships, etc.); traffic control systems; anti-disaster systems; anti-crime systems; safety equipment; and medical equipment not specifically designed for life support.
 - "Specific": Aircraft; aerospace equipment; submersible repeaters; nuclear reactor control systems; medical equipment or systems for life support (e.g. artificial life support devices or systems), surgical implantations, or healthcare intervention (e.g. excision, etc.), and any other applications or purposes that pose a direct threat to human life.
8. You should use the Renesas Electronics products described in this document within the range specified by Renesas Electronics, especially with respect to the maximum rating, operating supply voltage range, movement power voltage range, heat radiation characteristics, installation and other product characteristics. Renesas Electronics shall have no liability for malfunctions or damages arising out of the use of Renesas Electronics products beyond such specified ranges.
9. Although Renesas Electronics endeavors to improve the quality and reliability of its products, semiconductor products have specific characteristics such as the occurrence of failure at a certain rate and malfunctions under certain use conditions. Further, Renesas Electronics products are not subject to radiation resistance design. Please be sure to implement safety measures to guard them against the possibility of physical injury, and injury or damage caused by fire in the event of the failure of a Renesas Electronics product, such as safety design for hardware and software including but not limited to redundancy, fire control and malfunction prevention, appropriate treatment for aging degradation or any other appropriate measures. Because the evaluation of microcomputer software alone is very difficult, please evaluate the safety of the final products or system manufactured by you.
10. Please contact a Renesas Electronics sales office for details as to environmental matters such as the environmental compatibility of each Renesas Electronics product. Please use Renesas Electronics products in compliance with all applicable laws and regulations that regulate the inclusion or use of controlled substances, including without limitation, the EU RoHS Directive. Renesas Electronics assumes no liability for damages or losses occurring as a result of your noncompliance with applicable laws and regulations.
11. This document may not be reproduced or duplicated, in any form, in whole or in part, without prior written consent of Renesas Electronics.
12. Please contact a Renesas Electronics sales office if you have any questions regarding the information contained in this document or Renesas Electronics products, or if you have any other inquiries.

(Note 1) "Renesas Electronics" as used in this document means Renesas Electronics Corporation and also includes its majority-owned subsidiaries.

(Note 2) "Renesas Electronics product(s)" means any product developed or manufactured by or for Renesas Electronics.

Block Diagram

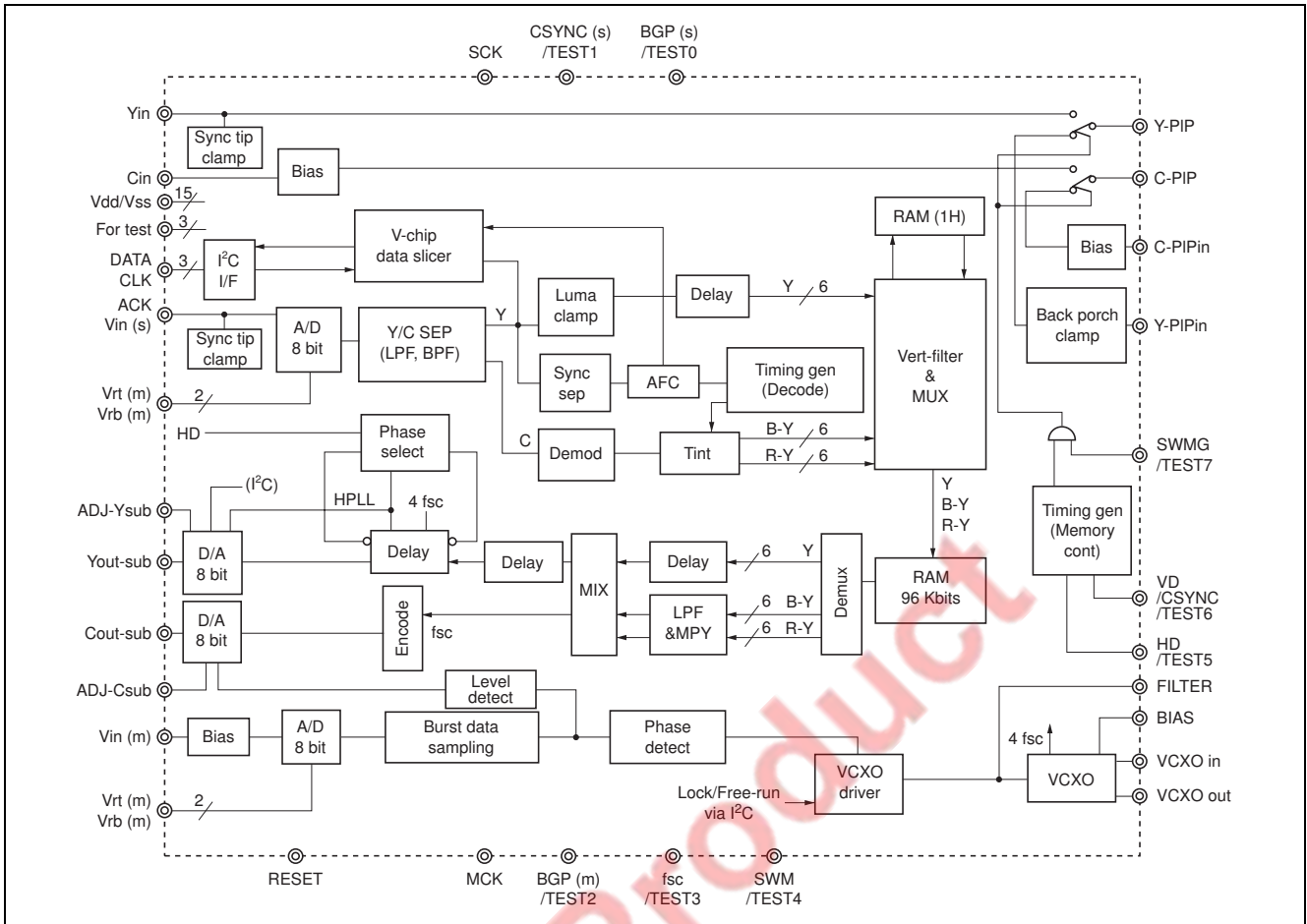

Pin Arrangement

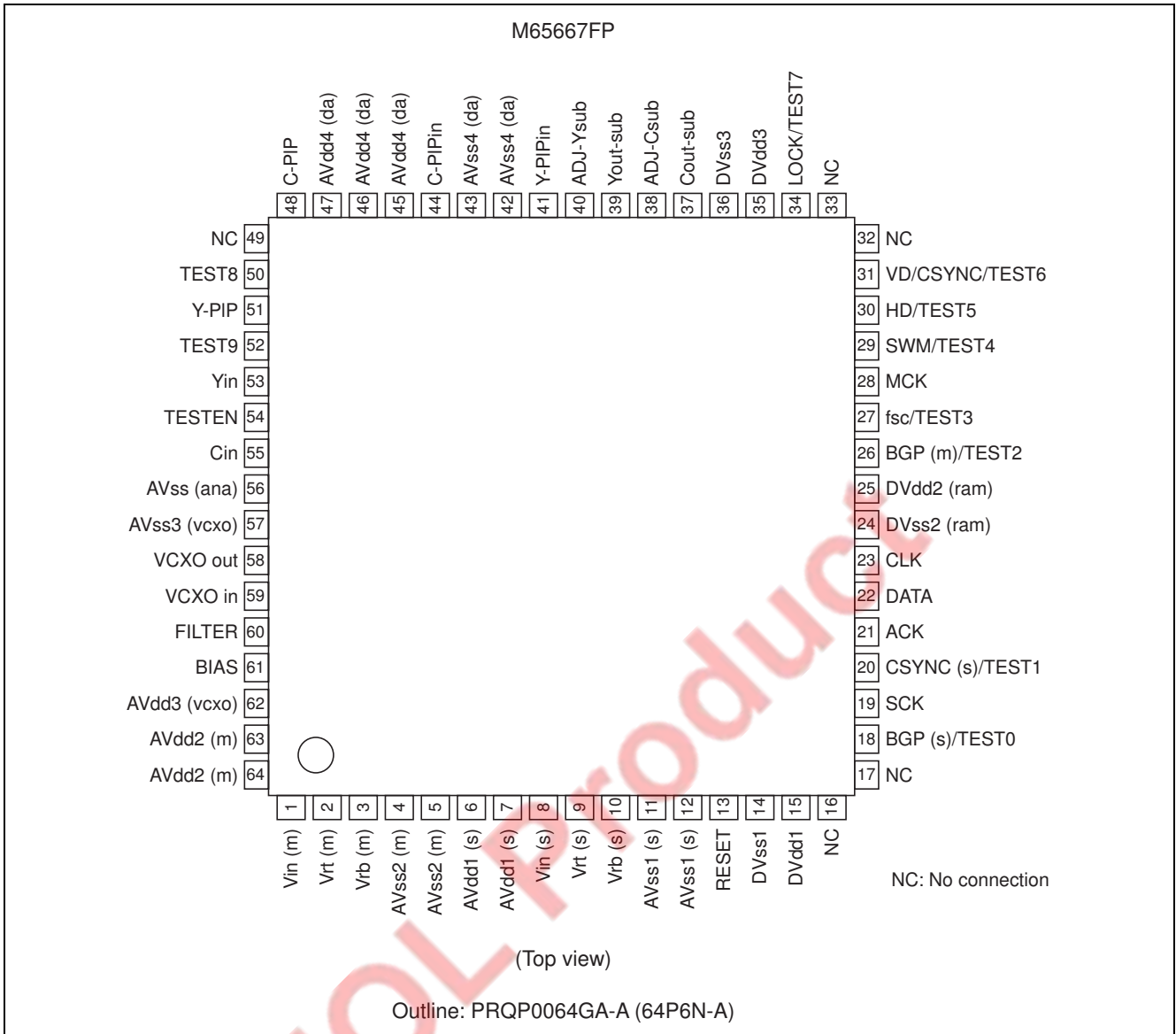

Pin Description

Pin No.	Name	I/O	Function	Remarks
1	Vin (m)	I	Chroma signal input (main-picture)	
2	Vrt (m)	O	A/D Vref+ (main-picture)	
3	Vrb (m)	O	A/D Vref- (main-picture)	
4	AVss2 (m)	GND	Connect to analog GND	
5	AVss2 (m)	GND	Connect to analog GND	
6	AVdd1 (s)	Vdd	Connect to analog power supply	
7	AVdd1 (s)	Vdd	Connect to analog power supply	
8	Vin (s)	I	Composite video signal input (sub-picture)	
9	Vrt (s)	O	A/D Vref+ (sub-picture)	
10	Vrb (s)	O	A/D Vref- (sub-picture)	
11	AVss1 (s)	GND	Connect to analog GND	
12	AVss1 (s)	GND	Connect to analog GND	
13	RESET	I	Power on reset input signal ("L" reset)	100 kΩ to Vdd, 10 μF to GND
14	DVss1	GND	Connect to digital GND	
15	DVdd1	Vdd	Connect to digital power supply	
16	NC	—	No connection	
17	NC	—	No connection	
18	BGP (s) /TEST0	(I) O	For test	Non connect
19	SCK	I	For test (connect to digital GND)	Connect to GND
20	CSYNC (s) /TEST1	I (/O)	For test (connect to digital GND)	Pull down 15 kΩ
21	ACK	O	I ² C bus-data/Acknowledge output signal	
22	DATA	I	I ² C bus-data input signal	
23	CLK	I	I ² C bus-clock input signal	
24	DVss2 (ram)	GND	Connect to digital GND	
25	DVdd2 (ram)	Vdd	Connect to digital power supply	
26	BGP (m) /TEST2	(I) O	For test	Non connect
27	fsc/TEST3	I (/O)	For test (pull down to digital GND by resistor 15 kΩ)	Pull down 15 kΩ
28	MCK	I	For test (connect to digital GND)	Connect to GND
29	SWM/TEST4	(I) O	For test	Non connect
30	HD/TEST5	I (/O)	Horizontal sync input signal (Positive going edge is used)	
31	VD/CSYNC/TEST6	I (/O)	Vertical sync input signal (active "H")	
32	NC	—	No connection	
33	NC	—	No connection	
34	SWMG/TEST7	I (/O)	Enable input signal to display sub picture ("H" enable)	Pull down 15 kΩ
35	DVdd3	Vdd	Connect to digital power supply	
36	DVss3	GND	Connect to digital GND	
37	Cout-sub	O	D/A output signal (Chroma signal of sub-picture)	
38	ADJ-Csob	I	D/A adjust for chroma signal (sub-picture)	
39	Yout-sub	O	D/A output signal (Luma signal of sub-picture)	
40	ADJ-Ysub	I	D/A adjust for luma signal (sub-picture)	
41	Y-PIPin	I	PIP luma signal re-input	
42	AVss4 (da)	GND	Connects to analog GND	
43	AVss4 (da)	GND	Connects to analog GND	
44	C-PIPin	I	PIP chroma signal re-input	
45	AVdd4 (da)	Vdd	Connect to analog power supply	
46	AVdd4 (da)	Vdd	Connect to analog power supply	
47	AVdd4 (da)	Vdd	Connect to analog power supply	
48	C-PIP	O	PIP chroma signal output	

Pin Description (cont.)

Pin No.	Name	I/O	Function	Remarks
49	NC	—	No connection	
50	TEST8	I	For test (connect to analog GND)	Pull up 15 k Ω
51	Y-PIP	O	PIP luma signal output	
52	TEST9	I	For test (connect to analog GND)	Connect to GND
53	Yin	I	Luma input signal (main-picture)	
54	TESTEN	I	For test (connect to analog GND)	Connect to GND
55	Cin	I	Chroma input signal (main-picture)	
56	AVss (ana)	GND	Connect to analog GND	
57	AVss3 (vcxo)	GND	Connects to analog GND	
58	VCXO out	O	VCXO output signal	
59	VCXO in	I	VCXO input signal	
60	FILTER	I	Filter	
61	BIAS	O	Bias	
62	AVdd3 (vcxo)	Vdd	Connect to analog power supply	
63	AVdd2 (m)	Vdd	Connect to analog power supply	
64	AVdd2 (m)	Vdd	Connect to analog power supply	

EOL Product

Absolute Maximum Ratings

(V_{SS} = 0 V)

Item	Symbol	Limits		Unit
		Min	Max	
Supply voltage (3.3 V)	V _{DD3}	-0.3	4.6	V
Input voltage	V _I	-0.3	V _{DD3} + 0.3	V
Output voltage	V _O	-0.3	V _{DD3} + 0.3	V
Output current ^{Note1}	I _O	—	I _{OL} = 20 I _{OH} = -26	mA
Power dissipation	P _d	—	1400	mW
Operating temperature	T _{opr}	-20	75	°C
Storage temperature	T _{stg}	-50	125	°C

Note: 1. Output current per output terminal. But P_d limits all current.

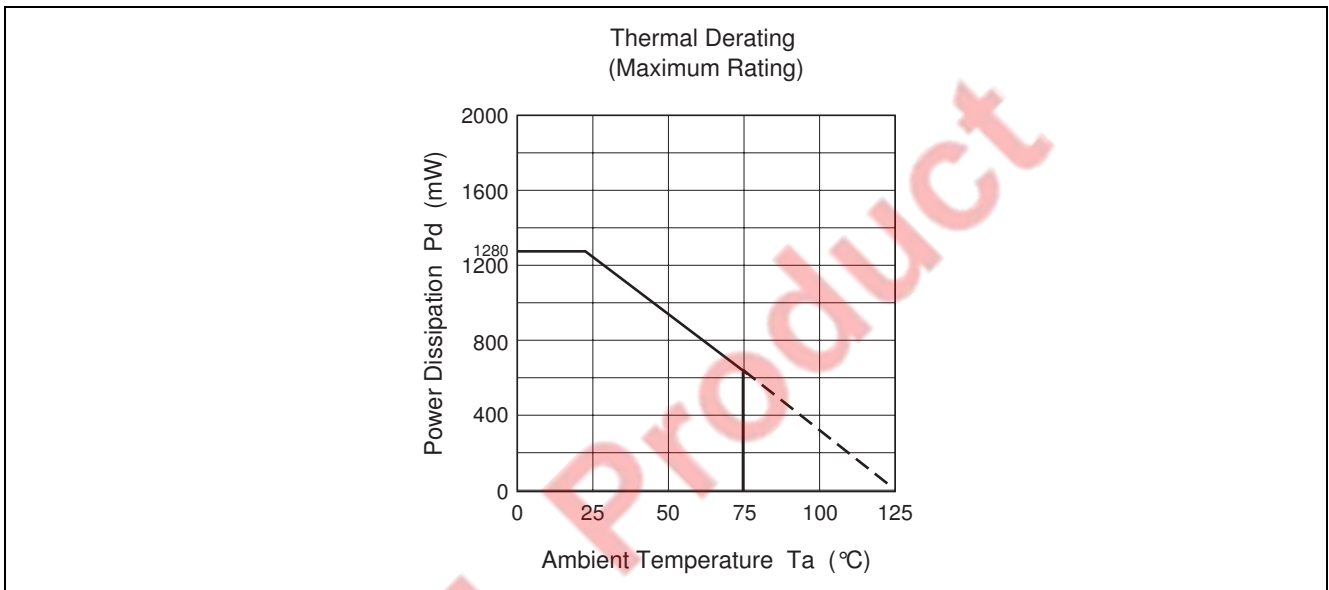

DC Characteristics

(Ta = 25°C, unless otherwise noted, Vss = 0 V)

Item	Symbol	Limits			Unit	Test Conditions	
		Min	Typ	Max			
Input voltage (CMOS interface)	L	V _{IL}	0	—	0.81	V	V _{DD} = 2.7 V
	H	V _{IH}	2.52	—	3.6	V	V _{DD} = 3.6 V
Input voltage schmitt trigger (CMOS interface)	—	V _{T-}	0.5	—	1.65	V	V _{DD} = 3.3V
	+	V _{T+}	1.4	—	2.4	V	
	Hysteresis	V _H	0.3	—	1.2	V	
Output voltage	L	V _{OL}	—	—	0.05	V	V _{DD} = 3.3 V, I _O < 1 μA
	H	V _{OH}	3.25	—	—	V	
Output current	L	I _{OL}	4	—	—	mA	V _{DD} = 3.0 V, V _{OL} = 0.4 V
	H	I _{OH}	—	—	-4	mA	V _{DD} = 3.0 V, V _{OH} = 2.6 V
Input current	L	I _{IL}	-1	—	1	μA	V _{DD} = 3.6 V, V _I = 0 V
	H	I _{IH}	-1	—	1	μA	V _{DD} = 3.6 V, V _I = 3.6 V
Output leakage current	L	I _{OZL}	-1	—	1	μA	V _{DD} = 3.6 V, V _O = 0 V
	H	I _{OZH}	-1	—	1	μA	V _{DD} = 3.6 V, V _O = 3.6 V
Input pin capacitance		C _I	—	7	15	pF	f = 1 MHz, V _{DD} = 0 V
Output pin capacitance		C _O	—	7	15	pF	
Bidirectional pin capacitance		C _{IO}	—	7	15	pF	
Operating current	3.3 V supply	I _{DD}	—	—	140	mA	

PIP TV System Block Diagram

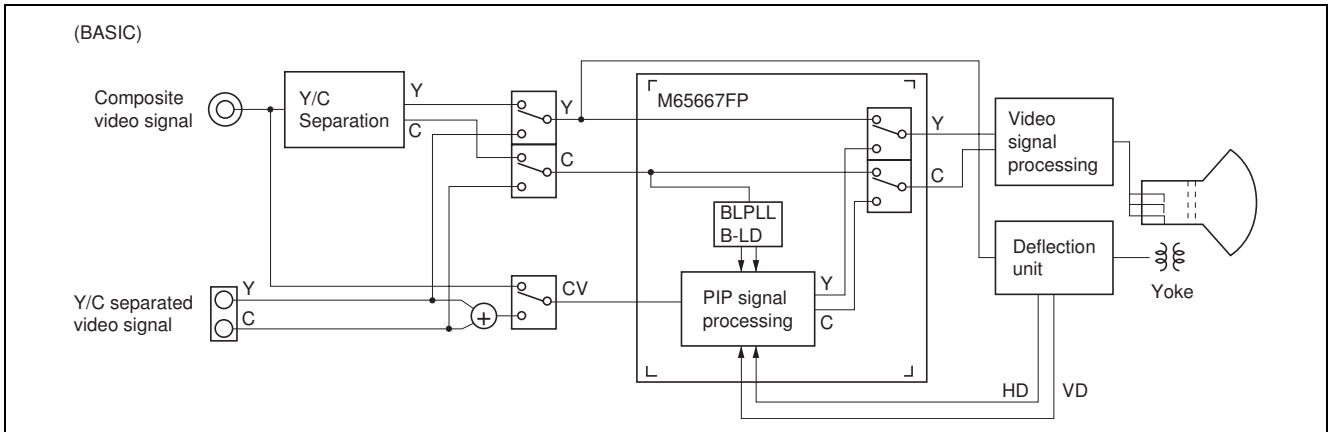

Driving Method and Operating Specification for Serial Interface Data

(1) Serial data transmission completion and start

A low-to-high transition of the DATA (serial data) line while the CLK (serial clock) is high, that completes the serial transmission and makes the bus free.

A high-to-low transition of the DATA line while the CLK is high, that starts the serial transmission and waits for the following CLK and DATA inputs.

(2) Serial data transmission

The data are transmitted in the most significant bit (MSB) first by one-byte unit on the DATA line successively. One-byte data transmission is completed by 9 clock cycles, the former 8 cycles are for address/data and the latter one is for acknowledge detection. (In reading state, ACK is "H" under these two conditions;

1. The coincidence of two address data for the address data transmission.
2. The completion of 8-bit setting data transfer. In writing state, ACK is "H" with the address coincidence and ACK is "L" for detecting acknowledge input from the master (micro processor) after sending 8-bit setting data).

For address/data transmission, DATA must change while CLK is "L". (The data change while CLK is "H" or the simultaneous change of CLK and DATA, that will be a false operation because of undistinguished condition from the completion/start of serial data transfer.)

After the beginning of serial data transmission, the total number of data bytes that can be transferred are not limited.

(3) The byte format of data transmission (The sequence of data transmission)

1. The byte format during data setting to M65667FP are shown as follows.

In right after the forming of serial data transmitting state, the slave address 24h (00100100b) is transferred. Afterwards, the internal register address (1 byte) and setting data (by 1 byte unit) are transferred successively. Several bytes of setting data can be handled in the one transmission. In this operation, the setting data are written into the address register whose address is increased one in initially transferred internal register address. (The next address of 7Fh, it returns to 00h.)

2. The byte format during data reading from M65667FP are shown as follows.

Before data reading from M65667FP, whose internal address need to be set by the data reading/transmitting. After the data reading/transmitting, the operation of "serial data transmission completion and start" (described in (1)) is necessary. Continuously, the slave address 25h (00100101b) is sent, and then the inverted read out data are available on ACK. Several bytes of writing data can be handled in the one transmission, too. In this operation, the setting data also are written into the address register whose address is increased one in initially transferred internal register address. (The next address of 7Fh, it returns to 00h.)

The Examples of Serial Byte Transmission Format

(1) The writing operation of the setting data (AAh) into M65667FP internal address of 00h

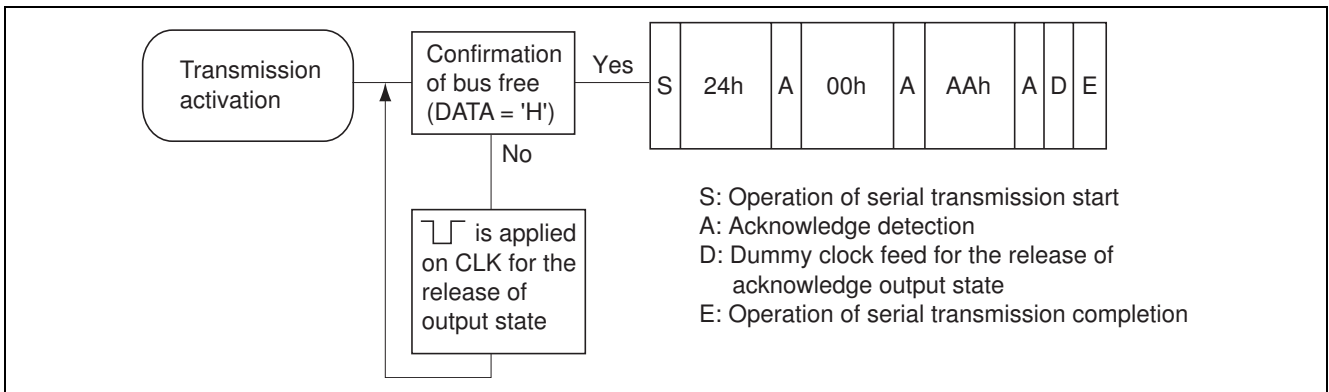

(2) The writing operation of the setting data (FFh, 80h, EEh) into M65667FP internal address of 04h to 06h

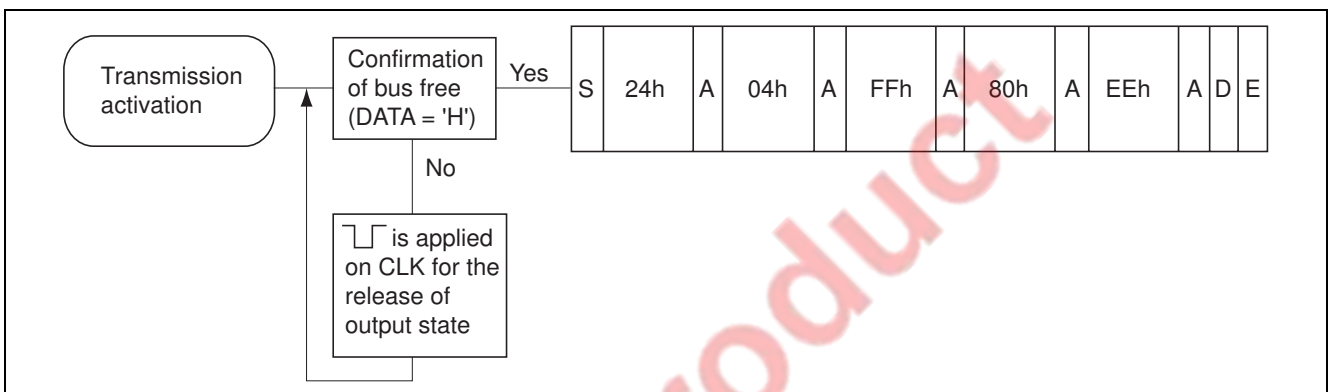

(3) The reading operation of the setting data from M65667FP internal address of 00h

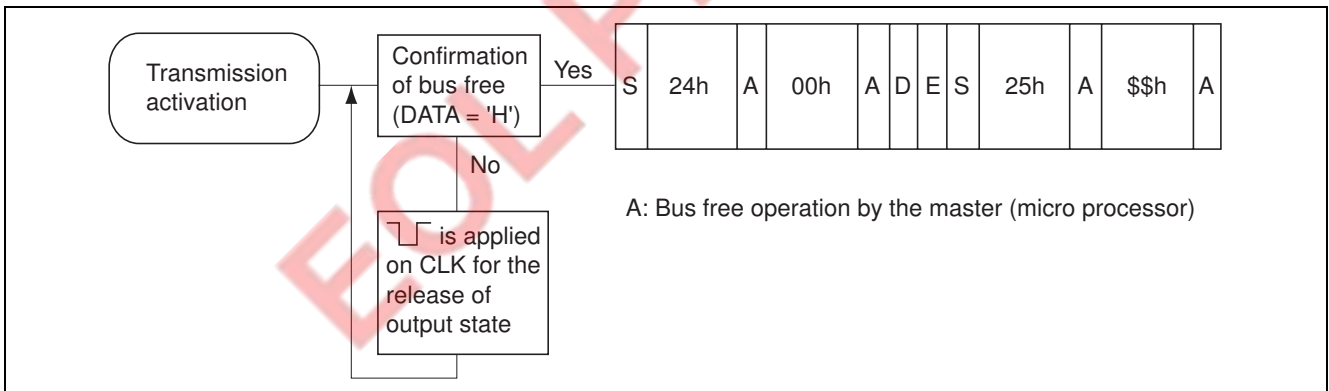

(4) The reading operation of the setting data from M65667FP internal address of 04h to 06h

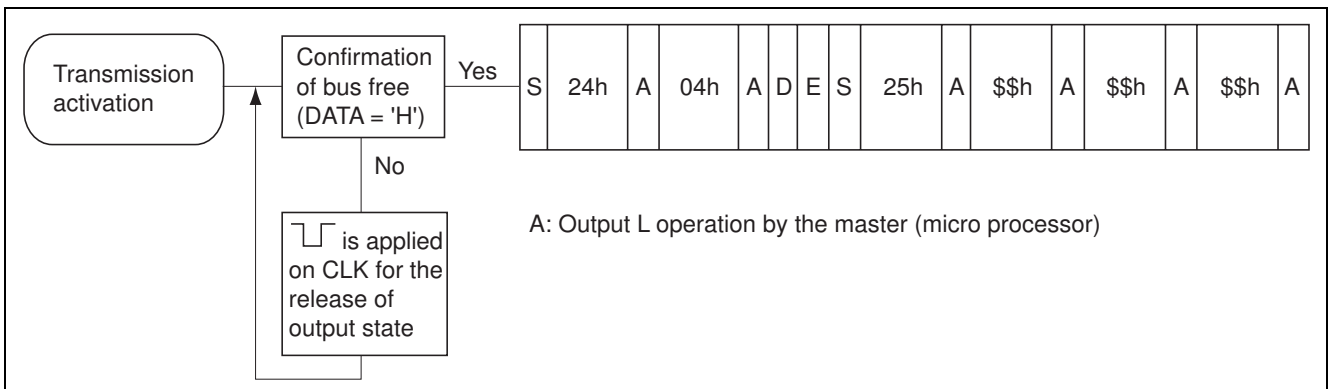

Timing Diagram

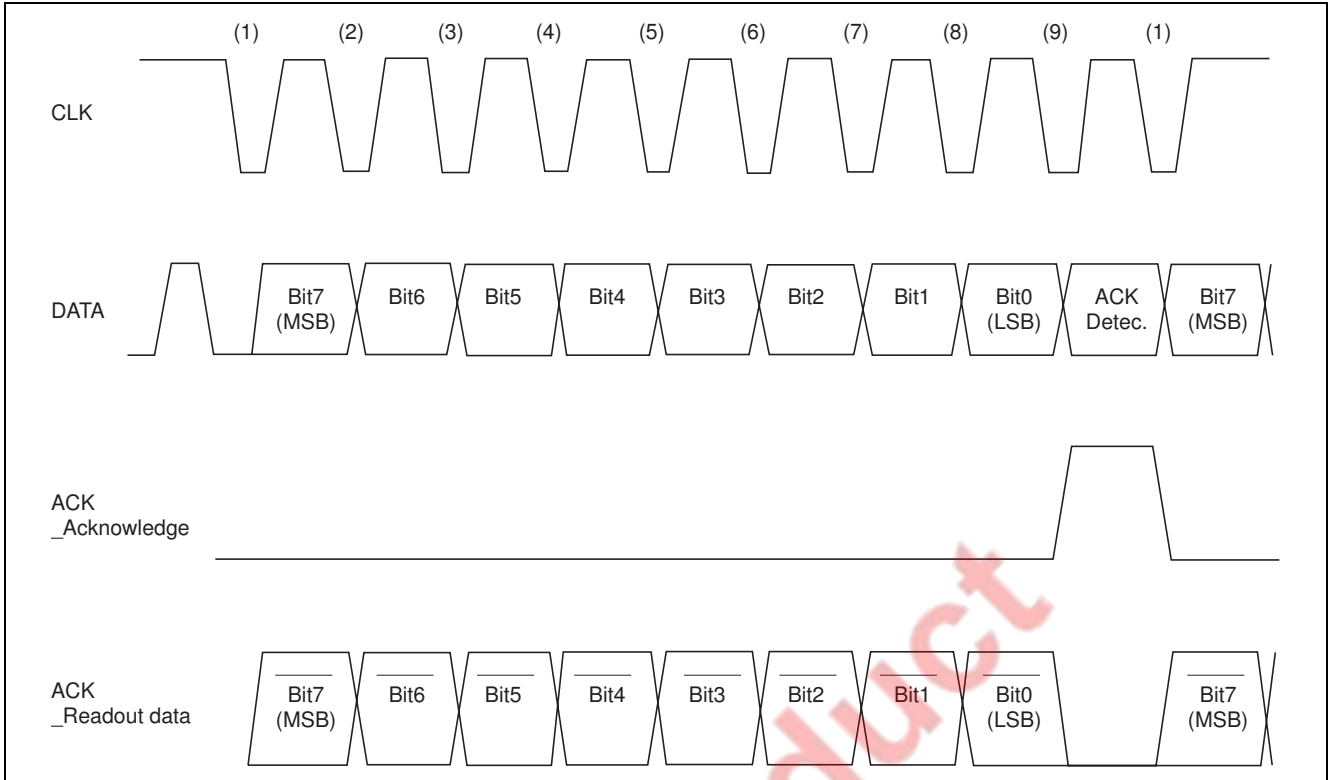

Package Dimensions

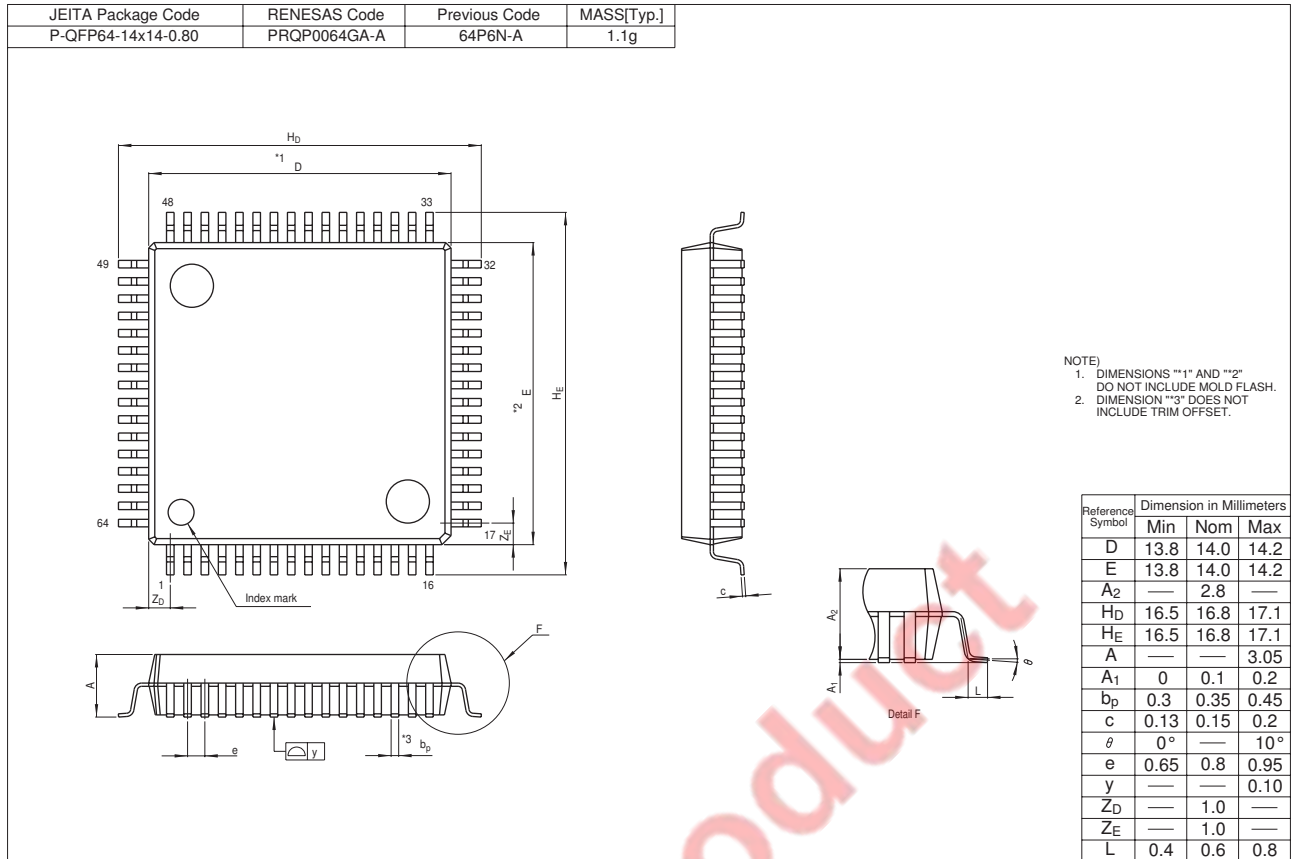

EOL Product

Notes:

1. This document is provided for reference purposes only so that Renesas customers may select the appropriate Renesas products for their use. Renesas neither makes warranties or representations with respect to the accuracy or completeness of the information contained in this document nor grants any license to any intellectual property rights or any other rights of Renesas or any third party with respect to the information in this document.
2. Renesas shall have no liability for damages or infringement of any intellectual property or other rights arising out of the use of any information in this document, including, but not limited to, product data, diagrams, charts, programs, algorithms, and application circuit examples.
3. You should not use the products or the technology described in this document for the purpose of military applications such as the development of weapons of mass destruction or for the purpose of any other military use. When exporting the products or technology described herein, you should follow the applicable export control laws and regulations, and procedures required by such laws and regulations.
4. All information included in this document such as product data, diagrams, charts, programs, algorithms, and application circuit examples, is current as of the date this document is issued. Such information, however, is subject to change without any prior notice. Before purchasing or using any Renesas products listed in this document, please confirm the latest product information with a Renesas sales office. Also, please pay regular and careful attention to additional and different information to be disclosed by Renesas such as that disclosed through our website. (<http://www.renesas.com>)
5. Renesas has used reasonable care in compiling the information included in this document, but Renesas assumes no liability whatsoever for any damages incurred as a result of errors or omissions in the information included in this document.
6. When using or otherwise relying on the information in this document, you should evaluate the information in light of the total system before deciding about the applicability of such information to the intended application. Renesas makes no representations, warranties or guarantees regarding the suitability of its products for any particular application and specifically disclaims any liability arising out of the application and use of the information in this document or Renesas products.
7. With the exception of products specified by Renesas as suitable for automobile applications, Renesas products are not designed, manufactured or tested for applications or otherwise in systems the failure or malfunction of which may cause a direct threat to human life or create a risk of human injury or which require especially high quality and reliability such as safety systems, or equipment or systems for transportation and traffic, healthcare, combustion control, aerospace and aeronautics, nuclear power, or undersea communication transmission. If you are considering the use of our products for such purposes, please contact a Renesas sales office beforehand. Renesas shall have no liability for damages arising out of the uses set forth above.
8. Notwithstanding the preceding paragraph, you should not use Renesas products for the purposes listed below:
 - (1) artificial life support devices or systems
 - (2) surgical implantations
 - (3) healthcare intervention (e.g., excision, administration of medication, etc.)
 - (4) any other purposes that pose a direct threat to human lifeRenesas shall have no liability for damages arising out of the uses set forth in the above and purchasers who elect to use Renesas products in any of the foregoing applications shall indemnify and hold harmless Renesas Technology Corp., its affiliated companies and their officers, directors, and employees against any and all damages arising out of such applications.
9. You should use the products described herein within the range specified by Renesas, especially with respect to the maximum rating, operating supply voltage range, movement power voltage range, heat radiation characteristics, installation and other product characteristics. Renesas shall have no liability for malfunctions or damages arising out of the use of Renesas products beyond such specified ranges.
10. Although Renesas endeavors to improve the quality and reliability of its products, IC products have specific characteristics such as the occurrence of failure at a certain rate and malfunctions under certain use conditions. Please be sure to implement safety measures to guard against the possibility of physical injury, and injury or damage caused by fire in the event of the failure of a Renesas product, such as safety design for hardware and software including but not limited to redundancy, fire control and malfunction prevention, appropriate treatment for aging degradation or any other applicable measures. Among others, since the evaluation of microcomputer software alone is very difficult, please evaluate the safety of the final products or system manufactured by you.
11. In case Renesas products listed in this document are detached from the products to which the Renesas products are attached or affixed, the risk of accident such as swallowing by infants and small children is very high. You should implement safety measures so that Renesas products may not be easily detached from your products. Renesas shall have no liability for damages arising out of such detachment.
12. This document may not be reproduced or duplicated, in any form, in whole or in part, without prior written approval from Renesas.
13. Please contact a Renesas sales office if you have any questions regarding the information contained in this document, Renesas semiconductor products, or if you have any other inquiries.



RENESAS SALES OFFICES

<http://www.renesas.com>

Refer to "<http://www.renesas.com/en/network>" for the latest and detailed information.

Renesas Technology America, Inc.
450 Holger Way, San Jose, CA 95134-1368, U.S.A
Tel: <1> (408) 382-7500, Fax: <1> (408) 382-7501

Renesas Technology Europe Limited
Dukes Meadow, Millboard Road, Bourne End, Buckinghamshire, SL8 5FH, U.K.
Tel: <44> (1628) 585-100, Fax: <44> (1628) 585-900

Renesas Technology (Shanghai) Co., Ltd.
Unit 204, 205, AZIACenter, No.1233 Lujiazui Ring Rd, Pudong District, Shanghai, China 200120
Tel: <86> (21) 5877-1818, Fax: <86> (21) 6887-7858/7898

Renesas Technology Hong Kong Ltd.
7th Floor, North Tower, World Finance Centre, Harbour City, Canton Road, Tsimshatsui, Kowloon, Hong Kong
Tel: <852> 2265-6688, Fax: <852> 2377-3473

Renesas Technology Taiwan Co., Ltd.
10th Floor, No.99, Fushing North Road, Taipei, Taiwan
Tel: <886> (2) 2715-2888, Fax: <886> (2) 3518-3399

Renesas Technology Singapore Pte. Ltd.
1 Harbour Front Avenue, #06-10, Keppel Bay Tower, Singapore 098632
Tel: <65> 6213-0200, Fax: <65> 6278-8001

Renesas Technology Korea Co., Ltd.
Kukje Center Bldg. 18th Fl., 191, 2-ka, Hangang-ro, Yongsan-ku, Seoul 140-702, Korea
Tel: <82> (2) 796-3115, Fax: <82> (2) 796-2145

Renesas Technology Malaysia Sdn. Bhd
Unit 906, Block B, Menara Amcorp, Amcorp Trade Centre, No.18, Jln Persiaran Barat, 46050 Petaling Jaya, Selangor Darul Ehsan, Malaysia
Tel: <603> 7955-9390, Fax: <603> 7955-9510