

## 1. Overview

### 1.1 Features

The R8C/L35C Group, R8C/L36C Group, R8C/L38C Group, and R8C/L3AC Group of single-chip MCUs incorporate the R8C CPU core, which implements a powerful instruction set for a high level of efficiency and supports a 1 Mbyte address space, allowing execution of instructions at high speed. In addition, the CPU core integrates a multiplier for high-speed operation processing.

Power consumption is low, and the supported operating modes allow additional power control. These MCUs are designed to maximize EMI/EMS performance.

Integration of many peripheral functions, including multifunction timer and serial interface, helps reduce the number of system components.

These groups have data flash (1 KB × 4 blocks) with the background operation (BGO) function.

#### 1.1.1 Applications

Household appliances, office equipment, audio equipment, consumer products, etc.

## 1.1.2 Differences between Groups

Table 1.1 lists the Differences between Groups, Table 1.2 lists the Programmable I/O Ports Provided for Each Group, and Table 1.3 lists the LCD Display Function Pins Provided for Each Group. Figures 1.9 to 1.13 show the Pin Assignment for Each Group, and Tables 1.7 to 1.10 list Product Information.

The explanations in the chapters which follow apply to the R8C/L3AC Group only. Note the differences shown below.

**Table 1.1 Differences between Groups**

Item	Function	R8C/L35C Group	R8C/L36C Group	R8C/L38C Group	R8C/L3AC Group
I/O Ports	Programmable I/O ports	41 pins	52 pins	68 pins	88 pins
	High current drive ports	5 pins	8 pins	8 pins	16 pins
Interrupts	$\overline{\text{INT}}$ interrupt pins	5 pins	8 pins	8 pins	8 pins
	Key input interrupt pins	4 pins	4 pins	8 pins	8 pins
Timer RA	Timer RA output pin	None	1 pin	1 pin	1 pin
Timer RB	Timer RB output pin	None	1 pin	1 pin	1 pin
Timer RD	Timer RD I/O pin	None	None	8 pins	8 pins
Timer RE	Timer RE output pin	None	1 pin	1 pin	1 pin
Timer RG	Timer RG I/O pin	None	None	None	2 pins
	Timer RG output pin	None	None	None	2 pins
A/D Converter	Analog input pin	10 pins	10 pins	16 pins	20 pins
LCD Drive Control Circuit	LCD power supply	3 pins (VL1, VL2, VL4)	4 pins (VL1 to VL4)	4 pins (VL1 to VL4)	4 pins (VL1 to VL4)
	Common output pins	Max. 4 pins	Max. 8 pins	Max. 8 pins	Max. 8 pins
	Segment output pins	Max. 24 pins	Max. 32 pins	Max. 48 pins	Max. 56 pins
Packages		52-pin LQFP	64-pin LQFP	80-pin LQFP	100-pin LQFP/ 100-pin QFP

Note:

- I/O ports are shared with I/O functions, such as interrupts or timers.  
Refer to **Tables 1.11 to 1.13, Pin Name Information by Pin Number**, for details.

**Table 1.2 Programmable I/O Ports Provided for Each Group**

Programmable I/O Port	R8C/L35C Group Total: 41 I/O pins								R8C/L36C Group Total: 52 I/O pins								R8C/L38C Group Total: 68 I/O pins								R8C/L3AC Group Total: 88 I/O pins							
	bit 7	bit 6	bit 5	bit 4	bit 3	bit 2	bit 1	bit 0	bit 7	bit 6	bit 5	bit 4	bit 3	bit 2	bit 1	bit 0	bit 7	bit 6	bit 5	bit 4	bit 3	bit 2	bit 1	bit 0	bit 7	bit 6	bit 5	bit 4	bit 3	bit 2	bit 1	bit 0
P0	✓	✓	✓	✓	✓	✓	✓	✓	✓	✓	✓	✓	✓	✓	✓	✓	✓	✓	✓	✓	✓	✓	✓	✓	✓	✓	✓	✓	✓	✓	✓	
P1	-	-	-	-	-	-	-	-	-	-	-	-	-	-	-	-	-	-	-	✓	✓	✓	✓	✓	✓	✓	✓	✓	✓	✓		
P2	✓	✓	✓	✓	-	-	-	-	✓	✓	✓	✓	-	-	-	-	✓	✓	✓	✓	✓	✓	✓	✓	✓	✓	✓	✓	✓	✓		
P3	-	-	-	-	✓	✓	✓	✓	✓	✓	✓	✓	✓	✓	✓	✓	✓	✓	✓	✓	✓	✓	✓	✓	✓	✓	✓	✓	✓	✓		
P4	✓	✓	✓	✓	✓	✓	✓	✓	✓	✓	✓	✓	✓	✓	✓	✓	✓	✓	✓	✓	✓	✓	✓	✓	✓	✓	✓	✓	✓	✓		
P5	-	-	-	-	-	-	-	-	-	-	-	-	-	-	-	-	-	-	-	-	-	-	-	-	-	-	-	-	-	-		
P6	-	-	-	-	-	-	-	-	-	-	-	-	-	-	-	-	✓	✓	✓	✓	✓	✓	✓	✓	✓	✓	✓	✓	✓	✓		
P7	✓	✓	✓	✓	-	-	-	-	✓	✓	✓	✓	✓	✓	✓	✓	✓	✓	✓	✓	✓	✓	✓	✓	✓	✓	✓	✓	✓	✓		
P10	-	-	-	-	-	-	-	-	-	-	-	-	-	-	-	-	-	-	-	-	-	-	-	-	✓	✓	✓	✓	✓	✓		
P11	-	-	-	✓	✓	✓	✓	✓	✓	✓	✓	✓	✓	✓	✓	✓	✓	✓	✓	✓	✓	✓	✓	✓	✓	✓	✓	✓	✓	✓		
P12	-	-	-	-	✓	✓	✓	✓	-	-	-	-	-	-	-	-	-	-	-	-	-	-	-	-	-	-	-	✓	✓	✓		
P13	-	-	-	-	✓	✓	✓	✓	-	-	-	-	-	-	-	-	-	-	-	-	-	-	-	-	-	-	-	✓	✓	✓		

Notes:

- The symbol “✓” indicates a programmable I/O port.
- The symbol “-” indicates the settings should be made as follows:
  - Set 1 to the corresponding bits in the PDi (i = 1 to 3, 5 to 7, and 10 to 13) register.
  - Set 0 to the corresponding bits in the Pi (i = 1 to 3, 5 to 7, and 10 to 13) register.
  - Set 0 to the corresponding bits in the P10DRR or P11DRR register.

**Table 1.3 LCD Display Function Pins Provided for Each Group**

Shared I/O Port	L35C Group Common output: Max. 4 Segment output: Max. 24								L36C Group Common output: Max. 8 Segment output: Max. 32								L38C Group Common output: Max. 8 Segment output: Max. 48								L3AC Group Common output: Max. 8 Segment output: Max. 56							
	SEG 7	SEG 6	SEG 5	SEG 4	SEG 3	SEG 2	SEG 1	SEG 0	SEG 7	SEG 6	SEG 5	SEG 4	SEG 3	SEG 2	SEG 1	SEG 0	SEG 7	SEG 6	SEG 5	SEG 4	SEG 3	SEG 2	SEG 1	SEG 0	SEG 7	SEG 6	SEG 5	SEG 4	SEG 3	SEG 2	SEG 1	SEG 0
P0	SEG 7	SEG 6	SEG 5	SEG 4	SEG 3	SEG 2	SEG 1	SEG 0	SEG 7	SEG 6	SEG 5	SEG 4	SEG 3	SEG 2	SEG 1	SEG 0	SEG 7	SEG 6	SEG 5	SEG 4	SEG 3	SEG 2	SEG 1	SEG 0	SEG 7	SEG 6	SEG 5	SEG 4	SEG 3	SEG 2	SEG 1	SEG 0
P1	-	-	-	-	-	-	-	-	-	-	-	-	-	-	-	-	-	-	-	-	SEG 11	SEG 10	SEG 9	SEG 8	SEG 7	SEG 6	SEG 5	SEG 4	SEG 3	SEG 2	SEG 1	SEG 0
P2	SEG 23	SEG 22	SEG 21	SEG 20	-	-	-	-	SEG 23	SEG 22	SEG 21	SEG 20	-	-	-	-	SEG 23	SEG 22	SEG 21	SEG 20	SEG 19	SEG 18	SEG 17	SEG 16	SEG 15	SEG 14	SEG 13	SEG 12	SEG 11	SEG 10	SEG 9	SEG 8
P3	-	-	-	-	SEG 27	SEG 26	SEG 25	SEG 24	SEG 31	SEG 30	SEG 29	SEG 28	SEG 27	SEG 26	SEG 25	SEG 24	SEG 31	SEG 30	SEG 29	SEG 28	SEG 27	SEG 26	SEG 25	SEG 24	SEG 31	SEG 30	SEG 29	SEG 28	SEG 27	SEG 26	SEG 25	SEG 24
P4	SEG 39	SEG 38	SEG 37	SEG 36	SEG 35	SEG 34	SEG 33	SEG 32	SEG 39	SEG 38	SEG 37	SEG 36	SEG 35	SEG 34	SEG 33	SEG 32	SEG 39	SEG 38	SEG 37	SEG 36	SEG 35	SEG 34	SEG 33	SEG 32	SEG 39	SEG 38	SEG 37	SEG 36	SEG 35	SEG 34	SEG 33	SEG 32
P5	-	-	-	-	-	-	-	-	-	-	-	-	-	-	-	-	-	-	-	-	-	-	-	-	-	-	-	-	-	-	-	-
P6	-	-	-	-	-	-	-	-	-	-	-	-	-	-	-	-	SEG 51	SEG 50	SEG 49	SEG 48	SEG 47	SEG 46	SEG 45	SEG 44	SEG 51	SEG 50	SEG 49	SEG 48	SEG 47	SEG 46	SEG 45	SEG 44
P7	COM 0	COM 1	COM 2	COM 3	-	-	-	-	COM 0	COM 1	COM 2	COM 3	SEG 55	SEG 54	SEG 53	SEG 52	COM 0	COM 1	COM 2	COM 3	SEG 55	SEG 54	SEG 53	SEG 52	COM 0	COM 1	COM 2	COM 3	SEG 55	SEG 54	SEG 53	SEG 52
P12	-	-	-	-	CL2	CL1	-	-	-	-	-	-	CL2	CL1	-	-	-	-	-	-	-	-	-	-	-	-	-	-	-	-	-	-
-	VL1								VL1								VL1								VL1							
-	VL2								VL2								VL2								VL2							
-	-								VL3								VL3								VL3							
-	VL4								VL4								VL4								VL4							

Notes:

- The symbol “-” indicates there is no LCD display function. Set the corresponding bits in registers LSE1 to LSE3, LSE5 to LSE7 to 0 for these pins.
- SEG52 to SEG55 can be used as COM7 to COM4.  
The R8C/L35C Group does not have pins SEG52 to SEG55, so 1/8 duty cannot be selected.
- The R8C/L35C Group does not have the VL3 pin, so 1/4 bias cannot be selected. When the internal voltage multiplier is used, 1/2 bias cannot also be selected.

### 1.1.3 Specifications

Tables 1.4 to 1.6 list the Specifications.

**Table 1.4 Specifications (1)**

Item	Function		Specification
CPU	Central processing unit		R8C CPU core <ul style="list-style-type: none"> <li>• Number of fundamental instructions: 89</li> <li>• Minimum instruction execution time:               <ul style="list-style-type: none"> <li>50 ns (<math>f(XIN) = 20</math> MHz, <math>VCC = 2.7</math> to <math>5.5</math> V)</li> <li>200 ns (<math>f(XIN) = 5</math> MHz, <math>VCC = 1.8</math> to <math>5.5</math> V)</li> </ul> </li> <li>• Multiplier: 16 bits <math>\times</math> 16 bits <math>\rightarrow</math> 32 bits</li> <li>• Multiply-accumulate instruction: 16 bits <math>\times</math> 16 bits + 32 bits <math>\rightarrow</math> 32 bits</li> <li>• Operating mode: Single-chip mode (address space: 1 Mbyte)</li> </ul>
Memory	ROM/RAM Data flash		Refer to <b>Tables 1.7 to 1.10 Product Lists</b> .
Power Supply Voltage Detection	Voltage detection circuit		<ul style="list-style-type: none"> <li>• Power-on reset</li> <li>• Voltage detection 3 (detection level of voltage detection 0 and voltage detection 1 selectable)</li> </ul>
I/O Ports	Programmable I/O ports	R8C/L35C Group	<ul style="list-style-type: none"> <li>• CMOS I/O ports: 41, selectable pull-up resistor</li> <li>• High current drive ports: 5</li> </ul>
		R8C/L36C Group	<ul style="list-style-type: none"> <li>• CMOS I/O ports: 52, selectable pull-up resistor</li> <li>• High current drive ports: 8</li> </ul>
		R8C/L38C Group	<ul style="list-style-type: none"> <li>• CMOS I/O ports: 68, selectable pull-up resistor</li> <li>• High current drive ports: 8</li> </ul>
		R8C/L3AC Group	<ul style="list-style-type: none"> <li>• CMOS I/O ports: 88, selectable pull-up resistor</li> <li>• High current drive ports: 16</li> </ul>
Clock	Clock generation circuits		4 circuits: XIN clock oscillation circuit XCIN clock oscillation circuit (32 kHz) High-speed on-chip oscillator (with frequency adjustment function) Low-speed on-chip oscillator <ul style="list-style-type: none"> <li>• Oscillation stop detection:               <ul style="list-style-type: none"> <li>XIN clock oscillation stop detection function</li> </ul> </li> <li>• Frequency divider circuit:               <ul style="list-style-type: none"> <li>Division ratio selectable from 1, 2, 4, 8, and 16</li> </ul> </li> <li>• Low-power-consumption modes:               <ul style="list-style-type: none"> <li>Standard operating mode (high-speed clock, low-speed clock, high-speed on-chip oscillator, low-speed on-chip oscillator), wait mode, stop mode, power-off mode</li> </ul> </li> </ul>
			Real-time clock (timer RE)
Interrupts	R8C/L35C Group		<ul style="list-style-type: none"> <li>• Number of interrupt vectors: 69</li> <li>• External Interrupt: 9 (<math>\overline{INT} \times 5</math>, key input <math>\times 4</math>)</li> <li>• Priority levels: 7 levels</li> </ul>
	R8C/L36C Group		<ul style="list-style-type: none"> <li>• Number of interrupt vectors: 69</li> <li>• External Interrupt: 12 (<math>\overline{INT} \times 8</math>, key input <math>\times 4</math>)</li> <li>• Priority levels: 7 levels</li> </ul>
	R8C/L38C Group		<ul style="list-style-type: none"> <li>• Number of interrupt vectors: 69</li> <li>• External Interrupt: 16 (<math>\overline{INT} \times 8</math>, key input <math>\times 8</math>)</li> <li>• Priority levels: 7 levels</li> </ul>
	R8C/L3AC Group		<ul style="list-style-type: none"> <li>• Number of interrupt vectors: 69</li> <li>• External Interrupt: 16 (<math>\overline{INT} \times 8</math>, key input <math>\times 8</math>)</li> <li>• Priority levels: 7 levels</li> </ul>
Watchdog Timer			<ul style="list-style-type: none"> <li>• 14 bits <math>\times</math> 1 (with prescaler)</li> <li>• Selectable reset start function</li> <li>• Selectable low-speed on-chip oscillator for watchdog timer</li> </ul>
DTC (Data Transfer Controller)			<ul style="list-style-type: none"> <li>• 1 channel</li> <li>• Activation sources: 38</li> <li>• Transfer modes: 2 (normal mode, repeat mode)</li> </ul>

**Table 1.5 Specifications (2)**

Item	Function	Specification	
Timer	Timer RA	8 bits × 1 (with 8-bit prescaler) Timer mode (period timer), pulse output mode (output level inverted every period), event counter mode, pulse width measurement mode, pulse period measurement mode	
	Timer RB	8 bits × 1 (with 8-bit prescaler) Timer mode (period timer), programmable waveform generation mode (PWM output), programmable one-shot generation mode, programmable wait one-shot generation mode	
	Timer RC	16 bits × 1 (with 4 capture/compare registers) Timer mode (input capture function, output compare function), PWM mode (output: 3 pins), PWM2 mode (PWM output: 1 pin)	
	Timer RD	16 bits × 2 (with 4 capture/compare registers) Timer mode (input capture function, output compare function), PWM mode (output: 6 pins), reset synchronous PWM mode (three-phase waveform output: 6 pins, sawtooth wave modulation), complementary PWM mode (three-phase waveform output: 6 pins, triangular wave modulation), PWM3 mode (PWM output with fixed period: 2 pins)	
	Timer RE	8 bits × 1 Real-time clock mode (counting of seconds, minutes, hours, days of week), output compare mode	
	Timer RG	16 bits × 1 Phase-counting mode, timer mode (output compare function, input capture function), PWM mode (output: 1 pin)	
Serial Interface	UART0, UART1	Clock synchronous serial I/O/UART × 2 channels	
	UART2	Clock synchronous serial I/O/UART, I <sup>2</sup> C mode (I <sup>2</sup> C-bus), multiprocessor communication function	
Synchronous Serial Communication Unit (SSU)		1 (shared with I <sup>2</sup> C-bus)	
I <sup>2</sup> C bus		1 (shared with SSU)	
LIN Module		Hardware LIN: 1 channel (timer RA, UART0 used)	
A/D Converter	R8C/L35C Group	10-bit resolution × 10 channels, including sample and hold function, with sweep mode	
	R8C/L36C Group	10-bit resolution × 10 channels, including sample and hold function, with sweep mode	
	R8C/L38C Group	10-bit resolution × 16 channels, including sample and hold function, with sweep mode	
	R8C/L3AC Group	10-bit resolution × 20 channels, including sample and hold function, with sweep mode	
D/A Converter		8-bit resolution × 2 circuits	
Comparator B		2 circuits	
LCD Drive Control Circuit	R8C/L35C Group	Common output: Max. 4 pins Segment output: Max. 24 pins	Bias: 1/2, 1/3 Duty: static, 1/2, 1/3, 1/4
	R8C/L36C Group	Common output: Max. 8 pins Segment output: Max. 32 pins <sup>(1)</sup>	
	R8C/L38C Group	Common output: Max. 8 pins Segment output: Max. 48 pins <sup>(1)</sup>	Bias: 1/2, 1/3, 1/4 Duty: static, 1/2, 1/3, 1/4, 1/8
	R8C/L3AC Group	Common output: Max. 8 pins Segment output: Max. 56 pins <sup>(1)</sup>	
			Voltage multiplier and dedicated regulator integrated

Note:

1. This applies when four pins are selected for common output.

**Table 1.6 Specifications (3)**

Item	Specification
Flash Memory	<ul style="list-style-type: none"> <li>• Programming and erasure voltage: VCC = 2.7 to 5.5 V</li> <li>• Programming and erasure endurance: 10,000 times (data flash) 1,000 times (program ROM)</li> <li>• Program security: ROM code protect, ID code check</li> <li>• On-chip debug function</li> <li>• On-board flash rewrite function</li> <li>• Background operation (BGO) function</li> </ul>
Operating Frequency/ Supply Voltage	f(XIN) = 20 MHz (VCC = 2.7 to 5.5 V) f(XIN) = 5 MHz (VCC = 1.8 to 5.5 V)
Current Consumption	Typ. 7 mA (VCC = 5.0 V, f(XIN) = 20 MHz) Typ. 3.6 mA (VCC = 3.0 V, f(XIN) = 10 MHz) Typ. 3.5 $\mu$ A (VCC = 3.0 V, wait mode (f(XCIN) = 32 kHz)) Typ. 2 $\mu$ A (VCC = 3.0 V, stop mode) Typ. 0.02 $\mu$ A (VCC = 3.0 V, power-off mode)
Operating Ambient Temperature	-20 to 85°C (N version) -40 to 85°C (D version) <sup>(1)</sup>

Note:

1. Specify the D version if D version functions are to be used.

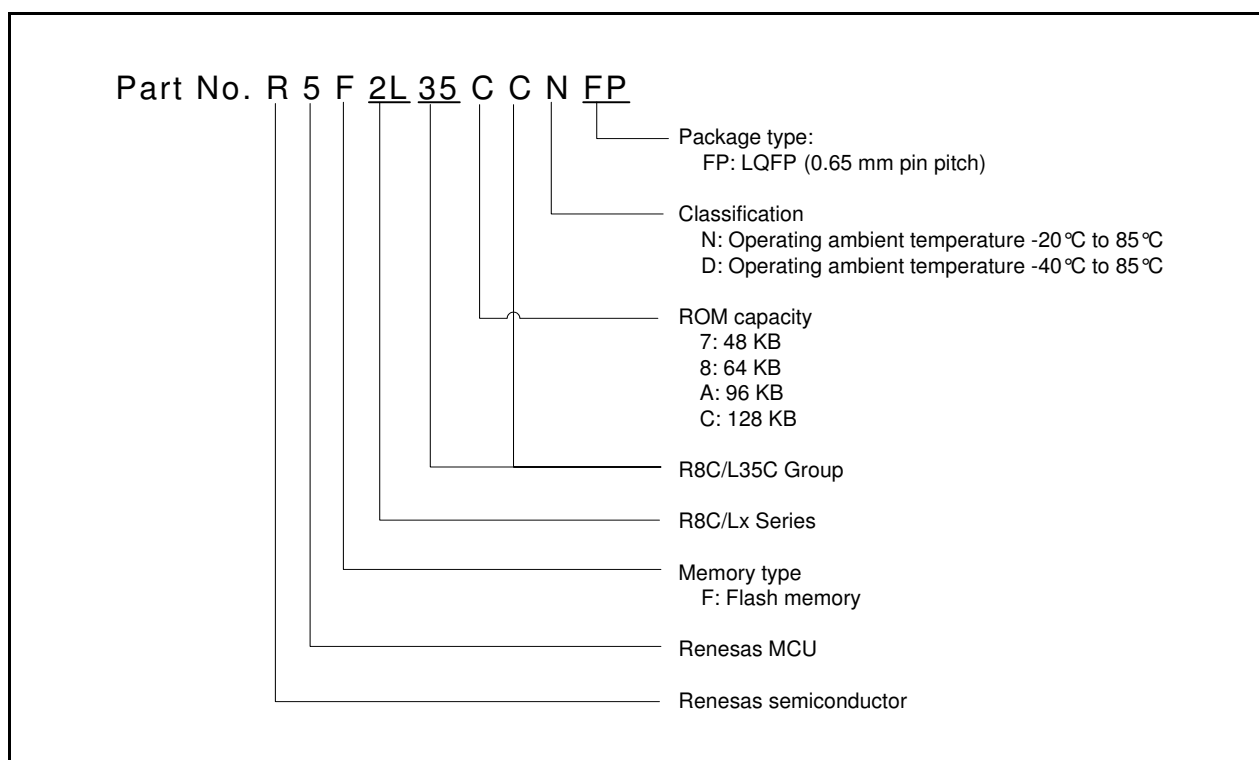
## 1.2 Product Lists

Tables 1.7 to 1.10 list Product List for Each Group. Figures 1.1 to 1.4 show the Correspondence of Part No., with Memory Size and Package for Each Group.

**Table 1.7 Product List for R8C/L35C Group**

**Current of Apr 2011**

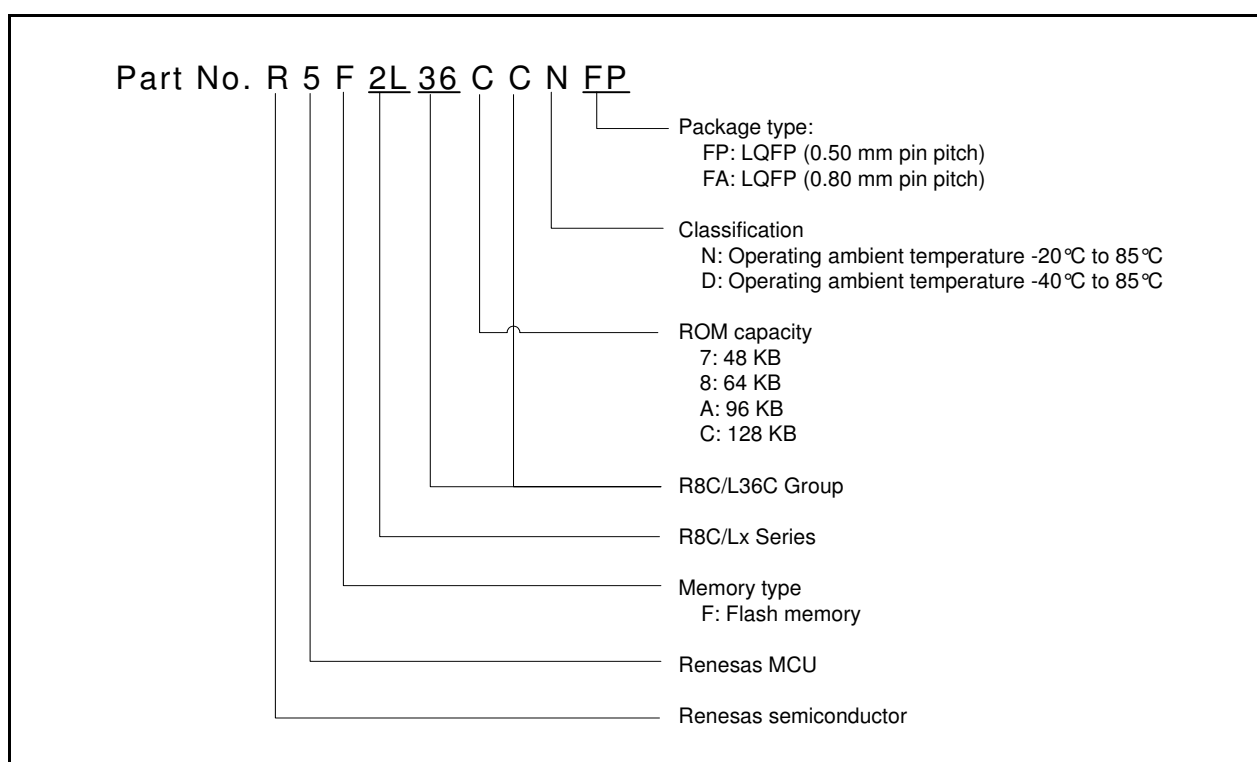
Part No.	Internal ROM Capacity		Internal RAM Capacity	Package Type	Remarks
	Program ROM	Data Flash			
R5F2L357CNFP	48 Kbytes	1 Kbyte × 4	6 Kbytes	PLQP0052JA-A	N Version
R5F2L358CNFP	64 Kbytes	1 Kbyte × 4	8 Kbytes	PLQP0052JA-A	
R5F2L35ACNFP	96 Kbytes	1 Kbyte × 4	10 Kbytes	PLQP0052JA-A	
R5F2L35CCNFP	128 Kbytes	1 Kbyte × 4	10 Kbytes	PLQP0052JA-A	
R5F2L357CDFP	48 Kbytes	1 Kbyte × 4	6 Kbytes	PLQP0052JA-A	D Version
R5F2L358CDFP	64 Kbytes	1 Kbyte × 4	8 Kbytes	PLQP0052JA-A	
R5F2L35ACDFP	96 Kbytes	1 Kbyte × 4	10 Kbytes	PLQP0052JA-A	
R5F2L35CCDFP	128 Kbytes	1 Kbyte × 4	10 Kbytes	PLQP0052JA-A	



**Figure 1.1 Correspondence of Part No., with Memory Size and Package of R8C/L35C Group**

**Table 1.8 Product List for R8C/L36C Group****Current of Apr 2011**

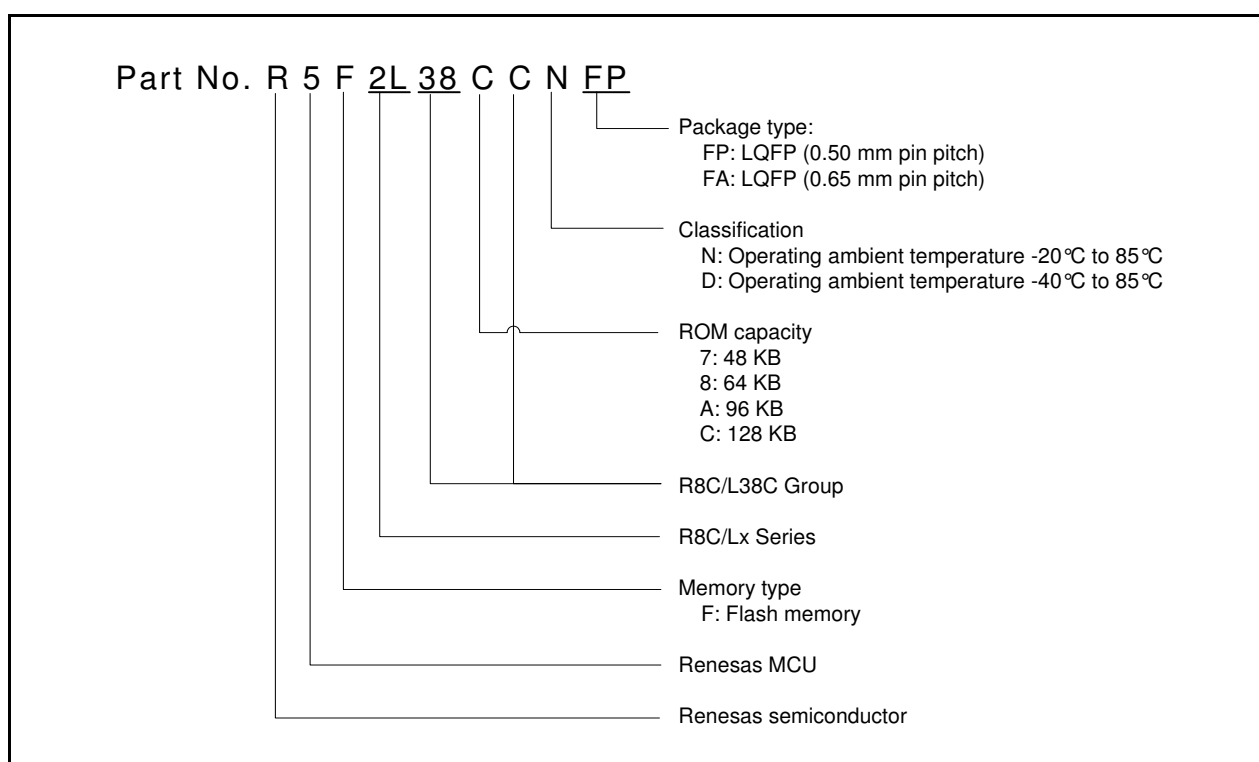
Part No.	Internal ROM Capacity		Internal RAM Capacity	Package Type	Remarks
	Program ROM	Data Flash			
R5F2L367CNFP	48 Kbytes	1 Kbyte × 4	6 Kbytes	PLQP0064KB-A	N Version
R5F2L367CNFA	48 Kbytes	1 Kbyte × 4	6 Kbytes	PLQP0064GA-A	
R5F2L368CNFP	64 Kbytes	1 Kbyte × 4	8 Kbytes	PLQP0064KB-A	
R5F2L368CNFA	64 Kbytes	1 Kbyte × 4	8 Kbytes	PLQP0064GA-A	
R5F2L36ACNFP	96 Kbytes	1 Kbyte × 4	10 Kbytes	PLQP0064KB-A	
R5F2L36ACNFA	96 Kbytes	1 Kbyte × 4	10 Kbytes	PLQP0064GA-A	
R5F2L36CCNFP	128 Kbytes	1 Kbyte × 4	10 Kbytes	PLQP0064KB-A	
R5F2L36CCNFA	128 Kbytes	1 Kbyte × 4	10 Kbytes	PLQP0064GA-A	
R5F2L367CDFP	48 Kbytes	1 Kbyte × 4	6 Kbytes	PLQP0064KB-A	D Version
R5F2L367CDFA	48 Kbytes	1 Kbyte × 4	6 Kbytes	PLQP0064GA-A	
R5F2L368CDFP	64 Kbytes	1 Kbyte × 4	8 Kbytes	PLQP0064KB-A	
R5F2L368CDFA	64 Kbytes	1 Kbyte × 4	8 Kbytes	PLQP0064GA-A	
R5F2L36ACDFP	96 Kbytes	1 Kbyte × 4	10 Kbytes	PLQP0064KB-A	
R5F2L36ACDFA	96 Kbytes	1 Kbyte × 4	10 Kbytes	PLQP0064GA-A	
R5F2L36CCDFP	128 Kbytes	1 Kbyte × 4	10 Kbytes	PLQP0064KB-A	
R5F2L36CCDFA	128 Kbytes	1 Kbyte × 4	10 Kbytes	PLQP0064GA-A	

**Figure 1.2 Correspondence of Part No., with Memory Size and Package of R8C/L36C Group**



**Table 1.9 Product List for R8C/L38C Group** **Current of Apr 2011**

Part No.	Internal ROM Capacity		Internal RAM Capacity	Package Type	Remarks
	Program ROM	Data Flash			
R5F2L387CNFP	48 Kbytes	1 Kbyte × 4	6 Kbytes	PLQP0080KB-A	N Version
R5F2L387CNFA	48 Kbytes	1 Kbyte × 4	6 Kbytes	PLQP0080JA-A	
R5F2L388CNFP	64 Kbytes	1 Kbyte × 4	8 Kbytes	PLQP0080KB-A	
R5F2L388CNFA	64 Kbytes	1 Kbyte × 4	8 Kbytes	PLQP0080JA-A	
R5F2L38ACNFP	96 Kbytes	1 Kbyte × 4	10 Kbytes	PLQP0080KB-A	
R5F2L38ACNFA	96 Kbytes	1 Kbyte × 4	10 Kbytes	PLQP0080JA-A	
R5F2L38CCNFP	128 Kbytes	1 Kbyte × 4	10 Kbytes	PLQP0080KB-A	
R5F2L38CCNFA	128 Kbytes	1 Kbyte × 4	10 Kbytes	PLQP0080JA-A	
R5F2L387CDFP	48 Kbytes	1 Kbyte × 4	6 Kbytes	PLQP0080KB-A	D Version
R5F2L387CDFA	48 Kbytes	1 Kbyte × 4	6 Kbytes	PLQP0080JA-A	
R5F2L388CDFP	64 Kbytes	1 Kbyte × 4	8 Kbytes	PLQP0080KB-A	
R5F2L388CDFA	64 Kbytes	1 Kbyte × 4	8 Kbytes	PLQP0080JA-A	
R5F2L38ACDFP	96 Kbytes	1 Kbyte × 4	10 Kbytes	PLQP0080KB-A	
R5F2L38ACDFA	96 Kbytes	1 Kbyte × 4	10 Kbytes	PLQP0080JA-A	
R5F2L38CCDFP	128 Kbytes	1 Kbyte × 4	10 Kbytes	PLQP0080KB-A	
R5F2L38CCDFA	128 Kbytes	1 Kbyte × 4	10 Kbytes	PLQP0080JA-A	

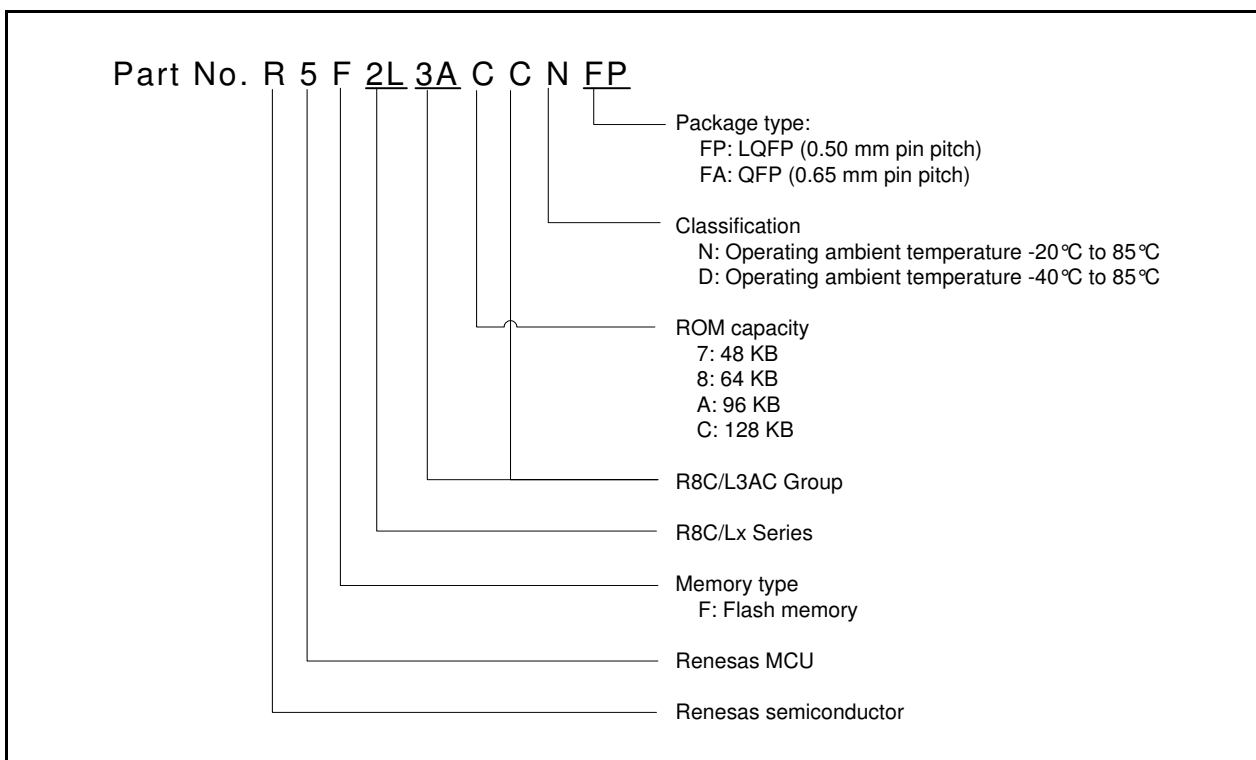


**Figure 1.3 Correspondence of Part No., with Memory Size and Package of R8C/L38C Group**

**Table 1.10 Product List for R8C/L3AC Group**

**Current of Apr 2011**

Part No.	Internal ROM Capacity		Internal RAM Capacity	Package Type	Remarks
	Program ROM	Data Flash			
R5F2L3A7CNFP	48 Kbytes	1 Kbyte × 4	6 Kbytes	PLQP0100KB-A	N Version
R5F2L3A7CNFA	48 Kbytes	1 Kbyte × 4	6 Kbytes	PRQP0100JD-B	
R5F2L3A8CNFP	64 Kbytes	1 Kbyte × 4	8 Kbytes	PLQP0100KB-A	
R5F2L3A8CNFA	64 Kbytes	1 Kbyte × 4	8 Kbytes	PRQP0100JD-B	
R5F2L3AACNFP	96 Kbytes	1 Kbyte × 4	10 Kbytes	PLQP0100KB-A	
R5F2L3AACNFA	96 Kbytes	1 Kbyte × 4	10 Kbytes	PRQP0100JD-B	
R5F2L3ACCNFP	128 Kbytes	1 Kbyte × 4	10 Kbytes	PLQP0100KB-A	
R5F2L3ACCNFA	128 Kbytes	1 Kbyte × 4	10 Kbytes	PRQP0100JD-B	
R5F2L3A7CDFP	48 Kbytes	1 Kbyte × 4	6 Kbytes	PLQP0100KB-A	D Version
R5F2L3A7CDFA	48 Kbytes	1 Kbyte × 4	6 Kbytes	PRQP0100JD-B	
R5F2L3A8CDFP	64 Kbytes	1 Kbyte × 4	8 Kbytes	PLQP0100KB-A	
R5F2L3A8CDFA	64 Kbytes	1 Kbyte × 4	8 Kbytes	PRQP0100JD-B	
R5F2L3AACDFP	96 Kbytes	1 Kbyte × 4	10 Kbytes	PLQP0100KB-A	
R5F2L3AACDFA	96 Kbytes	1 Kbyte × 4	10 Kbytes	PRQP0100JD-B	
R5F2L3ACCDFP	128 Kbytes	1 Kbyte × 4	10 Kbytes	PLQP0100KB-A	
R5F2L3ACCDFA	128 Kbytes	1 Kbyte × 4	10 Kbytes	PRQP0100JD-B	



**Figure 1.4 Correspondence of Part No., with Memory Size and Package of R8C/L3AC Group**

### 1.3 Block Diagrams

Figure 1.5 shows a Block Diagram of R8C/L35C Group. Figure 1.6 shows a Block Diagram of R8C/L36C Group. Figure 1.7 shows a Block Diagram of R8C/L38C Group. Figure 1.8 shows a Block Diagram of R8C/L3AC Group.

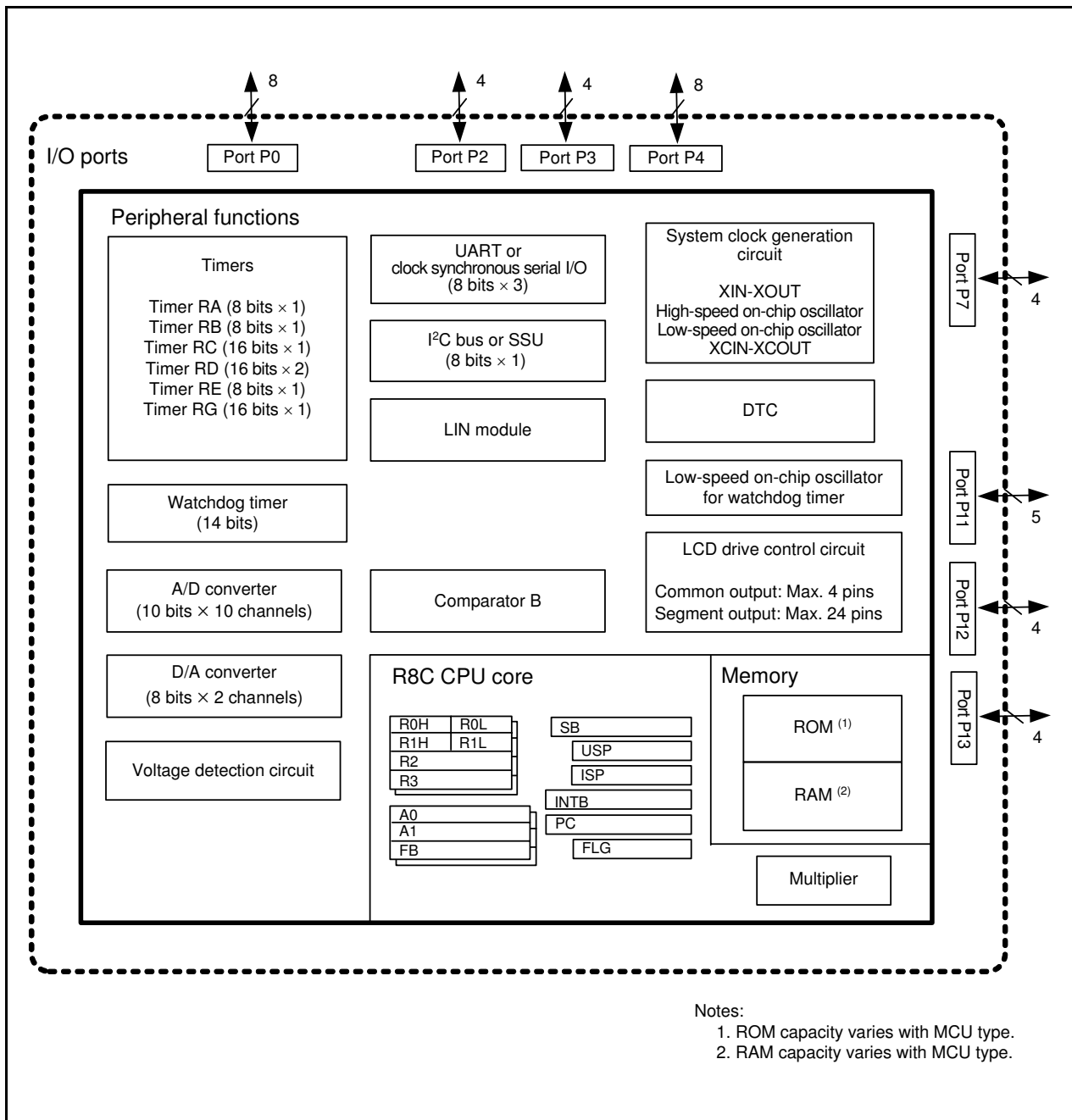


Figure 1.5 Block Diagram of R8C/L35C Group

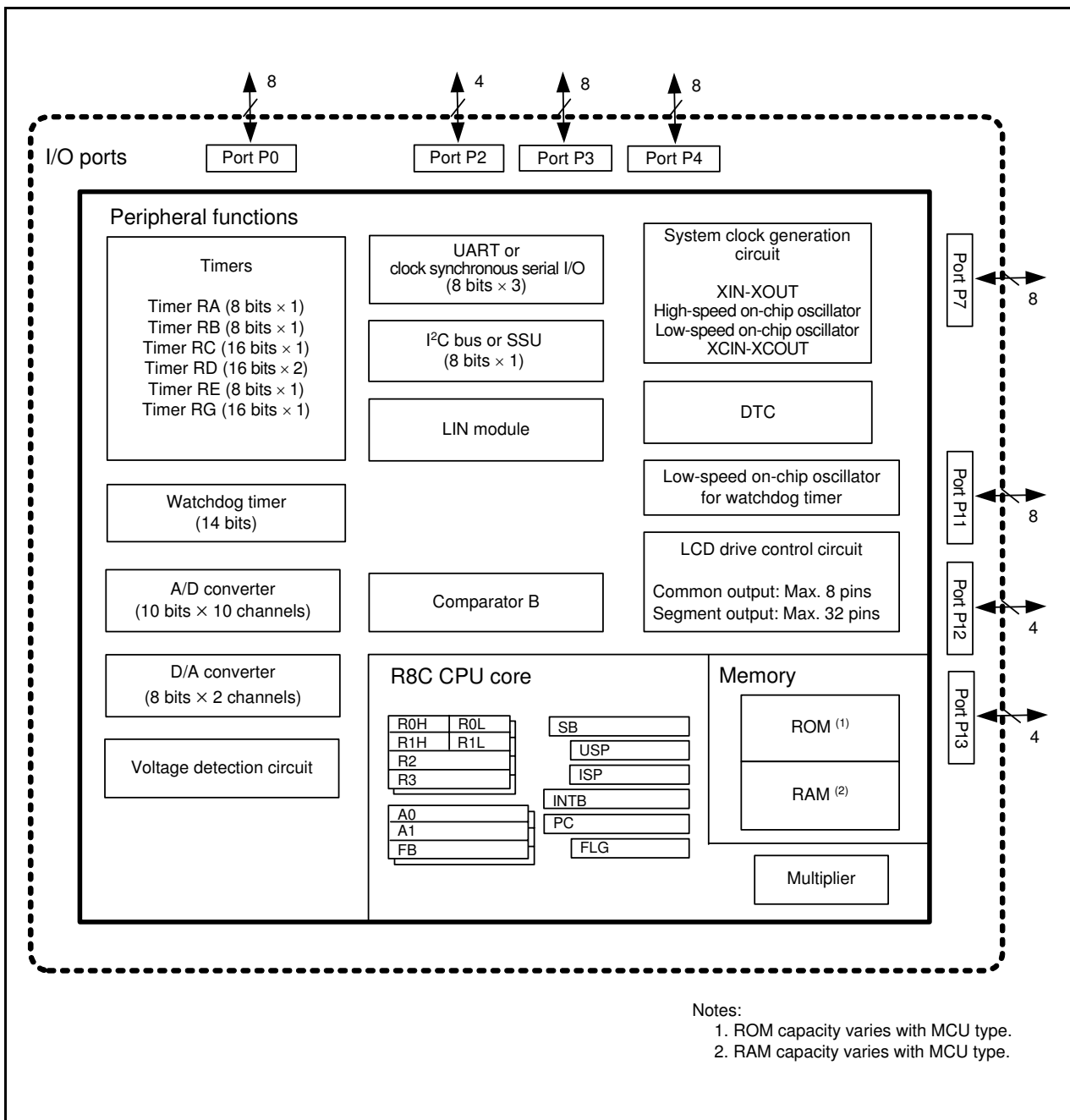


Figure 1.6 Block Diagram of R8C/L36C Group

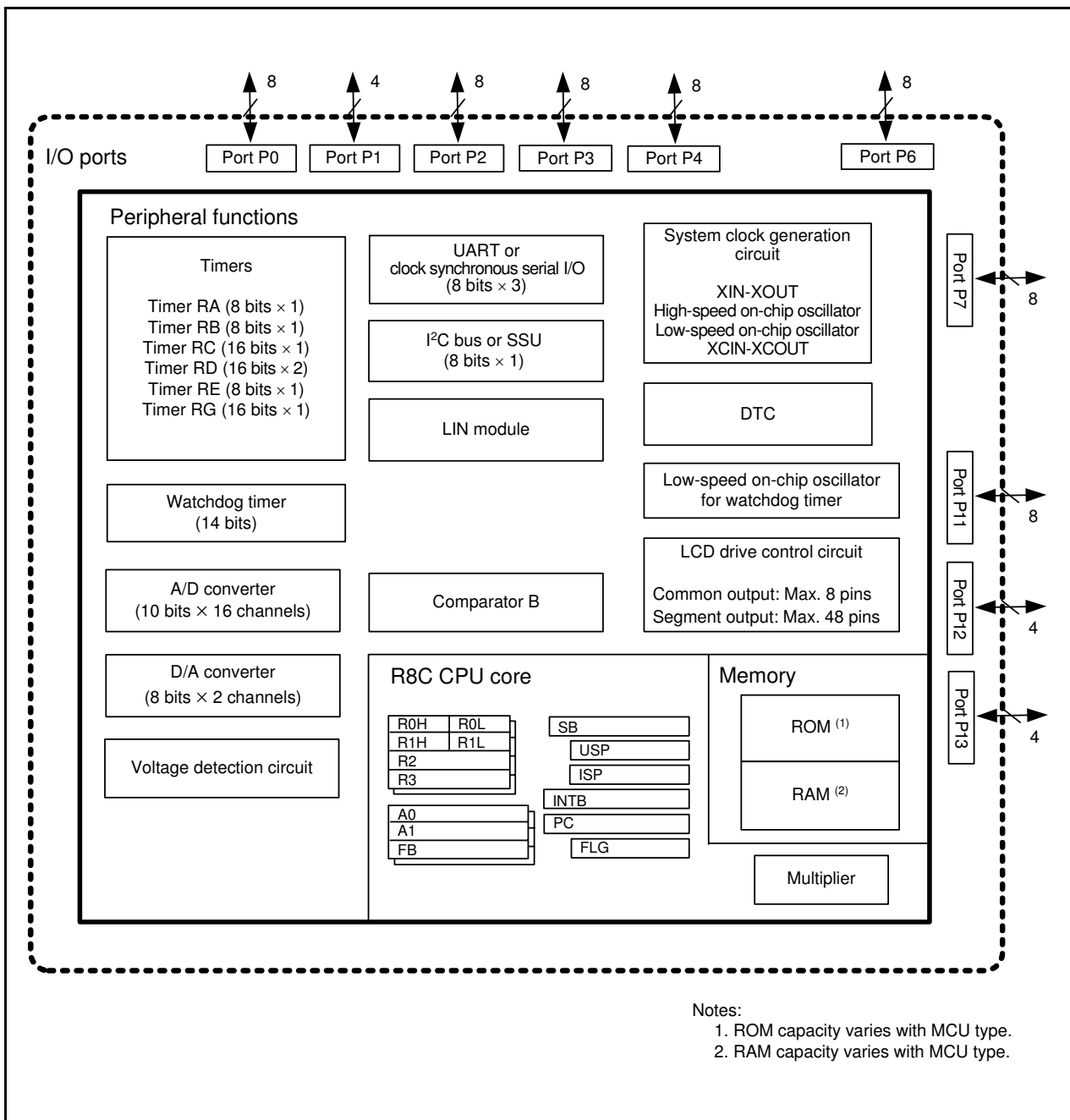


Figure 1.7 Block Diagram of R8C/L38C Group

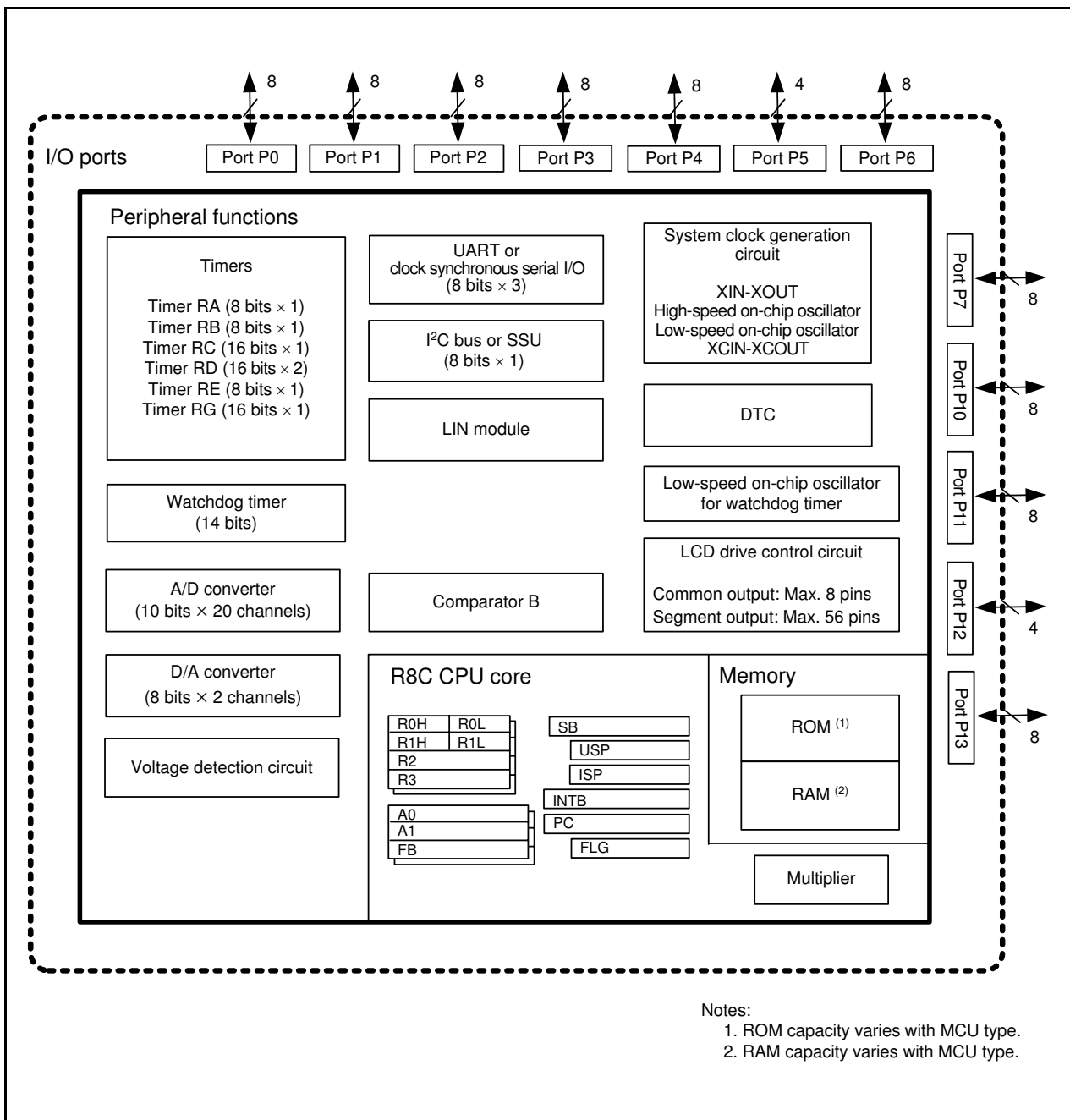
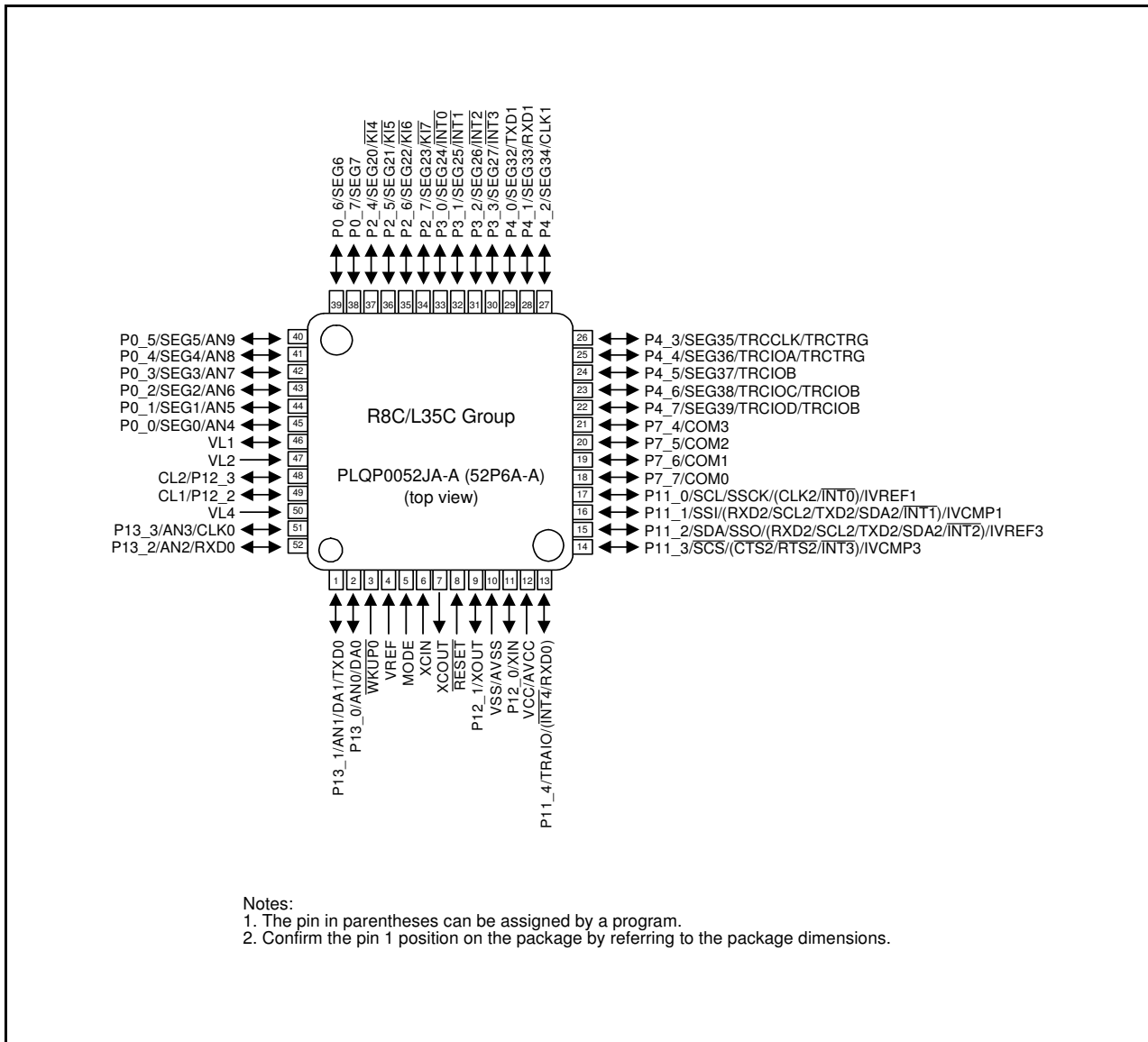


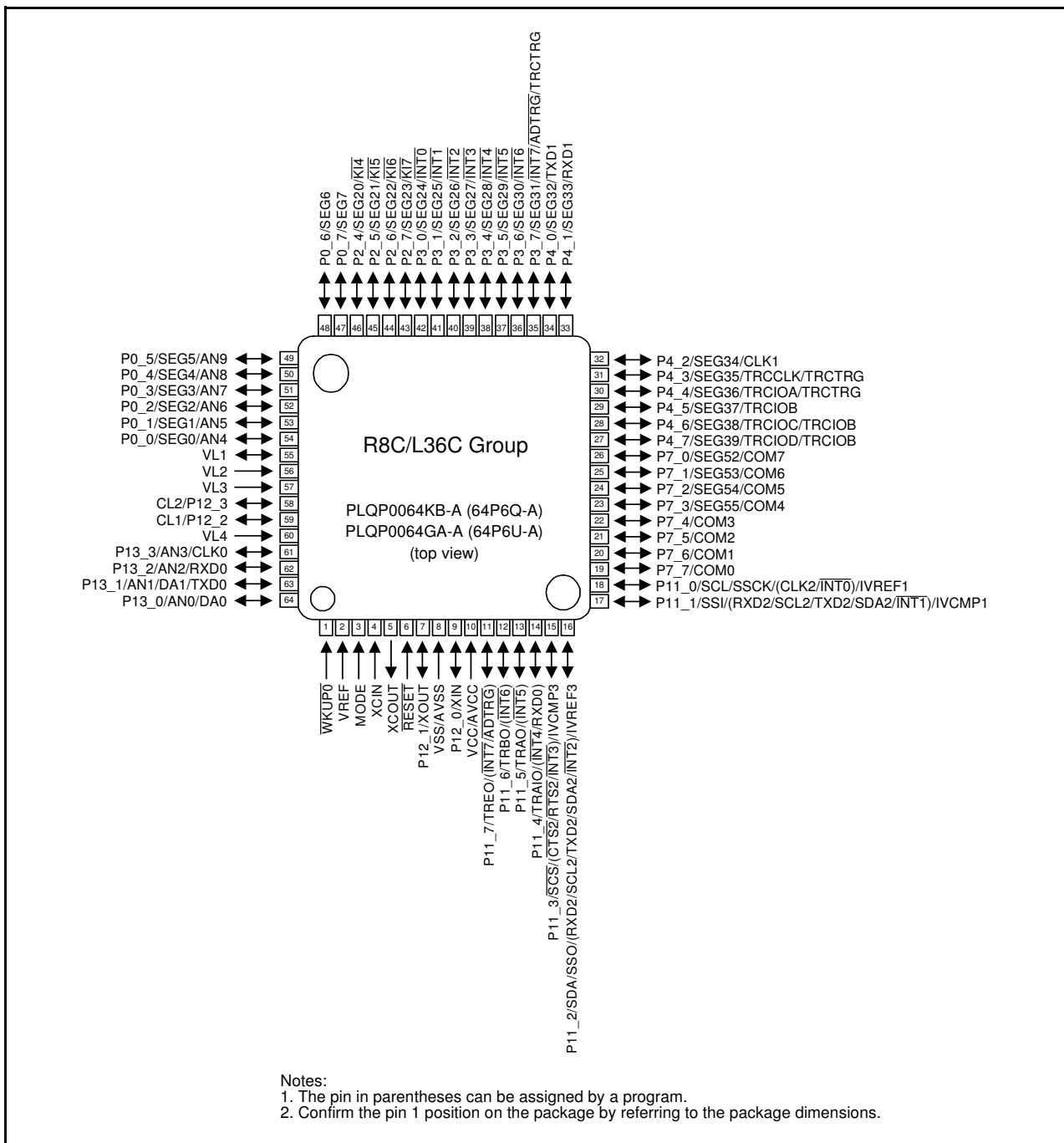
Figure 1.8 Block Diagram of R8C/L3AC Group

### 1.4 Pin Assignments

Figures 1.9 to 1.13 show Pin Assignments (Top View). Tables 1.11 to 1.13 list the Pin Name Information by Pin Number.



**Figure 1.9 Pin Assignment (Top View) of PLQP0052JA-A Package**



**Figure 1.10 Pin Assignment (Top View) of PLQP0064KB-A and PLQP0064GA-A Packages**



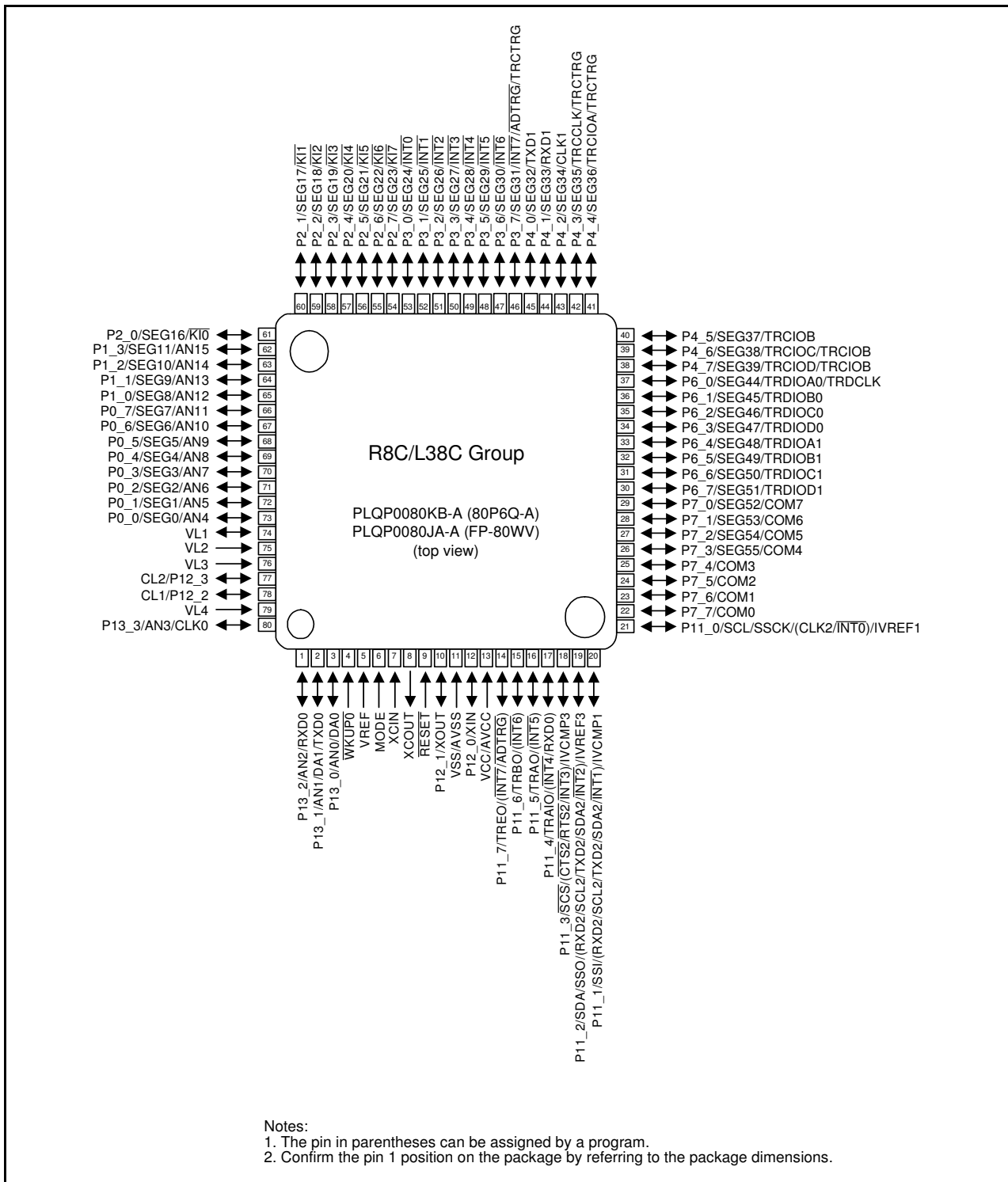


Figure 1.11 Pin Assignment (Top View) of PLQP0080KB-A and PLQP0080JA-A Packages

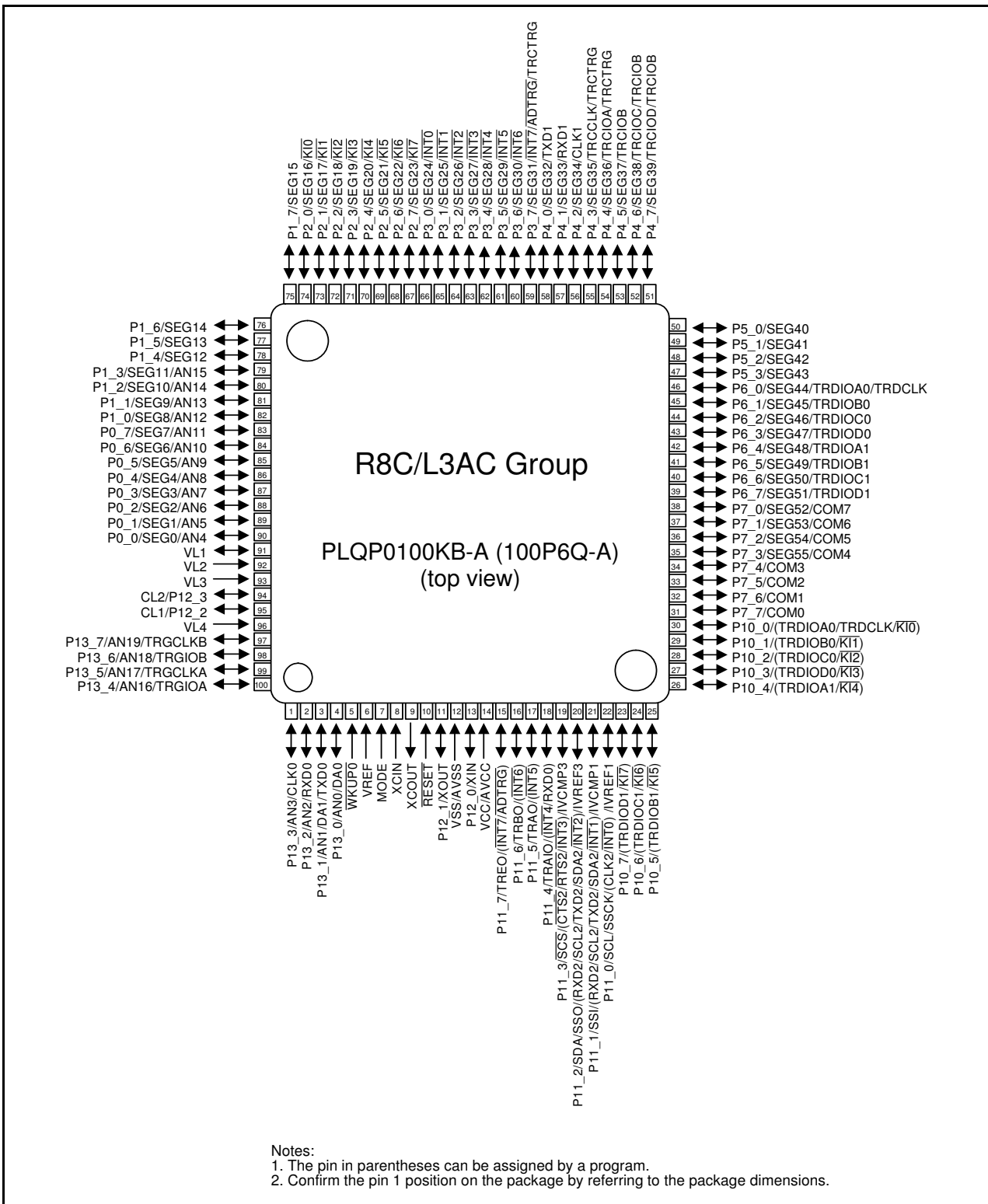
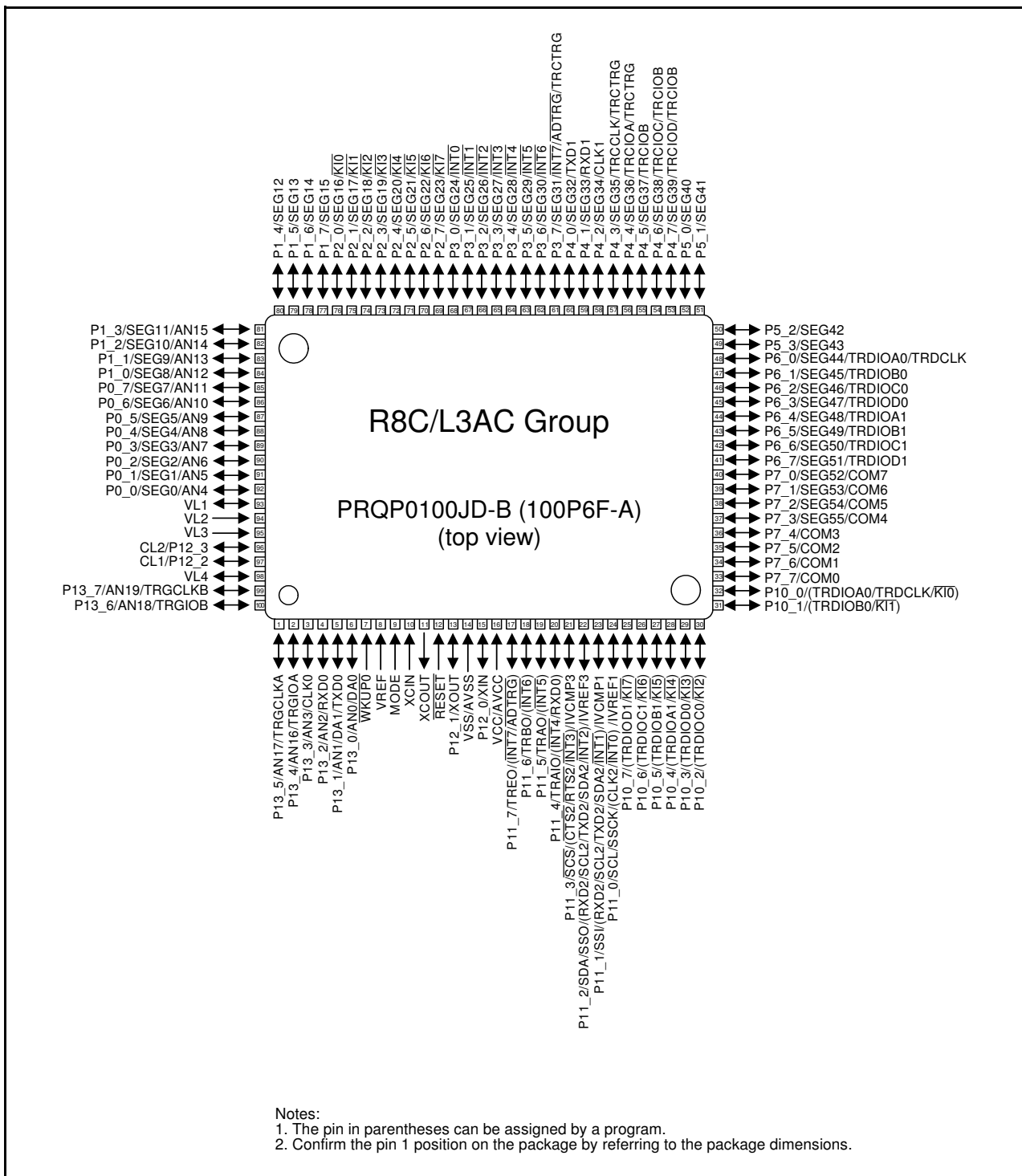


Figure 1.12 Pin Assignment (Top View) of PLQP0100KB-A Package



**Figure 1.13 Pin Assignment (Top View) of PRQP0100JD-B Package**

**Table 1.11 Pin Name Information by Pin Number (1)**

Pin Number				Control Pin	Port	I/O Pin Functions for Peripheral Modules						
L3AC (Note 2)	L38C	L36C	L35C			Interrupt	Timer	Serial Interface	SSU	I <sup>2</sup> C bus	A/D Converter, D/A Converter, Comparator B	LCD drive control circuit
1 [3]	80	61	51		P13_3			CLK0			AN3	
2 [4]	1	62	52		P13_2			RXD0			AN2	
3 [5]	2	63	1		P13_1			TXD0			AN1/DA1	
4 [6]	3	64	2		P13_0						AN0/DA0	
5 [7]	4	1	3	$\overline{WKUP0}$								
6 [8]	5	2	4	VREF								
7 [9]	6	3	5	MODE								
8 [10]	7	4	6	XCIN								
9 [11]	8	5	7	XCOUT								
10 [12]	9	6	8	$\overline{RESET}$								
11 [13]	10	7	9	XOUT	P12_1							
12 [14]	11	8	10	VSS/AVSS								
13 [15]	12	9	11	XIN	P12_0							
14 [16]	13	10	12	VCC/AVCC								
15 [17]	14	11			P11_7	$(\overline{INT7})$	TREO				$(\overline{ADTRG})$	
16 [18]	15	12			P11_6	$(\overline{INT6})$	TRBO					
17 [19]	16	13			P11_5	$(\overline{INT5})$	TRAO					
18 [20]	17	14	13		P11_4	$(\overline{INT4})$	TRAIO	(RXD0)				
19 [21]	18	15	14		P11_3	$(\overline{INT3})$		$(\overline{CTS2/RTS2})$	SCS		IVCMP3	
20 [22]	19	16	15		P11_2	$(\overline{INT2})$		(RXD2/SCL2/ TXD2/SDA2)	SSO	SDA	IVREF3	
21 [23]	20	17	16		P11_1	$(\overline{INT1})$		(RXD2/SCL2/ TXD2/SDA2)	SSI		IVCMP1	
22 [24]	21	18	17		P11_0	$(\overline{INT0})$		(CLK2)	SSCK	SCL	IVREF1	
23 [25]					P10_7	$(\overline{KI7})$	(TRDIOD1)					
24 [26]					P10_6	$(\overline{KI6})$	(TRDIOC1)					
25 [27]					P10_5	$(\overline{KI5})$	(TRDIOB1)					
26 [28]					P10_4	$(\overline{KI4})$	(TRDIOA1)					
27 [29]					P10_3	$(\overline{KI3})$	(TRDIOD0)					
28 [30]					P10_2	$(\overline{KI2})$	(TRDIOC0)					
29 [31]					P10_1	$(\overline{KI1})$	(TRDIOB0)					
30 [32]					P10_0	$(\overline{KI0})$	(TRDIOA0/ TRDCLK)					
31 [33]	22	19	18		P7_7							COM0
32 [34]	23	20	19		P7_6							COM1
33 [35]	24	21	20		P7_5							COM2
34 [36]	25	22	21		P7_4							COM3
35 [37]	26	23			P7_3							SEG55/ COM4
36 [38]	27	24			P7_2							SEG54/ COM5
37 [39]	28	25			P7_1							SEG53/ COM6
38 [40]	29	26			P7_0							SEG52/ COM7
39 [41]	30				P6_7		TRDIOD1					SEG51

## Notes:

1. The pin in parentheses can be assigned by a program.
2. The number in brackets indicates the pin number for the 100P6F package.

**Table 1.12 Pin Name Information by Pin Number (2)**

Pin Number				Control Pin	Port	I/O Pin Functions for Peripheral Modules						
L3AC (Note 2)	L38C	L36C	L35C			Interrupt	Timer	Serial Interface	SSU	I <sup>2</sup> C bus	A/D Converter, D/A Converter, Comparator B	LCD drive control circuit
40 [42]	31				P6_6		TRDIOC1					SEG50
41 [43]	32				P6_5		TRDIOB1					SEG49
42 [44]	33				P6_4		TRDIOA1					SEG48
43 [45]	34				P6_3		TRDIOD0					SEG47
44 [46]	35				P6_2		TRDIOC0					SEG46
45 [47]	36				P6_1		TRDIOB0					SEG45
46 [48]	37				P6_0		TRDIOA0/ TRDCLK					SEG44
47 [49]					P5_3							SEG43
48 [50]					P5_2							SEG42
49 [51]					P5_1							SEG41
50 [52]					P5_0							SEG40
51 [53]	38	27	22		P4_7		TRCIOD/ TRCIOB					SEG39
52 [54]	39	28	23		P4_6		TRCIOA/ TRCIOB					SEG38
53 [55]	40	29	24		P4_5		TRCIOB					SEG37
54 [56]	41	30	25		P4_4		TRCIOA/ TRCTR					SEG36
55 [57]	42	31	26		P4_3		TRCCLK/ TRCTR					SEG35
56 [58]	43	32	27		P4_2			CLK1				SEG34
57 [59]	44	33	28		P4_1			RXD1				SEG33
58 [60]	45	34	29		P4_0			TXD1				SEG32
59 [61]	46	35			P3_7	$\overline{\text{INT7}}$	TRCTR				$\overline{\text{ADTRG}}$	SEG31
60 [62]	47	36			P3_6	$\overline{\text{INT6}}$						SEG30
61 [63]	48	37			P3_5	$\overline{\text{INT5}}$						SEG29
62 [64]	49	38			P3_4	$\overline{\text{INT4}}$						SEG28
63 [65]	50	39	30		P3_3	$\overline{\text{INT3}}$						SEG27
64 [66]	51	40	31		P3_2	$\overline{\text{INT2}}$						SEG26
65 [67]	52	41	32		P3_1	$\overline{\text{INT1}}$						SEG25
66 [68]	53	42	33		P3_0	$\overline{\text{INT0}}$						SEG24
67 [69]	54	43	34		P2_7	$\overline{\text{KI7}}$						SEG23
68 [70]	55	44	35		P2_6	$\overline{\text{KI6}}$						SEG22
69 [71]	56	45	36		P2_5	$\overline{\text{KI5}}$						SEG21
70 [72]	57	46	37		P2_4	$\overline{\text{KI4}}$						SEG20
71 [73]	58				P2_3	$\overline{\text{KI3}}$						SEG19
72 [74]	59				P2_2	$\overline{\text{KI2}}$						SEG18
73 [75]	60				P2_1	$\overline{\text{KI1}}$						SEG17
74 [76]	61				P2_0	$\overline{\text{KI0}}$						SEG16
75 [77]					P1_7							SEG15
76 [78]					P1_6							SEG14
77 [79]					P1_5							SEG13
78 [80]					P1_4							SEG12
79 [81]	62				P1_3					AN15		SEG11
80 [82]	63				P1_2					AN14		SEG10
81 [83]	64				P1_1					AN13		SEG9
82 [84]	65				P1_0					AN12		SEG8
83 [85]	66	47	38		P0_7					AN11 <sup>(3)</sup>		SEG7
84 [86]	67	48	39		P0_6					AN10 <sup>(3)</sup>		SEG6

## Notes:

1. The pin in parentheses can be assigned by a program.
2. The number in brackets indicates the pin number for the 100P6F package.
3. Pins AN10 and AN11 are not available in the R8C/L35C, and R8C/L36C Groups.

**Table 1.13 Pin Name Information by Pin Number (3)**

Pin Number				Control Pin	Port	I/O Pin Functions for Peripheral Modules						
L3AC (Note 2)	L38C	L36C	L35C			Interrupt	Timer	Serial Interface	SSU	I <sup>2</sup> C bus	A/D Converter, D/A Converter, Comparator B	LCD drive control circuit
85 [87]	68	49	40		P0_5							
86 [88]	69	50	41		P0_4					AN9	SEG5	
87 [89]	70	51	42		P0_3					AN8	SEG4	
88 [90]	71	52	43		P0_2					AN7	SEG3	
89 [91]	72	53	44		P0_1					AN6	SEG2	
90 [92]	73	54	45		P0_0					AN5	SEG1	
91 [93]	74	55	46							AN4	SEG0	
92 [94]	75	56	47								VL1	
93 [95]	76	57									VL2	
94 [96]	77	58	48		P12_3						VL3	
95 [97]	78	59	49		P12_2						CL2	
96 [98]	79	60	50								CL1	
97 [99]					P13_7		TRGCLKB				VL4	
98 [100]					P13_6		TRGI0B			AN19		
99 [1]					P13_5		TRGCLKA			AN18		
100 [2]					P13_4		TRGIOA			AN17		
										AN16		

## Notes:

1. The pin in parentheses can be assigned by a program.
2. The number in brackets indicates the pin number for the 100P6F package.

## 1.5 Pin Functions

Tables 1.14 and 1.15 list Pin Functions for R8C/L3AC Group.

**Table 1.14 Pin Functions for R8C/L3AC Group (1)**

Item	Pin Name	I/O Type	Description
Power supply input	VCC, VSS	–	Apply 1.8 V to 5.5 V to the VCC pin. Apply 0 V to the VSS pin.
Analog power supply input	AVCC, AVSS	–	Power supply for the A/D converter. Connect a capacitor between AVCC and AVSS.
Reset input	$\overline{\text{RESET}}$	I	Driving this pin low resets the MCU.
MODE	MODE	I	Connect this pin to VCC via a resistor.
Power-off mode exit input	$\overline{\text{WKUP0}}$	I	This pin is provided for input to exit the mode used in power-off mode. Connect to VSS when not using power-off mode.
XIN clock input	XIN	I	These pins are provided for XIN clock generation circuit I/O. Connect a ceramic oscillator or a crystal oscillator between pins XIN and XOUT. <sup>(1)</sup> To use an external clock, input it to the XIN pin and leave the XOUT pin open.
XIN clock output	XOUT	O	
XCIN clock input	XCIN	I	These pins are provided for XCIN clock generation circuit I/O. Connect a crystal oscillator between pins XCIN and XCOU. <sup>(1)</sup> To use an external clock, input it to the XCIN pin and leave the XCOU pin open.
XCIN clock output	XCOU	O	
$\overline{\text{INT}}$ interrupt input	$\overline{\text{INT0}}$ to $\overline{\text{INT7}}$	I	$\overline{\text{INT}}$ interrupt input pins.
Key input interrupt	$\overline{\text{KI0}}$ to $\overline{\text{KI7}}$	I	Key input interrupt input pins
Timer RA	TRAIO	I/O	Timer RA I/O pin
	TRAO	O	Timer RA output pin
Timer RB	TRBO	O	Timer RB output pin
Timer RC	TRCLK	I	External clock input pin
	TRCTRG	I	External trigger input pin
	TRCIOA, TRCIOB, TRCIOC, TRCIOD	I/O	Timer RC I/O pins
Timer RD	TRDIOA0, TRDIOA1, TRDIOB0, TRDIOB1, TRDIOC0, TRDIOC1, TRDIOD0, TRDIOD1	I/O	Timer RD I/O pins
	TRDCLK	I	External clock input pin
Timer RE	TREO	O	Divided clock output pin
Timer RG	TRGCLKA, TRGCLKB	I	Timer RG input pins
	TRGIOA, TRGIOB	I/O	Timer RG I/O pins
Serial interface	CLK0, CLK1, CLK2	I/O	Transfer clock I/O pins
	RXD0, RXD1, RXD2	I	Serial data input pins
	TXD0, TXD1, TXD2	O	Serial data output pins
	$\overline{\text{CTS2}}$	I	Transmission control input pin
	$\overline{\text{RTS2}}$	O	Reception control output pin
	SCL2	I/O	I <sup>2</sup> C mode clock I/O pin
	SDA2	I/O	I <sup>2</sup> C mode data I/O pin

I: Input      O: Output      I/O: Input and output

Note:

1. Contact the oscillator manufacturer for oscillation characteristics.

**Table 1.15 Pin Functions for R8C/L3AC Group (2)**

Item	Pin Name	I/O Type	Description
I <sup>2</sup> C bus	SCL	I/O	Clock I/O pin
	SDA	I/O	Data I/O pin
SSU	SSI	I/O	Data I/O pin
	$\overline{\text{SCS}}$	I/O	Chip-select signal I/O pin
	SSCK	I/O	Clock I/O pin
	SSO	I/O	Data I/O pin
Reference voltage input	VREF	I	Reference voltage input pin for the A/D converter and the D/A converter
A/D converter	AN0 to AN11	I	A/D converter analog input pins
	$\overline{\text{ADTRG}}$	I	A/D external trigger input pin
D/A converter	DA0, DA1	O	D/A converter output pins
Comparator B	IVCMP1, IVCMP3	I	Comparator B analog voltage input pins
	IVREF1, IVREF3	I	Comparator B reference voltage input pins
I/O ports	P0_0 to P0_7, P1_0 to P1_7, P2_0 to P2_7, P3_0 to P3_7, P4_0 to P4_7, P5_0, P5_3, P6_0 to P6_7, P7_0 to P7_7, P10_0 to P10_7, P11_0 to P11_7, P12_0 to P12_3, P13_0 to P13_7	I/O	CMOS I/O ports. Each port has an I/O select direction register, allowing each pin in the port to be directed for input or output individually. Any port set to input can be set to use a pull-up resistor or not by a program. Ports P10_0 to P10_7 and P11_0 to P11_7 can be used as LED drive ports.
Segment output	SEG0 to SEG55	O	LCD segment output pins
Common output	COM0 to COM7	O	LCD common output pins
Voltage multiplier capacity connect pins	CL1, CL2	O	Connect pins for the LCD control voltage multiplier
LCD power supply	VL1	I/O	Apply the voltage: $0 \leq \text{VL1} \leq \text{VL2} \leq \text{VL3} \leq \text{VL4}$ .
	VL2 to VL4	I	VL1 can be used as the reference potential input or output pin when setting the voltage multiplier.

I: Input      O: Output      I/O: Input and output

Note:

1. Contact the oscillator manufacturer for oscillation characteristics.



## 2. Central Processing Unit (CPU)

Figure 2.1 shows the CPU Registers. The CPU contains 13 registers. R0, R1, R2, R3, A0, A1, and FB configure a register bank. There are two sets of register banks.

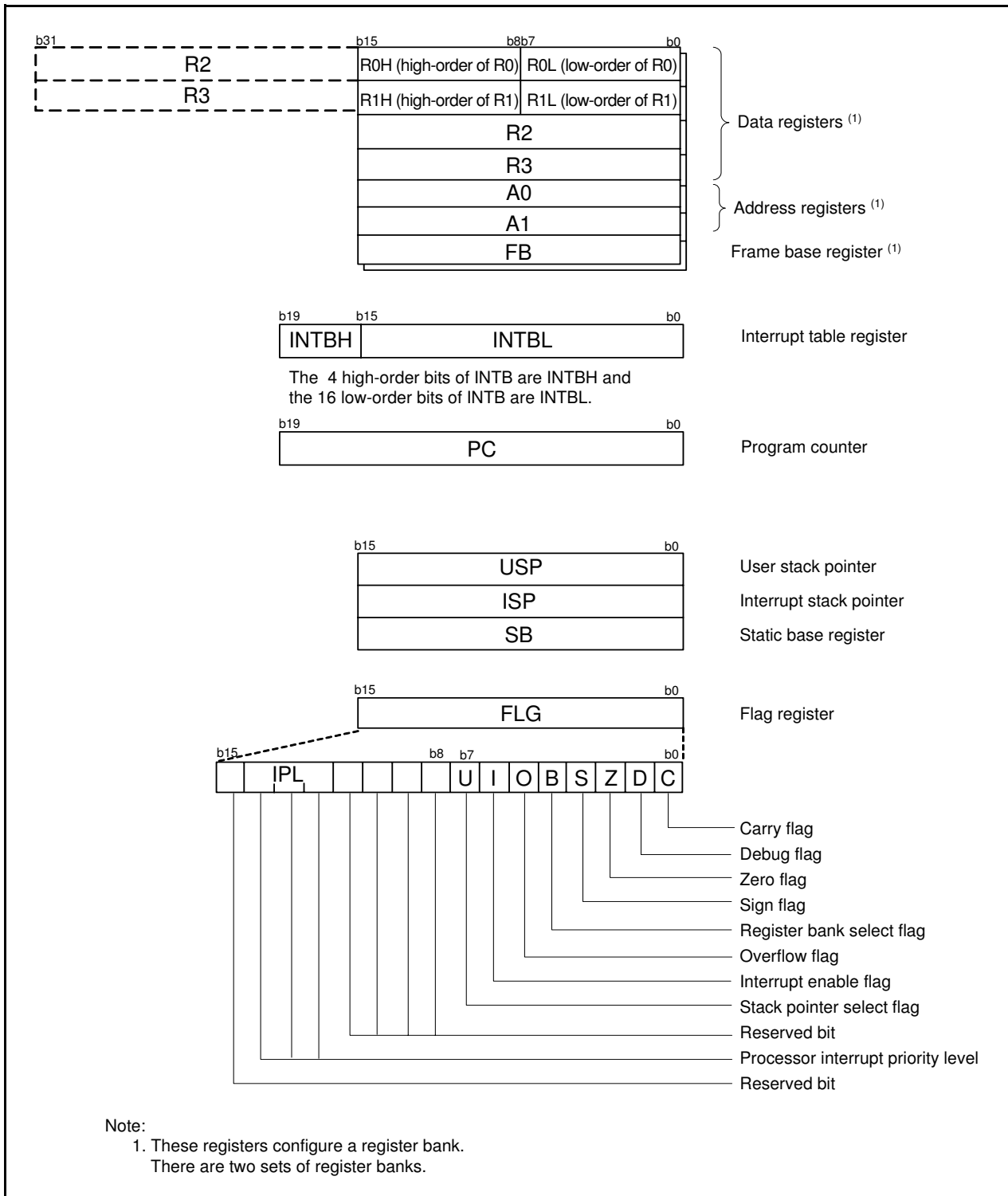


Figure 2.1 CPU Registers

## 2.1 Data Registers (R0, R1, R2, and R3)

R0 is a 16-bit register for transfer, arithmetic, and logic operations. The same applies to R1 to R3. R0 can be split into high-order bits (R0H) and low-order bits (R0L) to be used separately as 8-bit data registers. R1H and R1L are analogous to R0H and R0L. R2 can be combined with R0 and used as a 32-bit data register (R2R0). R3R1 is analogous to R2R0.

## 2.2 Address Registers (A0 and A1)

A0 is a 16-bit register for address register indirect addressing and address register relative addressing. It is also used for transfer, arithmetic, and logic operations. A1 is analogous to A0. A1 can be combined with A0 and as a 32-bit address register (A1A0).

## 2.3 Frame Base Register (FB)

FB is a 16-bit register for FB relative addressing.

## 2.4 Interrupt Table Register (INTB)

INTB is a 20-bit register that indicates the starting address of an interrupt vector table.

## 2.5 Program Counter (PC)

PC is 20 bits wide and indicates the address of the next instruction to be executed.

## 2.6 User Stack Pointer (USP) and Interrupt Stack Pointer (ISP)

The stack pointers (SP), USP and ISP, are each 16 bits wide. The U flag of FLG is used to switch between USP and ISP.

## 2.7 Static Base Register (SB)

SB is a 16-bit register for SB relative addressing.

## 2.8 Flag Register (FLG)

FLG is an 11-bit register indicating the CPU state.

### 2.8.1 Carry Flag (C)

The C flag retains carry, borrow, or shift-out bits that have been generated by the arithmetic and logic unit.

### 2.8.2 Debug Flag (D)

The D flag is for debugging only. Set it to 0.

### 2.8.3 Zero Flag (Z)

The Z flag is set to 1 when an arithmetic operation results in 0; otherwise to 0.

### 2.8.4 Sign Flag (S)

The S flag is set to 1 when an arithmetic operation results in a negative value; otherwise to 0.

### 2.8.5 Register Bank Select Flag (B)

Register bank 0 is selected when the B flag is 0. Register bank 1 is selected when this flag is set to 1.

### 2.8.6 Overflow Flag (O)

The O flag is set to 1 when an operation results in an overflow; otherwise to 0.

### **2.8.7 Interrupt Enable Flag (I)**

The I flag enables maskable interrupts.

Interrupts are disabled when the I flag is set to 0, and are enabled when the I flag is set to 1. The I flag is set to 0 when an interrupt request is acknowledged.

### **2.8.8 Stack Pointer Select Flag (U)**

ISP is selected when the U flag is set to 0; USP is selected when the U flag is set to 1.

The U flag is set to 0 when a hardware interrupt request is acknowledged or the INT instruction of software interrupt numbers 0 to 31 is executed.

### **2.8.9 Processor Interrupt Priority Level (IPL)**

IPL is 3 bits wide and assigns processor interrupt priority levels from level 0 to level 7.

If a requested interrupt has higher priority than IPL, the interrupt is enabled.

### **2.8.10 Reserved Bit**

If necessary, set to 0. When read, the content is undefined.

### 3. Memory

Figure 3.1 is a Memory Map of each group. Each group has a 1-Mbyte address space from addresses 00000h to FFFFFh. For example, a 48-Kbyte internal ROM area is allocated addresses 04000h to 0FFFFh.

The fixed interrupt vector table is allocated addresses 0FFDCh to 0FFFFh. The starting address of each interrupt routine is stored here.

The internal ROM (data flash) is allocated addresses 03000h to 03FFFh.

The internal RAM is allocated higher addresses, beginning with address 00400h. For example, a 6-Kbyte internal RAM area is allocated addresses 00400h to 01BFFh. The internal RAM is used not only for data storage but also as a stack area when a subroutine is called or when an interrupt request is acknowledged.

Special function registers (SFRs) are allocated addresses 00000h to 002FFh and 02C00h to 02FFFh. Peripheral function control registers are allocated here. All unallocated spaces within the SFRs are reserved and cannot be accessed by users.

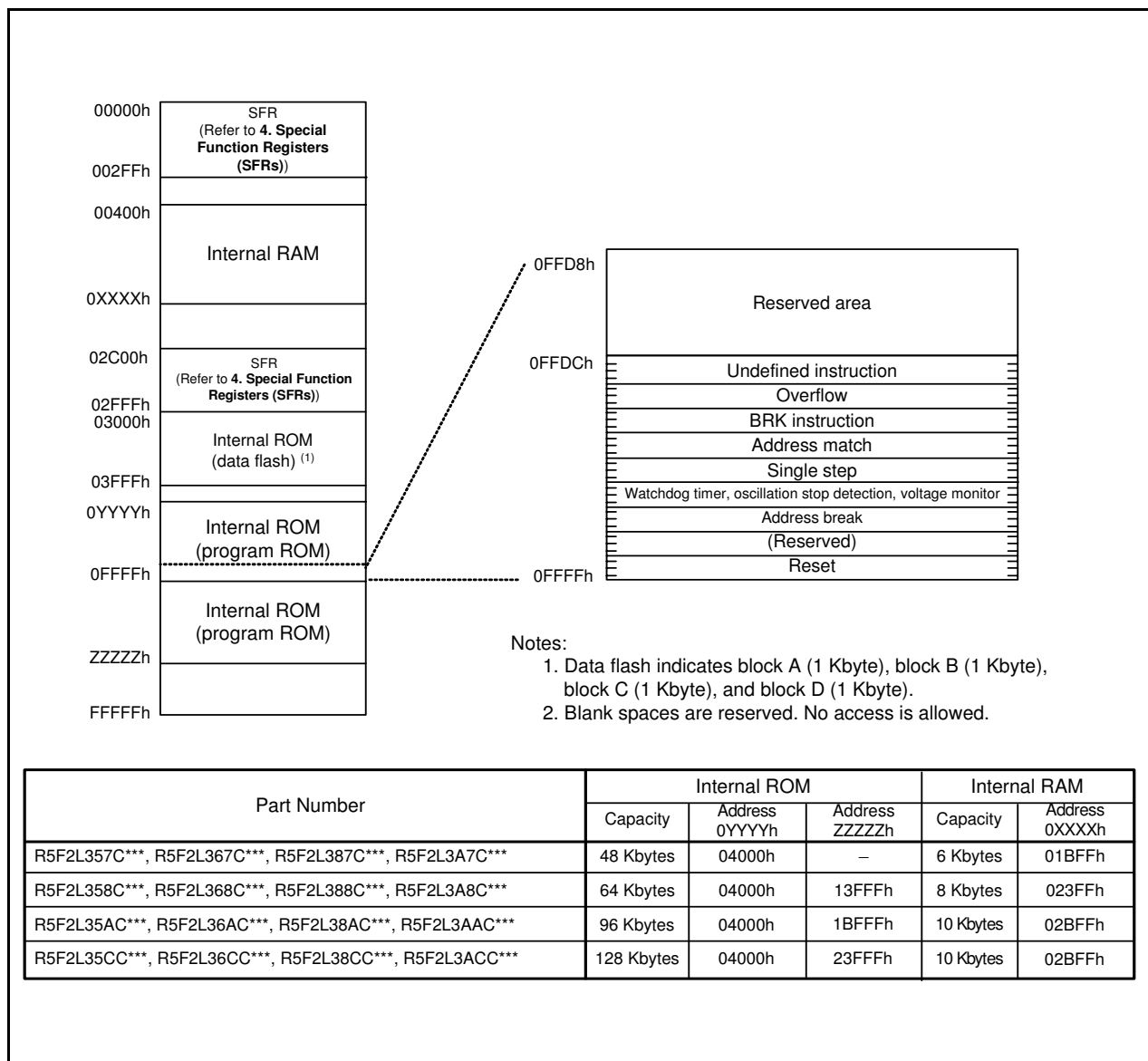


Figure 3.1 Memory Map

## 4. Special Function Registers (SFRs)

An SFR (special function register) is a control register for a peripheral function. Tables 4.1 to 4.16 list SFR Informations and Table 4.17 lists the ID Code Areas and Option Function Select Area. The description offered in this chapter is based on the R8C/L3AC Group.

**Table 4.1 SFR Information (1) (1)**

Address	Register	Symbol	After Reset
0000h			
0001h			
0002h			
0003h			
0004h	Processor Mode Register 0	PM0	00h
0005h	Processor Mode Register 1	PM1	00h
0006h	System Clock Control Register 0	CM0	00100000b
0007h	System Clock Control Register 1	CM1	00100000b
0008h	Module Standby Control Register	MSTCR	00h
0009h	System Clock Control Register 3	CM3	00h
000Ah	Protect Register	PRCR	00h
000Bh	Reset Source Determination Register	RSTFR	XXh (2)
000Ch	Oscillation Stop Detection Register	OCD	00000100b
000Dh	Watchdog Timer Reset Register	WDTR	XXh
000Eh	Watchdog Timer Start Register	WDTs	XXh
000Fh	Watchdog Timer Control Register	WDTC	00111111b
0010h			
0011h			
0012h			
0013h			
0014h			
0015h	High-Speed On-Chip Oscillator Control Register 7	FRA7	When shipping
0016h			
0017h			
0018h			
0019h			
001Ah			
001Bh			
001Ch	Count Source Protection Mode Register	CSPR	00h 10000000b (3)
001Dh			
001Eh			
001Fh			
0020h	Power-Off Mode Control Register 0	POMCR0	X0000000b
0021h			
0022h			
0023h	High-Speed On-Chip Oscillator Control Register 0	FRA0	00h
0024h	High-Speed On-Chip Oscillator Control Register 1	FRA1	When shipping
0025h	High-Speed On-Chip Oscillator Control Register 2	FRA2	00h
0026h	On-Chip Reference Voltage Control Register	OCVREFCR	00h
0027h			
0028h			
0029h	High-Speed On-Chip Oscillator Control Register 4	FRA4	When Shipping
002Ah	High-Speed On-Chip Oscillator Control Register 5	FRA5	When Shipping
002Bh	High-Speed On-Chip Oscillator Control Register 6	FRA6	When Shipping
002Ch			
002Dh			
002Eh			
002Fh	High-Speed On-Chip Oscillator Control Register 3	FRA3	When shipping
0030h	Voltage Monitor Circuit Control Register	CMPA	00h
0031h	Voltage Monitor Circuit Edge Select Register	VCAC	00h
0032h			
0033h	Voltage Detect Register 1	VCA1	00001000b
0034h	Voltage Detect Register 2	VCA2	00h (4) 00100000b (5)
0035h			
0036h	Voltage Detection 1 Level Select Register	VD1LS	00000111b
0037h			
0038h	Voltage Monitor 0 Circuit Control Register	VW0C	1100X010b (4) 1100X011b (5)
0039h	Voltage Monitor 1 Circuit Control Register	VW1C	10001010b

X: Undefined

Notes:

- Blank spaces are reserved. No access is allowed.
- The CWR bit in the RSTFR register is set to 0 after power-on, voltage monitor 0 reset, or exit from power-off mode. Hardware reset, software reset, or watchdog timer reset does not affect this bit.
- The CSPROINI bit in the OFS register is set to 0.
- The LVDAS bit in the OFS register is set to 1.
- The LVDAS bit in the OFS register is set to 0.

**Table 4.2 SFR Information (2) (1)**

Address	Register	Symbol	After Reset
003Ah	Voltage Monitor 2 Circuit Control Register	VW2C	1000010b
003Bh			
003Ch			
003Dh			
003Eh			
003Fh			
0040h			
0041h	Flash Memory Ready Interrupt Control Register	FMRDYIC	XXXXX000b
0042h			
0043h	INT7 Interrupt Control Register	INT7IC	XX00X000b
0044h	INT6 Interrupt Control Register	INT6IC	XX00X000b
0045h	INT5 Interrupt Control Register	INT5IC	XX00X000b
0046h	INT4 Interrupt Control Register	INT4IC	XX00X000b
0047h	Timer RC Interrupt Control Register	TRCIC	XXXXX000b
0048h	Timer RDO Interrupt Control Register	TRDOIC	XXXXX000b
0049h	Timer RD1 Interrupt Control Register	TRD1IC	XXXXX000b
004Ah	Timer RE Interrupt Control Register	TREIC	XXXXX000b
004Bh	UART2 Transmit Interrupt Control Register	S2TIC	XXXXX000b
004Ch	UART2 Receive Interrupt Control Register	S2RIC	XXXXX000b
004Dh	Key Input Interrupt Control Register	KUPIC	XXXXX000b
004Eh	A/D Conversion Interrupt Control Register	ADIC	XXXXX000b
004Fh	SSU Interrupt Control Register / IIC bus Interrupt Control Register (2)	SSUIC/IICIC	XXXXX000b
0050h			
0051h	UART0 Transmit Interrupt Control Register	S0TIC	XXXXX000b
0052h	UART0 Receive Interrupt Control Register	S0RIC	XXXXX000b
0053h	UART1 Transmit Interrupt Control Register	S1TIC	XXXXX000b
0054h	UART1 Receive Interrupt Control Register	S1RIC	XXXXX000b
0055h	INT2 Interrupt Control Register	INT2IC	XX00X000b
0056h	Timer RA Interrupt Control Register	TRAIC	XXXXX000b
0057h			
0058h	Timer RB Interrupt Control Register	TRBIC	XXXXX000b
0059h	INT1 Interrupt Control Register	INT1IC	XX00X000b
005Ah	INT3 Interrupt Control Register	INT3IC	XX00X000b
005Bh			
005Ch			
005Dh	INT0 Interrupt Control Register	INT0IC	XX00X000b
005Eh	UART2 Bus Collision Detection Interrupt Control Register	U2BCNIC	XXXXX000b
005Fh			
0060h			
0061h			
0062h			
0063h			
0064h			
0065h			
0066h			
0067h			
0068h			
0069h			
006Ah			
006Bh	Timer RG Interrupt Control Register	TRGIC	XXXXX000b
006Ch			
006Dh			
006Eh			
006Fh			
0070h			
0071h			
0072h	Voltage monitor 1 Interrupt Control Register	VCMP1IC	XXXXX000b
0073h	Voltage monitor 2 Interrupt Control Register	VCMP2IC	XXXXX000b
0074h			
0075h			
0076h			
0077h			
0078h			
0079h			
007Ah			
007Bh			
007Ch			
007Dh			
007Eh			
007Fh			

X: Undefined

Notes:

- Blank spaces are reserved. No access is allowed.
- Selectable by the IICSEL bit in the SSUICSR register.

**Table 4.3 SFR Information (3) (1)**

Address	Register	Symbol	After Reset
0080h	DTC Activation Control Register	DTCTL	00h
0081h			
0082h			
0083h			
0084h			
0085h			
0086h			
0087h			
0088h	DTC Activation Enable Register 0	DTCEN0	00h
0089h	DTC Activation Enable Register 1	DTCEN1	00h
008Ah	DTC Activation Enable Register 2	DTCEN2	00h
008Bh	DTC Activation Enable Register 3	DTCEN3	00h
008Ch	DTC Activation Enable Register 4	DTCEN4	00h
008Dh	DTC Activation Enable Register 5	DTCEN5	00h
008Eh	DTC Activation Enable Register 6	DTCEN6	00h
008Fh			
0090h			
0091h			
0092h			
0093h			
0094h			
0095h			
0096h			
0097h			
0098h			
0099h			
009Ah			
009Bh			
009Ch			
009Dh			
009Eh			
009Fh			
00A0h	UART0 Transmit/Receive Mode Register	U0MR	00h
00A1h	UART0 Bit Rate Register	U0BRG	XXh
00A2h	UART0 Transmit Buffer Register	U0TB	XXh
00A3h			XXh
00A4h	UART0 Transmit/Receive Control Register 0	U0C0	00001000b
00A5h	UART0 Transmit/Receive Control Register 1	U0C1	00000010b
00A6h	UART0 Receive Buffer Register	U0RB	XXh
00A7h			XXh
00A8h	UART2 Transmit/Receive Mode Register	U2MR	00h
00A9h	UART2 Bit Rate Register	U2BRG	XXh
00AAh	UART2 Transmit Buffer Register	U2TB	XXh
00ABh			XXh
00ACh	UART2 Transmit/Receive Control Register 0	U2C0	00001000b
00ADh	UART2 Transmit/Receive Control Register 1	U2C1	00000010b
00AEh	UART2 Receive Buffer Register	U2RB	XXh
00AFh			XXh
00B0h	UART2 Digital Filter Function Select Register	URXDF	00h
00B1h			
00B2h			
00B3h			
00B4h			
00B5h			
00B6h			
00B7h			
00B8h			
00B9h			
00BAh			
00BBh	UART2 Special Mode Register 5	U2SMR5	00h
00BCh	UART2 Special Mode Register 4	U2SMR4	00h
00BDh	UART2 Special Mode Register 3	U2SMR3	000X0X0Xb
00BEh	UART2 Special Mode Register 2	U2SMR2	X0000000b
00BFh	UART2 Special Mode Register	U2SMR	X0000000b

X: Undefined

Note:

- Blank spaces are reserved. No access is allowed.

**Table 4.4 SFR Information (4) (1)**

Address	Register	Symbol	After Reset
00C0h	A/D Register 0	AD0	XXh
00C1h			000000XXb
00C2h	A/D Register 1	AD1	XXh
00C3h			000000XXb
00C4h	A/D Register 2	AD2	XXh
00C5h			000000XXb
00C6h	A/D Register 3	AD3	XXh
00C7h			000000XXb
00C8h	A/D Register 4	AD4	XXh
00C9h			000000XXb
00CAh	A/D Register 5	AD5	XXh
00CBh			000000XXb
00CCh	A/D Register 6	AD6	XXh
00CDh			000000XXb
00CEh	A/D Register 7	AD7	XXh
00CFh			000000XXb
00D0h			
00D1h			
00D2h			
00D3h			
00D4h	A/D Mode Register	ADMOD	00h
00D5h	A/D Input Select Register	ADINSEL	11000000b
00D6h	A/D Control Register 0	ADCON0	00h
00D7h	A/D Control Register 1	ADCON1	00h
00D8h	D/A 0 Register	DA0	00h
00D9h	D/A 1 Register	DA1	00h
00DAh			
00DBh			
00DCh	D/A Control Register	DACON	00h
00DDh			
00DEh			
00DFh			
00E0h	Port P0 Register	P0	XXh
00E1h	Port P1 Register	P1	XXh
00E2h	Port P0 Direction Register	PD0	00h
00E3h	Port P1 Direction Register	PD1	00h
00E4h	Port P2 Register	P2	XXh
00E5h	Port P3 Register	P3	XXh
00E6h	Port P2 Direction Register	PD2	00h
00E7h	Port P3 Direction Register	PD3	00h
00E8h	Port P4 Register	P4	XXh
00E9h	Port P5 Register	P5	XXh
00EAh	Port P4 Direction Register	PD4	00h
00EBh	Port P5 Direction Register	PD5	00h
00ECh	Port P6 Register	P6	XXh
00EDh	Port P7 Register	P7	XXh
00EEh	Port P6 Direction Register	PD6	00h
00EFh	Port P7 Direction Register	PD7	00h
00F0h			
00F1h			
00F2h			
00F3h			
00F4h	Port P10 Register	P10	XXh
00F5h	Port P11 Register	P11	XXh
00F6h	Port P10 Direction Register	PD10	00h
00F7h	Port P11 Direction Register	PD11	00h
00F8h	Port P12 Register	P12	XXh
00F9h	Port P13 Register	P13	XXh
00FAh	Port P12 Direction Register	PD12	00h
00FBh	Port P13 Direction Register	PD13	00h
00FCh			
00FDh			
00FEh			
00FFh			

X: Undefined

Note:

- Blank spaces are reserved. No access is allowed.



**Table 4.5 SFR Information (5) (1)**

Address	Register	Symbol	After Reset
0100h	Timer RA Control Register	TRACR	00h
0101h	Timer RA I/O Control Register	TRAIOC	00h
0102h	Timer RA Mode Register	TRAMR	00h
0103h	Timer RA Prescaler Register	TRAPRE	FFh
0104h	Timer RA Register	TRA	FFh
0105h	LIN Control Register 2	LINCR2	00h
0106h	LIN Control Register	LINCR	00h
0107h	LIN Status Register	LINST	00h
0108h	Timer RB Control Register	TRBCR	00h
0109h	Timer RB One-Shot Control Register	TRBOCR	00h
010Ah	Timer RB I/O Control Register	TRBIOC	00h
010Bh	Timer RB Mode Register	TRBMR	00h
010Ch	Timer RB Prescaler Register	TRBPRE	FFh
010Dh	Timer RB Secondary Register	TRBSC	FFh
010Eh	Timer RB Primary Register	TRBPR	FFh
010Fh			
0110h			
0111h			
0112h			
0113h			
0114h			
0115h			
0116h			
0117h			
0118h	Timer RE Second Data Register / Timer RE Counter Data Register	TRESEC	XXh
0119h	Timer RE Minute Data Register / Timer RE Compare Data Register	TREMIN	XXh
011Ah	Timer RE Hour Data Register	TREHR	XXh
011Bh	Timer RE Day of Week Data Register	TREWK	XXh
011Ch	Timer RE Control Register 1	TRECR1	XXXXX0XXb
011Dh	Timer RE Control Register 2	TRECR2	XXh
011Eh	Timer RE Count Source Select Register	TRECSR	00001000b
011Fh			
0120h	Timer RC Mode Register	TRCMR	01001000b
0121h	Timer RC Control Register 1	TRCCR1	00h
0122h	Timer RC Interrupt Enable Register	TRCIER	01110000b
0123h	Timer RC Status Register	TRCSR	01110000b
0124h	Timer RC I/O Control Register 0	TRCIOR0	10001000b
0125h	Timer RC I/O Control Register 1	TRCIOR1	10001000b
0126h	Timer RC Counter	TRC	00h
0127h			00h
0128h	Timer RC General Register A	TRCGRA	FFh
0129h			FFh
012Ah	Timer RC General Register B	TRCGRB	FFh
012Bh			FFh
012Ch	Timer RC General Register C	TRCGRC	FFh
012Dh			FFh
012Eh	Timer RC General Register D	TRCGRD	FFh
012Fh			FFh
0130h	Timer RC Control Register 2	TRCCR2	00011000b
0131h	Timer RC Digital Filter Function Select Register	TRCDF	00h
0132h	Timer RC Output Master Enable Register	TRCOER	01111111b
0133h	Timer RC Trigger Control Register	TRCADCR	00h
0134h			
0135h	Timer RD Control Expansion Register	TRDECR	00h
0136h	Timer RD Trigger Control Register	TRDADCR	00h
0137h	Timer RD Start Register	TRDSTR	11111100b
0138h	Timer RD Mode Register	TRDMR	00001110b
0139h	Timer RD PWM Mode Register	TRDPMR	10001000b
013Ah	Timer RD Function Control Register	TRDFCR	10000000b
013Bh	Timer RD Output Master Enable Register 1	TRDOER1	FFh
013Ch	Timer RD Output Master Enable Register 2	TRDOER2	01111111b
013Dh	Timer RD Output Control Register	TRDOCR	00h
013Eh	Timer RD Digital Filter Function Select Register 0	TRDDF0	00h
013Fh	Timer RD Digital Filter Function Select Register 1	TRDDF1	00h

X: Undefined

Note:

- Blank spaces are reserved. No access is allowed.

**Table 4.6 SFR Information (6) (1)**

Address	Register	Symbol	After Reset
0140h	Timer RD Control Register 0	TRDCR0	00h
0141h	Timer RD I/O Control Register A0	TRDIORA0	10001000b
0142h	Timer RD I/O Control Register C0	TRDIORC0	10001000b
0143h	Timer RD Status Register 0	TRDSR0	11100000b
0144h	Timer RD Interrupt Enable Register 0	TRDIER0	11100000b
0145h	Timer RD PWM Mode Output Level Control Register 0	TRDPOCR0	11111000b
0146h	Timer RD Counter 0	TRD0	00h
0147h			00h
0148h	Timer RD General Register A0	TRDGRA0	FFh
0149h			FFh
014Ah	Timer RD General Register B0	TRDGRB0	FFh
014Bh			FFh
014Ch	Timer RD General Register C0	TRDGRC0	FFh
014Dh			FFh
014Eh	Timer RD General Register D0	TRDGRD0	FFh
014Fh			FFh
0150h	Timer RD Control Register 1	TRDCR1	00h
0151h	Timer RD I/O Control Register A1	TRDIORA1	10001000b
0152h	Timer RD I/O Control Register C1	TRDIORC1	10001000b
0153h	Timer RD Status Register 1	TRDSR1	11000000b
0154h	Timer RD Interrupt Enable Register 1	TRDIER1	11100000b
0155h	Timer RD PWM Mode Output Level Control Register 1	TRDPOCR1	11111000b
0156h	Timer RD Counter 1	TRD1	00h
0157h			00h
0158h	Timer RD General Register A1	TRDGRA1	FFh
0159h			FFh
015Ah	Timer RD General Register B1	TRDGRB1	FFh
015Bh			FFh
015Ch	Timer RD General Register C1	TRDGRC1	FFh
015Dh			FFh
015Eh	Timer RD General Register D1	TRDGRD1	FFh
015Fh			FFh
0160h	UART1 Transmit/Receive Mode Register	U1MR	00h
0161h	UART1 Bit Rate Register	U1BRG	XXh
0162h	UART1 Transmit Buffer Register	U1TB	XXh
0163h			XXh
0164h	UART1 Transmit/Receive Control Register 0	U1C0	00001000b
0165h	UART1 Transmit/Receive Control Register 1	U1C1	0000010b
0166h	UART1 Receive Buffer Register	U1RB	XXh
0167h			XXh
0168h			
0169h			
016Ah			
016Bh			
016Ch			
016Dh			
016Eh			
016Fh			
0170h	Timer RG Mode Register	TRGMR	01000000b
0171h	Timer RG Count Control Register	TRGCNTC	00h
0172h	Timer RG Control Register	TRGCR	10000000b
0173h	Timer RG Interrupt Enable Register	TRGIER	11110000b
0174h	Timer RG Status Register	TRGSR	11100000b
0175h	Timer RG I/O Control Register	TRGIOR	00h
0176h	Timer RG Counter	TRG	00h
0177h			00h
0178h	Timer RG General Register A	TRGGRA	FFh
0179h			FFh
017Ah	Timer RG General Register B	TRGGRB	FFh
017Bh			FFh
017Ch	Timer RG General Register C	TRGGRC	FFh
017Dh			FFh
017Eh	Timer RG General Register D	TRGGRD	FFh
017Fh			FFh

X: Undefined

Note:

- Blank spaces are reserved. No access is allowed.

**Table 4.7 SFR Information (7) (1)**

Address	Register	Symbol	After Reset
0180h	Timer RA Pin Select Register	TRASR	00h
0181h	Timer RB/RC Pin Select Register	TRBRCSR	00h
0182h	Timer RC Pin Select Register 0	TRCPSR0	00h
0183h	Timer RC Pin Select Register 1	TRCPSR1	00h
0184h	Timer RD Pin Select Register 0	TRDPSR0	00h
0185h	Timer RD Pin Select Register 1	TRDPSR1	00h
0186h			
0187h	Timer RG Pin Select Register	TRGPSR	00h
0188h	UART0 Pin Select Register	U0SR	00h
0189h	UART1 Pin Select Register	U1SR	00h
018Ah	UART2 Pin Select Register 0	U2SR0	00h
018Bh	UART2 Pin Select Register 1	U2SR1	00h
018Ch	SSU/IIC Pin Select Register	SSUIICSR	00h
018Dh	Key Input Pin Select Register	KISR	00h
018Eh	INT Interrupt Input Pin Select Register	INTSR	00h
018Fh	I/O Function Pin Select Register	PINSR	00h
0190h			
0191h			
0192h			
0193h	SS Bit Counter Register	SSBR	11111000b
0194h	SS Transmit Data Register L / IIC bus Transmit Data Register (2)	SSTDR/ICDRT	FFh
0195h	SS Transmit Data Register H (2)	SSTDRH	FFh
0196h	SS Receive Data Register L / IIC bus Receive Data Register (2)	SSRDR/ICDRR	FFh
0197h	SS Receive Data Register H (2)	SSRDRH	FFh
0198h	SS Control Register H / IIC bus Control Register 1 (2)	SSCRH/ICCR1	00h
0199h	SS Control Register L / IIC bus Control Register 2 (2)	SSCRL/ICCR2	01111101b
019Ah	SS Mode Register / IIC bus Mode Register (2)	SSMR/ICMR	00010000b/00011000b
019Bh	SS Enable Register / IIC bus Interrupt Enable Register (2)	SSEI/ICIER	00h
019Ch	SS Status Register / IIC bus Status Register (2)	SSSR/ICSR	00h/0000X000b
019Dh	SS Mode Register 2 / Slave Address Register (2)	SSMR2/SAR	00h
019Eh			
019Fh			
01A0h			
01A1h			
01A2h			
01A3h			
01A4h			
01A5h			
01A6h			
01A7h			
01A8h			
01A9h			
01AAh			
01ABh			
01ACh			
01ADh			
01AEh			
01AFh			
01B0h			
01B1h			
01B2h	Flash Memory Status Register	FST	10000X00b
01B3h			
01B4h	Flash Memory Control Register 0	FMR0	00h
01B5h	Flash Memory Control Register 1	FMR1	00h
01B6h	Flash Memory Control Register 2	FMR2	00h
01B7h			
01B8h			
01B9h			
01BAh			
01BBh			
01BCh			
01BDh			
01BEh			
01BFh			

X: Undefined

Notes:

- Blank spaces are reserved. No access is allowed.
- Selectable by the IICSEL bit in the SSUIICSR register.

**Table 4.8 SFR Information (8) (1)**

Address	Register	Symbol	After Reset
01C0h	Address Match Interrupt Register 0	RMAD0	XXh
01C1h			XXh
01C2h			0000XXXXb
01C3h	Address Match Interrupt Enable Register 0	AIER0	00h
01C4h			XXh
01C5h	Address Match Interrupt Register 1	RMAD1	XXh
01C6h			XXh
01C7h			0000XXXXb
01C8h	Address Match Interrupt Enable Register 1	AIER1	00h
01C9h			
01CAh			
01CBh			
01CCh			
01CDh			
01CEh			
01CFh			
01D0h			
01D1h			
01D2h			
01D3h			
01D4h			
01D5h			
01D6h			
01D7h			
01D8h			
01D9h			
01DAh			
01DBh			
01DCh			
01DDh			
01DEh			
01DFh			
01E0h	Port P0 Pull-Up Control Register	P0PUR	00h
01E1h	Port P1 Pull-Up Control Register	P1PUR	00h
01E2h	Port P2 Pull-Up Control Register	P2PUR	00h
01E3h	Port P3 Pull-Up Control Register	P3PUR	00h
01E4h	Port P4 Pull-Up Control Register	P4PUR	00h
01E5h	Port P5 Pull-Up Control Register	P5PUR	00h
01E6h	Port P6 Pull-Up Control Register	P6PUR	00h
01E7h	Port P7 Pull-Up Control Register	P7PUR	00h
01E8h			
01E9h			
01EAh	Port 10 Pull-Up Control Register	P10PUR	00h
01EBh	Port 11 Pull-Up Control Register	P11PUR	00h
01ECh	Port 12 Pull-Up Control Register	P12PUR	00h
01EDh	Port 13 Pull-Up Control Register	P13PUR	00h
01EEh			
01EFh			
01F0h	Port P10 Drive Capacity Control Register	P10DRR	00h
01F1h	Port P11 Drive Capacity Control Register	P11DRR	00h
01F2h			
01F3h			
01F4h			
01F5h	Input Threshold Control Register 0	VLT0	00h
01F6h	Input Threshold Control Register 1	VLT1	00h
01F7h	Input Threshold Control Register 2	VLT2	00h
01F8h	Comparator B Control Register 0	INTCMP	00h
01F9h			
01FAh	External Input Enable Register 0	INTEN	00h
01FBh	External Input Enable Register 1	INTEN1	00h
01FCh	INT Input Filter Select Register 0	INTF	00h
01FDh	INT Input Filter Select Register 1	INTF1	00h
01FEh	Key Input Enable Register 0	KIEN	00h
01FFh	Key Input Enable Register 1	KIEN1	00h

X: Undefined

Note:

- Blank spaces are reserved. No access is allowed.

**Table 4.9 SFR Information (9) (1)**

Address	Register	Symbol	After Reset
0200h	LCD Control Register	LCR0	00h
0201h	LCD Bias Control Register	LCR1	00h
0202h	LCD Display Control Register	LCR2	X0000000b
0203h	LCD Clock Control Register	LCR3	00h
0204h			
0205h			
0206h	LCD Port Select Register 0	LSE0	00h
0207h	LCD Port Select Register 1	LSE1	00h
0208h	LCD Port Select Register 2	LSE2	00h
0209h	LCD Port Select Register 3	LSE3	00h
020Ah	LCD Port Select Register 4	LSE4	00h
020Bh	LCD Port Select Register 5	LSE5	00h
020Ch	LCD Port Select Register 6	LSE6	00h
020Dh	LCD Port Select Register 7	LSE7	00h
020Eh			
020Fh			
0210h	LCD Display Data Register	LRA0L	XXh
0211h		LRA1L	XXh
0212h		LRA2L	XXh
0213h		LRA3L	XXh
0214h		LRA4L	XXh
0215h		LRA5L	XXh
0216h		LRA6L	XXh
0217h		LRA7L	XXh
0218h		LRA8L	XXh
0219h		LRA9L	XXh
021Ah		LRA10L	XXh
021Bh		LRA11L	XXh
021Ch		LRA12L	XXh
021Dh		LRA13L	XXh
021Eh		LRA14L	XXh
021Fh		LRA15L	XXh
0220h		LRA16L	XXh
0221h		LRA17L	XXh
0222h		LRA18L	XXh
0223h		LRA19L	XXh
0224h		LRA20L	XXh
0225h		LRA21L	XXh
0226h		LRA22L	XXh
0227h		LRA23L	XXh
0228h		LRA24L	XXh
0229h		LRA25L	XXh
022Ah		LRA26L	XXh
022Bh		LRA27L	XXh
022Ch		LRA28L	XXh
022Dh		LRA29L	XXh
022Eh		LRA30L	XXh
022Fh		LRA31L	XXh
0230h		LRA32L	XXh
0231h		LRA33L	XXh
0232h		LRA34L	XXh
0233h		LRA35L	XXh
0234h		LRA36L	XXh
0235h		LRA37L	XXh
0236h		LRA38L	XXh
0237h		LRA39L	XXh
0238h		LRA40L	XXh
0239h		LRA41L	XXh
023Ah		LRA42L	XXh
023Bh		LRA43L	XXh
023Ch		LRA44L	XXh
023Dh		LRA45L	XXh
023Eh		LRA46L	XXh
023Fh		LRA47L	XXh

X: Undefined

Note:

- Blank spaces are reserved. No access is allowed.

**Table 4.10 SFR Information (10) (1)**

Address	Register	Symbol	After Reset	
0240h	LCD Display Data Register	LRA48L	XXh	
0241h		LRA49L	XXh	
0242h		LRA50L	XXh	
0243h		LRA51L	XXh	
0244h		LRA52L	XXh	
0245h		LRA53L	XXh	
0246h		LRA54L	XXh	
0247h		LRA55L	XXh	
0248h				
0249h				
024Ah				
024Bh				
024Ch				
024Dh				
024Eh				
024Fh				
0250h				
0251h				
0252h				
0253h				
0254h				
0255h				
0256h				
0257h				
0258h				
0259h				
025Ah				
025Bh				
025Ch				
025Dh				
025Eh				
025Fh				
0260h				
0261h				
0262h				
0263h				
0264h				
0265h				
0266h				
0267h				
0268h				
0269h				
026Ah				
026Bh				
026Ch				
026Dh				
026Eh				
026Fh				
0270h	LCD Display Control Data Register	LRA0H	XXh	
0271h		LRA1H	XXh	
0272h		LRA2H	XXh	
0273h		LRA3H	XXh	
0274h		LRA4H	XXh	
0275h		LRA5H	XXh	
0276h		LRA6H	XXh	
0277h		LRA7H	XXh	
0278h		LRA8H	XXh	
0279h		LRA9H	XXh	
027Ah		LRA10H	XXh	
027Bh		LRA11H	XXh	
027Ch		LRA12H	XXh	
027Dh		LRA13H	XXh	
027Eh		LRA14H	XXh	
027Fh		LRA15H	XXh	

X: Undefined

Note:

- Blank spaces are reserved. No access is allowed.

**Table 4.11 SFR Information (11) (1)**

Address	Register	Symbol	After Reset
0280h	LCD Display Control Data Register	LRA16H	XXh
0281h		LRA17H	XXh
0282h		LRA18H	XXh
0283h		LRA19H	XXh
0284h		LRA20H	XXh
0285h		LRA21H	XXh
0286h		LRA22H	XXh
0287h		LRA23H	XXh
0288h		LRA24H	XXh
0289h		LRA25H	XXh
028Ah		LRA26H	XXh
028Bh		LRA27H	XXh
028Ch		LRA28H	XXh
028Dh		LRA29H	XXh
028Eh		LRA30H	XXh
028Fh		LRA31H	XXh
0290h		LRA32H	XXh
0291h		LRA33H	XXh
0292h		LRA34H	XXh
0293h		LRA35H	XXh
0294h		LRA36H	XXh
0295h		LRA37H	XXh
0296h		LRA38H	XXh
0297h		LRA39H	XXh
0298h		LRA40H	XXh
0299h		LRA41H	XXh
029Ah		LRA42H	XXh
029Bh		LRA43H	XXh
029Ch		LRA44H	XXh
029Dh		LRA45H	XXh
029Eh		LRA46H	XXh
029Fh		LRA47H	XXh
02A0h		LRA48H	XXh
02A1h		LRA49H	XXh
02A2h		LRA50H	XXh
02A3h		LRA51H	XXh
02A4h		LRA52H	XXh
02A5h		LRA53H	XXh
02A6h		LRA54H	XXh
02A7h		LRA55H	XXh
02A8h			
02A9h			
02AAh			
02ABh			
02ACh			
02ADh			
02AEh			
02AFh			
02B0h			
02B1h			
02B2h			
02B3h			
02B4h			
02B5h			
02B6h			
02B7h			
02B8h			
02B9h			
02BAh			
02BBh			
02BCh			
02BDh			
02BEh			
02BFh			

X: Undefined

Note:

- Blank spaces are reserved. No access is allowed.

**Table 4.12 SFR Information (12) (1)**

Address	Register	Symbol	After Reset
02C0h			
02C1h			
02C2h			
02C3h			
02C4h			
02C5h			
02C6h			
02C7h			
02C8h			
02C9h			
02CAh			
02CBh			
02CCh			
02CDh			
02CEh			
02CFh			
02D0h			
02D1h			
02D2h			
02D3h			
02D4h			
02D5h			
02D6h			
02D7h			
02D8h			
02D9h			
02DAh			
02DBh			
02DCh			
02DDh			
02DEh			
02DFh			
02E0h			
02E1h			
02E2h			
02E3h			
02E4h			
02E5h			
02E6h			
02E7h			
02E8h			
02E9h			
02EAh			
02EBh			
02ECh			
02EDh			
02EEh			
02EFh			
02F0h			
02F1h			
02F2h			
02F3h			
02F4h			
02F5h			
02F6h			
02F7h			
02F8h			
02F9h			
02FAh			
02FBh			
02FCh			
02FDh			
02FEh			
02FFh			

X: Undefined

Note:

- Blank spaces are reserved. No access is allowed.



**Table 4.13 SFR Information (13) (1)**

Address	Register	Symbol	After Reset
2C00h	DTC Transfer Vector Area		XXh
2C01h	DTC Transfer Vector Area		XXh
2C02h	DTC Transfer Vector Area		XXh
2C03h	DTC Transfer Vector Area		XXh
2C04h	DTC Transfer Vector Area		XXh
2C05h	DTC Transfer Vector Area		XXh
2C06h	DTC Transfer Vector Area		XXh
2C07h	DTC Transfer Vector Area		XXh
2C08h	DTC Transfer Vector Area		XXh
2C09h	DTC Transfer Vector Area		XXh
2C0Ah	DTC Transfer Vector Area		XXh
:	DTC Transfer Vector Area		XXh
:	DTC Transfer Vector Area		XXh
2C3Ah	DTC Transfer Vector Area		XXh
2C3Bh	DTC Transfer Vector Area		XXh
2C3Ch	DTC Transfer Vector Area		XXh
2C3Dh	DTC Transfer Vector Area		XXh
2C3Eh	DTC Transfer Vector Area		XXh
2C3Fh	DTC Transfer Vector Area		XXh
2C40h	DTC Control Data 0	DTCD0	XXh
2C41h			XXh
2C42h			XXh
2C43h			XXh
2C44h			XXh
2C45h			XXh
2C46h			XXh
2C47h			XXh
2C48h	DTC Control Data 1	DTCD1	XXh
2C49h			XXh
2C4Ah			XXh
2C4Bh			XXh
2C4Ch			XXh
2C4Dh			XXh
2C4Eh			XXh
2C4Fh			XXh
2C50h	DTC Control Data 2	DTCD2	XXh
2C51h			XXh
2C52h			XXh
2C53h			XXh
2C54h			XXh
2C55h			XXh
2C56h			XXh
2C57h			XXh
2C58h	DTC Control Data 3	DTCD3	XXh
2C59h			XXh
2C5Ah			XXh
2C5Bh			XXh
2C5Ch			XXh
2C5Dh			XXh
2C5Eh			XXh
2C5Fh			XXh
2C60h	DTC Control Data 4	DTCD4	XXh
2C61h			XXh
2C62h			XXh
2C63h			XXh
2C64h			XXh
2C65h			XXh
2C66h			XXh
2C67h			XXh
2C68h	DTC Control Data 5	DTCD5	XXh
2C69h			XXh
2C6Ah			XXh
2C6Bh			XXh
2C6Ch			XXh
2C6Dh			XXh
2C6Eh			XXh
2C6Fh			XXh

X: Undefined

Note:

- Blank spaces are reserved. No access is allowed.

**Table 4.14 SFR Information (14) (1)**

Address	Register	Symbol	After Reset
2C70h	DTC Control Data 6	DTCD6	XXh
2C71h			XXh
2C72h			XXh
2C73h			XXh
2C74h			XXh
2C75h			XXh
2C76h			XXh
2C77h			XXh
2C78h	DTC Control Data 7	DTCD7	XXh
2C79h			XXh
2C7Ah			XXh
2C7Bh			XXh
2C7Ch			XXh
2C7Dh			XXh
2C7Eh			XXh
2C7Fh			XXh
2C80h	DTC Control Data 8	DTCD8	XXh
2C81h			XXh
2C82h			XXh
2C83h			XXh
2C84h			XXh
2C85h			XXh
2C86h			XXh
2C87h			XXh
2C88h	DTC Control Data 9	DTCD9	XXh
2C89h			XXh
2C8Ah			XXh
2C8Bh			XXh
2C8Ch			XXh
2C8Dh			XXh
2C8Eh			XXh
2C8Fh			XXh
2C90h	DTC Control Data 10	DTCD10	XXh
2C91h			XXh
2C92h			XXh
2C93h			XXh
2C94h			XXh
2C95h			XXh
2C96h			XXh
2C97h			XXh
2C98h	DTC Control Data 11	DTCD11	XXh
2C99h			XXh
2C9Ah			XXh
2C9Bh			XXh
2C9Ch			XXh
2C9Dh			XXh
2C9Eh			XXh
2C9Fh			XXh
2CA0h	DTC Control Data 12	DTCD12	XXh
2CA1h			XXh
2CA2h			XXh
2CA3h			XXh
2CA4h			XXh
2CA5h			XXh
2CA6h			XXh
2CA7h			XXh
2CA8h	DTC Control Data 13	DTCD13	XXh
2CA9h			XXh
2CAAh			XXh
2CABh			XXh
2CACH			XXh
2CADh			XXh
2CAEh			XXh
2CAFh			XXh

X: Undefined

Note:

- Blank spaces are reserved. No access is allowed.

**Table 4.15 SFR Information (15) (1)**

Address	Register	Symbol	After Reset
2CB0h	DTC Control Data 14	DTCD14	XXh
2CB1h			XXh
2CB2h			XXh
2CB3h			XXh
2CB4h			XXh
2CB5h			XXh
2CB6h			XXh
2CB7h			XXh
2CB8h	DTC Control Data 15	DTCD15	XXh
2CB9h			XXh
2CBAh			XXh
2CBBh			XXh
2CBCh			XXh
2CBDh			XXh
2CBEh			XXh
2CBFh			XXh
2CC0h	DTC Control Data 16	DTCD16	XXh
2CC1h			XXh
2CC2h			XXh
2CC3h			XXh
2CC4h			XXh
2CC5h			XXh
2CC6h			XXh
2CC7h			XXh
2CC8h	DTC Control Data 17	DTCD17	XXh
2CC9h			XXh
2CCAh			XXh
2CCBh			XXh
2CCCh			XXh
2CCDh			XXh
2CCEh			XXh
2CCFh			XXh
2CD0h	DTC Control Data 18	DTCD18	XXh
2CD1h			XXh
2CD2h			XXh
2CD3h			XXh
2CD4h			XXh
2CD5h			XXh
2CD6h			XXh
2CD7h			XXh
2CD8h	DTC Control Data 19	DTCD19	XXh
2CD9h			XXh
2CDAh			XXh
2CDBh			XXh
2CDCh			XXh
2CDDh			XXh
2CDEh			XXh
2CDFh			XXh
2CE0h	DTC Control Data 20	DTCD20	XXh
2CE1h			XXh
2CE2h			XXh
2CE3h			XXh
2CE4h			XXh
2CE5h			XXh
2CE6h			XXh
2CE7h			XXh
2CE8h	DTC Control Data 21	DTCD21	XXh
2CE9h			XXh
2CEAh			XXh
2CEBh			XXh
2CECh			XXh
2CEDh			XXh
2CEEh			XXh
2CEFh			XXh

X: Undefined

Note:

- Blank spaces are reserved. No access is allowed.

**Table 4.16 SFR Information (16) (1)**

Address	Register	Symbol	After Reset		
2CF0h	DTC Control Data 22	DTCD22	XXh		
2CF1h			XXh		
2CF2h			XXh		
2CF3h			XXh		
2CF4h			XXh		
2CF5h			XXh		
2CF6h			XXh		
2CF7h			XXh		
2CF8h	DTC Control Data 23	DTCD23	XXh		
2CF9h			XXh		
2CFAh			XXh		
2CFBh			XXh		
2CFCh			XXh		
2CFDh			XXh		
2CFEh			XXh		
2CFFh			XXh		
2D00h					
:					
2FFh					

X: Undefined

Note:

- Blank spaces are reserved. No access is allowed.

**Table 4.17 ID Code Areas and Option Function Select Area**

Address	Area Name	Symbol	After Reset
:			
FFDBh	Option Function Select Register 2	OFS2	(Note 1)
:			
FFDFh	ID1		(Note 2)
:			
FFE3h	ID2		(Note 2)
:			
FFEBh	ID3		(Note 2)
:			
FFEFh	ID4		(Note 2)
:			
FFF3h	ID5		(Note 2)
:			
FFF7h	ID6		(Note 2)
:			
FFFBh	ID7		(Note 2)
:			
FFFFh	Option Function Select Register	OFS	(Note 1)

Notes:

- The option function select area is allocated in the flash memory, not in the SFRs. Set appropriate values as ROM data by a program. Do not write additions to the option function select area. If the block including the option function select area is erased, the option function select area is set to FFh.  
When blank products are shipped, the option function select area is set to FFh. It is set to the written value after written by the user.  
When factory-programming products are shipped, the value of the option function select area is the value programmed by the user.
- The ID code areas are allocated in the flash memory, not in the SFRs. Set appropriate values as ROM data by a program. Do not write additions to the ID code areas. If the block including the ID code areas is erased, the ID code areas are set to FFh.  
When blank products are shipped, the ID code areas are set to FFh. They are set to the written value after written by the user.  
When factory-programming products are shipped, the value of the ID code areas is the value programmed by the user.

## 5. Electrical Characteristics

### 5.1 Absolute Maximum Ratings

**Table 5.1 Absolute Maximum Ratings**

Symbol	Parameter		Condition	Rated Value	Unit
V <sub>cc</sub> /AV <sub>cc</sub>	Supply voltage			-0.3 to 6.5	V
V <sub>i</sub>	Input voltage	XIN	XIN-XOUT oscillation on (oscillation buffer ON) <sup>(1)</sup>	-0.3 to 1.65	V
		XIN	XIN-XOUT oscillation on (oscillation buffer OFF) <sup>(1)</sup>	-0.3 to V <sub>cc</sub> + 0.3	V
		VL1		-0.3 to VL2	V
		VL2	R8C/L35C	VL1 to VL4	V
			R8C/L36C, R8C/L38C, R8C/L3AC	VL1 to VL3	V
		VL3		VL2 to VL4	V
		VL4		VL3 to 6.5	V
		Other pins		-0.3 to V <sub>cc</sub> + 0.3	V
V <sub>o</sub>	Output voltage	XOUT	XIN-XOUT oscillation on (oscillation buffer ON) <sup>(1)</sup>	-0.3 to 1.65	V
		XOUT	XIN-XOUT oscillation on (oscillation buffer OFF) <sup>(1)</sup>	-0.3 to V <sub>cc</sub> + 0.3	V
		VL1		-0.3 to VL2 <sup>(2)</sup>	V
		VL2	R8C/L35C	VL1 to VL4	V
			R8C/L36C, R8C/L38C, R8C/L3AC	VL1 to VL3	V
		VL3		VL2 to VL4	V
		VL4		-0.3 to 6.5	V
		CL1, CL2		-0.3 to 6.5	V
		COM0 to COM7		-0.3 to VL4	V
		SEG0 to SEG55		-0.3 to VL4	V
		Other pins		-0.3 to V <sub>cc</sub> + 0.3	V
P <sub>d</sub>	Power dissipation		-40°C ≤ T <sub>opr</sub> ≤ 85°C	500	mW
T <sub>opr</sub>	Operating ambient temperature			-20 to 85 (N version) / -40 to 85 (D version)	°C
T <sub>stg</sub>	Storage temperature			-65 to 150	°C

Notes:

- For the register settings for each operation, refer to **7. I/O Ports** and **9. Clock Generation Circuit** in the User's Manual: Hardware.
- The VL1 voltage should be VCC or below.

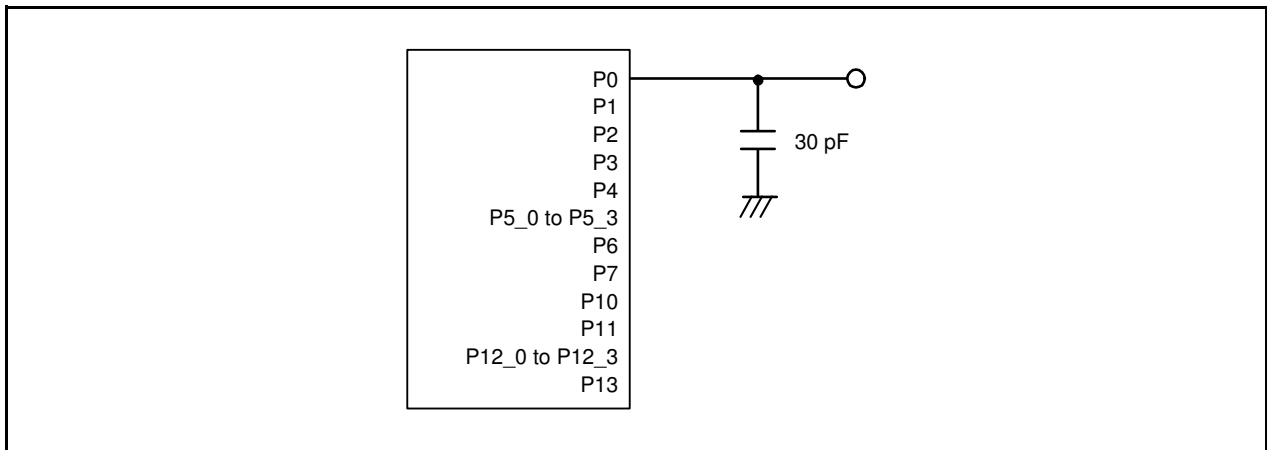
## 5.2 Recommended Operating Conditions

**Table 5.2 Recommended Operating Conditions**  
(VCC = 1.8 to 5.5 V and Topr = -20 to 85°C (N version) / -40 to 85°C (D version), unless otherwise specified.)

Symbol	Parameter		Conditions	Standard			Unit			
				Min.	Typ.	Max.				
VCC/AVCC	Supply voltage			1.8	—	5.5	V			
VSS/AVSS	Supply voltage			—	0	—	V			
VIH	Input "H" voltage	Other than CMOS input		$4.0\text{ V} \leq V_{CC} \leq 5.5\text{ V}$	0.8 VCC	—	VCC	V		
				$2.7\text{ V} \leq V_{CC} < 4.0\text{ V}$	0.8 VCC	—	VCC	V		
				$1.8\text{ V} \leq V_{CC} < 2.7\text{ V}$	0.9 VCC	—	VCC	V		
		CMOS input	Input level switching function (I/O port)	Input level selection : 0.35 VCC		$4.0\text{ V} \leq V_{CC} \leq 5.5\text{ V}$	0.5 VCC	—	VCC	V
						$2.7\text{ V} \leq V_{CC} < 4.0\text{ V}$	0.55 VCC	—	VCC	V
						$1.8\text{ V} \leq V_{CC} < 2.7\text{ V}$	0.65 VCC	—	VCC	V
				Input level selection : 0.5 VCC		$4.0\text{ V} \leq V_{CC} \leq 5.5\text{ V}$	0.65 VCC	—	VCC	V
						$2.7\text{ V} \leq V_{CC} < 4.0\text{ V}$	0.7 VCC	—	VCC	V
						$1.8\text{ V} \leq V_{CC} < 2.7\text{ V}$	0.8 VCC	—	VCC	V
				Input level selection : 0.7 VCC		$4.0\text{ V} \leq V_{CC} \leq 5.5\text{ V}$	0.85 VCC	—	VCC	V
						$2.7\text{ V} \leq V_{CC} < 4.0\text{ V}$	0.85 VCC	—	VCC	V
						$1.8\text{ V} \leq V_{CC} < 2.7\text{ V}$	0.85 VCC	—	VCC	V
VIL	Input "L" voltage	Other than CMOS input		$4.0\text{ V} \leq V_{CC} \leq 5.5\text{ V}$	0	—	0.2 VCC	V		
				$2.7\text{ V} \leq V_{CC} < 4.0\text{ V}$	0	—	0.2 VCC	V		
				$1.8\text{ V} \leq V_{CC} < 2.7\text{ V}$	0	—	0.05 VCC	V		
		CMOS input	Input level switching function (I/O port)	Input level selection : 0.35 VCC		$4.0\text{ V} \leq V_{CC} \leq 5.5\text{ V}$	0	—	0.2 VCC	V
						$2.7\text{ V} \leq V_{CC} < 4.0\text{ V}$	0	—	0.2 VCC	V
						$1.8\text{ V} \leq V_{CC} < 2.7\text{ V}$	0	—	0.2 VCC	V
				Input level selection : 0.5 VCC		$4.0\text{ V} \leq V_{CC} \leq 5.5\text{ V}$	0	—	0.4 VCC	V
						$2.7\text{ V} \leq V_{CC} < 4.0\text{ V}$	0	—	0.3 VCC	V
						$1.8\text{ V} \leq V_{CC} < 2.7\text{ V}$	0	—	0.2 VCC	V
				Input level selection : 0.7 VCC		$4.0\text{ V} \leq V_{CC} \leq 5.5\text{ V}$	0	—	0.55 VCC	V
						$2.7\text{ V} \leq V_{CC} < 4.0\text{ V}$	0	—	0.45 VCC	V
						$1.8\text{ V} \leq V_{CC} < 2.7\text{ V}$	0	—	0.35 VCC	V
IOH(sum)	Peak sum output "H" current	Sum of all pins IOH(peak)			—	—	-160	mA		
IOH(sum)	Average sum output "H" current	Sum of all pins IOH(avg)			—	—	-80	mA		
IOH(peak)	Peak output "H" current	Port P10, P11 (2)			—	—	-40	mA		
		Other pins			—	—	-10	mA		
IOH(avg)	Average output "H" current (1)	Port P10, P11 (2)			—	—	-20	mA		
		Other pins			—	—	-5	mA		
IOI(sum)	Peak sum output "L" current	Sum of all pins IOI(peak)			—	—	160	mA		
IOI(sum)	Average sum output "L" current	Sum of all pins IOI(avg)			—	—	80	mA		
IOI(peak)	Peak output "L" current	Port P10, P11 (2)			—	—	40	mA		
		Other pins			—	—	10	mA		
IOI(avg)	Average output "L" current (1)	Port P10, P11 (2)			—	—	20	mA		
		Other pins			—	—	5	mA		
f(XIN)	XIN clock input oscillation frequency		$2.7\text{ V} \leq V_{CC} \leq 5.5\text{ V}$	—	—	20	MHz			
			$1.8\text{ V} \leq V_{CC} < 2.7\text{ V}$	—	—	5	MHz			
f(XCIN)	XCIN clock input oscillation frequency		$1.8\text{ V} \leq V_{CC} \leq 5.5\text{ V}$	—	32.768	50	kHz			
fOCO40M	When used as the count source for timer RC, timer RD, or timer RG (3)		$2.7\text{ V} \leq V_{CC} \leq 5.5\text{ V}$	32	—	40	MHz			
fOCO-F	fOCO-F frequency		$2.7\text{ V} \leq V_{CC} \leq 5.5\text{ V}$	—	—	20	MHz			
			$1.8\text{ V} \leq V_{CC} < 2.7\text{ V}$	—	—	5	MHz			
—	System clock frequency		$2.7\text{ V} \leq V_{CC} \leq 5.5\text{ V}$	—	—	20	MHz			
			$1.8\text{ V} \leq V_{CC} < 2.7\text{ V}$	—	—	5	MHz			
f(BCLK)	CPU clock frequency		$2.7\text{ V} \leq V_{CC} \leq 5.5\text{ V}$	—	—	20	MHz			
			$1.8\text{ V} \leq V_{CC} < 2.7\text{ V}$	—	—	5	MHz			

## Notes:

- The average output current indicates the average value of current measured during 100 ms.
- This applies when the drive capacity of the output transistor is set to High by registers P10DDR and P11DDR. When the drive capacity is set to Low, the value of any other pin applies.
- fOCO40M can be used as the count source for timer RC, timer RD, or timer RG in the range of VCC = 2.7 V to 5.5V.



**Figure 5.1** Ports P0 to P4, P5\_0 to P5\_3, P6, P7, P10, P11, P12\_0 to P12\_3, and P13 Timing Measurement Circuit

### 5.3 Peripheral Function Characteristics

**Table 5.3 A/D Converter Characteristics**  
( $V_{CC}/AV_{CC} = V_{ref} = 2.2$  to  $5.5$  V,  $V_{SS} = 0$  V, and  $T_{opr} = -20$  to  $85^{\circ}\text{C}$  (N version) /  
 $-40$  to  $85^{\circ}\text{C}$  (D version), unless otherwise specified.)

Symbol	Parameter		Conditions	Standard			Unit
				Min.	Typ.	Max.	
—	Resolution		$V_{ref} = AV_{CC}$	—	—	10	Bit
—	Absolute accuracy <sup>(2)</sup>	10-bit mode	$V_{ref} = AV_{CC} = 5.0$ V AN0 to AN19 input	—	—	$\pm 3$	LSB
			$V_{ref} = AV_{CC} = 3.3$ V AN0 to AN19 input	—	—	$\pm 5$	LSB
			$V_{ref} = AV_{CC} = 3.0$ V AN0 to AN19 input	—	—	$\pm 5$	LSB
			$V_{ref} = AV_{CC} = 2.2$ V AN0 to AN19 input	—	—	$\pm 5$	LSB
		8-bit mode	$V_{ref} = AV_{CC} = 5.0$ V AN0 to AN19 input	—	—	$\pm 2$	LSB
			$V_{ref} = AV_{CC} = 3.3$ V AN0 to AN19 input	—	—	$\pm 2$	LSB
			$V_{ref} = AV_{CC} = 3.0$ V AN0 to AN19 input	—	—	$\pm 2$	LSB
			$V_{ref} = AV_{CC} = 2.2$ V AN0 to AN19 input	—	—	$\pm 2$	LSB
$\phi AD$	A/D conversion clock		$4.0 \leq V_{ref} = AV_{CC} \leq 5.5$ V <sup>(1)</sup>	2	—	20	MHz
			$3.2 \leq V_{ref} = AV_{CC} \leq 5.5$ V <sup>(1)</sup>	2	—	16	MHz
			$2.7 \leq V_{ref} = AV_{CC} \leq 5.5$ V <sup>(1)</sup>	2	—	10	MHz
			$2.2 \leq V_{ref} = AV_{CC} \leq 5.5$ V <sup>(1)</sup>	2	—	5	MHz
—	Tolerance level impedance			—	3	—	k $\Omega$
$t_{CONV}$	Conversion time	10-bit mode	$V_{ref} = AV_{CC} = 5.0$ V, $\phi AD = 20$ MHz	2.2	—	—	$\mu\text{s}$
		8-bit mode	$V_{ref} = AV_{CC} = 5.0$ V, $\phi AD = 20$ MHz	2.2	—	—	$\mu\text{s}$
$t_{SAMP}$	Sampling time		$\phi AD = 20$ MHz	0.8	—	—	$\mu\text{s}$
$I_{Vref}$	$V_{ref}$ current		$V_{CC} = 5$ V, $XIN = f1 = \phi AD = 20$ MHz	—	45	—	$\mu\text{A}$
$V_{ref}$	Reference voltage			2.2	—	$AV_{CC}$	V
$V_{IA}$	Analog input voltage <sup>(3)</sup>			0	—	$V_{ref}$	V
OCVREF	On-chip reference voltage		$2 \text{ MHz} \leq \phi AD \leq 4 \text{ MHz}$	1.19	1.34	1.49	V

## Notes:

1. The A/D conversion result will be undefined in wait mode, stop mode, power-off mode, when the flash memory stops, and in low-current-consumption mode. Do not perform A/D conversion in these states or transition to these states during A/D conversion.
2. This applies when the peripheral functions are stopped.
3. When the analog input voltage is over the reference voltage, the A/D conversion result will be 3FFh in 10-bit mode and FFh in 8-bit mode.



**Table 5.4 D/A Converter Characteristics**  
**( $V_{CC}/AV_{CC} = V_{ref} = 2.7$  to  $5.5$  V and  $T_{opr} = -20$  to  $85^{\circ}\text{C}$  (N version) /  $-40$  to  $85^{\circ}\text{C}$  (D version), unless otherwise specified.)**

Symbol	Parameter	Conditions	Standard			Unit
			Min.	Typ.	Max.	
—	Resolution		—	—	8	Bit
—	Absolute accuracy		—	—	2.5	LSB
$t_{su}$	Setup time		—	—	3	$\mu\text{s}$
$R_o$	Output resistor		—	6	—	$\text{k}\Omega$
$I_{vref}$	Reference power input current	(Note 1)	—	—	1.5	mA

Note:

1. This applies when one D/A converter is used and the value of the DAI register ( $i = 0$  or  $1$ ) for the unused D/A converter is 00h. The resistor ladder of the A/D converter is not included.

**Table 5.5 Comparator B Characteristics**  
**( $V_{CC} = 2.7$  to  $5.5$  V and  $T_{opr} = -20$  to  $85^{\circ}\text{C}$  (N version) /  $-40$  to  $85^{\circ}\text{C}$  (D version), unless otherwise specified.)**

Symbol	Parameter	Condition	Standard			Unit
			Min.	Typ.	Max.	
$V_{ref}$	IVREF1, IVREF3 input reference voltage		0	—	$V_{CC} - 1.4$	V
$V_i$	IVCMP1, IVCMP3 input voltage		-0.3	—	$V_{CC} + 0.3$	V
—	Offset		—	5	100	mV
$t_d$	Comparator output delay time <sup>(1)</sup>	$V_i = V_{ref} \pm 100$ mV	—	0.1	—	$\mu\text{s}$
$I_{CMP}$	Comparator operating current	$V_{CC} = 5.0$ V	—	17.5	—	$\mu\text{A}$

Note:

1. When the digital filter is disabled.

**Table 5.6 Flash Memory (Program ROM) Characteristics**  
**(VCC = 2.7 to 5.5 V and T<sub>opr</sub> = 0 to 60°C, unless otherwise specified.)**

Symbol	Parameter	Conditions	Standard			Unit
			Min.	Typ.	Max.	
—	Program/erase endurance <sup>(1)</sup>		1,000 <sup>(2)</sup>	—	—	times
—	Byte program time		—	80	500	μs
—	Block erase time		—	0.3	—	s
t <sub>d</sub> (SR-SUS)	Time delay from suspend request until suspend		—	—	5 + CPU clock × 3 cycles	ms
—	Interval from erase start/restart until following suspend request		0	—	—	ms
—	Time from suspend until erase restart		—	—	30+CPU clock × 1 cycle	μs
t <sub>d</sub> (CMDRST-READY)	Time from when command is forcibly terminated until reading is enabled		—	—	30+CPU clock × 1 cycle	μs
—	Program, erase voltage		2.7	—	5.5	V
—	Read voltage		1.8	—	5.5	V
—	Program, erase temperature		0	—	60	°C
—	Data hold time <sup>(6)</sup>	Ambient temperature = 55°C	20	—	—	year

## Notes:

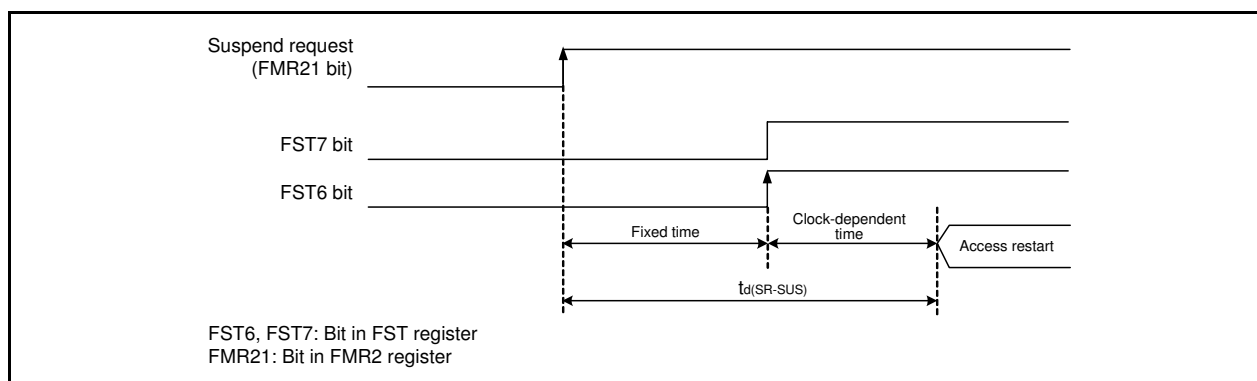
1. Definition of programming/erasure endurance  
 The programming and erasure endurance is defined on a per-block basis.  
 If the programming and erasure endurance is n (n = 1,000), each block can be erased n times. For example, if 1,024 1-byte writes are performed to different addresses in block A, a 1 Kbyte block, and then the block is erased, the programming/erasure endurance still stands at one.  
 However, the same address must not be programmed more than once per erase operation (overwriting prohibited).
2. Endurance to guarantee all electrical characteristics after program and erase. (1 to Min. value can be guaranteed).
3. In a system that executes multiple programming operations, the actual erasure count can be reduced by writing to sequential addresses in turn so that as much of the block as possible is used up before performing an erase operation. For example, when programming groups of 16 bytes, the effective number of rewrites can be minimized by programming up to 128 groups before erasing them all in one operation. It is also advisable to retain data on the erasure endurance of each block and limit the number of erase operations to a certain number.
4. If an error occurs during block erase, attempt to execute the clear status register command, then execute the block erase command at least three times until the erase error does not occur.
5. Customers desiring program/erase failure rate information should contact their Renesas technical support representative.
6. The data hold time includes time that the power supply is off or the clock is not supplied.

**Table 5.7 Flash Memory (Data flash Block A to Block D) Characteristics**  
**(VCC = 2.7 to 5.5 V and T<sub>opr</sub> = -20 to 85°C (N version) / -40 to 85°C (D version), unless otherwise specified.)**

Symbol	Parameter	Conditions	Standard			Unit
			Min.	Typ.	Max.	
—	Program/erase endurance (1)		10,000 (2)	—	—	times
—	Byte program time (program/erase endurance ≤ 1,000 times)		—	160	1500	μs
—	Byte program time (program/erase endurance > 1,000 times)		—	300	1500	μs
—	Block erase time (program/erase endurance ≤ 1,000 times)		—	0.2	1	s
—	Block erase time (program/erase endurance > 1,000 times)		—	0.3	1	s
t <sub>d</sub> (SR-SUS)	Time delay from suspend request until suspend		—	—	5 + CPU clock × 3 cycles	ms
—	Interval from erase start/restart until following suspend request		0	—	—	ms
—	Time from suspend until erase restart		—	—	30+CPU clock × 1 cycle	μs
t <sub>d</sub> (CMDRST-READY)	Time from when command is forcibly terminated until reading is enabled		—	—	30+CPU clock × 1 cycle	μs
—	Program, erase voltage		2.7	—	5.5	V
—	Read voltage		1.8	—	5.5	V
—	Program, erase temperature		-20 (6)	—	85	°C
—	Data hold time (7)	Ambient temperature = 55 °C	20	—	—	year

## Notes:

- Definition of programming/erasure endurance  
The programming and erasure endurance is defined on a per-block basis.  
If the programming and erasure endurance is n (n = 10,000), each block can be erased n times. For example, if 1,024 1-byte writes are performed to different addresses in block A, a 1 Kbyte block, and then the block is erased, the programming/erasure endurance still stands at one.  
However, the same address must not be programmed more than once per erase operation (overwriting prohibited).
- Endurance to guarantee all electrical characteristics after program and erase. (1 to Min. value can be guaranteed).
- In a system that executes multiple programming operations, the actual erasure count can be reduced by writing to sequential addresses in turn so that as much of the block as possible is used up before performing an erase operation. For example, when programming groups of 16 bytes, the effective number of rewrites can be minimized by programming up to 128 groups before erasing them all in one operation. In addition, averaging the erasure endurance between blocks A to D can further reduce the actual erasure endurance. It is also advisable to retain data on the erasure endurance of each block and limit the number of erase operations to a certain number.
- If an error occurs during block erase, attempt to execute the clear status register command, then execute the block erase command at least three times until the erase error does not occur.
- Customers desiring program/erase failure rate information should contact their Renesas technical support representative.
- 40°C for D version.
- The data hold time includes time that the power supply is off or the clock is not supplied.



**Figure 5.2 Time delay until Suspend**

**Table 5.8 Voltage Detection 0 Circuit Characteristics**  
(V<sub>CC</sub> = 1.8 to 5.5 V and T<sub>opr</sub> = -20 to 85°C (N version) / -40 to 85°C (D version), unless otherwise specified.)

Symbol	Parameter	Condition	Standard			Unit
			Min.	Typ.	Max.	
V <sub>det0</sub>	Voltage detection level V <sub>det0_0</sub> (1)		1.80	1.90	2.05	V
	Voltage detection level V <sub>det0_1</sub> (1)		2.15	2.35	2.50	V
	Voltage detection level V <sub>det0_2</sub> (1)		2.70	2.85	3.05	V
	Voltage detection level V <sub>det0_3</sub> (1)		3.55	3.80	4.05	V
—	Voltage detection 0 circuit response time (3)	At the falling of V <sub>CC</sub> from 5 V to (V <sub>det0_0</sub> - 0.1) V	—	6	150	μs
—	Voltage detection circuit self power consumption	VCA25 = 1, V <sub>CC</sub> = 5.0 V	—	1.5	—	μA
t <sub>d(E-A)</sub>	Waiting time until voltage detection circuit operation starts (2)		—	—	100	μs

Notes:

1. Select the voltage detection level with bits VDSEL0 and VDSEL1 in the OFS register.
2. Necessary time until the voltage detection circuit operates when setting to 1 again after setting the VCA25 bit in the VCA2 register to 0.
3. Time until the voltage monitor 0 reset is generated after the voltage passes V<sub>det0</sub>.

**Table 5.9 Voltage Detection 1 Circuit Characteristics**  
(V<sub>CC</sub> = 1.8 to 5.5 V and T<sub>opr</sub> = -20 to 85°C (N version) / -40 to 85°C (D version), unless otherwise specified.)

Symbol	Parameter	Condition	Standard			Unit
			Min.	Typ.	Max.	
V <sub>det1</sub>	Voltage detection level V <sub>det1_0</sub> (1)	At the falling of V <sub>CC</sub>	2.00	2.20	2.40	V
	Voltage detection level V <sub>det1_1</sub> (1)	At the falling of V <sub>CC</sub>	2.15	2.35	2.55	V
	Voltage detection level V <sub>det1_2</sub> (1)	At the falling of V <sub>CC</sub>	2.30	2.50	2.70	V
	Voltage detection level V <sub>det1_3</sub> (1)	At the falling of V <sub>CC</sub>	2.45	2.65	2.85	V
	Voltage detection level V <sub>det1_4</sub> (1)	At the falling of V <sub>CC</sub>	2.60	2.80	3.00	V
	Voltage detection level V <sub>det1_5</sub> (1)	At the falling of V <sub>CC</sub>	2.75	2.95	3.15	V
	Voltage detection level V <sub>det1_6</sub> (1)	At the falling of V <sub>CC</sub>	2.85	3.10	3.40	V
	Voltage detection level V <sub>det1_7</sub> (1)	At the falling of V <sub>CC</sub>	3.00	3.25	3.55	V
	Voltage detection level V <sub>det1_8</sub> (1)	At the falling of V <sub>CC</sub>	3.15	3.40	3.70	V
	Voltage detection level V <sub>det1_9</sub> (1)	At the falling of V <sub>CC</sub>	3.30	3.55	3.85	V
	Voltage detection level V <sub>det1_A</sub> (1)	At the falling of V <sub>CC</sub>	3.45	3.70	4.00	V
	Voltage detection level V <sub>det1_B</sub> (1)	At the falling of V <sub>CC</sub>	3.60	3.85	4.15	V
	Voltage detection level V <sub>det1_C</sub> (1)	At the falling of V <sub>CC</sub>	3.75	4.00	4.30	V
	Voltage detection level V <sub>det1_D</sub> (1)	At the falling of V <sub>CC</sub>	3.90	4.15	4.45	V
	Voltage detection level V <sub>det1_E</sub> (1)	At the falling of V <sub>CC</sub>	4.05	4.30	4.60	V
	Voltage detection level V <sub>det1_F</sub> (1)	At the falling of V <sub>CC</sub>	4.20	4.45	4.75	V
—	Hysteresis width at the rising of V <sub>CC</sub> in voltage detection 1 circuit	V <sub>det1_0</sub> to V <sub>det1_5</sub> selected	—	0.07	—	V
		V <sub>det1_6</sub> to V <sub>det1_F</sub> selected	—	0.10	—	V
—	Voltage detection 1 circuit response time (2)	At the falling of V <sub>CC</sub> from 5 V to (V <sub>det1_0</sub> - 0.1) V	—	60	150	μs
—	Voltage detection circuit self power consumption	VCA26 = 1, V <sub>CC</sub> = 5.0 V	—	1.7	—	μA
t <sub>d(E-A)</sub>	Waiting time until voltage detection circuit operation starts (3)		—	—	100	μs

Notes:

1. Select the voltage detection level with bits VD1S0 to VD1S3 in the VD1LS register.
2. Time until the voltage monitor 1 interrupt request is generated after the voltage passes V<sub>det1</sub>.
3. Necessary time until the voltage detection circuit operates when setting to 1 again after setting the VCA26 bit in the VCA2 register to 0.

**Table 5.10 Voltage Detection 2 Circuit Characteristics**  
( $V_{CC} = 1.8$  to  $5.5$  V and  $T_{opr} = -20$  to  $85^{\circ}\text{C}$  (N version) /  $-40$  to  $85^{\circ}\text{C}$  (D version), unless otherwise specified.)

Symbol	Parameter	Condition	Standard			Unit
			Min.	Typ.	Max.	
$V_{det2}$	Voltage detection level $V_{det2\_0}$	At the falling of $V_{CC}$	3.70	4.00	4.30	V
—	Hysteresis width at the rising of $V_{CC}$ in voltage detection 2 circuit		—	0.10	—	V
—	Voltage detection 2 circuit response time <sup>(1)</sup>	At the falling of $V_{CC}$ from 5 V to $(V_{det2\_0} - 0.1)$ V	—	20	150	$\mu\text{s}$
—	Voltage detection circuit self power consumption	$V_{CA27} = 1$ , $V_{CC} = 5.0$ V	—	1.7	—	$\mu\text{A}$
$t_{d(E-A)}$	Waiting time until voltage detection circuit operation starts <sup>(2)</sup>		—	—	100	$\mu\text{s}$

Notes:

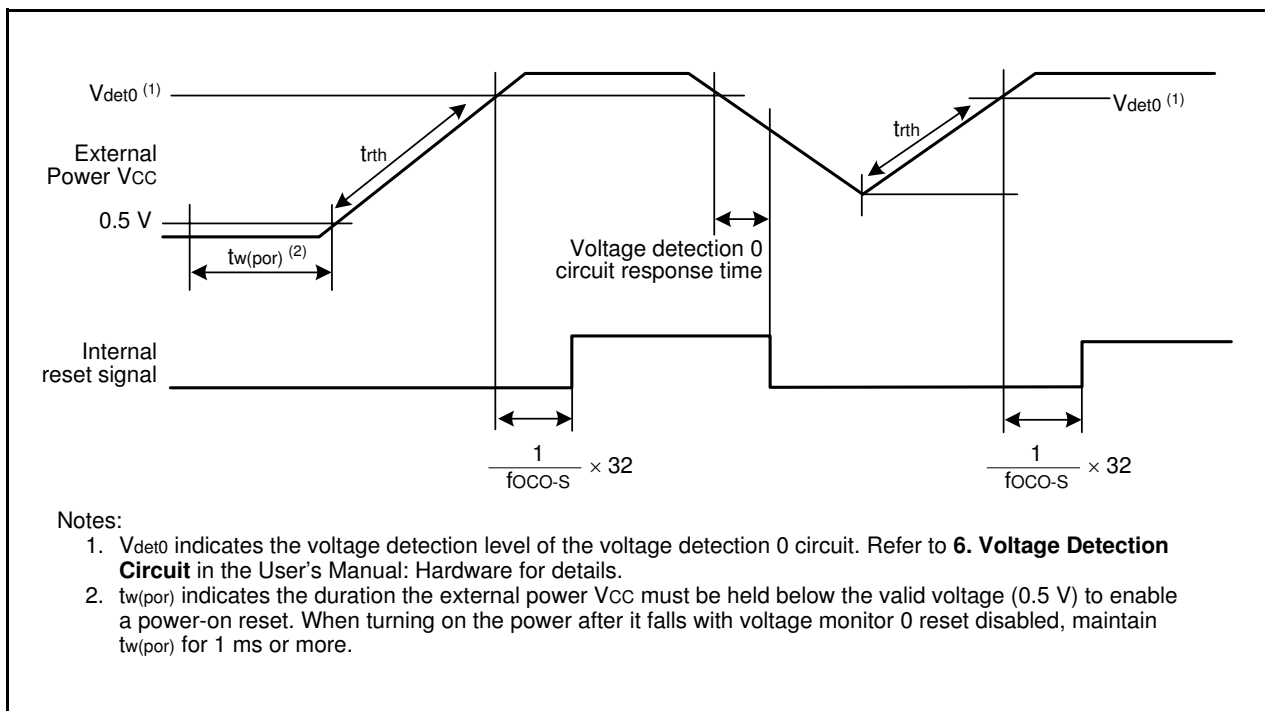
1. Time until the voltage monitor 2 interrupt request is generated after the voltage passes  $V_{det2}$ .
2. Necessary time until the voltage detection circuit operates after setting to 1 again after setting the  $V_{CA27}$  bit in the  $V_{CA2}$  register to 0.

**Table 5.11 Power-on Reset Circuit Characteristics <sup>(1)</sup>**  
( $T_{opr} = -20$  to  $85^{\circ}\text{C}$  (N version) /  $-40$  to  $85^{\circ}\text{C}$  (D version), unless otherwise specified.)

Symbol	Parameter	Condition	Standard			Unit
			Min.	Typ.	Max.	
$t_{rth}$	External power $V_{CC}$ rise gradient		0	—	50000	mV/msec

Note:

1. To use the power-on reset function, enable voltage monitor 0 reset by setting the  $LVDAS$  bit in the  $OFS$  register to 0.



**Figure 5.3 Power-on Reset Circuit Characteristics**

**Table 5.12 High-speed On-Chip Oscillator Circuit Characteristics**  
( $V_{CC} = 1.8$  to  $5.5$  V and  $T_{opr} = -20$  to  $85^{\circ}\text{C}$  (N version) /  $-40$  to  $85^{\circ}\text{C}$  (D version), unless otherwise specified.)

Symbol	Parameter	Condition	Standard			Unit
			Min.	Typ.	Max.	
—	High-speed on-chip oscillator frequency after reset	$V_{CC} = 1.8$ V to $5.5$ V $-20^{\circ}\text{C} \leq T_{opr} \leq 85^{\circ}\text{C}$	38.4	40	41.6	MHz
		$V_{CC} = 1.8$ V to $5.5$ V $-40^{\circ}\text{C} \leq T_{opr} \leq 85^{\circ}\text{C}$	38.0	40	42.0	MHz
—	High-speed on-chip oscillator frequency when the FRA4 register correction value is written into the FRA1 register and the FRA5 register correction value into the FRA3 register <sup>(1)</sup>	$V_{CC} = 1.8$ V to $5.5$ V $-20^{\circ}\text{C} \leq T_{opr} \leq 85^{\circ}\text{C}$	35.389	36.864	38.338	MHz
		$V_{CC} = 1.8$ V to $5.5$ V $-40^{\circ}\text{C} \leq T_{opr} \leq 85^{\circ}\text{C}$	35.020	36.864	38.707	MHz
—	High-speed on-chip oscillator frequency when the FRA6 register correction value is written into the FRA1 register and the FRA7 register correction value into the FRA3 register	$V_{CC} = 1.8$ V to $5.5$ V $-20^{\circ}\text{C} \leq T_{opr} \leq 85^{\circ}\text{C}$	30.72	32	33.28	MHz
		$V_{CC} = 1.8$ V to $5.5$ V $-40^{\circ}\text{C} \leq T_{opr} \leq 85^{\circ}\text{C}$	30.40	32	33.60	MHz
—	Oscillation stability time	$V_{CC} = 5.0$ V, $T_{opr} = 25^{\circ}\text{C}$	—	0.5	3	ms
—	Self power consumption at oscillation	$V_{CC} = 5.0$ V, $T_{opr} = 25^{\circ}\text{C}$	—	400	—	$\mu\text{A}$

Note:

1. This enables the setting errors of bit rates such as 9600 bps and 38400 bps to be 0% when the serial interface is used in UART mode.

**Table 5.13 Low-speed On-Chip Oscillator Circuit Characteristics**  
( $V_{CC} = 1.8$  to  $5.5$  V and  $T_{opr} = -20$  to  $85^{\circ}\text{C}$  (N version) /  $-40$  to  $85^{\circ}\text{C}$  (D version), unless otherwise specified.)

Symbol	Parameter	Condition	Standard			Unit
			Min.	Typ.	Max.	
fOCO-S	Low-speed on-chip oscillator frequency		112.5	125	137.5	kHz
—	Oscillation stability time	$V_{CC} = 5.0$ V, $T_{opr} = 25^{\circ}\text{C}$	—	30	100	$\mu\text{s}$
—	Self power consumption at oscillation	$V_{CC} = 5.0$ V, $T_{opr} = 25^{\circ}\text{C}$	—	3	—	$\mu\text{A}$
fOCO-WDT	Low-speed on-chip oscillator frequency for the watchdog timer		60	125	250	kHz
—	Oscillation stability time	$V_{CC} = 5.0$ V, $T_{opr} = 25^{\circ}\text{C}$	—	30	100	$\mu\text{s}$
—	Self power consumption at oscillation	$V_{CC} = 5.0$ V, $T_{opr} = 25^{\circ}\text{C}$	—	2	—	$\mu\text{A}$

**Table 5.14 Power Supply Circuit Characteristics**  
( $V_{CC} = 1.8$  to  $5.5$  V,  $V_{SS} = 0$  V, and  $T_{opr} = 25^{\circ}\text{C}$ , unless otherwise specified.)

Symbol	Parameter	Condition	Standard			Unit
			Min.	Typ.	Max.	
t <sub>d</sub> (P-R)	Time for internal power supply stabilization during power-on <sup>(1)</sup>		—	—	2000	$\mu\text{s}$

Note:

1. Waiting time until the internal power supply generation circuit stabilizes during power-on.

**Table 5.15 LCD Drive Control Circuit Characteristics**  
**(V<sub>CC</sub> = 1.8 to 5.5 V, V<sub>SS</sub> = 0 V, and T<sub>opr</sub> = -20 to 85°C (N version) / -40 to 85°C**  
**(D version), unless otherwise specified.)**

Symbol	Parameter	Condition	Standard			Unit
			Min.	Typ.	Max.	
VLCD	LCD power supply voltage	VLCD = VL4	2.2	—	5.5	V
VL3	VL3 voltage		VL2	—	VL4	V
VL2	VL2 voltage	R8C/L35C	VL1	—	VL4	V
		R8C/L36C, R8C/L38C, R8C/L3AC	VL1	—	VL3	V
VL1	VL1 voltage		1	—	VL2 (3)	V
—	VL1 internally-generated voltage accuracy (1)		Setting voltage -0.2	Setting voltage	Setting voltage +0.2	V
f(FR)	Frame frequency		50	—	180	Hz
ILCD	LCD drive control circuit current		—	(Note 2)	—	μA

Notes:

1. The voltage is selected with bits LVLS0 to LVLS3 in the LCR1 register.
2. Refer to **Table 5.18 DC Characteristics (2)**, **Table 5.20 DC Characteristics (4)**, and **Table 5.22 DC Characteristics (6)**.
3. The VL1 voltage should be VCC or below.

**Table 5.16 Power-Off Mode Characteristics**  
**(V<sub>CC</sub> = 2.2 to 5.5 V, V<sub>SS</sub> = 0 V, and T<sub>opr</sub> = -20 to 85°C (N version) / -40 to 85°C**  
**(D version), unless otherwise specified.)**

Symbol	Parameter	Condition	Standard			Unit
			Min.	Typ.	Max.	
—	Power-off mode operating supply voltage		2.2	—	5.5	V

## 5.4 DC Characteristics

**Table 5.17 DC Characteristics (1) [4.0 V ≤ V<sub>CC</sub> ≤ 5.5 V]**  
(T<sub>opr</sub> = -20 to 85°C (N version) / -40 to 85°C (D version), unless otherwise specified.)

Symbol	Parameter		Condition		Standard			Unit
					Min.	Typ.	Max.	
V <sub>OH</sub>	Output "H" voltage	Port P10, P11 (1)	V <sub>CC</sub> = 5V	I <sub>OH</sub> = -20 mA	V <sub>CC</sub> - 2.0	—	V <sub>CC</sub>	V
		Other pins	V <sub>CC</sub> = 5V	I <sub>OH</sub> = -5 mA	V <sub>CC</sub> - 2.0	—	V <sub>CC</sub>	V
		XOUT	V <sub>CC</sub> = 5V	I <sub>OH</sub> = -200 μA	1.0	—	—	V
V <sub>OL</sub>	Output "L" voltage	Port P10, P11 (1)	V <sub>CC</sub> = 5V	I <sub>OL</sub> = 20 mA	—	—	2.0	V
		Other pins	V <sub>CC</sub> = 5V	I <sub>OL</sub> = 5 mA	—	—	2.0	V
		XOUT	V <sub>CC</sub> = 5V	I <sub>OL</sub> = 200 μA	—	—	0.5	V
V <sub>T+</sub> -V <sub>T-</sub>	Hysteresis	$\overline{\text{INT0}}, \overline{\text{INT1}}, \overline{\text{INT2}},$ $\overline{\text{INT3}}, \overline{\text{INT4}}, \overline{\text{INT5}},$ $\overline{\text{INT6}}, \overline{\text{INT7}},$ $\overline{\text{KI0}}, \overline{\text{KI1}}, \overline{\text{KI2}}, \overline{\text{KI3}},$ $\overline{\text{KI4}}, \overline{\text{KI5}}, \overline{\text{KI6}}, \overline{\text{KI7}},$ TRAIO, TRCIOA, TRCIOB, TRCIOC, TRCIOD, TRDIOA0, TRDIOB0, TRDIOC0, TRDIOD0, TRDIOA1, TRDIOB1, TRDIOC1, TRDIOD1, TRCTRG, TRCCLK, TRGCLKA, TRGCLKB, TRGIOA, TRGIOB, ADTRG, RXD0, RXD1, RXD2, CLK0, CLK1, CLK2, SSI, SCL, SDA, SSO $\overline{\text{RESET}}, \overline{\text{WKUP0}}$			0.05	0.5	—	V
					0.1	1.0	—	V
I <sub>IH</sub>	Input "H" current		V <sub>I</sub> = 5.0 V, V <sub>CC</sub> = 5.0 V		—	—	5.0	μA
I <sub>IL</sub>	Input "L" current		V <sub>I</sub> = 0 V, V <sub>CC</sub> = 5.0 V		—	—	-5.0	μA
R <sub>PULLUP</sub>	Pull-up resistance		V <sub>I</sub> = 0 V, V <sub>CC</sub> = 5.0 V		25	50	100	kΩ
R <sub>IXIN</sub>	Feedback resistance	XIN			—	0.3	—	MΩ
R <sub>IXCIN</sub>	Feedback resistance	XCIN			—	14	—	MΩ
V <sub>RAM</sub>	RAM hold voltage		During stop mode		1.8	—	—	V

Note:

1. This applies when the drive capacity of the output transistor is set to High by registers P10DRR and P11DRR. When the drive capacity is set to Low, the value of any other pin applies.



**Table 5.18 DC Characteristics (2) [4.0 V ≤ Vcc ≤ 5.5 V]  
(Topr = -20 to 85°C (N version) / -40 to 85°C (D version), unless otherwise specified.)**

Symbol	Parameter		Condition						Standard			Unit	
			Oscillation Circuit		On-Chip Oscillator		CPU Clock	Low-Power-Consumption Setting	Other	Min.	Typ. <sup>(3)</sup>		Max.
			XIN <sup>(2)</sup>	XCIN	High-Speed (fOCO-F)	Low-Speed							
Icc	Power supply current <sup>(1)</sup>	High-speed clock mode	20 MHz	Off	Off	125 kHz	No division	—		—	7.0	15	mA
			16 MHz	Off	Off	125 kHz	No division	—		—	5.6	12.5	mA
			10 MHz	Off	Off	125 kHz	No division	—		—	3.6	—	mA
			20 MHz	Off	Off	125 kHz	Divide-by-8	—		—	3.0	—	mA
			16 MHz	Off	Off	125 kHz	Divide-by-8	—		—	2.2	—	mA
			10 MHz	Off	Off	125 kHz	Divide-by-8	—		—	1.5	—	mA
	High-speed on-chip oscillator mode	Off	Off	20 MHz	125 kHz	No division	—		—	7.0	15	mA	
		Off	Off	20 MHz	125 kHz	Divide-by-8	—		—	3.0	—	mA	
		Off	Off	4 MHz	125 kHz	Divide-by-16	MSTIIC = 1 MSTTRD = 1 MSTTRC = 1 MSTTRG = 1		—	1	—	mA	
	Low-speed on-chip oscillator mode	Off	Off	Off	125 kHz	Divide-by-8	FMR27 = 1 VCA20 = 0		—	90	400	μA	
	Low-speed clock mode	Off	32 kHz	Off	Off	No division	FMR27 = 1 VCA20 = 0		—	100	400	μA	
		Off	32 kHz	Off	Off	No division	FMSTP = 1 VCA20 = 0	Flash memory off Program operation on RAM	—	55	—	μA	
	Wait mode	Off	Off	Off	125 kHz	—	VCA27 = 0 VCA26 = 0 VCA25 = 0 VCA20 = 1	While a WAIT instruction is executed Peripheral clock operation	—	15	100	μA	
								While a WAIT instruction is executed Peripheral clock off	—	4	90	μA	
		Off	32 kHz	Off	Off	—	VCA27 = 0 VCA26 = 0 VCA25 = 0 VCA20 = 1 CM02 = 1 CM01 = 1	While a WAIT instruction is executed Peripheral clock off	—	7	—	μA	
								While a WAIT instruction is executed Peripheral clock off Timer RE operation in real-time clock mode	—	12	—	μA	
		Off	32 kHz	Off	Off	—	VCA27 = 0 VCA26 = 0 VCA25 = 0 VCA20 = 1 CM02 = 1 CM01 = 1	While a WAIT instruction is executed Peripheral clock off Timer RE operation in real-time clock mode	—	3.5	—	μA	
	Stop mode	Off	Off	Off	Off	—	VCA27 = 0 VCA26 = 0 VCA25 = 0 CM10 = 1	Topr = 25°C Peripheral clock off	—	2.0	5.0	μA	
								Topr = 85°C Peripheral clock off	—	15	—	μA	
	Power-off mode	Off	Off	Off	Off	—	—	Topr = 25°C	—	0.02	0.2	μA	
Topr = 85°C								—	0.4	—	μA		

## Notes:

- Vcc = 4.0 V to 5.5 V, single chip mode, output pins are open, and other pins are Vss.
- XIN is set to square wave input.
- Vcc = 5.0 V
- VLCD = Vcc, external division resistors are used for VL4 to VL1, 1/3 bias, 1/4 duty, f(FR) = 64 Hz, SEG0 to SEG55 are selected, and segment and common output pins are open. The standard value does not include the current that flows through external division resistors.
- The internal voltage multiplier is used, bits LVLS3 to LVLS0 in the LCR1 register = 1011b, 1/3 bias, 1/4 duty, f(FR) = 64 Hz, SEG0 to SEG55 are selected, and segment and common output pins are open.

**Table 5.19 DC Characteristics (3) [2.7 V ≤ V<sub>CC</sub> < 4.0 V]**  
**(T<sub>opr</sub> = -20 to 85°C (N version) / -40 to 85°C (D version), unless otherwise specified.)**

Symbol	Parameter		Condition	Standard			Unit
				Min.	Typ.	Max.	
V <sub>OH</sub>	Output "H" voltage	Port P10, P11 (1)	I <sub>OH</sub> = -5 mA	V <sub>CC</sub> - 0.5	—	V <sub>CC</sub>	V
		Other pins	I <sub>OH</sub> = -1 mA	V <sub>CC</sub> - 0.5	—	V <sub>CC</sub>	V
		XOUT	I <sub>OH</sub> = -200 μA	1.0	—	—	V
V <sub>OL</sub>	Output "L" voltage	Port P10, P11 (1)	I <sub>OL</sub> = 5 mA	—	—	0.5	V
		Other pins	I <sub>OL</sub> = 1 mA	—	—	0.5	V
		XOUT	I <sub>OL</sub> = 200 μA	—	—	0.5	V
V <sub>T+</sub> -V <sub>T-</sub>	Hysteresis	$\overline{\text{INT0}}, \overline{\text{INT1}}, \overline{\text{INT2}},$ $\overline{\text{INT3}}, \overline{\text{INT4}}, \overline{\text{INT5}},$ $\overline{\text{INT6}}, \overline{\text{INT7}},$ $\overline{\text{KI0}}, \overline{\text{KI1}}, \overline{\text{KI2}}, \overline{\text{KI3}}, \overline{\text{KI4}},$ $\overline{\text{KI5}}, \overline{\text{KI6}}, \overline{\text{KI7}},$ TRAI0, TRCIOA, TRCIOB, TRCIOC, TRCIOD, TRDIOA0, TRDIOB0, TRDIOC0, TRDIOD0, TRDIOA1, TRDIOB1, TRDIOC1, TRDIOD1, TRCTRG, TRCCLK, TRGCLKA, TRGCLKB, TRGIOA, TRGIOB, ADTRG, RXD0, RXD1, RXD2, CLK0, CLK1, CLK2, SSI, SCL, SDA, SSO		0.05	0.4	—	V
		RESET, WKUP0		0.1	0.8	—	V
I <sub>IH</sub>	Input "H" current		V <sub>I</sub> = 3.0 V, V <sub>CC</sub> = 3.0 V	—	—	5.0	μA
I <sub>IL</sub>	Input "L" current		V <sub>I</sub> = 0 V, V <sub>CC</sub> = 3.0 V	—	—	-5.0	μA
R <sub>PULLUP</sub>	Pull-up resistance		V <sub>I</sub> = 0 V, V <sub>CC</sub> = 3.0 V	30	100	170	kΩ
R <sub>IXIN</sub>	Feedback resistance	XIN		—	0.3	—	MΩ
R <sub>IXCIN</sub>	Feedback resistance	XCIN		—	14	—	MΩ
V <sub>RAM</sub>	RAM hold voltage		During stop mode	1.8	—	—	V

Note:

1. This applies when the drive capacity of the output transistor is set to High by registers P10DRR and P11DRR. When the drive capacity is set to Low, the value of any other pin applies.

**Table 5.20 DC Characteristics (4) [2.7 V ≤ Vcc < 4.0 V]**  
**(Topr = −20 to 85°C (N version) / −40 to 85°C (D version), unless otherwise specified.)**

Symbol	Parameter	Condition	Condition							Standard			Unit
			Oscillation Circuit		On-Chip Oscillator		CPU Clock	Low-Power-Consumption Setting	Other	Min.	Typ. <sup>(3)</sup>	Max.	
			XIN <sup>(2)</sup>	XCIN	High-Speed (iOCO-F)	Low-Speed							
Icc	Power supply current <sup>(1)</sup>	High-speed clock mode	20 MHz	Off	Off	125 kHz	No division	—	—	7.0	14.5	mA	
			10 MHz	Off	Off	125 kHz	No division	—	—	3.6	10	mA	
			20 MHz	Off	Off	125 kHz	Divide-by-8	—	—	3.0	—	mA	
			10 MHz	Off	Off	125 kHz	Divide-by-8	—	—	1.5	—	mA	
		High-speed on-chip oscillator mode	Off	Off	20 MHz	125 kHz	No division	—	—	7.0	14.5	mA	
			Off	Off	20 MHz	125 kHz	Divide-by-8	—	—	3.0	—	mA	
			Off	Off	10 MHz	125 kHz	No division	—	—	4.0	—	mA	
			Off	Off	10 MHz	125 kHz	Divide-by-8	—	—	1.7	—	mA	
			Off	Off	4 MHz	125 kHz	Divide-by-16	MSTIIC = 1 MSTTRD = 1 MSTTRC = 1 MSTTRG = 1	—	1	—	mA	
		Low-speed on-chip oscillator mode	Off	Off	Off	125 kHz	Divide-by-8	FMR27 = 1 VCA20 = 0	—	85	390	μA	
			Off	32 kHz	Off	Off	No division	FMR27 = 1 VCA20 = 0	—	90	400	μA	
		Low-speed clock mode	Off	32 kHz	Off	Off	No division	FMSTP = 1 VCA20 = 0	Flash memory off Program operation on RAM	—	50	—	μA
	Off		32 kHz	Off	Off	No division	FMSTP = 1 VCA20 = 0	Flash memory off Program operation on RAM	—	50	—	μA	
	Wait mode	Off	Off	Off	125 kHz	—	VCA27 = 0 VCA26 = 0 VCA25 = 0 VCA20 = 1	While a WAIT instruction is executed Peripheral clock operation	—	15	90	μA	
								While a WAIT instruction is executed Peripheral clock off	—	5	80	μA	
		Off	32 kHz	Off	Off	—	VCA27 = 0 VCA26 = 0 VCA25 = 0 VCA20 = 1 CM02 = 1 CM01 = 1	While a WAIT instruction is executed Peripheral clock off Timer RE operation in real-time clock mode	—	5	—	μA	
								LCD drive control circuit <sup>(4)</sup> When external division resistors are used LCD drive control circuit <sup>(5)</sup> When the internal voltage multiplier is used	—	11	—	μA	
		Off	32 kHz	Off	Off	—	VCA27 = 0 VCA26 = 0 VCA25 = 0 VCA20 = 1 CM02 = 1 CM01 = 1	While a WAIT instruction is executed Peripheral clock off Timer RE operation in real-time clock mode	—	3.5	—	μA	
								While a WAIT instruction is executed Peripheral clock off Timer RE operation in real-time clock mode	—	3.5	—	μA	
	Stop mode	Off	Off	Off	Off	—	VCA27 = 0 VCA26 = 0 VCA25 = 0 CM10 = 1	Topr = 25°C Peripheral clock off	—	2	5.0	μA	
Topr = 85°C Peripheral clock off								—	13.0	—	μA		
Power-off mode	Off	Off	Off	Off	—	—	Topr = 25°C	—	0.02	0.2	μA		
							Topr = 85°C	—	0.3	—	μA		

## Notes:

- Vcc = 2.7 V to 4.0 V, single chip mode, output pins are open, and other pins are Vss.
- XIN is set to square wave input.
- Vcc = 3.0 V
- VLCD = Vcc, external division resistors are used for VL4 to VL1, 1/3 bias, 1/4 duty, f(FR) = 64 Hz, SEG0 to SEG55 are selected, and segment and common output pins are open. The standard value does not include the current that flows through external division resistors.
- The internal voltage multiplier is used, bits LVLS3 to LVLS0 in the LCR1 register = 1011b, 1/3 bias, 1/4 duty, f(FR) = 64 Hz, SEG0 to SEG55 are selected, and segment and common output pins are open.

**Table 5.21 DC Characteristics (5) [1.8 V ≤ V<sub>CC</sub> < 2.7 V]**  
**(T<sub>opr</sub> = -20 to 85°C (N version) / -40 to 85°C (D version), unless otherwise specified.)**

Symbol	Parameter		Condition	Standard			Unit
				Min.	Typ.	Max.	
V <sub>OH</sub>	Output "H" voltage	Port P10, P11 (1)	I <sub>OH</sub> = -2 mA	V <sub>CC</sub> - 0.5	—	V <sub>CC</sub>	V
		Other pins	I <sub>OH</sub> = -1 mA	V <sub>CC</sub> - 0.5	—	V <sub>CC</sub>	V
		XOUT	I <sub>OH</sub> = -200 μA	1.0	—	—	V
V <sub>OL</sub>	Output "L" voltage	Port P10, P11 (1)	I <sub>OL</sub> = 2 mA	—	—	0.5	V
		Other pins	I <sub>OL</sub> = 1 mA	—	—	0.5	V
		XOUT	I <sub>OL</sub> = 200 μA	—	—	0.5	V
V <sub>T+</sub> -V <sub>T-</sub>	Hysteresis	$\overline{\text{INT0}}, \overline{\text{INT1}}, \overline{\text{INT2}},$ $\overline{\text{INT3}}, \overline{\text{INT4}}, \overline{\text{INT5}},$ $\overline{\text{INT6}}, \overline{\text{INT7}},$ $\overline{\text{KI0}}, \overline{\text{KI1}}, \overline{\text{KI2}}, \overline{\text{KI3}}, \overline{\text{KI4}},$ $\overline{\text{KI5}}, \overline{\text{KI6}}, \overline{\text{KI7}},$ TRAI0, TRCIOA, TRCIOB, TRCIOC, TRCIOD, TRDIOA0, TRDIOB0, TRDIOC0, TRDIOD0, TRDIOA1, TRDIOB1, TRDIOC1, TRDIOD1, TRCTRG, TRCCLK, TRGCLKA, TRGCLKB, TRGIOA, TRGIOB, ADTRG, RXD0, RXD1, RXD2, CLK0, CLK1, CLK2, SSI, SCL, SDA, SSO		0.05	0.4	—	V
		$\overline{\text{RESET}}, \overline{\text{WKUP0}}$		0.1	0.8	—	V
I <sub>IH</sub>	Input "H" current		V <sub>I</sub> = 1.8 V, V <sub>CC</sub> = 1.8 V	—	—	4.0	μA
I <sub>IL</sub>	Input "L" current		V <sub>I</sub> = 0 V, V <sub>CC</sub> = 1.8 V	—	—	-4.0	μA
R <sub>PULLUP</sub>	Pull-up resistance		V <sub>I</sub> = 0 V, V <sub>CC</sub> = 1.8 V	60	160	420	kΩ
R <sub>IXIN</sub>	Feedback resistance	XIN		—	0.3	—	MΩ
R <sub>IXCIN</sub>	Feedback resistance	XCIN		—	14	—	MΩ
V <sub>RAM</sub>	RAM hold voltage		During stop mode	1.8	—	—	V

## Note:

1. This applies when the drive capacity of the output transistor is set to High by registers P10DRR and P11DRR. When the drive capacity is set to Low, the value of any other pin applies.

**Table 5.22 DC Characteristics (6) [1.8 V ≤ Vcc < 2.7 V]**  
**(Topt = −20 to 85°C (N version) / −40 to 85°C (D version), unless otherwise specified.)**

Symbol	Parameter	Condition								Standard			Unit	
		Oscillation Circuit		On-Chip Oscillator		CPU Clock	Low-Power-Consumption Setting	Other	Min.	Typ. <sup>(3)</sup>	Max.			
		XIN <sup>(2)</sup>	XCIN	High-Speed (iOCO-F)	Low-Speed									
Icc	Power supply current <sup>(1)</sup>	High-speed clock mode	5 MHz	Off	Off	125 kHz	No division	—		—	2.2	—	mA	
			5 MHz	Off	Off	125 kHz	Divide-by-8	—		—	0.8	—	mA	
		High-speed on-chip oscillator mode	Off	Off	5 MHz	125 kHz	No division	—		—	2.5	10	mA	
			Off	Off	5 MHz	125 kHz	Divide-by-8	—		—	1.7	—	mA	
		Low-speed on-chip oscillator mode	Off	Off	4 MHz	125 kHz	Divide-by-16	MSTIIC = 1 MSTTRD = 1 MSTTRC = 1 MSTTRG = 1		—	1	—	mA	
			Off	Off	Off	125 kHz	Divide-by-8	FMR27 = 1 VCA20 = 0		—	90	300	μA	
		Low-speed clock mode	Off	32 kHz	Off	Off	No division	FMR27 = 1 VCA20 = 0		—	90	400	μA	
			Off	32 kHz	Off	Off	No division	FMSTP = 1 VCA20 = 0	Flash memory off Program operation on RAM	—	45	—	μA	
		Wait mode	Off	Off	Off	125 kHz	—	VCA27 = 0 VCA26 = 0 VCA25 = 0 VCA20 = 1	While a WAIT instruction is executed Peripheral clock operation	—	15	90	μA	
										Off	Off	Off	125 kHz	—
			Off	32 kHz	Off	Off	—	VCA27 = 0 VCA26 = 0 VCA25 = 0 VCA20 = 1 CM02 = 1 CM01 = 0	While a WAIT instruction is executed Peripheral clock off Timer RE operation in real-time clock mode					
										Off	32 kHz	Off	Off	—
		Stop mode	Off	Off	Off	Off	—	VCA27 = 0 VCA26 = 0 VCA25 = 0 CM10 = 1	Topt = 25°C Peripheral clock off	—	2.0	5.0	μA	
										Off	Off	Off	Off	—
		Power-off mode	Off	Off	Off	Off	—	Topt = 25°C	—					
Off	Off								Off	Off	—	Topt = 85°C	—	0.3

## Notes:

- Vcc = 1.8 V to 2.7 V, single chip mode, output pins are open, and other pins are Vss.
- XIN is set to square wave input.
- Vcc = 2.2 V
- VLCD = Vcc, external division resistors are used for VL4 to VL1, 1/3 bias, 1/4 duty, f(FR) = 64 Hz, SEG0 to SEG55 are selected, and segment and common output pins are open. The standard value does not include the current that flows through external division resistors.
- The internal voltage multiplier is used, bits LVLS3 to LVLS0 in the LCR1 register = 1011b, 1/3 bias, 1/4 duty, f(FR) = 64 Hz, SEG0 to SEG55 are selected, and segment and common output pins are open.

## 5.5 AC Characteristics

**Table 5.23 Timing Requirements of Synchronous Serial Communication Unit (SSU)**  
( $V_{CC} = 1.8$  to  $5.5$  V,  $V_{SS} = 0$  V, and  $T_{opr} = -20$  to  $85^{\circ}\text{C}$  (N version) /  $-40$  to  $85^{\circ}\text{C}$  (D version), unless otherwise specified.)

Symbol	Parameter		Conditions	Standard			Unit
				Min.	Typ.	Max.	
tSUCYC	SSCK clock cycle time			4	—	—	tcyc (1)
tHI	SSCK clock "H" width			0.4	—	0.6	tsucyc
tLO	SSCK clock "L" width			0.4	—	0.6	tsucyc
tRISE	SSCK clock rising time	Master		—	—	1	tcyc (1)
		Slave		—	—	1	$\mu\text{s}$
tFALL	SSCK clock falling time	Master		—	—	1	tcyc (1)
		Slave		—	—	1	$\mu\text{s}$
tSU	SSO, SSI data input setup time			100	—	—	ns
tH	SSO, SSI data input hold time			1	—	—	tcyc (1)
tLEAD	$\overline{\text{SCS}}$ setup time	Slave		1tcyc + 50	—	—	ns
tLAG	$\overline{\text{SCS}}$ hold time	Slave		1tcyc + 50	—	—	ns
tOD	SSO, SSI data output delay time			—	—	1	tcyc (1)
tSA	SSI slave access time		$2.7\text{ V} \leq V_{CC} \leq 5.5\text{ V}$	—	—	$1.5\text{tcyc} + 100$	ns
			$1.8\text{ V} \leq V_{CC} < 2.7\text{ V}$	—	—	$1.5\text{tcyc} + 200$	ns
tOR	SSI slave out open time		$2.7\text{ V} \leq V_{CC} \leq 5.5\text{ V}$	—	—	$1.5\text{tcyc} + 100$	ns
			$1.8\text{ V} \leq V_{CC} < 2.7\text{ V}$	—	—	$1.5\text{tcyc} + 200$	ns

Note:

1.  $1\text{tcyc} = 1/f_1(\text{s})$

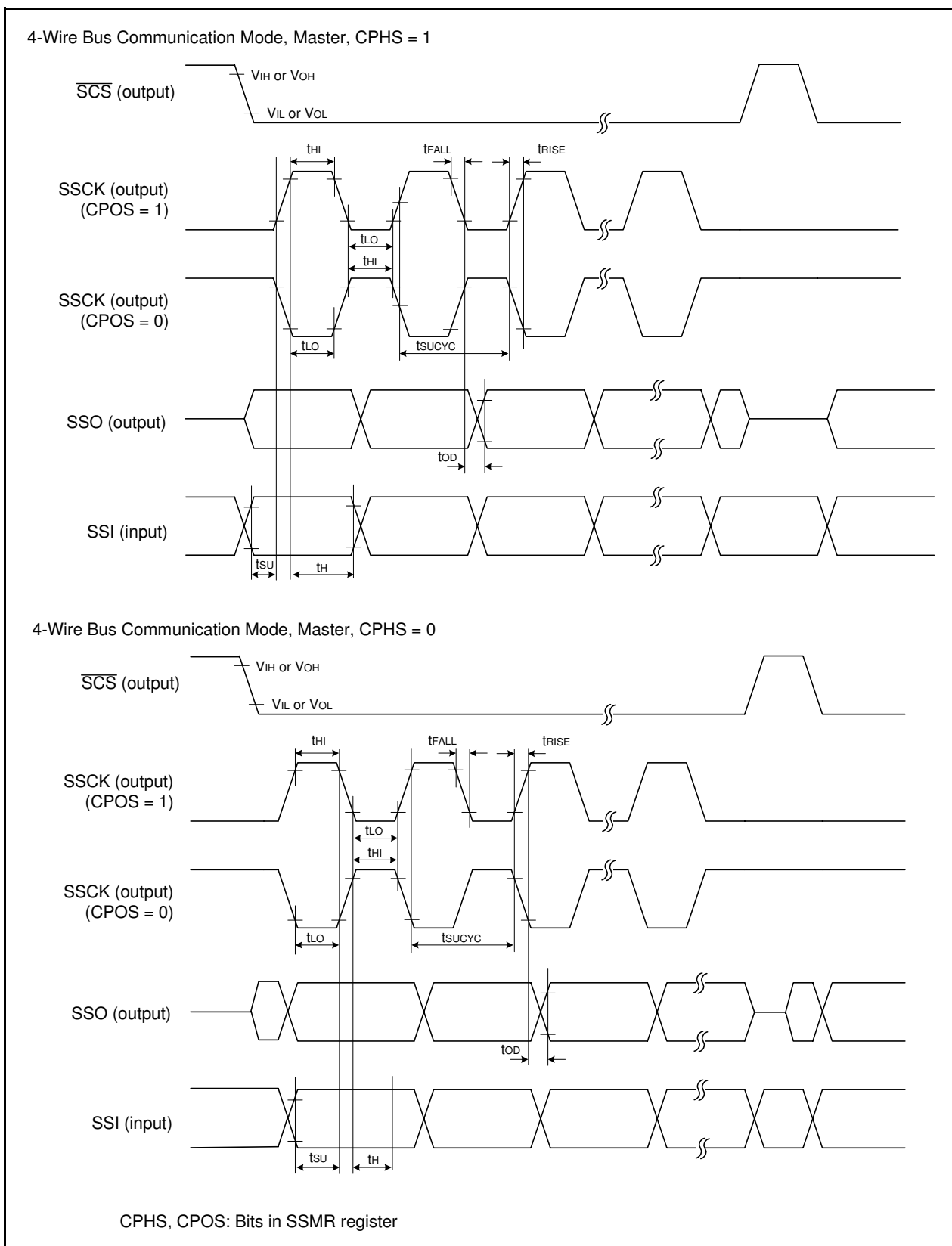


Figure 5.4 I/O Timing of Synchronous Serial Communication Unit (SSU) (Master)

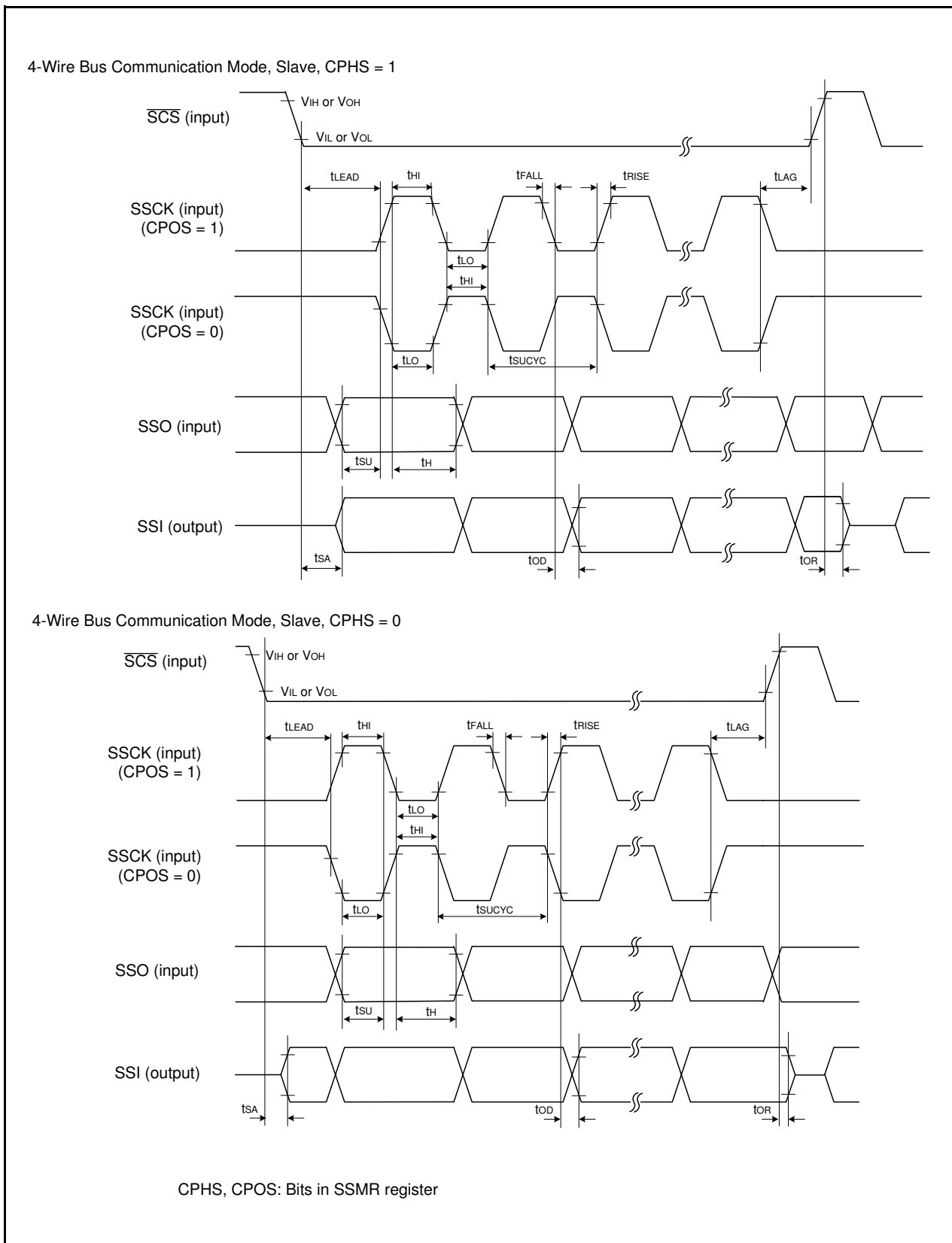
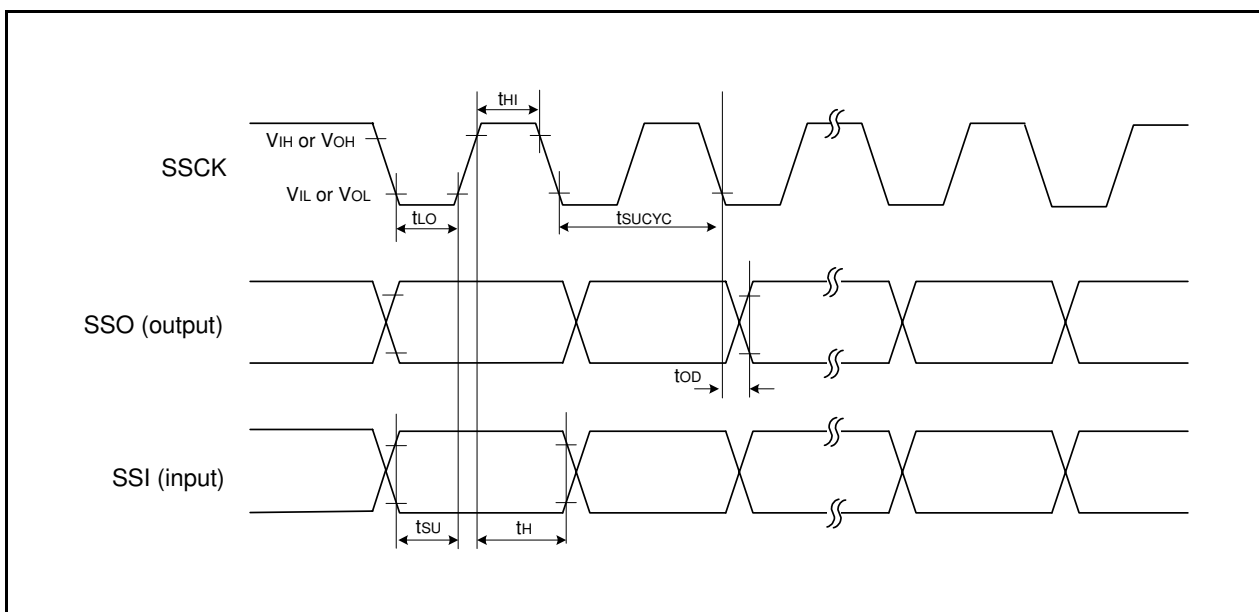


Figure 5.5 I/O Timing of Synchronous Serial Communication Unit (SSU) (Slave)





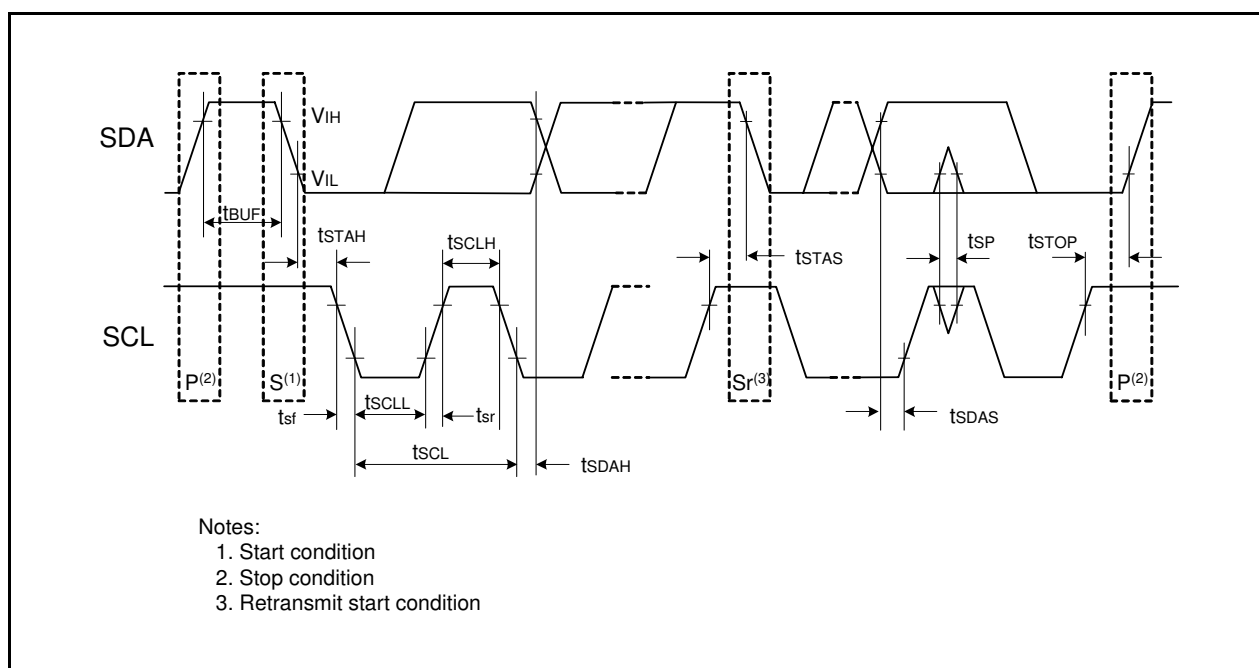
**Figure 5.6 I/O Timing of Synchronous Serial Communication Unit (SSU) (Clock Synchronous Communication Mode)**

**Table 5.24 Timing Requirements of I<sup>2</sup>C bus Interface (1)**  
**(V<sub>CC</sub> = 1.8 to 5.5 V, V<sub>SS</sub> = 0 V, and T<sub>opr</sub> = -20 to 85°C (N version) / -40 to 85°C (D version), unless otherwise specified.)**

Symbol	Parameter	Condition	Standard			Unit
			Min.	Typ.	Max.	
t <sub>SCL</sub>	SCL input cycle time		12tcyc + 600 (1)	—	—	ns
t <sub>SCLH</sub>	SCL input "H" width		3tcyc + 300 (1)	—	—	ns
t <sub>SCLL</sub>	SCL input "L" width		5tcyc + 500 (1)	—	—	ns
t <sub>sf</sub>	SCL, SDA input fall time		—	—	300	ns
t <sub>SP</sub>	SCL, SDA input spike pulse rejection time		—	—	1tcyc (1)	ns
t <sub>BUF</sub>	SDA input bus-free time		5tcyc (1)	—	—	ns
t <sub>STAH</sub>	Start condition input hold time		3tcyc (1)	—	—	ns
t <sub>STAS</sub>	Retransmit start condition input setup time		3tcyc (1)	—	—	ns
t <sub>STOP</sub>	Stop condition input setup time		3tcyc (1)	—	—	ns
t <sub>SDAS</sub>	Data input setup time		1tcyc + 40 (1)	—	—	ns
t <sub>SDAH</sub>	Data input hold time		10	—	—	ns

Note:

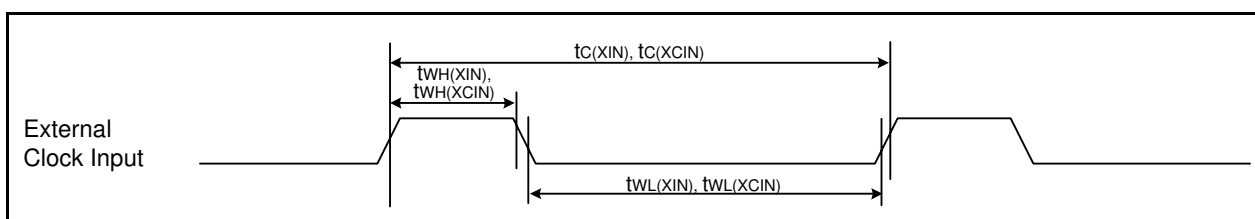
1. 1tcyc = 1/f1(s)



**Figure 5.7 I/O Timing of I<sup>2</sup>C bus Interface**

**Table 5.25 External Clock Input (XIN, XCIN)**  
( $V_{CC} = 1.8$  to  $5.5$  V,  $V_{SS} = 0$  V, and  $T_{opr} = -20$  to  $85^{\circ}\text{C}$  (N version) /  $-40$  to  $85^{\circ}\text{C}$  (D version), unless otherwise specified.)

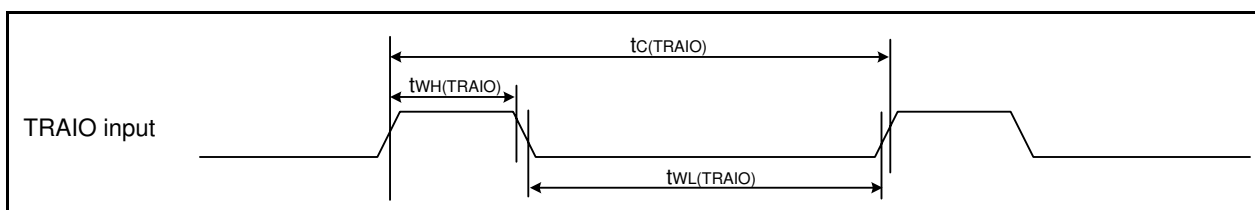
Symbol	Parameter	Standard						Unit
		$V_{CC} = 2.2\text{V}, T_{opr} = 25^{\circ}\text{C}$		$V_{CC} = 3\text{V}, T_{opr} = 25^{\circ}\text{C}$		$V_{CC} = 5\text{V}, T_{opr} = 25^{\circ}\text{C}$		
		Min.	Max.	Min.	Max.	Min.	Max.	
$t_{c(XIN)}$	XIN input cycle time	200	—	50	—	50	—	ns
$t_{WH(XIN)}$	XIN input "H" width	90	—	24	—	24	—	ns
$t_{WL(XIN)}$	XIN input "L" width	90	—	24	—	24	—	ns
$t_{c(XCIN)}$	XCIN input cycle time	14	—	14	—	14	—	$\mu\text{s}$
$t_{WH(XCIN)}$	XCIN input "H" width	7	—	7	—	7	—	$\mu\text{s}$
$t_{WL(XCIN)}$	XCIN input "L" width	7	—	7	—	7	—	$\mu\text{s}$



**Figure 5.8 External Clock Input Timing Diagram**

**Table 5.26 Timing Requirements of TRAIO**  
( $V_{CC} = 1.8$  to  $5.5$  V,  $V_{SS} = 0$  V and  $T_{opr} = -20$  to  $85^{\circ}\text{C}$  (N version) /  $-40$  to  $85^{\circ}\text{C}$  (D version), unless otherwise specified.)

Symbol	Parameter	Standard						Unit
		$V_{CC} = 2.2\text{V}, T_{opr} = 25^{\circ}\text{C}$		$V_{CC} = 3\text{V}, T_{opr} = 25^{\circ}\text{C}$		$V_{CC} = 5\text{V}, T_{opr} = 25^{\circ}\text{C}$		
		Min.	Max.	Min.	Max.	Min.	Max.	
$t_{c(TRAIO)}$	TRAIO input cycle time	500	—	300	—	100	—	ns
$t_{WH(TRAIO)}$	TRAIO input "H" width	200	—	120	—	40	—	ns
$t_{WL(TRAIO)}$	TRAIO input "L" width	200	—	120	—	40	—	ns

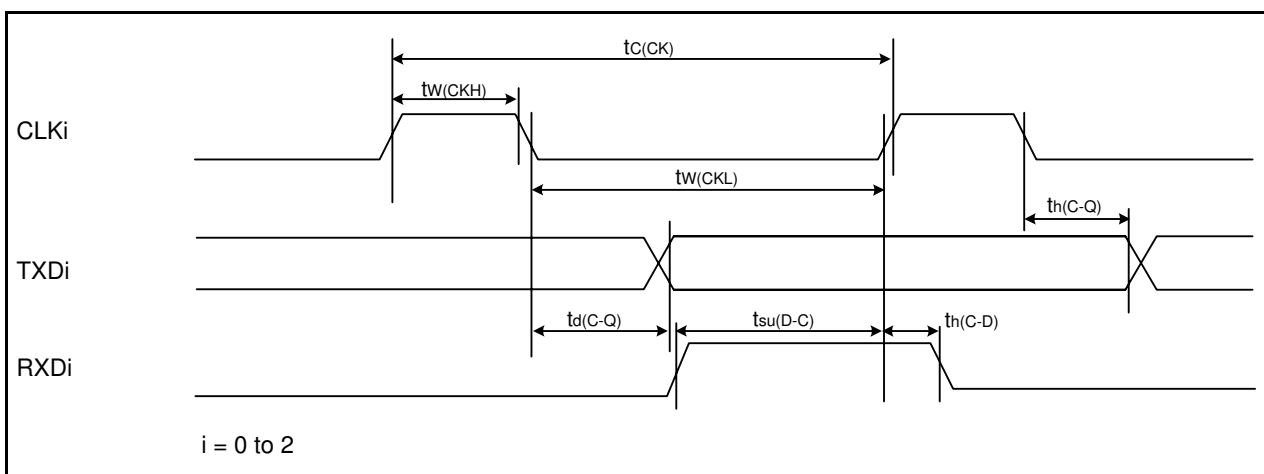


**Figure 5.9 Input Timing of TRAIO**

**Table 5.27 Timing Requirements of Serial Interface**  
( $V_{CC} = 1.8$  to  $5.5$  V,  $V_{SS} = 0$  V, and  $T_{opr} = -20$  to  $85^{\circ}\text{C}$  (N version) /  $-40$  to  $85^{\circ}\text{C}$  (D version), unless otherwise specified.)

Symbol	Parameter	Standard						Unit
		$V_{CC} = 2.2\text{V}, T_{opr} = 25^{\circ}\text{C}$		$V_{CC} = 3\text{V}, T_{opr} = 25^{\circ}\text{C}$		$V_{CC} = 5\text{V}, T_{opr} = 25^{\circ}\text{C}$		
		Min.	Max.	Min.	Max.	Min.	Max.	
$t_{c(CK)}$	CLKi input cycle time	800	—	300	—	200	—	ns
$t_{w(CKH)}$	CLKi input "H" width	400	—	150	—	100	—	ns
$t_{w(CKL)}$	CLKi input "L" width	400	—	150	—	100	—	ns
$t_{d(C-Q)}$	TXDi output delay time	—	200	—	80	—	50	ns
$t_{h(C-Q)}$	TXDi hold time	0	—	0	—	0	—	ns
$t_{su(D-C)}$	RXDi input setup time	150	—	70	—	50	—	ns
$t_{h(C-D)}$	RXDi input hold time	90	—	90	—	90	—	ns

$i = 0$  to  $2$



$i = 0$  to  $2$

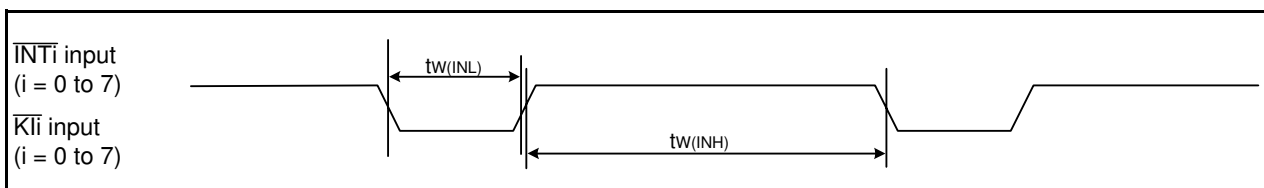
**Figure 5.10 Input and Output Timing of Serial Interface**

**Table 5.28 Timing Requirements of External Interrupt  $\overline{\text{INT}}_i$  ( $i = 0$  to  $7$ ) and Key Input Interrupt  $\overline{\text{K}}_i$  ( $i = 0$  to  $7$ )**  
( $V_{CC} = 1.8$  to  $5.5$  V,  $V_{SS} = 0$  V, and  $T_{opr} = -20$  to  $85^{\circ}\text{C}$  (N version) /  $-40$  to  $85^{\circ}\text{C}$  (D version), unless otherwise specified.)

Symbol	Parameter	Standard						Unit
		$V_{CC} = 2.2\text{V}, T_{opr} = 25^{\circ}\text{C}$		$V_{CC} = 3\text{V}, T_{opr} = 25^{\circ}\text{C}$		$V_{CC} = 5\text{V}, T_{opr} = 25^{\circ}\text{C}$		
		Min.	Max.	Min.	Max.	Min.	Max.	
$t_{w(\text{INH})}$	$\overline{\text{INT}}_i$ input "H" width, $\overline{\text{K}}_i$ input "H" width	1000 (1)	—	380 (1)	—	250 (1)	—	ns
$t_{w(\text{INL})}$	$\overline{\text{INT}}_i$ input "L" width, $\overline{\text{K}}_i$ input "L" width	1000 (2)	—	380 (2)	—	250 (2)	—	ns

Notes:

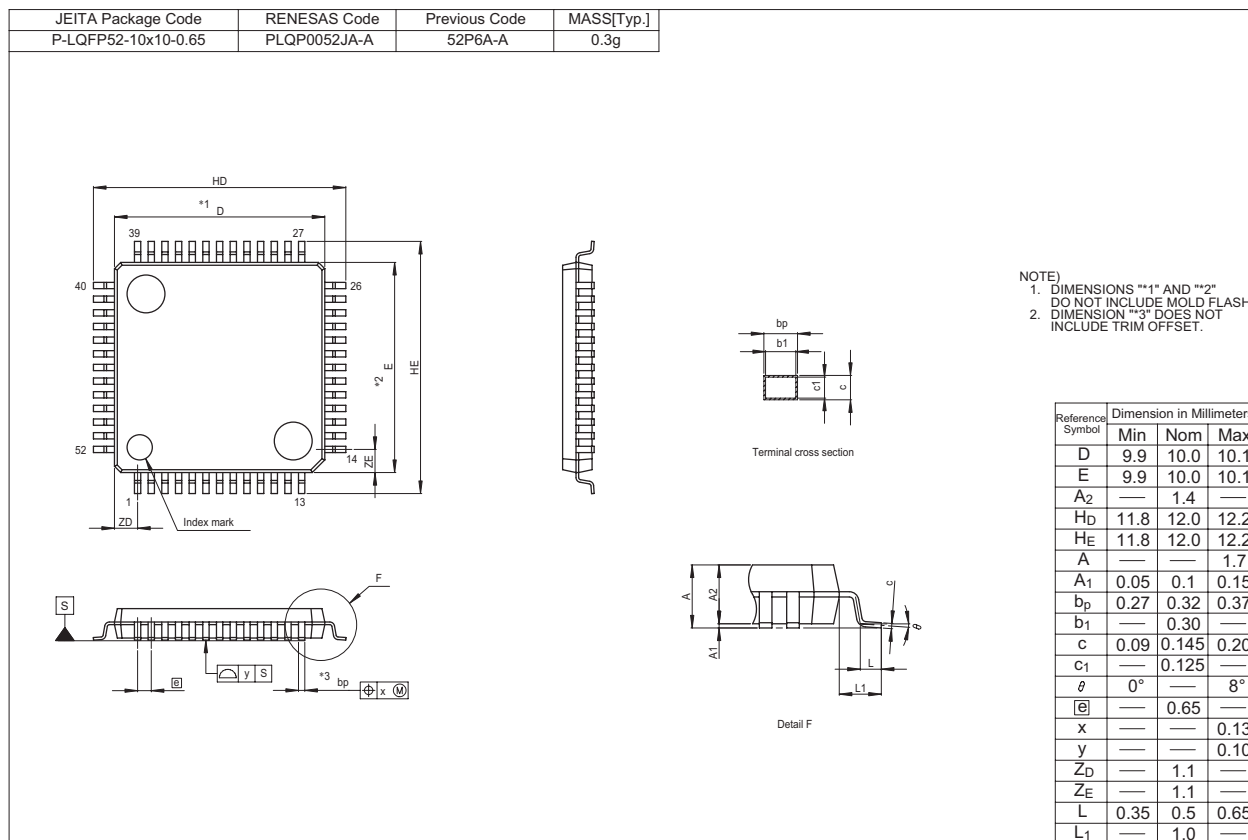
- When selecting the digital filter by the  $\overline{\text{INT}}_i$  input filter select bit, use an  $\overline{\text{INT}}_i$  input HIGH width of either (1/digital filter clock frequency  $\times$  3) or the minimum value of standard, whichever is greater.
- When selecting the digital filter by the  $\overline{\text{INT}}_i$  input filter select bit, use an  $\overline{\text{INT}}_i$  input LOW width of either (1/digital filter clock frequency  $\times$  3) or the minimum value of standard, whichever is greater.

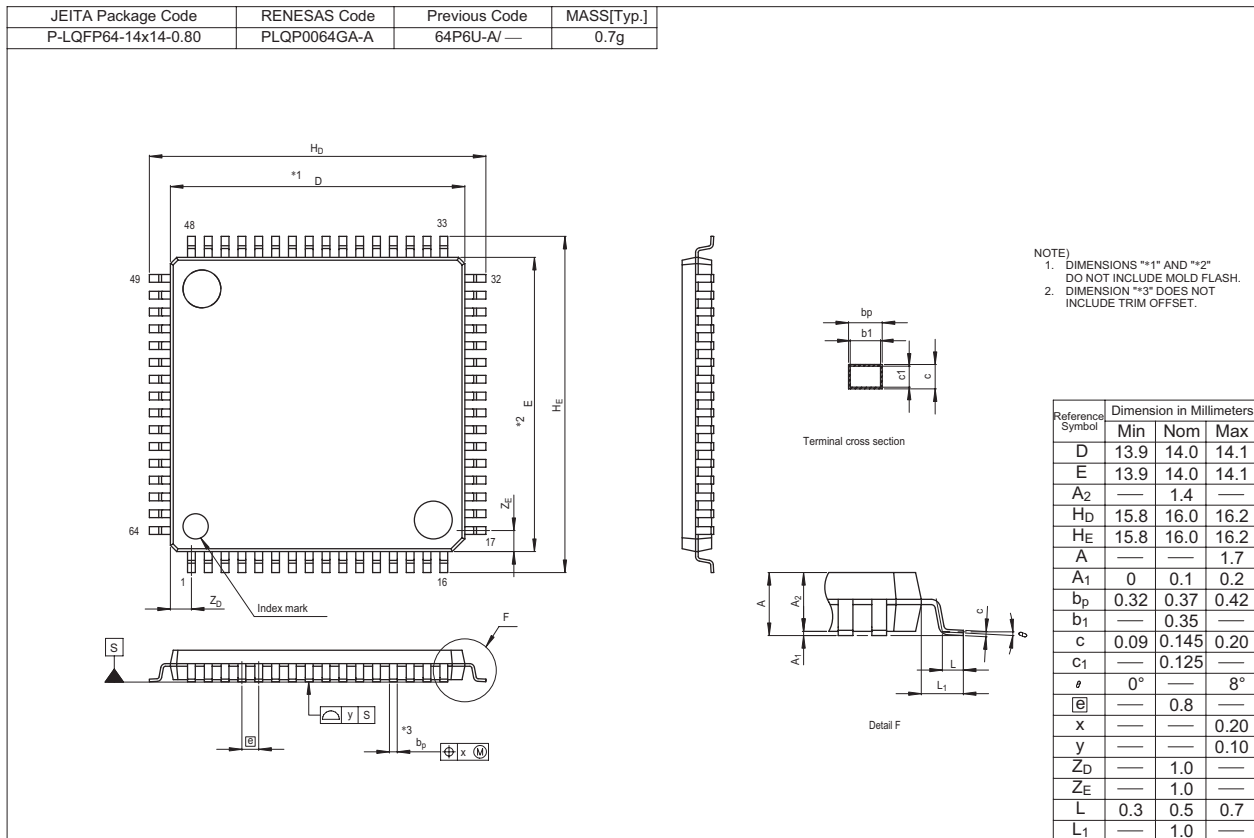
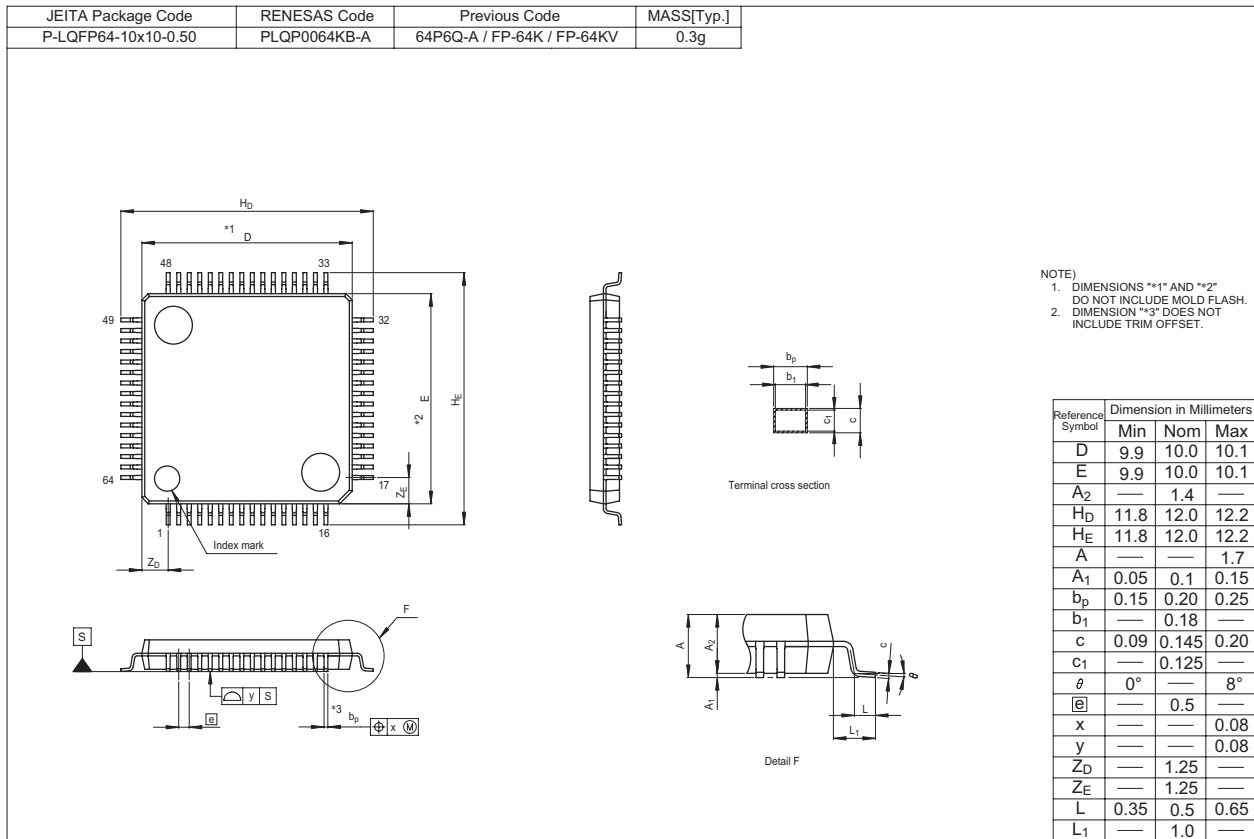


**Figure 5.11 Input Timing of External Interrupt  $\overline{\text{INT}}_i$  and Key Input Interrupt  $\overline{\text{K}}_i$**

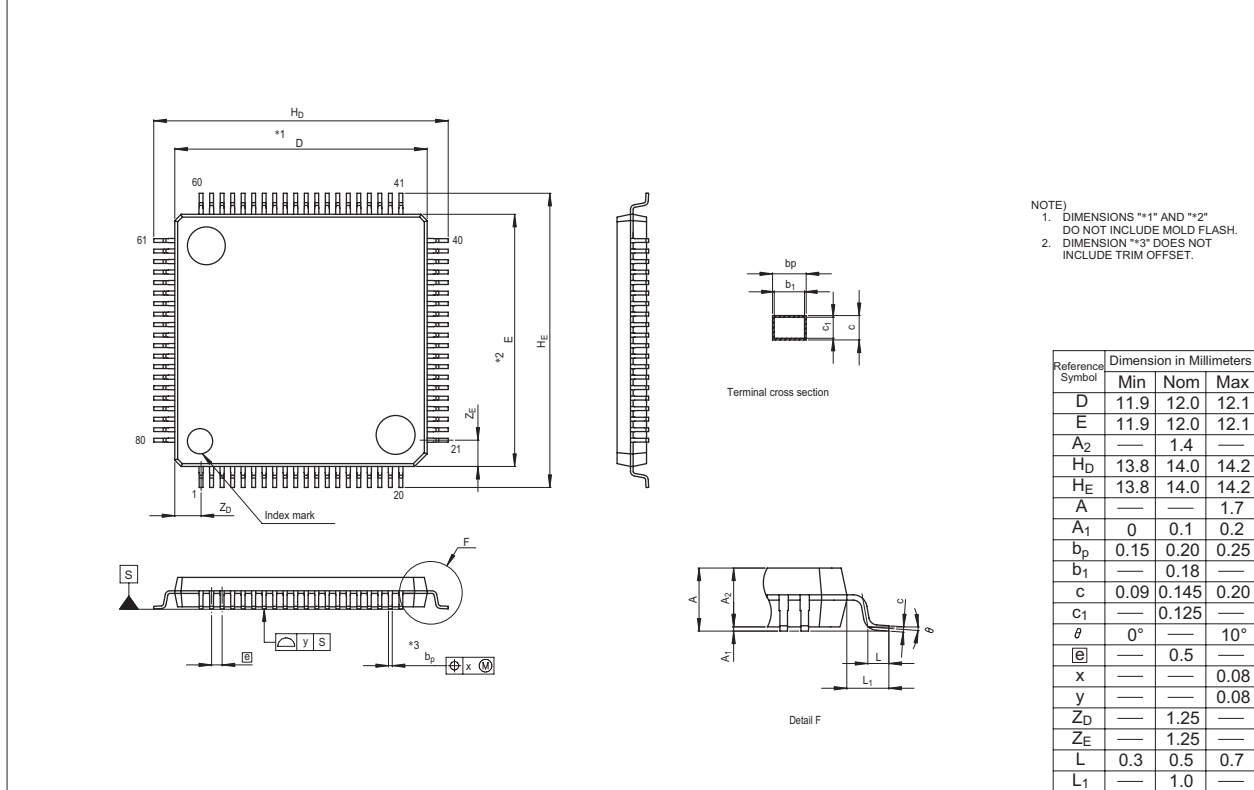
## Package Dimensions

Diagrams showing the latest package dimensions and mounting information are available in the “Packages” section of the Renesas Electronics web site.

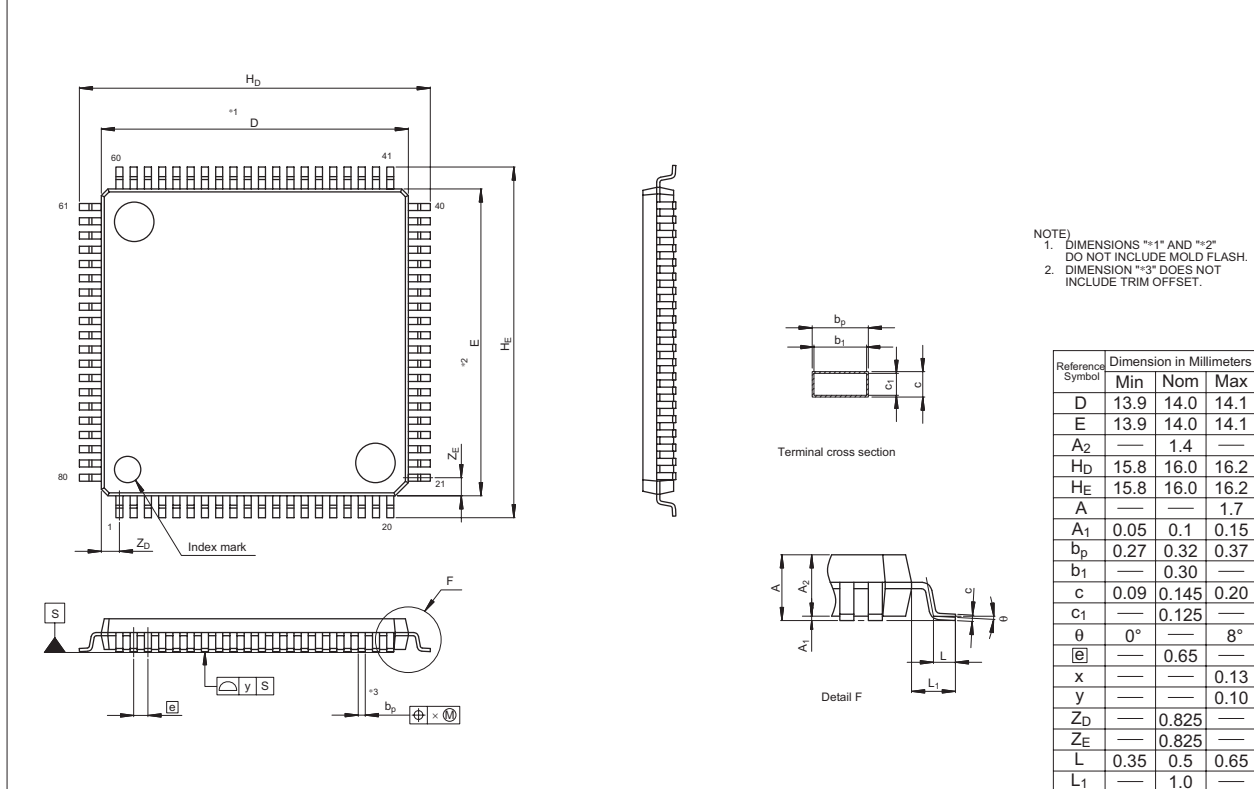


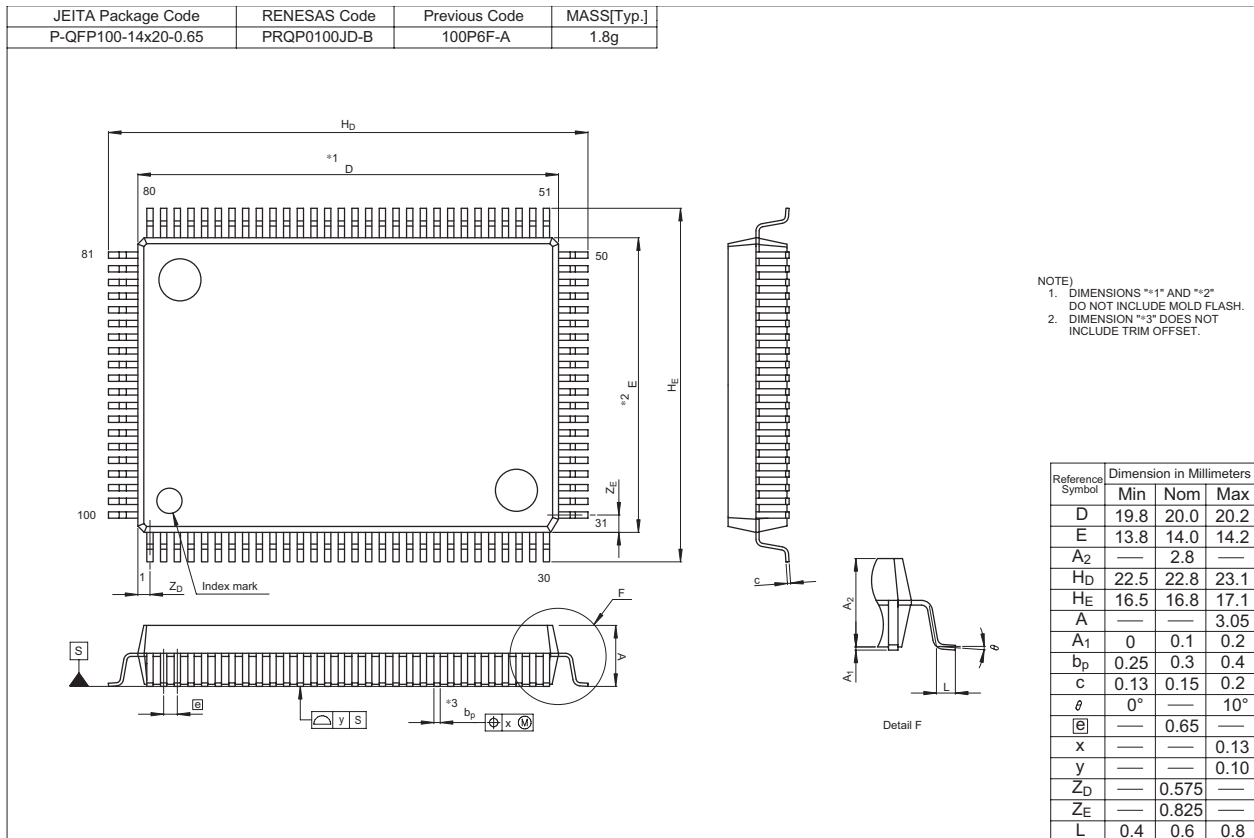
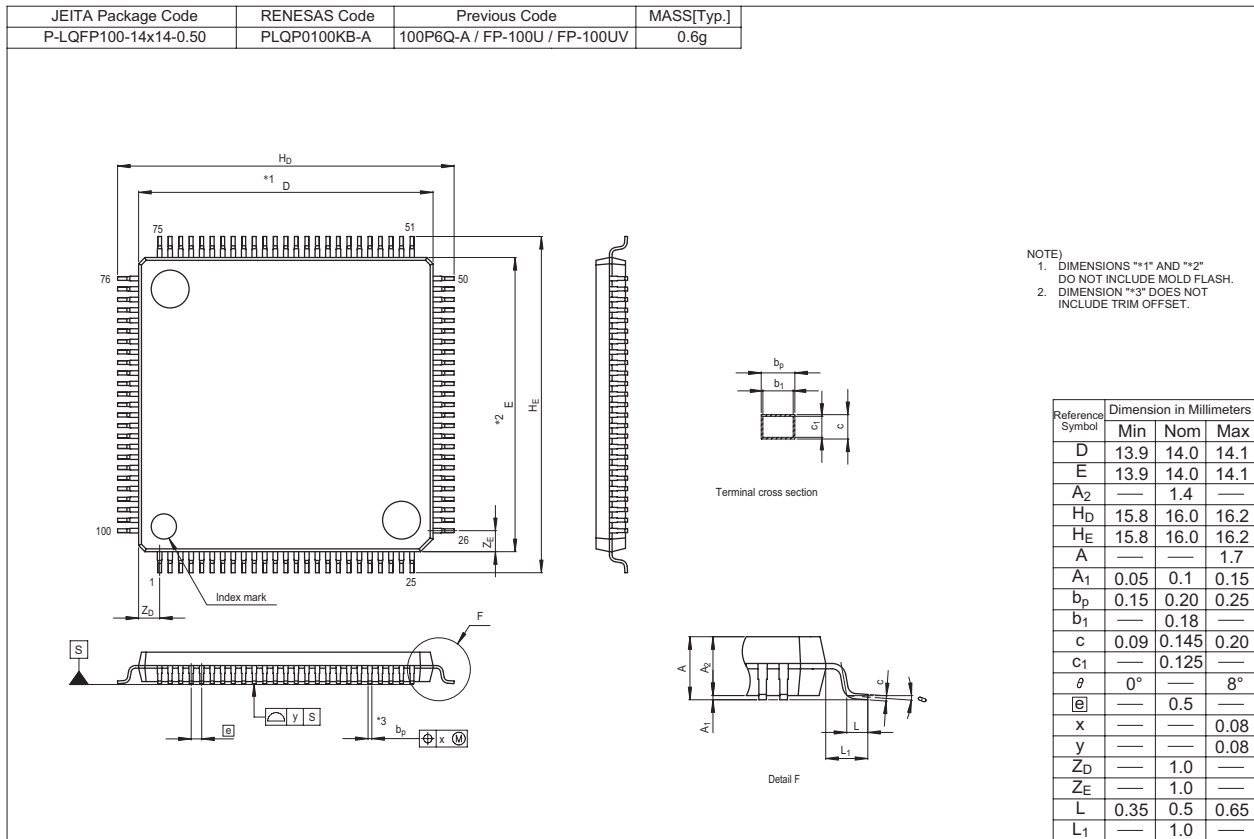


JEITA Package Code	RENESAS Code	Previous Code	MASS[Typ.]
P-LQFP80-12x12-0.50	PLQP0080KB-A	80P6Q-A	0.5g



JEITA Package Code	RENESAS Code	Previous Code	MASS[Typ.]
P-LQFP80-14x14-0.65	PLQP0080JA-A	FP-80W / FP-80WV	0.6g







## REVISION HISTORY

R8C/L35C Group, R8C/L36C Group, R8C/L38C Group, R8C/L3AC Group  
Datasheet

Rev.	Date	Description	
		Page	Summary
0.10	Oct 30, 2009	—	First Edition issued
0.20	Apr 15, 2011	6 7 7 to 10 24 29 45 to 68	Table 1.6 Function deleted, Current consumption revised 1.2 “of R8C/Lx Series” → “for Each Group” Tables 1.7 to 1.10 revised Table 1.15 “Voltage detection circuit” deleted 4. Special Function Registers (SFRs) “The description offered in this chapter is based on the R8C/L3AC Group.” added 5. Electrical Characteristics added
1.00	Jun 25, 2010	— 1 7 to 10 45 55 69 to 72	“Preliminary” and “Under development” deleted 1.1 revised Tables 1.7 to 1.10 revised Tables 5.1 Note 2 added Table 5.15 Note 3 added Package Dimensions revised
1.01	Apr 15, 2011	2 3 6 11 to 14 20 to 22 23, 24 28 38 to 40 48 57, 59, 61	Table 1.1 revised Table 1.2 Note 2, Table 1.3 Note 1 revised Table 1.6 “Flash Memory” revised Figure 1.5 to Figure 1.8 revised Table 1.11 to Table 1.13 “Voltage Detection Circuit” deleted Table 1.14 and Table 1.15 title “for R8C/L3AC Group” added 3. “The internal ROM ... with address 0FFFFh.” deleted Table 4.10 to Table 4.12 “0248h to 026Fh”, “02A8h to 02BFh”, “02C0h to 02CFh” revised Table 5.3 “tCONV”, “tSAMP” revised Table 5.18, Table 5.20, Table 5.22 “High-Speed” → “High-Speed (fOCO-F)”

All trademarks and registered trademarks are the property of their respective owners.

## General Precautions in the Handling of MPU/MCU Products

The following usage notes are applicable to all MPU/MCU products from Renesas. For detailed usage notes on the products covered by this manual, refer to the relevant sections of the manual. If the descriptions under General Precautions in the Handling of MPU/MCU Products and in the body of the manual differ from each other, the description in the body of the manual takes precedence.

### 1. Handling of Unused Pins

Handle unused pins in accord with the directions given under Handling of Unused Pins in the manual.

- The input pins of CMOS products are generally in the high-impedance state. In operation with an unused pin in the open-circuit state, extra electromagnetic noise is induced in the vicinity of LSI, an associated shoot-through current flows internally, and malfunctions occur due to the false recognition of the pin state as an input signal become possible. Unused pins should be handled as described under Handling of Unused Pins in the manual.

### 2. Processing at Power-on

The state of the product is undefined at the moment when power is supplied.

- The states of internal circuits in the LSI are indeterminate and the states of register settings and pins are undefined at the moment when power is supplied.

In a finished product where the reset signal is applied to the external reset pin, the states of pins are not guaranteed from the moment when power is supplied until the reset process is completed.

In a similar way, the states of pins in a product that is reset by an on-chip power-on reset function are not guaranteed from the moment when power is supplied until the power reaches the level at which resetting has been specified.

### 3. Prohibition of Access to Reserved Addresses

Access to reserved addresses is prohibited.

- The reserved addresses are provided for the possible future expansion of functions. Do not access these addresses; the correct operation of LSI is not guaranteed if they are accessed.

### 4. Clock Signals

After applying a reset, only release the reset line after the operating clock signal has become stable. When switching the clock signal during program execution, wait until the target clock signal has stabilized.

- When the clock signal is generated with an external resonator (or from an external oscillator) during a reset, ensure that the reset line is only released after full stabilization of the clock signal. Moreover, when switching to a clock signal produced with an external resonator (or by an external oscillator) while program execution is in progress, wait until the target clock signal is stable.

### 5. Differences between Products

Before changing from one product to another, i.e. to one with a different part number, confirm that the change will not lead to problems.

- The characteristics of MPU/MCU in the same group but having different part numbers may differ because of the differences in internal memory capacity and layout pattern. When changing to products of different part numbers, implement a system-evaluation test for each of the products.

## Notice

- All information included in this document is current as of the date this document is issued. Such information, however, is subject to change without any prior notice. Before purchasing or using any Renesas Electronics products listed herein, please confirm the latest product information with a Renesas Electronics sales office. Also, please pay regular and careful attention to additional and different information to be disclosed by Renesas Electronics such as that disclosed through our website.
- Renesas Electronics does not assume any liability for infringement of patents, copyrights, or other intellectual property rights of third parties by or arising from the use of Renesas Electronics products or technical information described in this document. No license, express, implied or otherwise, is granted hereby under any patents, copyrights or other intellectual property rights of Renesas Electronics or others.
- You should not alter, modify, copy, or otherwise misappropriate any Renesas Electronics product, whether in whole or in part.
- Descriptions of circuits, software and other related information in this document are provided only to illustrate the operation of semiconductor products and application examples. You are fully responsible for the incorporation of these circuits, software, and information in the design of your equipment. Renesas Electronics assumes no responsibility for any losses incurred by you or third parties arising from the use of these circuits, software, or information.
- When exporting the products or technology described in this document, you should comply with the applicable export control laws and regulations and follow the procedures required by such laws and regulations. You should not use Renesas Electronics products or the technology described in this document for any purpose relating to military applications or use by the military, including but not limited to the development of weapons of mass destruction. Renesas Electronics products and technology may not be used for or incorporated into any products or systems whose manufacture, use, or sale is prohibited under any applicable domestic or foreign laws or regulations.
- Renesas Electronics has used reasonable care in preparing the information included in this document, but Renesas Electronics does not warrant that such information is error free. Renesas Electronics assumes no liability whatsoever for any damages incurred by you resulting from errors in or omissions from the information included herein.
- Renesas Electronics products are classified according to the following three quality grades: "Standard", "High Quality", and "Specific". The recommended applications for each Renesas Electronics product depends on the product's quality grade, as indicated below. You must check the quality grade of each Renesas Electronics product before using it in a particular application. You may not use any Renesas Electronics product for any application categorized as "Specific" without the prior written consent of Renesas Electronics. Further, you may not use any Renesas Electronics product for any application for which it is not intended without the prior written consent of Renesas Electronics. Renesas Electronics shall not be in any way liable for any damages or losses incurred by you or third parties arising from the use of any Renesas Electronics product for an application categorized as "Specific" or for which the product is not intended where you have failed to obtain the prior written consent of Renesas Electronics. The quality grade of each Renesas Electronics product is "Standard" unless otherwise expressly specified in a Renesas Electronics data sheets or data books, etc.  
"Standard": Computers; office equipment; communications equipment; test and measurement equipment; audio and visual equipment; home electronic appliances; machine tools; personal electronic equipment; and industrial robots.  
"High Quality": Transportation equipment (automobiles, trains, ships, etc.); traffic control systems; anti-disaster systems; anti-crime systems; safety equipment; and medical equipment not specifically designed for life support.  
"Specific": Aircraft; aerospace equipment; submersible repeaters; nuclear reactor control systems; medical equipment or systems for life support (e.g. artificial life support devices or systems), surgical implantations, or healthcare intervention (e.g. excision, etc.), and any other applications or purposes that pose a direct threat to human life.
- You should use the Renesas Electronics products described in this document within the range specified by Renesas Electronics, especially with respect to the maximum rating, operating supply voltage range, movement power voltage range, heat radiation characteristics, installation and other product characteristics. Renesas Electronics shall have no liability for malfunctions or damages arising out of the use of Renesas Electronics products beyond such specified ranges.
- Although Renesas Electronics endeavors to improve the quality and reliability of its products, semiconductor products have specific characteristics such as the occurrence of failure at a certain rate and malfunctions under certain use conditions. Further, Renesas Electronics products are not subject to radiation resistance design. Please be sure to implement safety measures to guard them against the possibility of physical injury, and injury or damage caused by fire in the event of the failure of a Renesas Electronics product, such as safety design for hardware and software including but not limited to redundancy, fire control and malfunction prevention, appropriate treatment for aging degradation or any other appropriate measures. Because the evaluation of microcomputer software alone is very difficult, please evaluate the safety of the final products or system manufactured by you.
- Please contact a Renesas Electronics sales office for details as to environmental matters such as the environmental compatibility of each Renesas Electronics product. Please use Renesas Electronics products in compliance with all applicable laws and regulations that regulate the inclusion or use of controlled substances, including without limitation, the EU RoHS Directive. Renesas Electronics assumes no liability for damages or losses occurring as a result of your noncompliance with applicable laws and regulations.
- This document may not be reproduced or duplicated, in any form, in whole or in part, without prior written consent of Renesas Electronics.
- Please contact a Renesas Electronics sales office if you have any questions regarding the information contained in this document or Renesas Electronics products, or if you have any other inquiries.  
(Note 1) "Renesas Electronics" as used in this document means Renesas Electronics Corporation and also includes its majority-owned subsidiaries.  
(Note 2) "Renesas Electronics product(s)" means any product developed or manufactured by or for Renesas Electronics.



### SALES OFFICES

Renesas Electronics Corporation

<http://www.renesas.com>

Refer to "<http://www.renesas.com/>" for the latest and detailed information.

**Renesas Electronics America Inc.**  
2880 Scott Boulevard Santa Clara, CA 95050-2554, U.S.A.  
Tel: +1-408-586-6000, Fax: +1-408-586-6130

**Renesas Electronics Canada Limited**  
1101 Nicholson Road, Newmarket, Ontario L3Y 9C3, Canada  
Tel: +1-905-898-5441, Fax: +1-905-898-3220

**Renesas Electronics Europe Limited**  
Dukes Meadow, Millboard Road, Bourne End, Buckinghamshire, SL8 5FH, U.K.  
Tel: +44-1628-585-100, Fax: +44-1628-585-900

**Renesas Electronics Europe GmbH**  
Arcadiastrasse 10, 40472 Düsseldorf, Germany  
Tel: +49-211-65030, Fax: +49-211-6503-1327

**Renesas Electronics (China) Co., Ltd.**  
7th Floor, Quantum Plaza, No.27 ZhiChunLu Haidian District, Beijing 100083, P.R.China  
Tel: +86-10-8235-1155, Fax: +86-10-8235-7679

**Renesas Electronics (Shanghai) Co., Ltd.**  
Unit 204, 205, AZIA Center, No.1233 Lujiazui Ring Rd., Pudong District, Shanghai 200120, China  
Tel: +86-21-5877-1818, Fax: +86-21-6887-7858 / -7898

**Renesas Electronics Hong Kong Limited**  
Unit 1601-1613, 16/F., Tower 2, Grand Century Place, 193 Prince Edward Road West, Mongkok, Kowloon, Hong Kong  
Tel: +852-2886-9318, Fax: +852 2886-9022/9044

**Renesas Electronics Taiwan Co., Ltd.**  
7F, No. 363 Fu Shing North Road Taipei, Taiwan  
Tel: +886-2-8175-9600, Fax: +886 2-8175-9670

**Renesas Electronics Singapore Pte. Ltd.**  
1 HarbourFront Avenue, #06-10, Keppel Bay Tower, Singapore 098632  
Tel: +65-6213-0200, Fax: +65-6276-8001

**Renesas Electronics Malaysia Sdn.Bhd.**  
Unit 906, Block B, Menara Amcorp, Amcorp Trade Centre, No. 18, Jin Persiaran Barat, 46050 Petaling Jaya, Selangor Darul Ehsan, Malaysia  
Tel: +60-3-7955-9390, Fax: +60-3-7955-9510

**Renesas Electronics Korea Co., Ltd.**  
11F., Samik Lavied' or Bldg., 720-2 Yeoksam-Dong, Kangnam-Ku, Seoul 135-080, Korea  
Tel: +82-2-558-3737, Fax: +82-2-558-5141