

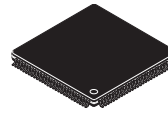

MCF52277

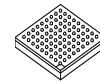

LQFP-176
24 mm x 24 mm



MAPBGA-196
15mm x 15mm

MCF5227x ColdFire® Microprocessor Data Sheet

Features

- Version 2 ColdFire® Core with EMAC
- Up to 159 Dhrystone 2.1 MIPS @ 166.67 MHz
- 8 Kbytes configurable cache (instruction only, data only, or split instruction/data)
- 128 Kbytes internal SRAM
- Support for booting from SPI-compatible flash, EEPROM, and FRAM devices
- Crossbar switch technology (XBS) for concurrent access to peripherals or RAM from multiple bus masters
- 16 channel DMA controller
- 16- or 32-bit SDR/DDR controller
- USB 2.0 On-the-Go controller
- Liquid crystal display controller with support up to 800 × 600 pixels
- ADC and touchscreen controller
- FlexCAN module
- 4 32-bit timers with DMA support
- DMA supported serial peripheral interface (DSPI)
- 3 UARTs
- I²C bus interface
- Synchronous serial interface (SSI)
- Pulse-width modulator (PWM)
- Real-time clock (RTC)
- Two programmable interrupt controllers (PIT)

Freescale reserves the right to change the detail specifications as may be required to permit improvements in the design of its products.

© Freescale Semiconductor, Inc., 2009. All rights reserved.

Table of Contents

1	MCF5227x Family Comparison	4	5.5	Oscillator and PLL Electrical Characteristics	19
2	Ordering Information	5	5.6	ASP Electrical Characteristics	20
3	Hardware Design Considerations	5	5.7	External Interface Timing Specifications	21
3.1	PLL Power Filtering	5	5.7.1	FlexBus	21
3.2	USB Power Filtering	5	5.7.2	SDRAM Bus	23
3.3	ADC Power Filtering	6	5.8	General Purpose I/O Timing	29
3.4	Supply Voltage Sequencing	6	5.9	Reset and Configuration Override Timing	29
3.4.1	Power Up Sequence	6	5.10	LCD Controller Timing Specifications	30
3.4.2	Power Down Sequence	6	5.11	USB On-The-Go Specifications	33
3.5	Power Consumption Specifications	7	5.12	SSI Timing Specifications	34
4	Pin Assignments and Reset States	9	5.13	I ² C Timing Specifications	36
4.1	Signal Multiplexing	9	5.14	DMA Timer Timing Specifications	38
4.2	Pinout—176 LQFP	14	5.15	DSPI Timing Specifications	38
4.3	Pinout—196 MAPBGA	15	5.16	SBF Timing Specifications	39
5	Electrical Characteristics	15	5.17	JTAG and Boundary Scan Timing Specifications	40
5.1	Maximum Ratings	16	5.18	Debug AC Timing Specifications	42
5.2	Thermal Characteristics	17	6	Package Information	43
5.3	ESD Protection	18	7	Product Documentation	43
5.4	DC Electrical Specifications	18	8	Revision History	44

MCF52277

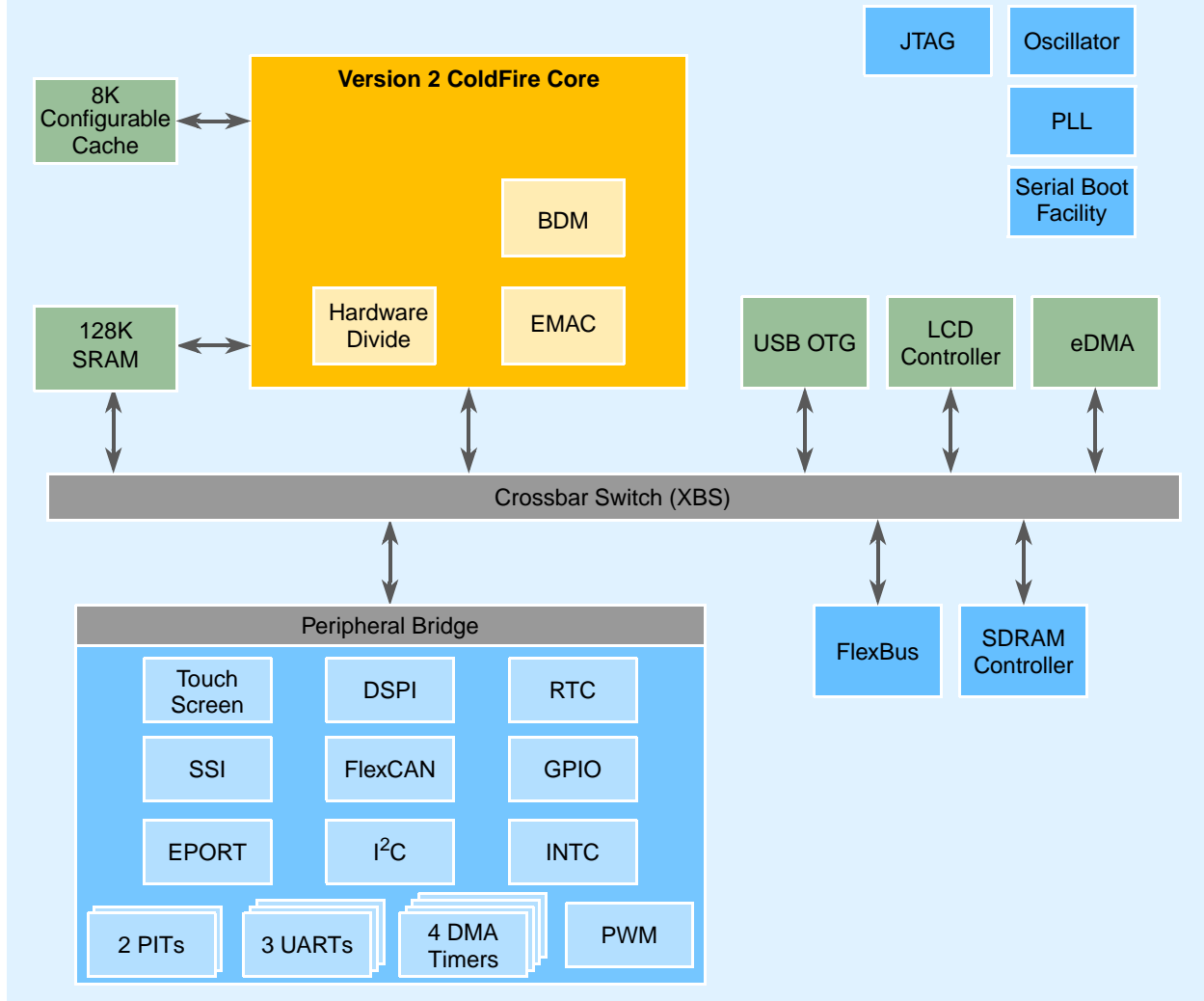

LEGEND

BDM	– Background debug module	LCD	– Liquid-crystal display
DSPI	– DMA serial peripheral interface	PIT	– Programmable interrupt timer
eDMA	– Enhanced direct memory access	PLL	– Phase-locked loop module
EMAC	– Enhanced multiply-accumulate unit	PWM	– Pulse-width modulator
EPORT	– Edge port module	RTC	– Real time clock
GPIO	– General purpose input/output module	SSI	– Synchronous serial interface
I²C	– Inter-integrated circuit	UART	– Universal asynchronous receiver/transmitter
INTC	– Interrupt controller	USB OTG	– Universal Serial Bus On-the-Go controller
JTAG	– Joint Test Action Group interface		

Figure 1. MCF52277 Block Diagram

1 MCF5227x Family Comparison

The following table compares the various device derivatives available within the MCF5227x family.

Table 1. MCF5227x Family Configurations

Module	MCF52274	MCF52277
ColdFire Version 2 Core with EMAC (Enhanced Multiply-Accumulate Unit)	•	•
Core (System) Clock	up to 120 MHz	up to 166.67 MHz
Peripheral and External Bus Clock (Core clock ÷ 2)	up to 60 MHz	up to 83.33 MHz
Performance (Dhrystone/2.1 MIPS)	up to 114	up to 159
Static RAM (SRAM)	128 Kbytes	
Configurable Cache	8 Kbytes	
ASP Touchscreen Controller	•	•
LCD Controller	12-bit color	18-bit color
USB 2.0 On-the-Go	•	•
FlexBus External Interface	•	•
SDR/DDR SDRAM Controller	•	•
FlexCAN 2.0B communication module	•	•
Real Time Clock	•	•
Watchdog Timer	•	•
16-channel Direct Memory Access (DMA)	•	•
Interrupt Controllers (INTC)	1	1
Synchronous Serial Interface (SSI)	•	•
I ² C	•	•
DSPI	•	•
UARTs	3	3
32-bit DMA Timers	4	4
Periodic Interrupt Timers (PIT)	2	2
PWM Module	•	•
Edge Port Module (EPORT)	•	•
General Purpose I/O Module (GPIO)	•	•
JTAG - IEEE [®] 1149.1 Test Access Port	•	•
Package	176 LQFP	196 MAPBGA

2 Ordering Information

Table 2. Orderable Part Numbers

Freescall Part Number	Description	Package	Speed	Temperature
MCF52274CLU120	MCF52274 RISC Microprocessor	176 LQFP	120 MHz	-40° to +85° C
MCF52277CVM160	MCF52277 RISC Microprocessor	196 MAPBGA	166.67 MHz	-40° to +85° C

3 Hardware Design Considerations

3.1 PLL Power Filtering

To further enhance noise isolation, an external filter is strongly recommended for PLL analog V_{DD} pins. The filter shown in Figure 2 should be connected between the board V_{DD} and the PLL V_{DD} pins. The resistor and capacitors should be placed as close to the dedicated PLL V_{DD} pin as possible.

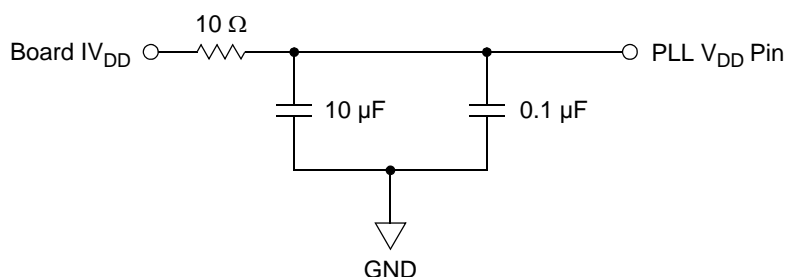
Figure 2. System PLL V_{DD} Power Filter

3.2 USB Power Filtering

To minimize noise, external filters are required for each of the USB power pins. The filter shown in Figure 3 should be connected between the board $E_{V_{DD}}$ and the USB V_{DD} pin. The resistor and capacitors should be placed as close to the dedicated USB V_{DD} pin as possible.

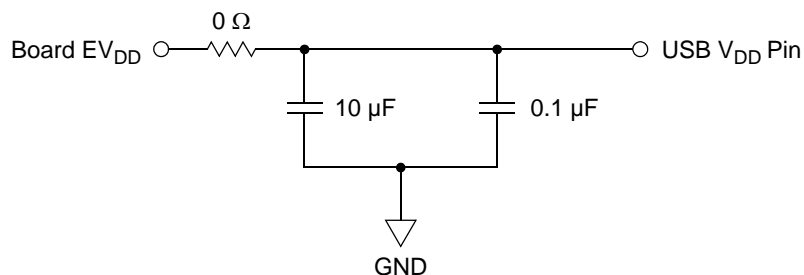
Figure 3. USB V_{DD} Power Filter

NOTE

In addition to the above filter circuitry, a 0.01 F capacitor is also recommended in parallel with those shown.

3.3 ADC Power Filtering

To minimize noise, an external filter is required for the ADCV_{DD} power pin. The filter shown in Figure 4 should be connected between the board EV_{DD} and the ADCV_{DD} pin. The resistor and capacitors should be placed as close to the dedicated ADCV_{DD} pin as possible.

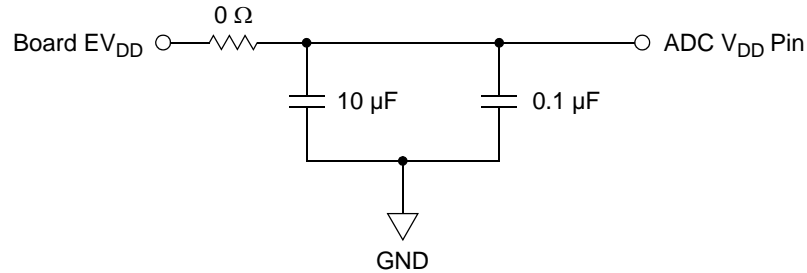

Figure 4. ADC V_{DD} Power Filter

3.4 Supply Voltage Sequencing

The relationship between SDV_{DD} and EV_{DD} is non-critical during power-up and power-down sequences. Both SDV_{DD} (2.5V or 3.3V) and EV_{DD} are specified relative to IV_{DD}.

3.4.1 Power Up Sequence

If EV_{DD}/SDV_{DD} are powered up with IV_{DD} at 0 V, then the sense circuits in the I/O pads will cause all pad output drivers connected to the EV_{DD}/SDV_{DD} to be in a high impedance state. There is no limit on how long after EV_{DD}/SDV_{DD} powers up before IV_{DD} must be powered up. IV_{DD} should not lead the EV_{DD}, SDV_{DD} or PLLV_{DD} by more than 0.4 V during power ramp-up, or there will be high current in the internal ESD protection diodes. The rise times on the power supplies should be slower than 500 us to avoid turning on the internal ESD protection clamp diodes.

3.4.2 Power Down Sequence

If IV_{DD}/PLLV_{DD} are powered down first, then sense circuits in the I/O pads will cause all output drivers to be in a high impedance state. There is no limit on how long after IV_{DD} and PLLV_{DD} power down before EV_{DD} or SDV_{DD} must power down. IV_{DD} should not lag EV_{DD}, SDV_{DD}, or PLLV_{DD} going low by more than 0.4 V during power down or there will be undesired high current in the ESD protection diodes. There are no requirements for the fall times of the power supplies.

The recommended power down sequence is as follows:

1. Drop IV_{DD}/PLLV_{DD} to 0 V.
2. Drop EV_{DD}/SDV_{DD} supplies.

3.5 Power Consumption Specifications

All application power consumption data is lab data measured on an M52277EVB running the Freescale Linux BSP.

Table 3. MCF52277 Application Power Consumption¹

Core Freq.		Idle (LCD image)	Idle (audio image)	Button Demo	Slideshow Demo	MP3 Playback	USB FS File Copy	Units
160 MHz	IV_{DD}	61.4	59.2	84.7	96.5	89.2	89.5	mA
	EV_{DD}	28.87	25.73	35.3	34.6	33.46	29.86	
	SDV_{DD}	18.8	18.57	21.8	23.9	22.66	22.2	
	Total Power	221.211	207.135	282.78	301.95	285.006	272.748	mW

¹ All voltage rails at nominal values: $IV_{DD} = 1.5$ V, $EV_{DD} = 3.3$ V, and $SDV_{DD} = 1.8$ V.

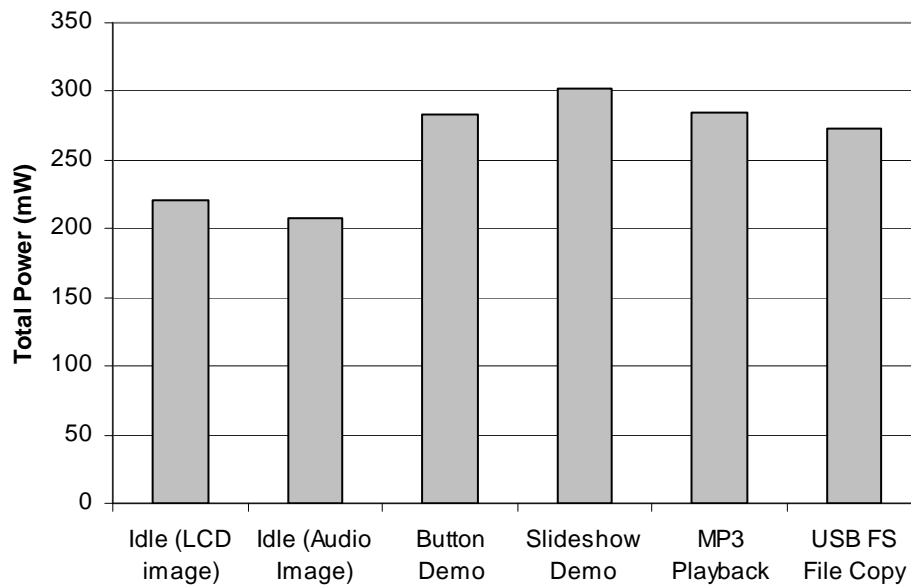

Figure 5. Power Consumption in Various Applications

All current consumption data is lab data measured on a single device using an evaluation board. Table 4 shows the typical power consumption in low-power modes. These current measurements are taken after executing a STOP instruction.

Table 4. Current Consumption in Low-Power Modes^{1,2}

Mode	Voltage Supply	System Frequency				
		80MHz	64MHz	48MHz	32MHz	4MHz (LIMP mode)
RUN	IV_{DD} (mA)	75.1	62.7	49.2	36.6	3.5
	Power (mW)	112.65	94.05	73.80	54.90	5.25
WAIT	IV_{DD} (mA)	61.9	52.8	42.0	31.7	2.9
	Power (mW)	92.85	79.20	63.00	47.55	4.35

Table 4. Current Consumption in Low-Power Modes^{1,2} (continued)

Mode	Voltage Supply	System Frequency				
		80MHz	64MHz	48MHz	32MHz	4MHz (LIMP mode)
DOZE	I_{DD} (mA)	57.0	48.8	38.9	29.7	2.7
	Power (mW)	85.50	73.20	58.35	44.55	4.05
STOP 0	I_{DD} (mA)	16.1	15.1	13.4	12.5	1.3
	Power (mW)	24.15	22.65	20.10	18.75	1.95
STOP 1	I_{DD} (mA)	15.9	14.9	13.2	12.4	1.3
	Power (mW)	23.85	22.35	19.80	18.60	1.95
STOP 2	I_{DD} (mA)	1.8	1.8	1.8	1.8	1.3
	Power (mW)	2.70	2.70	2.70	2.70	1.95
STOP 3	I_{DD} (mA)	0.5	0.5	0.5	0.5	0.5
	Power (mW)	0.75	0.75	0.75	0.75	0.75

¹ All values are measured on an M52277EVB with nominal core voltage ($I_{DD} = 1.5$ V). Tests performed at room temperature. All peripheral clocks on prior to entering low-power mode
² Refer to the Power Management chapter in the *MCF52277 Reference Manual* for more information on low-power modes.

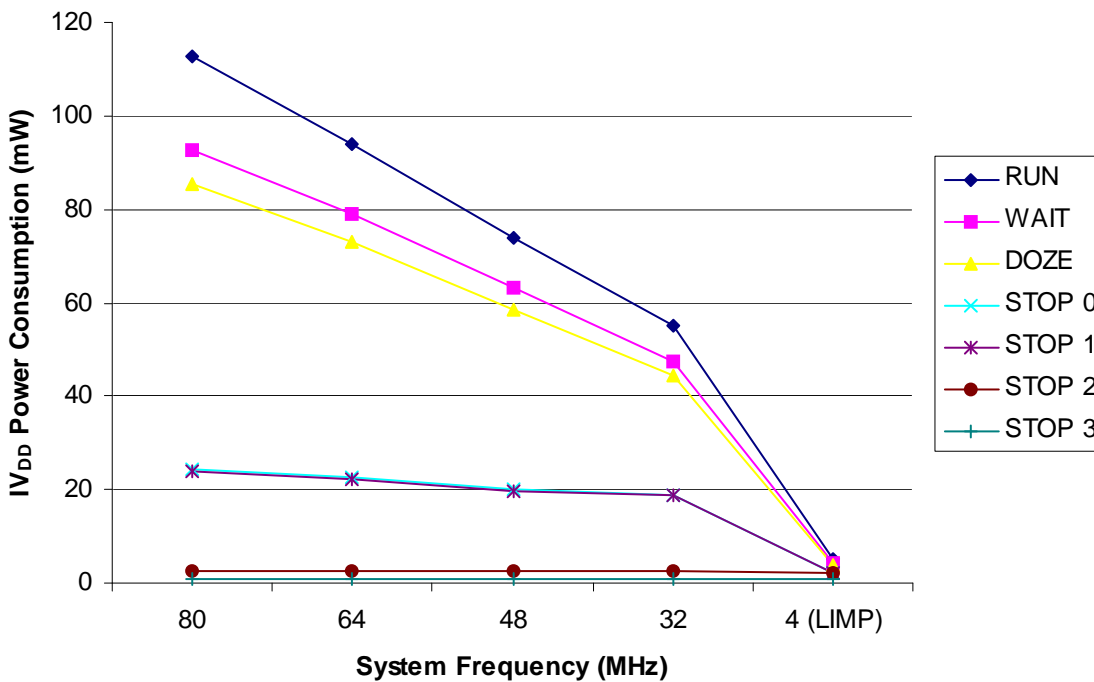

Figure 6. I_{DD} Power Consumption in Low-Power Modes

4 Pin Assignments and Reset States

4.1 Signal Multiplexing

The following table lists all the MCF5227x pins grouped by function. The direction column is the direction for the primary function of the pin only. Refer to [Section 4, “Pin Assignments and Reset States,”](#) for package diagrams. For a more detailed discussion of the MCF5227x signals, consult the *MCF52277 Reference Manual* (MCF52277RM).

NOTE

In this table and throughout this document a single signal within a group is designated without square brackets (i.e., FB_A23), while designations for multiple signals within a group use brackets (i.e., FB_A[23:21]) and is meant to include all signals within the two bracketed numbers when these numbers are separated by a colon.

NOTE

The primary functionality of a pin is not necessarily its default functionality. Most pins that are muxed with GPIO will default to their GPIO functionality. See [Table 5](#) for a list of the exceptions.

Table 5. Special-Case Default Signal Functionality

Pin	Default Signal
$\overline{\text{FB_BE/BWE}}[3:0]$	$\overline{\text{FB_BE/BWE}}[3:0]$
$\overline{\text{FB_CS}}[3:0]$	$\overline{\text{FB_CS}}[3:0]$
$\overline{\text{FB_OE}}$	$\overline{\text{FB_OE}}$
$\overline{\text{FB_TA}}$	$\overline{\text{FB_TA}}$
$\overline{\text{FB_R/W}}$	$\overline{\text{FB_R/W}}$
$\overline{\text{FB_TS}}$	$\overline{\text{FB_TS}}$

Table 6. MCF5227x Signal Information and Muxing

Signal Name	GPIO	Alternate 1	Alternate 2	Pull-up (U) ¹ Pull-down (D)	Direction ²	Voltage Domain	MCF52274 176 LQFP	MCF52277 196 MAPBGA
Reset								
$\overline{\text{RESET}}$	—	—	—	U	I	EVDD	103	J11
$\overline{\text{RSTOUT}}$	—	—	—	—	O	EVDD	102	K11
Clock								
EXTAL	—	—	—	—	I	EVDD	106	F14
XTAL	—	—	—	U ³	O	EVDD	105	G14
Mode Selection								
BOOTMOD[1:0]	—	—	—	—	I	EVDD	110, 109	G10, H10

Table 6. MCF5227x Signal Information and Muxing (continued)

Signal Name	GPIO	Alternate 1	Alternate 2	Pull-up (U) ¹ Pull-down (D)	Direction ²	Voltage Domain	MCF52274 176 LQFP	MCF52277 196 MAPBGA
FlexBus								
FB_A[23:22]	—	$\overline{\text{FB_CS}}[5:4]$	—	—	O	SDVDD	143, 142	C11, D11
FB_A[21:16]	—	—	—	—	O	SDVDD	141–139, 137–135	A12, B12, C12, B13, A13, A14
FB_A[15:14]	—	SD_BA[1:0]	—	—	O	SDVDD	131, 130	B14, C13
FB_A[13:11]	—	SD_A[13:11]	—	—	O	SDVDD	129–127	C14, D12, D13
FB_A10	—	—	—	—	O	SDVDD	126	D14
FB_A[9:0]	—	SD_A[9:0]	—	—	O	SDVDD	125–116	E11–E14, F11–F13, G11, G12, H11
FB_D[31:16]	—	SD_D[31:16]	—	—	I/O	SDVDD	30–37, 49–56	J4, K1–K4, L1–L3, M3, N3, P3, M4, N4, P4, L5, M5
FB_D[15:0]	—	FB_D[31:16]	—	—	I/O	SDVDD	19–26, 60–67	G1–G4, H1–H4, M6, N6, P6, L7, M7, N7, P7, L8
FB_CLK	—	—	—	—	O	SDVDD	42	P1
$\overline{\text{FB_BE/BWE}}[3:0]$	PBE[3:0]	SD_DQM[3:0]	—	—	O	SDVDD	29, 57, 27, 59	J3, N5, J1, L6
$\overline{\text{FB_CS}}[3:2]$	PCS[3:2]	—	—	—	O	SDVDD	—	B11, A11
$\overline{\text{FB_CS}}1$	PCS1	$\overline{\text{SD_CS}}1$	—	—	O	SDVDD	144	D10
$\overline{\text{FB_CS}}0$	PCS0	—	—	—	O	SDVDD	145	C10
$\overline{\text{FB_OE}}$	PFBCTL3	—	—	—	O	SDVDD	69	N8
$\overline{\text{FB_TA}}$	PFBCTL2	—	—	U	I	SDVDD	115	H12
$\overline{\text{FB_R}}\overline{\text{W}}$	PFBCTL1	—	—	—	O	SDVDD	68	M8
$\overline{\text{FB_TS}}$	PFBCTL0	$\overline{\text{DACK}}0$	—	—	O	SDVDD	15	F4
SDRAM Controller								
SD_A10	—	—	—	—	O	SDVDD	46	L4
$\overline{\text{SD_CAS}}$	—	—	—	—	O	SDVDD	47	N2
SD_CKE	—	—	—	—	O	SDVDD	17	F2
SD_CLK	—	—	—	—	O	SDVDD	40	M1
$\overline{\text{SD_CLK}}$	—	—	—	—	O	SDVDD	41	N1
$\overline{\text{SD_CS}}0$	—	—	—	—	O	SDVDD	18	F1
SD_DQS[3:2]	—	—	—	—	I/O	SDVDD	28, 58	J2, P5
$\overline{\text{SD_RAS}}$	—	—	—	—	O	SDVDD	48	P2

Table 6. MCF5227x Signal Information and Muxing (continued)

Signal Name	GPIO	Alternate 1	Alternate 2	Pull-up (U) ¹ Pull-down (D)	Direction ²	Voltage Domain	MCF52274 176 LQFP	MCF52277 196 MAPBGA
SD_SDR_DQS	—	—	—	—	O	SDVDD	38	M2
$\overline{\text{SD_WE}}$	—	—	—	—	O	SDVDD	16	F3
External Interrupts Port⁴								
$\overline{\text{IRQ7}}$	PIRQ7	—	—	—	I	EVDD	162	D7
$\overline{\text{IRQ4}}$	PIRQ4	$\overline{\text{DREQ0}}$	DSPI_PCS4	⁵	I	EVDD	161	C7
$\overline{\text{IRQ1}}$	PIRQ1	USB_CLKIN	SSI_CLKIN	—	I	EVDD	160	B7
LCD Controller⁶								
LCD_D[17:16] ⁶	PLCDDH[1:0]	LCD_D[11:10]	—	—	O	EVDD	9, 8	E3, E4
LCD_D[15:14] ⁶	PLCDDM[7:6]	LCD_D[9:8]	—	—	O	EVDD	7, 6	D1, D2
LCD_D13	PLCDDM5	CANTX	—	—	O	EVDD	—	C1
LCD_D12	PLCDDM4	CANRX	—	—	O	EVDD	—	C2
LCD_D[11:8] ⁶	PLCDDM[3:0]	LCD_D[7:4]	—	—	O	EVDD	5–2	D3, C3, D4, B1
LCD_D7	PLCDDL7	PWM7	—	—	O	EVDD	—	B2
LCD_D6	PLCDDL6	PWM5	—	—	O	EVDD	—	A1
LCD_D[5:2] ⁶	PLCDDL[5:2]	LCD_D[3:0]	—	—	O	EVDD	175–172	A2, A3, B3, A4
LCD_D1	PLCDDL1	PWM3	—	—	O	EVDD	—	B4
LCD_D0	PLCDDL0	PWM1	—	—	O	EVDD	—	C4
LCD_ACD/ LCD_OE	PLCDCTL3	LCD_SPL_SPR	—	—	O	EVDD	169	B5
LCD_FLM/ LCD_VSYNC	PLCDCTL2	—	—	—	O	EVDD	10	E2
LCD_LP/ LCD_HSYNC	PLCDCTL1	—	—	—	O	EVDD	11	E1
LCD_LSCLK	PLCDCTL0	—	—	—	O	EVDD	170	A5
USB On-the-Go								
USB_DM	—	—	—	—	O	USB VDD	149	A9
USB_DP	—	—	—	—	O	USB VDD	150	A10
Real Time Clock								
RTC_EXTAL	—	—	—	—	I	EVDD	100	J14
RTC_XTAL	—	—	—	—	O	EVDD	99	K14

Table 6. MCF5227x Signal Information and Muxing (continued)

Signal Name	GPIO	Alternate 1	Alternate 2	Pull-up (U) ¹ Pull-down (D)	Direction ²	Voltage Domain	MCF52274 176 LQFP	MCF52277 196 MAPBGA
Touchscreen Controller								
ADC_IN[7:0]	—	—	—	—	I	VDD_ ADC	82–85, 87–90	P12, N12, P13, N13, P14, N14, M13, M14
ADC_REF	—	—	—	—	I	VDD_ ADC	86	M12
I²C								
I2C_SCL	PI2C1	CANTX	U2TXD	U	I/O	EVDD	168	C5
I2C_SDA	PI2C0	CANRX	U2RXD	U	I/O	EVDD	167	D5
DSPI⁷								
DSPI_PCS0/ \overline{SS}	PDSP13	$\overline{U2RTS}$	—	U	I/O	EVDD	152	B9
DSPI_SIN	PDSP12	U2RXD	SBF_DI	⁸	I	EVDD	155	D8
DSPI_SOUT	PDSP11	U2TXD	SBF_D0	—	O	EVDD	154	D9
DSPI_SCK	PDSP10	$\overline{U2CTS}$	SBF_CK	—	I/O	EVDD	153	C9
UARTs								
$\overline{U1CTS}$	PUART7	SSI_BCLK	LCD_CLS	—	I	EVDD	156	C8
$\overline{U1RTS}$	PUART6	SSI_FS	LCD_PS	—	O	EVDD	157	B8
U1TXD	PUART5	SSI_TXD	—	—	O	EVDD	159	A7
U1RXD	PUART4	SSI_RXD	—	—	I	EVDD	158	A8
$\overline{U0CTS}$	PUART3	DT1OUT	USB_VBUS_EN	—	I	EVDD	97	K12
$\overline{U0RTS}$	PUART2	DT1IN	USB_VBUS_OC	—	O	EVDD	98	J12
U0TXD	PUART1	CANTX	—	—	O	EVDD	95	L12
U0RXD	PUART0	CANRX	—	—	I	EVDD	96	K13
DMA Timers								
DT3IN	PTIMER3	DT3OUT	SSI_MCLK	—	I	EVDD	163	D6
DT2IN/ $\overline{SBF_CS}$ ⁷	PTIMER2	DT2OUT	DSPI_PCS2	—	I	EVDD	164	C6
DT1IN	PTIMER1	DT1OUT	LCD_CONTRAST	—	I	EVDD	165	B6
DT0IN	PTIMER0	DT0OUT	LCD_REV	—	I	EVDD	166	A6
BDM/JTAG⁹								
PST[3:0]	—	—	—	—	O	EVDD	—	L9, M9, N9, P9
DDATA[3:0]	—	—	—	—	O	EVDD	—	L10, M10, N10, P10

Table 6. MCF5227x Signal Information and Muxing (continued)

Signal Name	GPIO	Alternate 1	Alternate 2	Pull-up (U) ¹ Pull-down (D)	Direction ²	Voltage Domain	MCF52274 176 LQFP	MCF52277 196 MAPBGA
ALLPST	—	—	—	—	O	EVDD	76	—
JTAG_EN	—	—	—	D	I	EVDD	79	K10
PSTCLK	—	TCLK	—	U	O	EVDD	74	P8
DSI	—	TDI	—	U	I	EVDD	78	M11
DSO	—	TDO	—	—	O	EVDD	81	L11
BKPT ³	—	TMS	—	U	I	EVDD	80	N11
DSCLK	—	TRST	—	U	I	EVDD	77	P11
Test								
TEST	—	—	—	D	I	EVDD	134	E10
Power Supplies								
IVDD	—	—	—	—	—	—	39, 75, 114, 138, 171	K5, F10, E5, J10
EVDD	—	—	—	—	—	—	12, 72, 73, 94, 111, 148, 176	E6, E7, F5, F6, G5, H9, J9, K8, K9
SD_VDD	—	—	—	—	—	—	14, 43, 44, 70, 113, 132, 146	E8, E9, F9, G9, H5, J5, J6, K6, K7
VDD_OSC	—	—	—	—	—	—	108	G13
VDD_PLL	—	—	—	—	—	—	104	H14
VDD_USB	—	—	—	—	—	—	151	B10
VDD_RTC	—	—	—	—	—	—	101	J13
VDD_ADC	—	—	—	—	—	—	91	L13
VSS	—	—	—	—	—	—	1, 13, 45, 71, 93, 112, 133, 147	F7, F8, G6–G8, H6–H8, J7, J8
VSS_OSC	—	—	—	—	—	—	107	H13
VSS_ADC	—	—	—	—	—	—	92	L14

¹ Pull-ups are generally only enabled on pins with their primary function, except as noted.

² Refers to pin's primary function.

³ Enabled only in oscillator bypass mode (internal crystal oscillator is disabled).

⁴ GPIO functionality is determined by the edge port module. The GPIO module is only responsible for assigning the alternate functions.

⁵ Pull-up when \overline{DREQ} controls the pin.

⁶ The 176 LQFP device only supports a 12-bit LCD data bus.

⁷ DSPI or SBF signal functionality is controlled by \overline{RESET} . When asserted, these pins are configured for serial boot; when negated, the pins are configured for DSPI.

⁸ Pull-up when the serial boot facility (SBF) controls the pin.

Pin Assignments and Reset States

- 9 If JTAG_EN is asserted, these pins default to alternate 1 (JTAG) functionality. The GPIO module is not responsible for assigning these pins.

4.2 Pinout—176 LQFP

The pinout for the MCF52274 package is shown below.

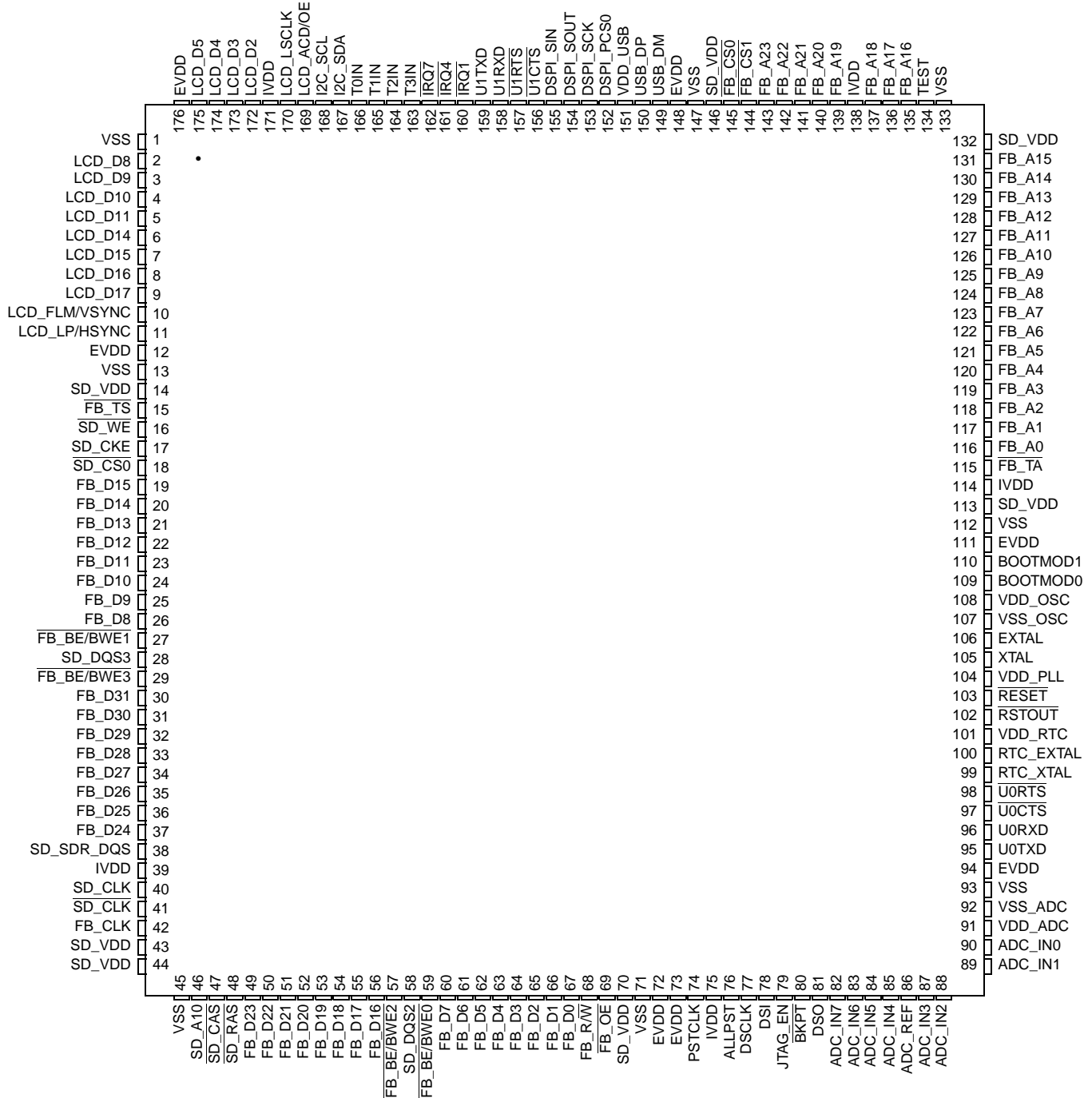

Figure 7. MCF52274 Pinout (176 LQFP)

4.3 Pinout—196 MAPBGA

The pinout for the MCF52277 package is shown below.

	1	2	3	4	5	6	7	8	9	10	11	12	13	14	
A	LCD_D6	LCD_D5	LCD_D4	LCD_D2	LCD_LSCLK	T0IN	U1TXD	U1RXD	USB_DM	USB_DP	$\overline{\text{FB_CS2}}$	FB_A21	FB_A17	FB_A16	A
B	LCD_D8	LCD_D7	LCD_D3	LCD_D1	LCD_ACD/OE	T1IN	$\overline{\text{IRQ}}_1$	$\overline{\text{U1RTS}}$	DSPI_PCS0	VDD_USB	$\overline{\text{FB_CS3}}$	FB_A20	FB_A18	FB_A15	B
C	LCD_D13	LCD_D12	LCD_D10	LCD_D0	I2C_SCL	T2IN	$\overline{\text{IRQ}}_4$	$\overline{\text{U1CTS}}$	DSPI_SCK	$\overline{\text{FB_CS0}}$	FB_A23	FB_A19	FB_A14	FB_A13	C
D	LCD_D15	LCD_D14	LCD_D11	LCD_D9	I2C_SDA	T3IN	$\overline{\text{IRQ}}_7$	DSPI_SIN	DSPI_SOUT	$\overline{\text{FB_CS1}}$	FB_A22	FB_A12	FB_A11	FB_A10	D
E	LCD_LP/HSYNC	LCD_FLM/VSYNC	LCD_D17	LCD_D16	IVDD	EVDD	EVDD	SDVDD	SDVDD	TEST	FB_A9	FB_A8	FB_A7	FB_A6	E
F	$\overline{\text{SD_CS0}}$	SD_CKE	$\overline{\text{SD_WE}}$	$\overline{\text{FB_TS}}$	EVDD	EVDD	VSS	VSS	SDVDD	IVDD	FB_A5	FB_A4	FB_A3	EXTAL	F
G	FB_D15	FB_D14	FB_D13	FB_D12	EVDD	VSS	VSS	VSS	SDVDD	BOOT_MOD1	FB_A2	FB_A1	VDD_OSC	XTAL	G
H	FB_D11	FB_D10	FB_D9	FB_D8	SDVDD	VSS	VSS	VSS	EVDD	BOOT_MOD0	FB_A0	$\overline{\text{FB_TA}}$	VSS_OSC	VDD_PLL	H
J	$\overline{\text{FB_BE/BWE1}}$	SD_DQS3	$\overline{\text{FB_BE/BWE3}}$	FB_D31	SDVDD	SDVDD	VSS	VSS	EVDD	IVDD	RESET	$\overline{\text{U0RTS}}$	VDD_RTC	RTC_EXTAL	J
K	FB_D30	FB_D29	FB_D28	FB_D27	IVDD	SDVDD	SDVDD	EVDD	EVDD	JTAG_EN	RSTOUT	$\overline{\text{U0CTS}}$	U0RXD	RTC_XTAL	K
L	FB_D26	FB_D25	FB_D24	SD_A10	FB_D17	$\overline{\text{FB_BE/BWE0}}$	FB_D4	FB_D0	PST3	DDATA3	TDO	U0TXD	VDD_ADC	VSS_ADC	L
M	SD_CLK	SD_SDR_DQS	FB_D23	FB_D20	FB_D16	FB_D7	FB_D3	FB_R $\overline{\text{W}}$	PST2	DDATA2	TDI	ADC_REF	ADC_IN1	ADC_IN0	M
N	$\overline{\text{SD_CLK}}$	$\overline{\text{SD_CAS}}$	FB_D22	FB_D19	$\overline{\text{FB_BE/BWE2}}$	FB_D6	FB_D2	$\overline{\text{FB_OE}}$	PST1	DDATA1	TMS	ADC_IN6	ADC_IN4	ADC_IN2	N
P	FB_CLK	$\overline{\text{SD_RAS}}$	FB_D21	FB_D18	SD_DQS0	FB_D5	FB_D1	TCLK	PST0	DDATA0	$\overline{\text{TRST}}$	ADC_IN7	ADC_IN5	ADC_IN3	P

Figure 8. MCF52277 Pinout (196 MAPBGA)

5 Electrical Characteristics

This document contains electrical specification tables and reference timing diagrams for the MCF5227x microprocessor. This section contains detailed information on DC/AC electrical characteristics and AC timing specifications.

The electrical specifications are preliminary and are from previous designs or design simulations. These specifications may not be fully tested or guaranteed at this early stage of the product life cycle, however for production silicon these specifications will be met. Finalized specifications will be published after complete characterization and device qualifications have been completed.

NOTE

The parameters specified in this MCU document supersede any values found in the module specifications.

5.1 Maximum Ratings

Table 7. Absolute Maximum Ratings^{1, 2}

Characteristic	Symbol	Value	Unit
Core Supply Voltage	IV_{DD}	-0.5 to +2.0	V
CMOS Pad Supply Voltage	EV_{DD}	-0.3 to +4.0	V
DDR/Memory Pad Supply Voltage	SDV_{DD}	-0.3 to +4.0	V
Oscillator Supply Voltage	$OSCV_{DD}$	-0.3 to +4.0	V
PLL Supply Voltage	PLL_{VDD}	-0.3 to +2.0	V
RTC Supply Voltage	$RTCV_{DD}$	-0.5 to +2.0	V
Digital Input Voltage ³	V_{IN}	-0.3 to +3.6	V
Instantaneous Maximum Current Single pin limit (applies to all pins) ^{3, 4, 5}	I_D	25	mA
Operating Temperature Range (Packaged)	T_A ($T_L - T_H$)	-40 to +85	°C
Storage Temperature Range	T_{stg}	-55 to +150	°C

¹ Functional operating conditions are given in [Section 5.4, "DC Electrical Specifications."](#) Absolute maximum ratings are stress ratings only, and functional operation at the maxima is not guaranteed. Continued operation at these levels may affect device reliability or cause permanent damage to the device.

² This device contains circuitry protecting against damage due to high static voltage or electrical fields; however, it is advised that normal precautions be taken to avoid application of any voltages higher than maximum-rated voltages to this high-impedance circuit. Reliability of operation is enhanced if unused inputs are tied to an appropriate logic voltage level (e.g., either V_{SS} or EV_{DD}).

³ Input must be current limited to the value specified. To determine the value of the required current-limiting resistor, calculate resistance values for positive and negative clamp voltages, then use the larger of the two values.

⁴ All functional non-supply pins are internally clamped to V_{SS} and EV_{DD} .

⁵ Power supply must maintain regulation within operating EV_{DD} range during instantaneous and operating maximum current conditions. If positive injection current ($V_{in} > EV_{DD}$) is greater than I_{DD} , the injection current may flow out of EV_{DD} and could result in external power supply going out of regulation. Insure external EV_{DD} load will shunt current greater than maximum injection current. This will be the greatest risk when the MCU is not consuming power (ex; no clock). Power supply must maintain regulation within operating EV_{DD} range during instantaneous and operating maximum current conditions.

5.2 Thermal Characteristics

Table 8. Thermal Characteristics

Characteristic		Symbol	196 MAPBGA	176 LQFP	Unit
Junction to ambient, natural convection	Four layer board (2s2p)	θ_{JA}	38 ^{1,2}	48 ^{1,2}	°C/W
Junction to ambient (@200 ft/min)	Four layer board (2s2p)	θ_{JMA}	34 ^{1,2}	42 ^{1,2}	°C/W
Junction to board		θ_{JB}	27 ³	37 ³	°C/W
Junction to case		θ_{JC}	17 ⁴	14 ⁴	°C/W
Junction to top of package		Ψ_{jt}	4 ^{1,5}	3 ^{1,5}	°C/W
Maximum operating junction temperature		T_j	105	105	°C

¹ θ_{JA} , θ_{JMA} and Ψ_{jt} parameters are simulated in conformance with EIA/JESD Standard 51-2 for natural convection. Freescale recommends the use of θ_{JMA} and power dissipation specifications in the system design to prevent device junction temperatures from exceeding the rated specification. System designers should be aware that device junction temperatures can be significantly influenced by board layout and surrounding devices. Conformance to the device junction temperature specification can be verified by physical measurement in the customer's system using the Ψ_{jt} parameter, the device power dissipation, and the method described in EIA/JESD Standard 51-2.

² Per JEDEC JESD51-6 with the board horizontal.

³ Thermal resistance between the die and the printed circuit board in conformance with JEDEC JESD51-8. Board temperature is measured on the top surface of the board near the package.

⁴ Thermal resistance between the die and the case top surface as measured by the cold plate method (MIL SPEC-883 Method 1012.1).

⁵ Thermal characterization parameter indicating the temperature difference between package top and the junction temperature per JEDEC JESD51-2. When Greek letters are not available, the thermal characterization parameter is written in conformance with Psi-JT.

The average chip-junction temperature (T_j) in °C can be obtained from:

$$T_j = T_A + (P_D \times \theta_{JMA}) \quad \text{Eqn. 1}$$

Where:

T_A	= Ambient Temperature, °C
θ_{JMA}	= Package Thermal Resistance, Junction-to-Ambient, °C/W
P_D	= $P_{INT} + P_{I/O}$
P_{INT}	= $I_{DD} \times IV_{DD}$, Watts - Chip Internal Power
$P_{I/O}$	= Power Dissipation on Input and Output Pins - User Determined

For most applications $P_{I/O} < P_{INT}$ and can be ignored. An approximate relationship between P_D and T_j (if $P_{I/O}$ is neglected) is:

$$P_D = \frac{K}{(T_j + 273^\circ\text{C})} \quad \text{Eqn. 2}$$

Solving equations 1 and 2 for K gives:

$$K = P_D \times (T_A \times 273^\circ\text{C}) + \theta_{JMA} \times P_D^2 \quad \text{Eqn. 3}$$

where K is a constant pertaining to the particular part. K can be determined from Equation 3 by measuring P_D (at equilibrium) for a known T_A . Using this value of K, the values of P_D and T_j can be obtained by solving Equation 1 and Equation 2 iteratively for any value of T_A .

5.3 ESD Protection

Table 9. ESD Protection Characteristics^{1,2}

Characteristic	Symbol	Value	Unit
ESD Target for Human Body Model	HBM	2000	V

¹ All ESD testing is in conformity with CDF-AEC-Q100 Stress Test Qualification for Automotive Grade Integrated Circuits.

² A device is defined as a failure if after exposure to ESD pulses the device no longer meets the device specification requirements. Complete DC parametric and functional testing is performed per applicable device specification at room temperature followed by hot temperature, unless specified otherwise in the device specification.

5.4 DC Electrical Specifications

Table 10. DC Electrical Specifications

Characteristic	Symbol	Min	Max	Unit
Core Supply Voltage	IV_{DD}	1.4	1.6	V
PLL Supply Voltage	$PLL_{V_{DD}}$	1.4	1.6	V
RTC Supply Voltage	$RTC_{V_{DD}}$	1.4	1.6	V
CMOS Pad Supply Voltage	EV_{DD}	3.0	3.6	V
SDRAM and FlexBus Supply Voltage Mobile DDR/Bus Pad Supply Voltage (nominal 1.8V) DDR/Bus Pad Supply Voltage (nominal 2.5V) SDR/Bus Pad Supply Voltage (nominal 3.3V)	SDV_{DD}	1.7 2.25 3.0	1.95 2.75 3.6	V
USB Supply Voltage	$USB_{V_{DD}}$	3.0	3.6	V
Oscillator Supply Voltage	$OSC_{V_{DD}}$	3.0	3.6	V
CMOS Input High Voltage	EV_{IH}	2	$EV_{DD} + 0.3$	V
CMOS Input Low Voltage	EV_{IL}	$V_{SS} - 0.3$	0.8	V
CMOS Output High Voltage $I_{OH} = -5.0$ mA	EV_{OH}	$EV_{DD} - 0.4$	—	V
CMOS Output Low Voltage $I_{OL} = 5.0$ mA	EV_{OL}	—	0.4	V
SDRAM and FlexBus Input High Voltage Mobile DDR/Bus Input High Voltage (nominal 1.8V) DDR/Bus Pad Supply Voltage (nominal 2.5V) SDR/Bus Pad Supply Voltage (nominal 3.3V)	SDV_{IH}	1.35 1.7 2	$SDV_{DD} + 0.3$ $SDV_{DD} + 0.3$ $SDV_{DD} + 0.3$	V
SDRAM and FlexBus Input Low Voltage Mobile DDR/Bus Input High Voltage (nominal 1.8V) DDR/Bus Pad Supply Voltage (nominal 2.5V) SDR/Bus Pad Supply Voltage (nominal 3.3V)	SDV_{IL}	$V_{SS} - 0.3$ $V_{SS} - 0.3$ $V_{SS} - 0.3$	0.45 0.8 0.8	V

Table 10. DC Electrical Specifications (continued)

Characteristic	Symbol	Min	Max	Unit
SDRAM and FlexBus Output High Voltage Mobile DDR/Bus Input High Voltage (nominal 1.8V) DDR/Bus Pad Supply Voltage (nominal 2.5V) SDR/Bus Pad Supply Voltage (nominal 3.3V) $I_{OH} = -5.0$ mA for all modes	SDV_{OH}	1.4 2.1 2.4	— — —	V
SDRAM and FlexBus Output Low Voltage Mobile DDR/Bus Input High Voltage (nominal 1.8V) DDR/Bus Pad Supply Voltage (nominal 2.5V) SDR/Bus Pad Supply Voltage (nominal 3.3V) $I_{OL} = 5.0$ mA for all modes	SDV_{OL}	— — —	0.3 0.3 0.5	V
Input Leakage Current $V_{in} = V_{DD}$ or V_{SS} , Input-only pins	I_{in}	-1.0	1.0	μ A
Weak Internal Pull-Up Device Current, tested at V_{IL} Max. ¹	I_{APU}	-10	-130	μ A
Input Capacitance ² All input-only pins All input/output (three-state) pins	C_{in}	— —	7 7	pF

¹ Refer to the signals section for pins having weak internal pull-up devices.

² This parameter is characterized before qualification rather than 100% tested.

5.5 Oscillator and PLL Electrical Characteristics

Table 11. PLL Electrical Characteristics

Num	Characteristic	Symbol	Min	Max	Unit
1	PLL Reference Frequency Range Crystal reference External reference	$f_{ref_crystal}$	16	25 ¹	MHz
		f_{ref_ext}	16	66.67 ¹	MHz
2	Core/system frequency CLKOUT Frequency	f_{sys}	512 Hz ²	166.67	MHz
		$f_{sys/2}$	256 Hz ²	83.33	MHz
3	Crystal Start-up Time ^{3,4}	t_{cst}	—	10	ms
4	EXTAL Input High Voltage Crystal Mode ⁵ All other modes (External, Limp)	V_{IHEXT}	$V_{XTAL} + 0.4$	—	V
		V_{IHEXT}	$E_{VDD}/2 + 0.4$	—	V
5	EXTAL Input Low Voltage Crystal Mode ⁵ All other modes (External, Limp)	V_{ILEXT}	—	$V_{XTAL} - 0.4$	V
		V_{ILEXT}	—	$E_{VDD}/2 - 0.4$	V
7	PLL Lock Time ^{3,6}	t_{pll}	—	50000	CLKIN
8	Duty cycle of reference ³	t_{dc}	40	60	%
9	XTAL Current	I_{XTAL}	1	3	mA
10	Total on-chip stray capacitance on XTAL	C_{S_XTAL}	—	1.5	pF
11	Total on-chip stray capacitance on EXTAL	C_{S_EXTAL}	—	1.5	pF
12	Crystal capacitive load	C_L	See crystal spec		

Table 11. PLL Electrical Characteristics (continued)

Num	Characteristic	Symbol	Min	Max	Unit
13	Discrete load capacitance for XTAL Discrete load capacitance for EXTAL	C_{L_XTAL} C_{L_EXTAL}	—	$2 \times (C_L - C_{S_XTAL} - C_{S_EXTAL} - C_{S_PCB})^7$	pF
14	Frequency un-LOCK Range	f_{UL}	-4.0	4.0	% f_{sys}
15	Frequency LOCK Range	f_{LCK}	-2.0	2.0	% f_{sys}
17	CLKOUT period jitter ^{4, 5, 8} measured at f_{sys} max Peak-to-peak jitter (Clock edge to clock edge) Long-term jitter	C_{jitter}	— —	10 TBD	% $f_{sys}/2$ % $f_{sys}/2$
19	VCO frequency ($f_{vco} = f_{ref} \times PFDR$)	f_{vco}	350	540	MHz

¹ Although these are the allowable frequency ranges, do not violate the VCO frequency range of the PLL. See the *MCF5227x Reference Manual* for more details.

² The minimum system frequency is the minimum input clock divided by the maximum low-power divider (16 MHz ÷ 32,768). When the PLL is enabled, the minimum system frequency (f_{sys}) is 37.5 MHz.

³ This parameter is guaranteed by characterization before qualification rather than 100% tested. Applies to external clock reference only.

⁴ Proper PC board layout procedures must be followed to achieve specifications.

⁵ This parameter is guaranteed by design rather than 100% tested.

⁶ This specification is the PLL lock time only and does not include oscillator start-up time..

⁷ C_{S_PCB} is the measured PCB stray capacitance on EXTAL and XTAL.

⁸ Jitter is the average deviation from the programmed frequency measured over the specified interval at maximum f_{sys} . Measurements are made with the device powered by filtered supplies and clocked by a stable external clock signal. Noise injected into the PLL circuitry via PLL V_{DD} , EV_{DD} , and V_{SS} and variation in crystal oscillator frequency increase the C_{jitter} percentage for a given interval.

5.6 ASP Electrical Characteristics

Table 12 lists the electrical specifications for the ASP module.

Table 12. ASP Electrical Characteristics

Characteristic	Symbol	Min	Typical	Max	Unit
ASP Analog Supply Voltage	V_{DDA}	3.0	—	3.6	V
Input Voltage Range	V_{ADIN}	0	—	V_{DDA}	V
Operating Current Consumption	I_{DDA_ON}	—	700	—	uA
Power-down Current Consumption	I_{DDA_OFF}	—	1	—	uA
Resolution	R_{ES}	—	—	12	bits
Sampling rate		—	—	125	kS/s
Integral Non-linearity	INL	—	±8	±24	lsb ¹
Differential Non-linearity	DNL	—	±2	±24	lsb ¹
ADC Internal Clock Frequency	t_{AIC}	2	—	8	MHz
Conversion Range	R_{AD}	0	—	V_{DDA}	V

Table 12. ASP Electrical Characteristics (continued)

Characteristic	Symbol	Min	Typical	Max	Unit
Conversion Time	t_{ADC}	15	—	32	t_{AIC} cycles
Sample Time	t_{ADS}	3	—	20	t_{AIC} cycles
Multiplexer Settling Time	t_{AMS}	—	—	3	t_{AIC} cycles
Zero-scale Error	ZE	—	± 4	± 12	lsb ¹
Full-scale Error	FE	—	± 320	± 370	lsb ¹
Input Capacitance	C_{AIN}	—	—	34	pF

¹ A least significant bit (lsb) is a unit of voltage equal to the smallest resolution of the ADC. This unit of measure approximately relates the error voltage to the observed error in conversion (code error), and is useful for systemic errors such as differential non-linearity. A 2.56-V input on an ADC with ± 3 lsb of error could read between 0x1FD and 0x203. This unit is by far the most common terminology and will be the preferred unit used for error representation.

A bit is a unit equal to the log (base2) of the error voltage normalized to the resolution of the ADC. An error of N bits corresponds to 2^N lsb of error. This measure is easily confused with lsb and is hard to extrapolate between integer values.

5.7 External Interface Timing Specifications

5.7.1 FlexBus

A multi-function external bus interface called FlexBus is provided with basic functionality to interface to slave-only devices up to a maximum bus frequency of 66MHz. It can be directly connected to asynchronous or synchronous devices such as external boot ROMs, flash memories, gate-array logic, or other simple target (slave) devices with little or no additional circuitry. For asynchronous devices a simple chip-select based interface can be used.

All processor bus timings are synchronous; that is, input setup/hold and output delay are given in respect to the rising edge of a reference clock, FB_CLK. The FB_CLK frequency may be the same as the internal system bus frequency or an integer divider of that frequency.

The following timing numbers indicate when data will be latched or driven onto the external bus, relative to the Flexbus output clock, FB_CLK. All other timing relationships can be derived from these values.

Table 13. FlexBus AC Timing Specifications

Num	Characteristic	Symbol	Min	Max	Unit	Notes
	Frequency of Operation		—	83.33	MHz	$f_{sys}/2$
FB1	Clock Period (FB_CLK)	t_{FBCK}	12.0	—	ns	t_{cyc}
FB2	Address, Data, and Control Output Valid (FB_A[23:0], FB_D[31:0], FB_CS[5:0], FB_R/W, FB_TS, FB_BE/BWE[3:0] and FB_OE)	$t_{FBCHDCV}$	—	7.0	ns	¹
FB3	Address, Data, and Control Output Hold (FB_A[23:0], FB_D[31:0], FB_CS[5:0], FB_R/W, FB_TS, FB_BE/BWE[3:0], and FB_OE)	$t_{FBCHDCI}$	1	—	ns	^{1, 2}

Table 13. FlexBus AC Timing Specifications (continued)

Num	Characteristic	Symbol	Min	Max	Unit	Notes
FB4	Data Input Setup	t_{DVFBCH}	3.5	—	ns	
FB5	Data Input Hold	t_{DIFBCH}	0	—	ns	
FB6	Transfer Acknowledge (\overline{TA}) Input Setup	t_{CVFBCH}	4	—	ns	
FB7	Transfer Acknowledge (\overline{TA}) Input Hold	t_{CIFBCH}	0	—	ns	

¹ Timing for chip selects only applies to the $\overline{FB_CS}[5:0]$ signals. Please see [Section 5.7.2.2, “DDR SDRAM AC Timing Specifications,”](#) for $\overline{SD_CS}[3:0]$ timing.

² The FlexBus supports programming an extension of the address hold. Please consult the device reference manual for more information.

NOTE

The processor drives the data lines during the first clock cycle of the transfer with the full 32-bit address. This may be ignored by standard connected devices using non-multiplexed address and data buses. However, some applications may find this feature beneficial.

The address and data busses are muxed between the FlexBus and SDRAM controller. At the end of the read and write bus cycles the address signals are indeterminate.

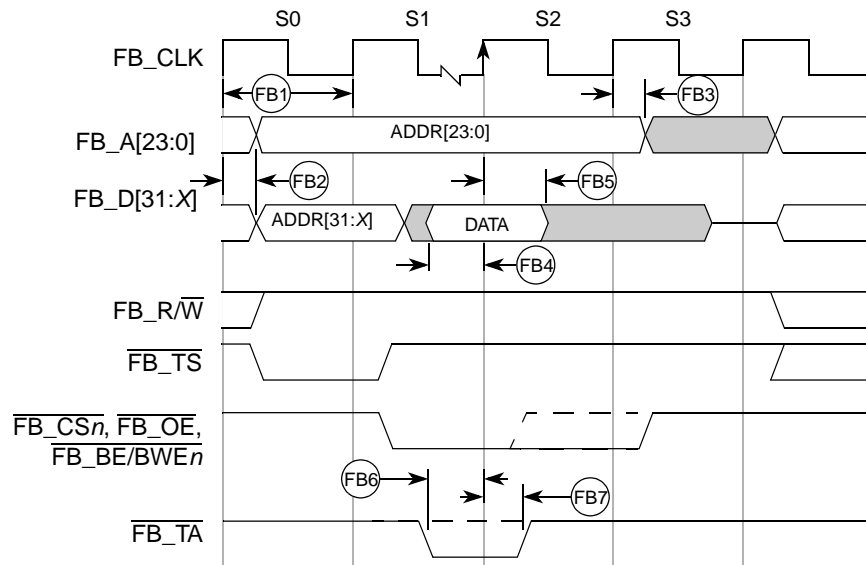

Figure 9. FlexBus Read Timing

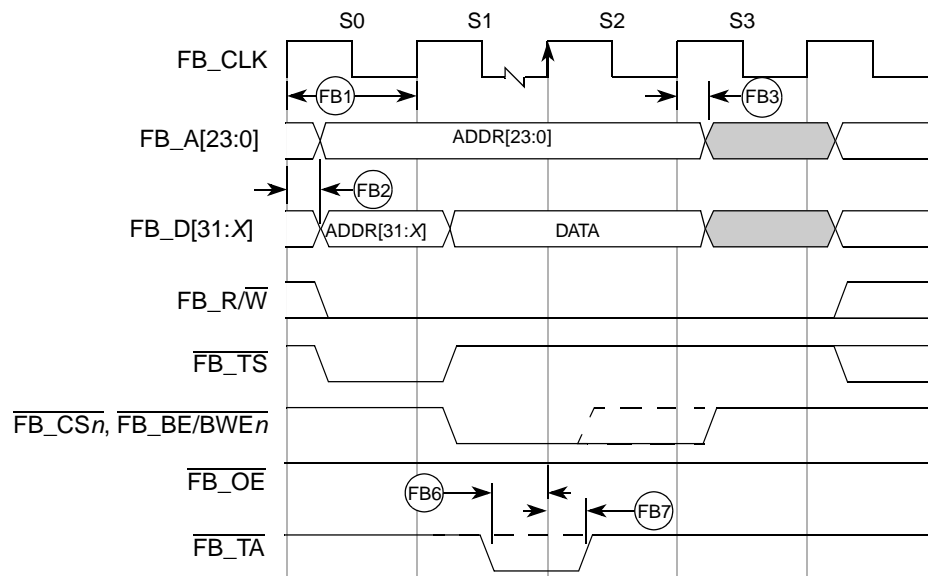

Figure 10. Flexbus Write Timing

5.7.2 SDRAM Bus

The SDRAM controller supports accesses to main SDRAM memory from any internal master. It supports either standard SDRAM or double data rate (DDR) SDRAM, but it does not support both at the same time.

5.7.2.1 SDR SDRAM AC Timing Specifications

The following timing numbers indicate when data will be latched or driven onto the external bus, relative to the memory bus clock, when operating in SDR mode on write cycles and relative to SD_DQS on read cycles. The device's SDRAM controller is a DDR controller that has an SDR mode. Because it is designed to support DDR, a DQS pulse must still be supplied to the device for each data beat of an SDR read. The processor accomplishes this by asserting a signal named SD_SDR_DQS during read cycles. Care must be taken during board design to adhere to the following guidelines and specs with regard to the SD_SDR_DQS signal and its usage.

Table 14. SDR Timing Specifications

Num	Characteristic	Symbol	Min	Max	Unit	Notes
	Frequency of Operation		60	83.33	MHz	¹
SD1	Clock Period	t_{SDCK}	12.0	16.67	ns	²
SD2	Pulse Width High	t_{SDCKH}	0.45	0.55	SD_CLK	³
SD3	Pulse Width Low	t_{SDCKL}	0.45	0.55	SD_CLK	³
SD4	Address, $\overline{SD_CKE}$, $\overline{SD_CAS}$, $\overline{SD_RAS}$, $\overline{SD_WE}$, SD_BA, SD_CS[1:0] - Output Valid	$t_{SDCHACV}$	—	$0.5 \times SD_CLK + 1.0$	ns	
SD5	Address, $\overline{SD_CKE}$, $\overline{SD_CAS}$, $\overline{SD_RAS}$, $\overline{SD_WE}$, SD_BA, SD_CS[1:0] - Output Hold	$t_{SDCHACI}$	2.0	—	ns	
SD6	SD_SDR_DQS Output Valid	t_{DQSOV}	—	Self timed	ns	⁴
SD7	SD_DQS[3:2] input setup relative to SD_CLK	$t_{DQVSDCH}$	$0.25 \times SD_CLK$	$0.40 \times SD_CLK$	ns	⁵

Table 14. SDR Timing Specifications (continued)

Num	Characteristic	Symbol	Min	Max	Unit	Notes
SD8	SD_DQS[3:2] input hold relative to SD_CLK	$t_{DQISDCH}$	Does not apply. $0.5 \times SD_CLK$ fixed width.			⁶
SD9	Data (D[31:0]) Input Setup relative to SD_CLK (reference only)	$t_{DVS DCH}$	$0.25 \times SD_CLK$	—	ns	⁷
SD10	Data Input Hold relative to SD_CLK (reference only)	t_{DISDCH}	1.0	—	ns	
SD11	Data (D[31:0]) and Data Mask (SD_DQM[3:0]) Output Valid	$t_{SDCHDMV}$	—	$0.5 \times SD_CLK + 2$	ns	
SD12	Data (D[31:0]) and Data Mask (SD_DQM[3:0]) Output Hold	$t_{SDCHDMI}$	1.5	—	ns	

- ¹ The device supports same frequency of operation for both FlexBus and SDRAM clock operates as that of the internal bus clock. Please see the PLL chapter of the device reference manual for more information on setting the SDRAM clock rate.
- ² SD_CLK is one SDRAM clock in ns.
- ³ Pulse width high plus pulse width low cannot exceed min and max clock period.
- ⁴ SD_SDR_DQS is designed to pulse 0.25 clock before the rising edge of the memory clock. This is a guideline only. Subtle variation from this guideline is expected. SD_SDR_DQS will only pulse during a read cycle and one pulse will occur for each data beat.
- ⁵ SD_DQS is designed to pulse 0.25 clock before the rising edge of the memory clock. This spec is a guideline only. Subtle variation from this guideline is expected. SD_DQS will only pulse during a read cycle and one pulse will occur for each data beat.
- ⁶ The SD_DQS pulse is designed to be 0.5 clock in width. The timing of the rising edge is most important. The falling edge does not affect the memory controller.
- ⁷ Since a read cycle in SDR mode still uses the DQS circuit within the device, it is critical that the data valid window be centered 1/4 clk after the rising edge of DQS. Ensuring that this happens will result in successful SDR reads. The input setup spec is provided as guidance.

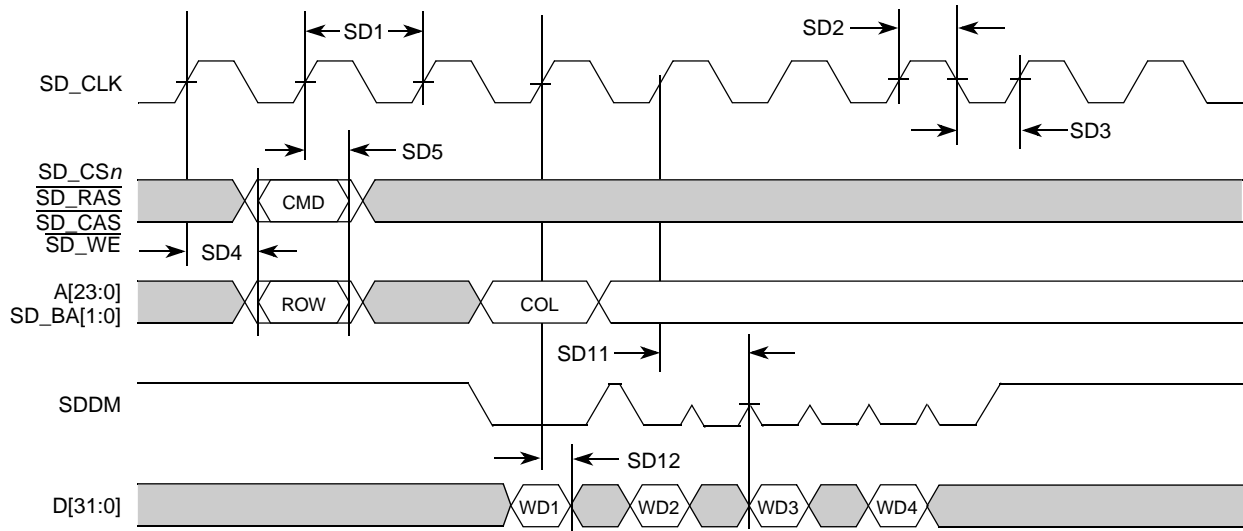

Figure 11. SDR Write Timing

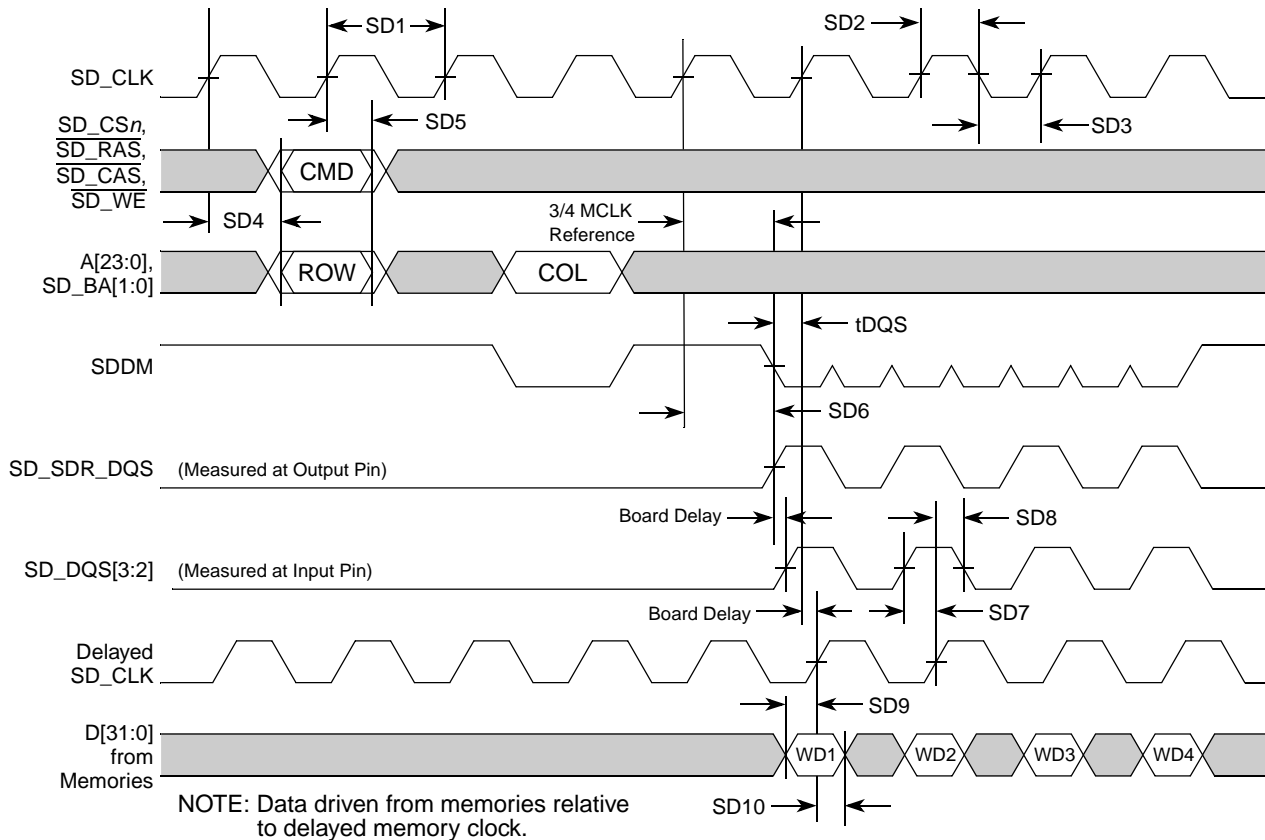

Figure 12. SDR Read Timing

5.7.2.2 DDR SDRAM AC Timing Specifications

When using the SDRAM controller in DDR mode, the following timing numbers must be followed to properly latch or drive data onto the memory bus. All timing numbers are relative to the two DQS byte lanes.

Table 15. DDR Timing Specifications

Num	Characteristic	Symbol	Min	Max	Unit	Notes
	Frequency of Operation	t_{DDCK}	60	83.33	MHz	1
DD1	Clock Period	t_{DDSK}	12.0	16.67	ns	2
DD2	Pulse Width High	t_{DDCKH}	0.45	0.55	SD_CLK	3
DD3	Pulse Width Low	t_{DDCKL}	0.45	0.55	SD_CLK	3
DD4	Address, $\overline{SD_CKE}$, $\overline{SD_CAS}$, $\overline{SD_RAS}$, $\overline{SD_WE}$, $\overline{SD_CS}[1:0]$ - Output Valid	$t_{SDCHACV}$	—	$0.5 \times SD_CLK + 1.0$	ns	4
DD5	Address, $\overline{SD_CKE}$, $\overline{SD_CAS}$, $\overline{SD_RAS}$, $\overline{SD_WE}$, $\overline{SD_CS}[1:0]$ - Output Hold	$t_{SDCHACI}$	2.0	—	ns	
DD6	Write Command to first DQS Latching Transition	t_{CMDVDQ}	—	1.25	SD_CLK	
DD7	Data and Data Mask Output Setup (DQ→DQS) Relative to DQS (DDR Write Mode)	t_{DQDMV}	1.5	—	ns	5 6

Table 15. DDR Timing Specifications (continued)

Num	Characteristic	Symbol	Min	Max	Unit	Notes
DD8	Data and Data Mask Output Hold (DQS→DQ) Relative to DQS (DDR Write Mode)	t_{DQDMI}	1.0	—	ns	⁷
DD9	Input Data Skew Relative to DQS (Input Setup)	t_{DQDQ}	—	1	ns	⁸
DD10	Input Data Hold Relative to DQS	t_{DIDQ}	$0.25 \times SD_CLK$ + 0.5ns	—	ns	⁹
DD11	DQS falling edge from SDCLK rising (output hold time)	$t_{DQLSDCH}$	0.5	—	ns	

- ¹ The frequency of operation is either 2x or 4x the FB_CLK frequency of operation. FlexBus and SDRAM clock operate at the same frequency as the internal bus clock.
- ² SD_CLK is one SDRAM clock in ns.
- ³ Pulse-width high plus pulse-width low cannot exceed minimum or maximum clock period.
- ⁴ Command output valid should be one-half the memory bus clock (SD_CLK) plus some minor adjustments for process, temperature, and voltage variations.
- ⁵ This specification relates to the required input setup time of today's DDR memories. The device's output setup should be larger than the input setup of the DDR memories. If it is not larger, then the input setup on the memory will be in violation. MEM_DATA[31:24] is relative to MEM_DQS[3], MEM_DATA[23:16] is relative to MEM_DQS[2], MEM_DATA[15:8] is relative to MEM_DQS[1], and MEM_DATA[7:0] is relative MEM_DQS[0].
- ⁶ The first data beat will be valid before the first rising edge of DQS and after the DQS write preamble. The remaining data beats will be valid for each subsequent DQS edge.
- ⁷ This specification relates to the required hold time of today's DDR memories. MEM_DATA[31:24] is relative to MEM_DQS[3], MEM_DATA[23:16] is relative to MEM_DQS[2], MEM_DATA[15:8] is relative to MEM_DQS[1], and MEM_DATA[7:0] is relative MEM_DQS[0].
- ⁸ Data input skew is derived from each DQS clock edge. It begins with a DQS transition and ends when the last data line becomes valid. This input skew must include DDR memory output skew and system-level board skew (due to routing or other factors).
- ⁹ Data input hold is derived from each DQS clock edge. It begins with a DQS transition and ends when the first data line becomes invalid.

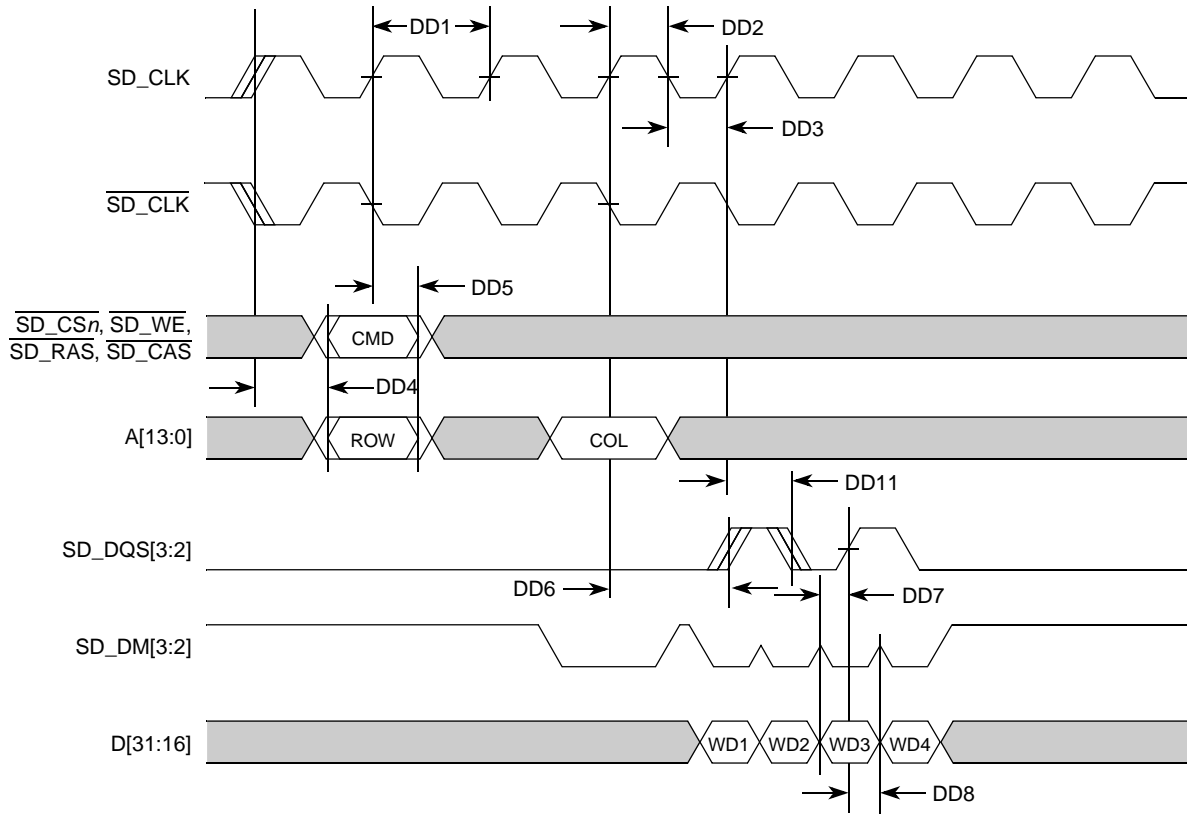

Figure 13. DDR Write Timing

Electrical Characteristics

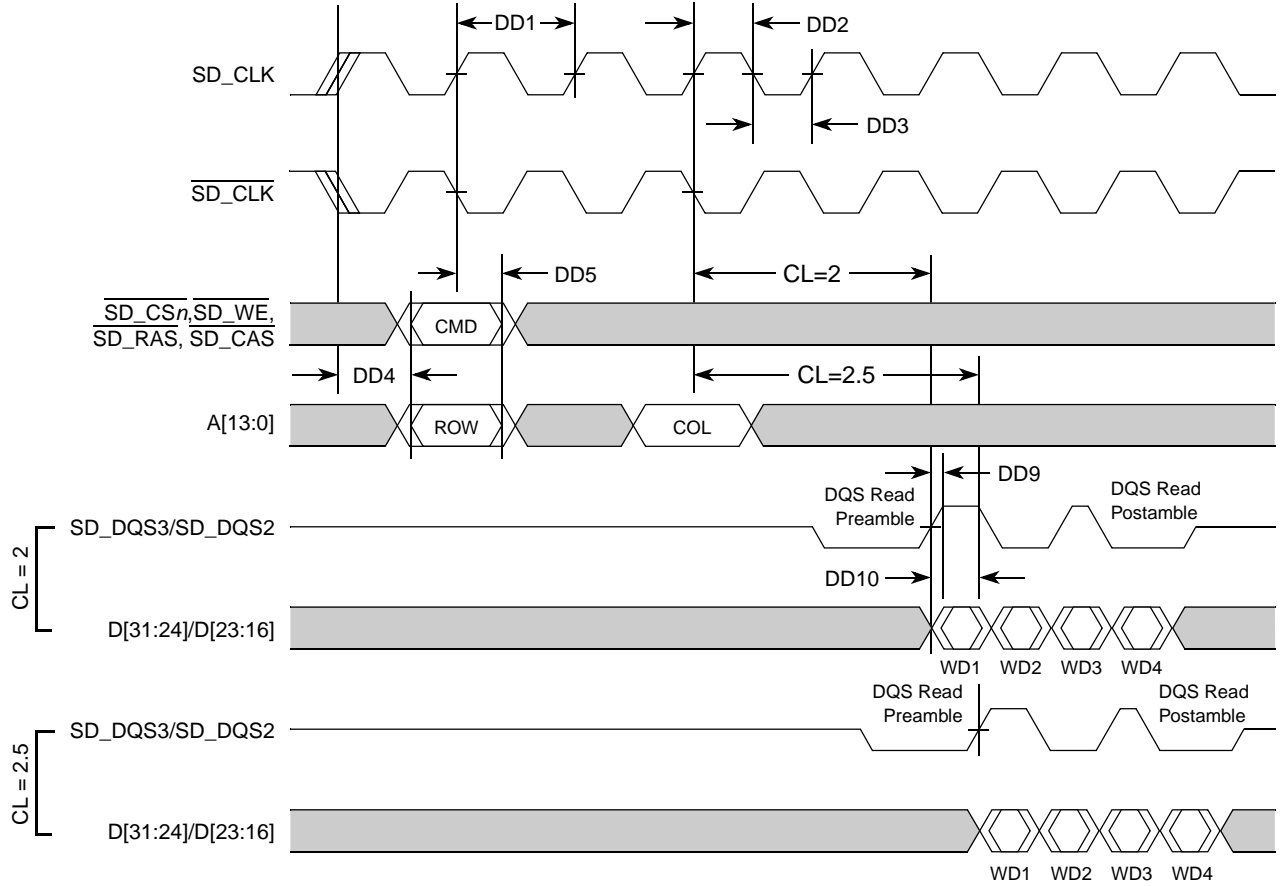

Figure 14. DDR Read Timing

Table 16. DDR Clock Crossover Specifications

Symbol	Characteristic	Min	Max	Unit
V_{MP}	Clock output mid-point voltage	1.05	1.45	V
V_{OUT}	Clock output voltage level	-0.3	$SD_VDD + 0.3$	V
V_{ID}	Clock output differential voltage (peak to peak swing)	0.7	$SD_VDD + 0.6$	V
V_{IX}	Clock crossing point voltage ¹	1.05	1.45	V

¹ The clock crossover voltage is only guaranteed when using the highest drive strength option for the SDCLK[1:0] and SDCLK[1:0] signals.

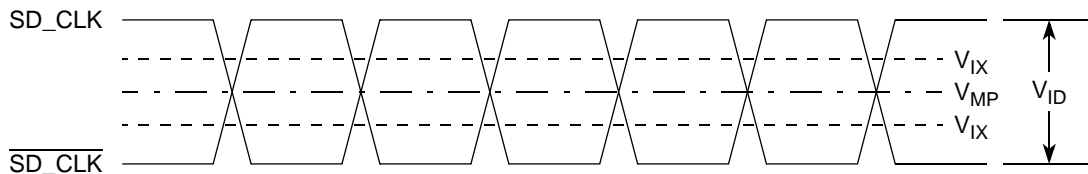

Figure 15. SD_CLK and $\overline{SD_CLK}$ Crossover Timing

5.8 General Purpose I/O Timing

Table 17. GPIO Timing¹

Num	Characteristic	Symbol	Min	Max	Unit
G1	FB_CLK High to GPIO Output Valid	t_{CHPOV}	—	10	ns
G2	FB_CLK High to GPIO Output Invalid	t_{CHPOI}	1.5	—	ns
G3	GPIO Input Valid to FB_CLK High	t_{PVCH}	9	—	ns
G4	FB_CLK High to GPIO Input Invalid	t_{CHPI}	1.5	—	ns

¹ These general purpose specifications apply to the following signals: \overline{IRQn} , all UART signals, FlexCAN signals, PWM signals, \overline{DACKn} and \overline{DREQn} , and all signals configured as GPIO.

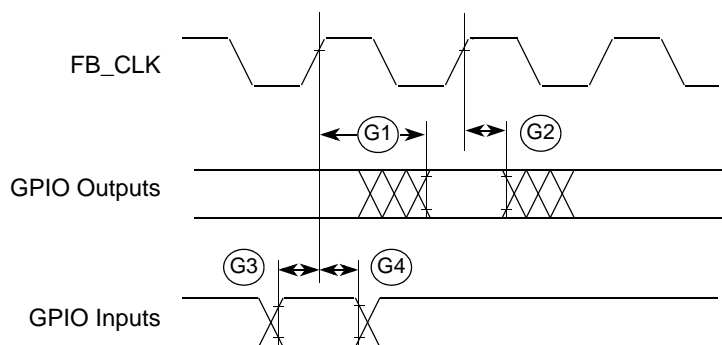

Figure 16. GPIO Timing

5.9 Reset and Configuration Override Timing

Table 18. Reset and Configuration Override Timing

Num	Characteristic	Symbol	Min	Max	Unit
R1	\overline{RESET} Input valid to FB_CLK High	t_{RVCH}	9	—	ns
R2	FB_CLK High to \overline{RESET} Input invalid	t_{CHRI}	1.5	—	ns
R3	\overline{RESET} Input valid Time ¹	t_{RIVT}	5	—	t_{CYC}
R4	FB_CLK High to \overline{RSTOUT} Valid	t_{CHROV}	—	10	ns
R5	\overline{RSTOUT} valid to Config. Overrides valid	t_{ROVCV}	0	—	ns
R6	Configuration Override Setup Time to \overline{RSTOUT} invalid	t_{COS}	20	—	t_{CYC}
R7	Configuration Override Hold Time after \overline{RSTOUT} invalid	t_{COH}	0	—	ns
R8	\overline{RSTOUT} invalid to Configuration Override High Impedance	t_{ROICZ}	—	1	t_{CYC}

¹ During low power STOP, the synchronizers for the \overline{RESET} input are bypassed and \overline{RESET} is asserted asynchronously to the system. Thus, \overline{RESET} must be held a minimum of 100 ns.

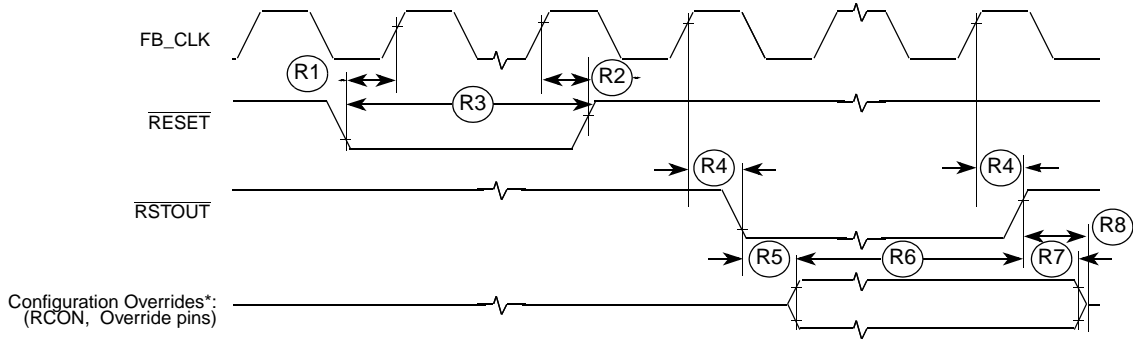

Figure 17. RESET and Configuration Override Timing

NOTE

Refer to the CCM chapter of the *MCF52277 Reference Manual* for more information.

5.10 LCD Controller Timing Specifications

This sections lists the timing specifications for the LCD Controller.

Table 19. LCD_LSCLK Timing

Num	Characteristic	Min	Max	Unit
T1	LCD_LSCLK Period	25	2000	ns
T2	Pixel data setup time	11	—	ns
T3	Pixel data up time	11	—	ns

Note: The pixel clock is equal to LCD_LSCLK / (PCD + 1). When it is in CSTN, TFT, or monochrome mode with bus width = 1, LCD_LSCLK is equal to the pixel clock. When it is in monochrome with other bus width settings, LCD_LSCLK is equal to the pixel clock divided by bus width. The polarity of LCD_LSCLK and LCD_D signals can also be programmed.

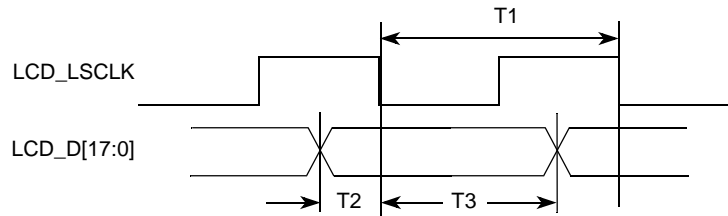

Figure 18. LCD_LSCLK to LCD_D[17:0] timing diagram

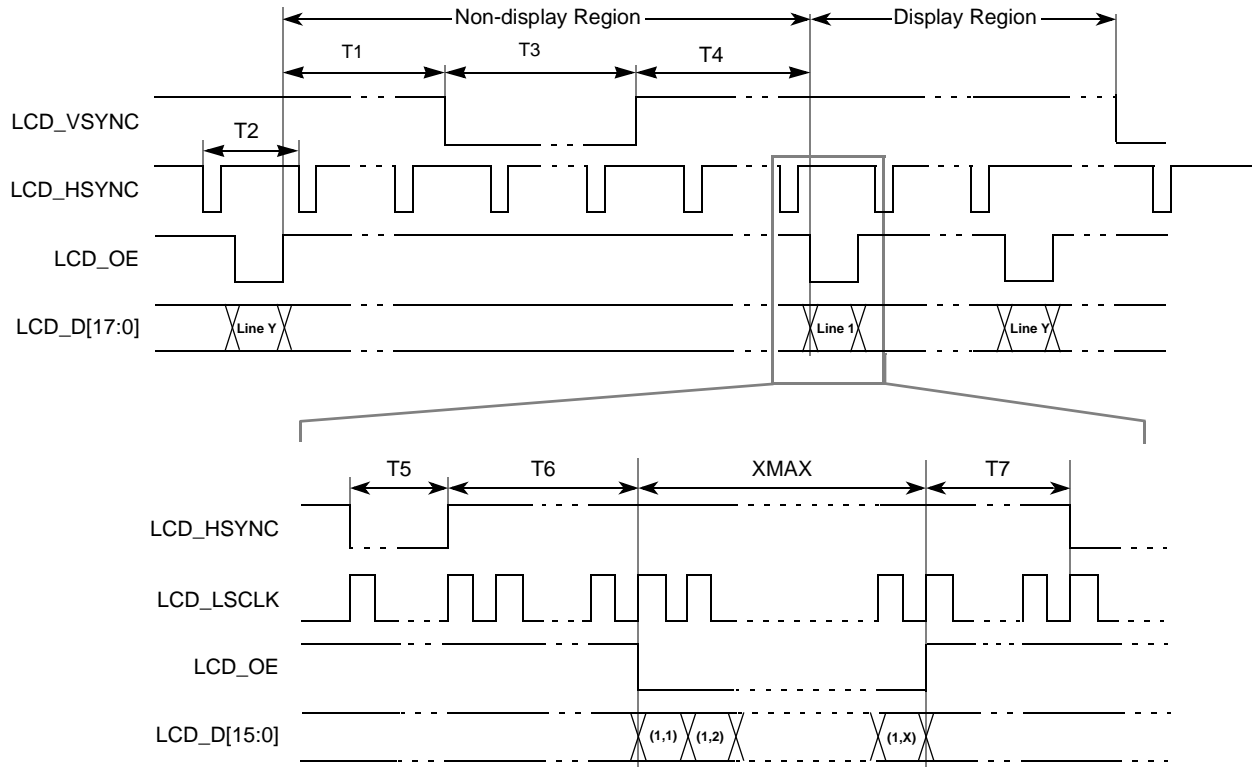

Figure 19. 4/8/12/16/18 Bit/Pixel TFT Color Mode Panel Timing

Table 20. 4/8/12/16/18 Bit/Pixel TFT Color Mode Panel Timing

Num	Characteristic	Min	Value	Unit
T1	End of LCD_OE to beginning of LCD_VSYNC	$T5 + T6 + T7 - 1$	$(VWAIT1 \times T2) + T5 + T6 + T7 - 1$	Ts
T2	LCD_VSYNC period	—	$XMAX + T5 + T6 + T7$	Ts
T3	LCD_VSYNC pulse width	T2	$VWIDTH \times T2$	Ts
T4	End of LCD_VSYNC to beginning of LCD_OE	1	$(VWAIT2 \times T2) + 1$	Ts
T5	LCD_HSYNC pulse width	1	$HWIDTH + 1$	Ts
T6	End of LCD_HSYNC to beginning to LCD_OE	3	$HWAIT2 + 3$	Ts
T7	End of LCD_OE to beginning of LCD_HSYNC	1	$HWAIT1 + 1$	Ts

Note: Ts is the LCD_LSCLK period. LCD_VSYNC, LCD_HSYNC, and LCD_OE can be programmed as active high or active low. In Figure 19, all 3 signals are active low. LCD_LSCLK can be programmed to be deactivated during the LCD_VSYNC pulse or the LCD_OE deassertion period. In Figure 19, LCD_LSCLK is always active.

Note: XMAX is defined in number of pixels in one line.

Electrical Characteristics

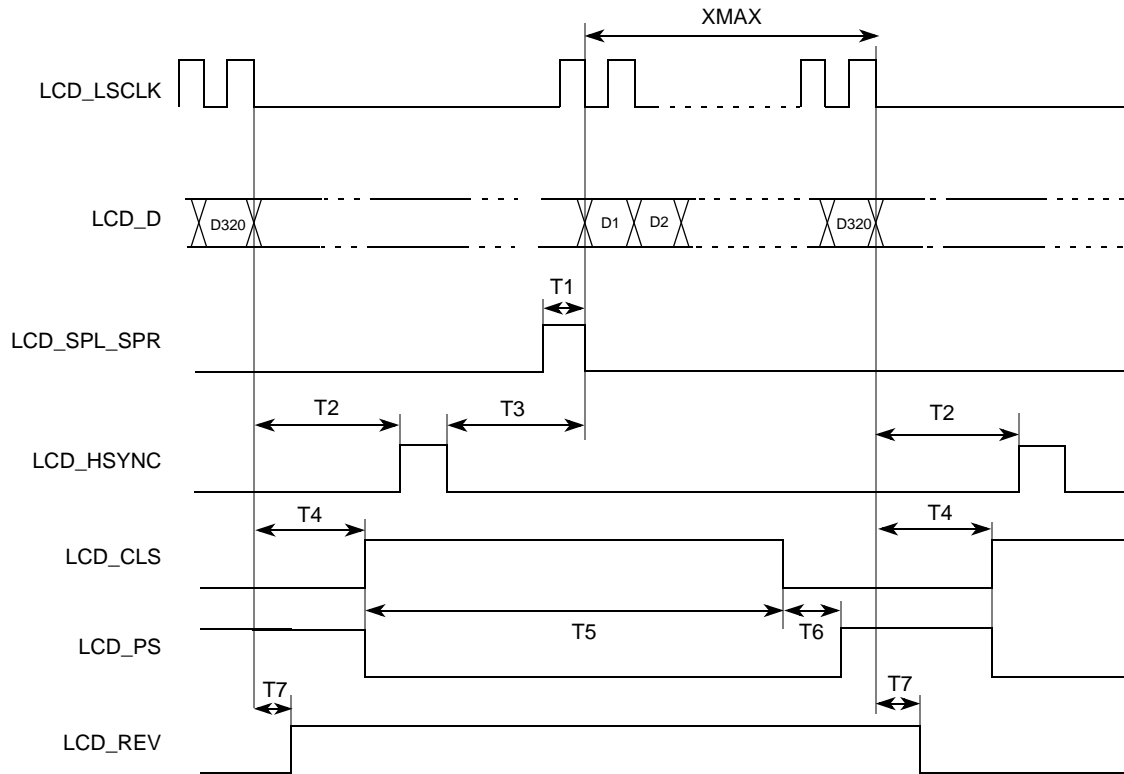

Figure 20. Sharp TFT Panel Timing

Table 21. Sharp TFT Panel Timing

Num	Characteristic	Min	Value	Unit
T1	LCD_SPL/LCD_SPR pulse width	—	1	Ts
T2	End of LCD_D of line to beginning of LCD_HSYNC	1	HWAIT1+1	Ts
T3	End of LCD_HSYNC to beginning of LCD_D of line	4	HWAIT2 + 4	Ts
T4	LCD_CLS rise delay from end of LCD_D of line	3	CLS_RISE_DELAY+1	Ts
T5	LCD_CLS pulse width	1	CLS_HI_WIDTH+1	Ts
T6	LCD_PS rise delay from LCD_CLS negation	0	PS_RISE_DELAY	Ts
T7	LCD_REV toggle delay from last LCD_D of line	1	REV_TOGGLE_DELAY+1	Ts

Note: Falling of LCD_SPL/LCD_SPR aligns with first LCD_D of line.

Note: Falling of LCD_PS aligns with rising edge of LCD_CLS.

Note: LCD_REV toggles in every LCD_HSYN period.

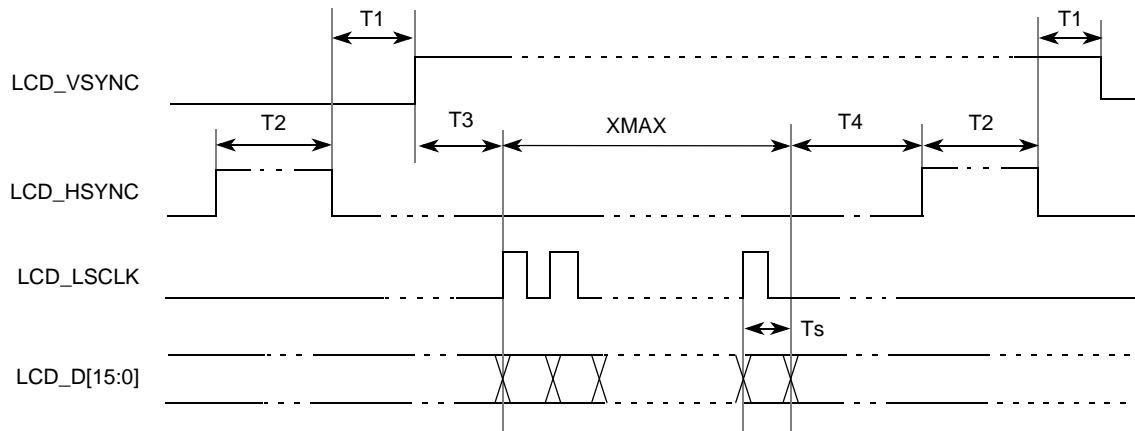

Figure 21. Non-TFT Mode Panel Timing

Table 22. Non-TFT Mode Panel Timing

Num	Characteristic	Min	Value	Unit
T1	LCD_HSYNC to LCD_VSYNC delay	2	HWAIT2 + 2	Tpix
T2	LCD_HSYNC pulse width	1	HWIDTH + 1	Tpix
T3	LCD_VSYNC to LCD_LSCLK	—	$0 \leq T3 \leq Ts$	—
T4	LCD_LSCLK to LCD_HSYNC	1	HWAIT1 + 1	Tpix

Note: Ts is the LCD_LSCLK period while Tpix is the pixel clock period. LCD_VSYNC, LCD_HSYNC, and LCD_LSCLK can be programmed as active high or active low. In Figure 21, all these 3 signals are active high. When it is in CSTN mode or monochrome mode with bus width = 1, $T3 = Tpix = Ts$. When it is in monochrome mode with bus width = 2, 4 and 8, $T3 = 1, 2$ and $4 Tpix$ respectively.

5.11 USB On-The-Go Specifications

The MCF5227x device is compliant with industry standard USB 2.0 specification.

Table 23. USB On-Chip Transceiver DC Characteristics

Characteristic	Condition	Symbol	Min	Typ	Max	Unit
Input High	Driven	V_{IH}	2.0	—	—	V
Input Low		V_{IL}	—	—	0.8	V
Input Differential	(DP – DM)	V_{ID}	200	—	00	mV
Differential Common Mode Range		V_{CM}	0.8	—	2.5	V
Single Ended Receive Threshold		V_{SETHR}	0.8	—	2.0	V
Single Ended Receive Hysteresis		V_{SEHYS}	—	400	—	mV
Output High	Driven	V_{OH}	0.0	—	300	mV
Output Low	Driven	V_{OL}	2.8	—	2.0	V
Differential Output Crossover	DP = DM	V_{CRS}	1.3	—	2.0	V

Table 23. USB On-Chip Transceiver DC Characteristics (continued)

Characteristic	Condition	Symbol	Min	Typ	Max	Unit
P side Impedance	Driven	Z_P	6.25	8.25	11.25	Ω
M side Impedance	Driven	Z_M	6.25	8.25	11.25	Ω
Impedance Matching P/M		Z_{Matching}	—	0.17	0.23	Ω
Pulldown Resistance ¹		R_{PD}	30k	50k	70k	Ω

¹ The pulldown resistors are included to provide a method to keep DP and DM signals in a known quiescent state if desired when the USB port is not being used or when the USB cable is not connected. These on-chip resistors should not be used to provide the 15-k Ω host-mode pulldowns called for in Chapter 7 of the USB Specification, Rev. 1.1 or Rev. 2.0.

Table 24. USB On-Chip Transceiver Full Speed AC Characteristics

Characteristic	Condition	Symbol	Min	Typ	Max	Unit
Rise Time	10–90%	t_{LH}	7	11	17.5	ns
Fall Time	90–10%	t_{HL}	7	11	17.5	ns
Rise/Fall Matching	—	$\frac{t_{LH}}{t_{HL}}$ Matching	20	40	60	ps
Rise/Fall Matching, DP and DM	—	$\frac{t_{LH}}{t_{HL}}$ Pad-to-Pad	330	360	640	ps
Time Skew Between DP and DM	—	t_{SKE}	100	140	210	ps

Table 25. USB On-Chip Transceiver Low Speed AC Characteristics

Characteristic	Condition	Symbol	Min	Typ	Max	Unit
Rise Time	10–90%	t_{LH}	75	—	300	ns
Fall Time	90–10%	t_{HL}	75	—	300	ns
Rise/Fall Matching	$\frac{t_{LH}}{t_{HL}}$	$\frac{t_{LH}}{t_{HL}}$ Matching	80	—	125	%

5.12 SSI Timing Specifications

This section provides the AC timings for the SSI in master (clocks driven) and slave modes (clocks input). All timings are given for non-inverted serial clock polarity (SSI_TCR[TSCPK] = 0, SSI_RCR[RSCKP] = 0) and a non-inverted frame sync (SSI_TCR[TFSI] = 0, SSI_RCR[RFSI] = 0). If the polarity of the clock and/or the frame sync have been inverted, all the timings remain valid by inverting the clock signal (SSI_BCLK) and/or the frame sync (SSI_FS) shown in the figures below.

Table 26. SSI Timing—Master Modes¹

Num	Characteristic	Symbol	Min	Max	Unit	Notes
S1	SSI_MCLK cycle time	t_{MCLK}	$4 \times 1/f_{SYS}$	—	ns	²
S2	SSI_MCLK pulse width high / low		45%	55%	t_{MCLK}	
S3	SSI_BCLK cycle time	t_{BCLK}	$4 \times 1/f_{SYS}$	—	ns	³
S4	SSI_BCLK pulse width		45%	55%	t_{BCLK}	

Table 26. SSI Timing—Master Modes¹ (continued)

Num	Characteristic	Symbol	Min	Max	Unit	Notes
S5	SSI_BCLK to SSI_FS output valid		—	10	ns	
S6	SSI_BCLK to SSI_FS output invalid		0	—	ns	
S7	SSI_BCLK to SSI_TXD valid		—	10	ns	
S8	SSI_BCLK to SSI_TXD invalid / high impedance		0	—	ns	
S9	SSI_RXD / SSI_FS input setup before SSI_BCLK		10	—	ns	
S10	SSI_RXD / SSI_FS input hold after SSI_BCLK		0	—	ns	

¹ All timings specified with a capacitive load of 25pF.

² SSI_MCLK can be generated from SSI_CLKIN or a divided version of the internal system clock (SYSCLK).

³ SSI_BCLK can be derived from SSI_CLKIN or a divided version of SYSCLK. If the SYSCLK is used, the minimum divider is 6. If the SSI_CLKIN input is used, the programmable dividers must be set to ensure that SSI_BCLK does not exceed $4 \times f_{\text{SYS}}$.

Table 27. SSI Timing—Slave Modes¹

Num	Characteristic	Symbol	Min	Max	Unit	Notes
S11	SSI_BCLK cycle time	t_{BCLK}	$4 \times 1/f_{\text{SYS}}$	—	ns	
S12	SSI_BCLK pulse width high / low		45%	55%	t_{BCLK}	
S13	SSI_FS input setup before SSI_BCLK		10	—	ns	
S14	SSI_FS input hold after SSI_BCLK		2	—	ns	
S15	SSI_BCLK to SSI_TXD / SSI_FS output valid		—	10	ns	
S16	SSI_BCLK to SSI_TXD / SSI_FS output invalid / high impedance		0	—	ns	
S17	SSI_RXD setup before SSI_BCLK		10	—	ns	
S18	SSI_RXD hold after SSI_BCLK		2	—	ns	

¹ All timings specified with a capacitive load of 25 pF.

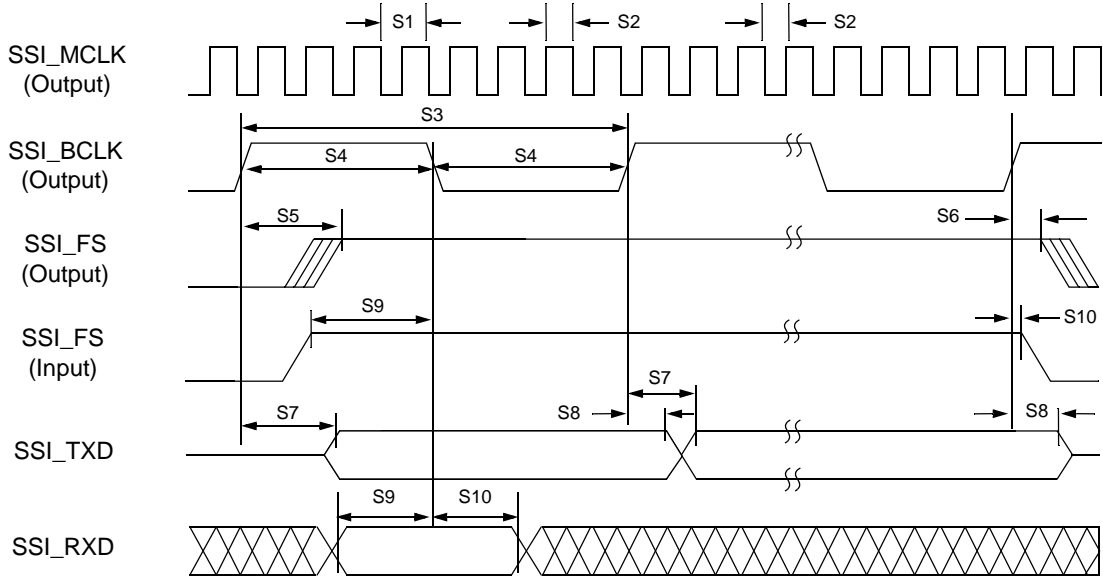

Figure 22. SSI Timing—Master Modes

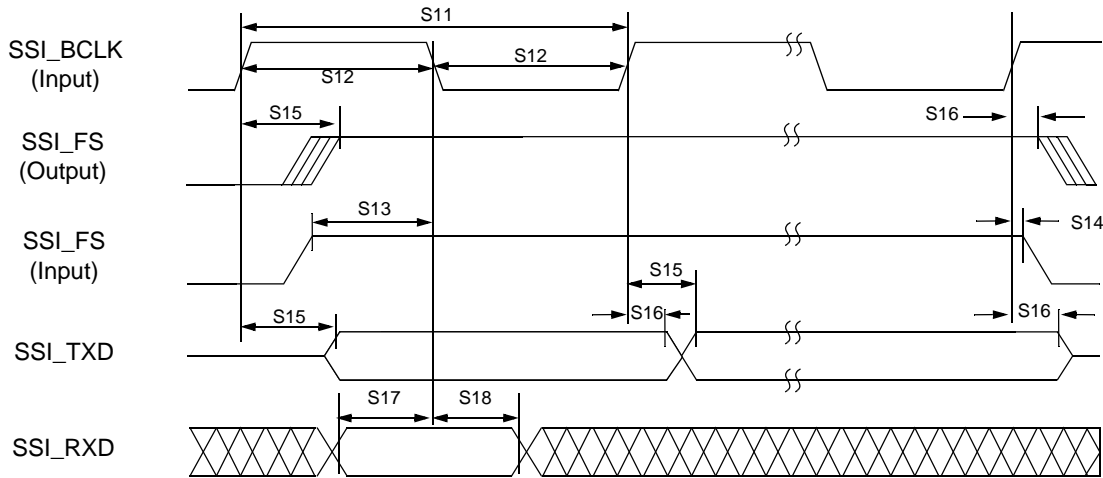

Figure 23. SSI Timing—Slave Modes

5.13 I²C Timing Specifications

Table 28 lists specifications for the I²C input timing parameters shown in Figure 24.

Table 28. I²C Input Timing Specifications between SCL and SDA

Num	Characteristic	Min	Max	Unit
I1	Start condition hold time	2	—	t _{cyc}
I2	Clock low period	8	—	t _{cyc}
I3	I2C_SCL/I2C_SDA rise time (V _{IL} = 0.5 V to V _{IH} = 2.4 V)	—	1	ms
I4	Data hold time	0	—	ns

Table 28. I²C Input Timing Specifications between SCL and SDA (continued)

Num	Characteristic	Min	Max	Unit
I5	I2C_SCL/I2C_SDA fall time ($V_{IH} = 2.4\text{ V}$ to $V_{IL} = 0.5\text{ V}$)	—	1	ms
I6	Clock high time	4	—	t_{cyc}
I7	Data setup time	0	—	ns
I8	Start condition setup time (for repeated start condition only)	2	—	t_{cyc}
I9	Stop condition setup time	2	—	t_{cyc}

Table 29 lists specifications for the I²C output timing parameters shown in Figure 24.

Table 29. I²C Output Timing Specifications between SCL and SDA

Num	Characteristic	Min	Max	Unit
I1 ¹	Start condition hold time	6	—	t_{cyc}
I2 ¹	Clock low period	10	—	t_{cyc}
I3 ²	I2C_SCL/I2C_SDA rise time ($V_{IL} = 0.5\text{ V}$ to $V_{IH} = 2.4\text{ V}$)	—	—	μs
I4 ¹	Data hold time	7	—	t_{cyc}
I5 ³	I2C_SCL/I2C_SDA fall time ($V_{IH} = 2.4\text{ V}$ to $V_{IL} = 0.5\text{ V}$)	—	3	ns
I6 ¹	Clock high time	10	—	t_{cyc}
I7 ¹	Data setup time	2	—	t_{cyc}
I8 ¹	Start condition setup time (for repeated start condition only)	20	—	t_{cyc}
I9 ¹	Stop condition setup time	10	—	t_{cyc}

¹ Output numbers depend on the value programmed into the IFDR; an IFDR programmed with the maximum frequency (IFDR = 0x20) results in minimum output timings as shown in Table 29. The I²C interface is designed to scale the actual data transition time to move it to the middle of the SCL low period. The actual position is affected by the prescale and division values programmed into the IFDR; however, the numbers given in Table 29 are minimum values.

² Because I2C_SCL and I2C_SDA are open-collector-type outputs, which the processor can only actively drive low, the time I2C_SCL or I2C_SDA take to reach a high level depends on external signal capacitance and pull-up resistor values.

³ Specified at a nominal 50-pF load.

Figure 24 shows timing for the values in Table 29 and Table 28.

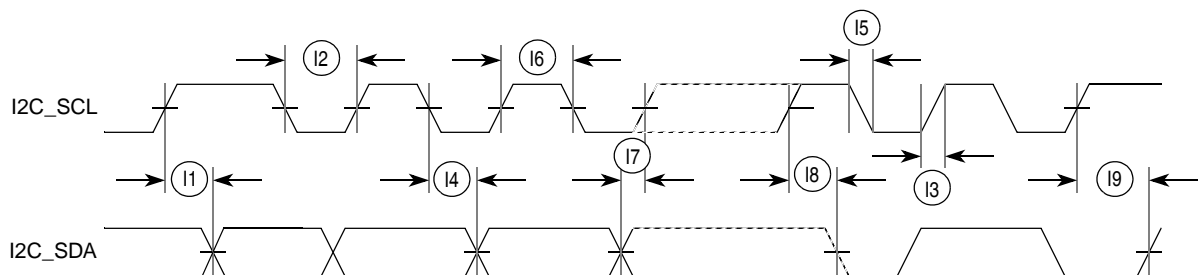
**Figure 24. I²C Input/Output Timings**

5.14 DMA Timer Timing Specifications

Table 30 lists timer module AC timings.

Table 30. Timer Module AC Timing Specifications

Num	Characteristic	Min	Max	Unit
T1	DT0IN / DT1IN / DT2IN / DT3IN cycle time	3	—	t _{CYC}
T2	DT0IN / DT1IN / DT2IN / DT3IN pulse width	1	—	t _{CYC}

5.15 DSPI Timing Specifications

The DMA Serial Peripheral Interface (DSPI) provides a synchronous serial bus with both master and slave operations. Many of the transfer attributes are programmable. Table 31 provides DSPI timing characteristics for classic SPI timing modes. Refer to the DSPI chapter of the *MCF52277 Reference Manual* for information on the modified transfer formats used for communicating with slower peripheral devices.

Table 31. DSPI Module AC Timing Specifications¹

Num	Characteristic	Symbol	Min	Max	Unit	Notes
DS1	DSPI_SCK Cycle Time	t _{SCK}	$4 \times 1/f_{SYS}$	—	ns	2
DS2	DSPI_SCK Duty Cycle	—	$(t_{SCK} \div 2) - 2.0$	$(t_{SCK} \div 2) + 2.0$	ns	
Master Mode						
DS3	DSPI_PCS _n to DSPI_SCK delay	t _{CSC}	$(2 \times 1/f_{SYS}) - 2.0$	—	ns	3
DS4	DSPI_SCK to DSPI_PCS _n delay	t _{ASC}	$(2 \times 1/f_{SYS}) - 3.0$	—	ns	4
DS5	DSPI_SCK to DSPI_SOUT valid	—	—	5	ns	
DS6	DSPI_SCK to DSPI_SOUT invalid	—	-5	—	ns	
DS7	DSPI_SIN to DSPI_SCK input setup	—	9	—	ns	
DS8	DSPI_SCK to DSPI_SIN input hold	—	0	—	ns	
Slave Mode						
DS9	DSPI_SCK to DSPI_SOUT valid	—	—	4	ns	
DS10	DSPI_SCK to DSPI_SOUT invalid	—	0	—	ns	
DS11	DSPI_SIN to DSPI_SCK input setup	—	2	—	ns	
DS12	DSPI_SCK to DSPI_SIN input hold	—	7	—	ns	
DS13	$\overline{\text{DSPI_SS}}$ active to DSPI_SOUT driven	—	—	20	ns	
DS14	$\overline{\text{DSPI_SS}}$ inactive to DSPI_SOUT not driven	—	—	18	ns	

¹ Timings shown are for DMCR[MTFE] = 0 (classic SPI) and DCTAR_n[CPHA] = 0. Data is sampled on the DSPI_SIN pin on the odd-numbered DSPI_SCK edges and driven on the DSPI_SOUT pin on even-numbered DSPI edges.

² When in master mode, the baud rate is programmable in DCTAR_n[PBR] and DCTAR_n[BR].

³ The DSPI_PCS_n to DSPI_SCK delay is programmable in DCTAR_n[PCSSCK] and DCTAR_n[CSSCK].

⁴ The DSPI_SCK to DSPI_PCS_n delay is programmable in DCTAR_n[PASC] and DCTAR_n[ASC].

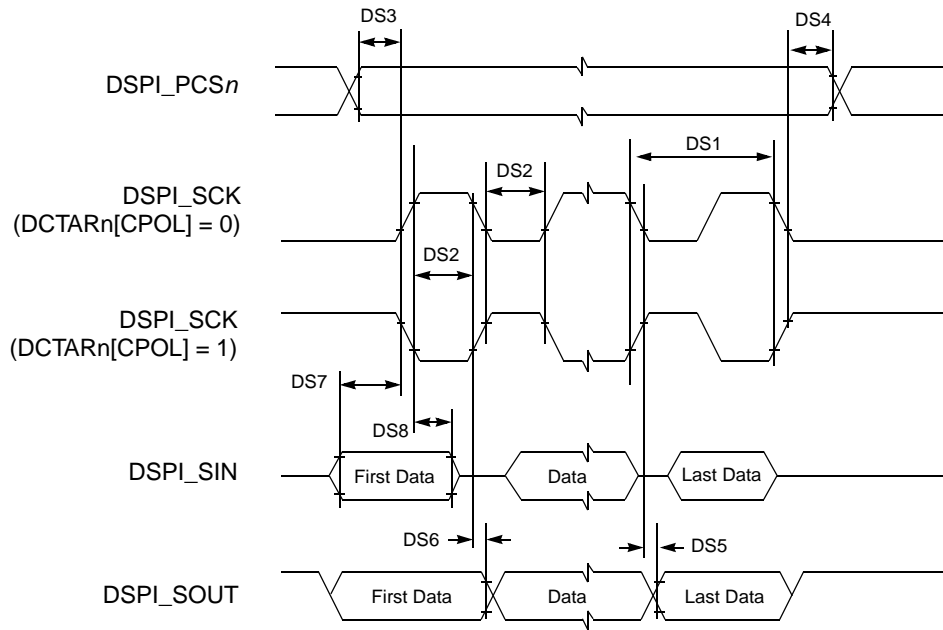

Figure 25. DSPI Classic SPI Timing—Master Mode

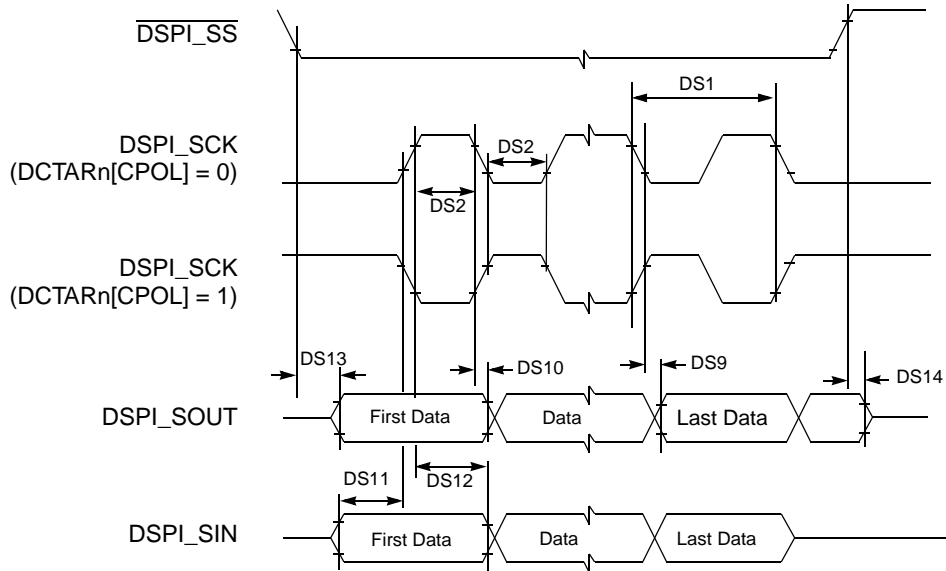

Figure 26. DSPI Classic SPI Timing—Slave Mode

5.16 SBF Timing Specifications

The Serial Boot Facility (SBF) provides a means to read configuration information and system boot code from a broad array of SPI-compatible EEPROMs, flashes, FRAMs, nVSRAMs, etc. [Table 32](#) provides the AC timing specifications for the SBF.

Table 32. SBF AC Timing Specifications

Num	Characteristic	Symbol	Min	Max	Unit	Notes
SB1	SBF_CK Cycle Time	t_{SBFCK}	30	—	ns	1
SB2	SBF_CK High/Low Time	—	30%	—	t_{SBFCK}	
SB3	$\overline{\text{SBF_CS}}$ to SBF_CK delay	—	$t_{\text{SBFCK}} - 2.0$	—	ns	
SB4	SBF_CK to $\overline{\text{SBF_CS}}$ delay	—	$t_{\text{SBFCK}} - 2.0$	—	ns	
SB5	SBF_CK to SBF_DO valid	—	—	12	ns	
SB6	SBF_CK to SBF_DO invalid	—	0	—	ns	
SB7	SBF_DI to SBF_SCK input setup	—	6	—	ns	
SB8	SBF_CK to SBF_DI input hold	—	0	—	ns	

¹ At reset, the SBF_CK cycle time is $t_{\text{REF}} \times 67$. The first byte of data read from the serial memory contains a divider value that is used to set the SBF_CK cycle time for the duration of the serial boot process.

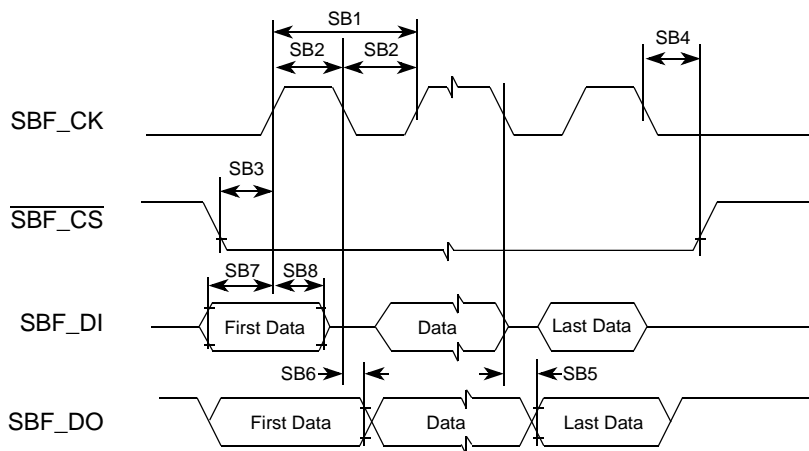

Figure 27. SBF Timing

5.17 JTAG and Boundary Scan Timing Specifications

Table 33. JTAG and Boundary Scan Timing

Num	Characteristic ¹	Symbol	Min	Max	Unit
J1	TCLK Frequency of Operation	f_{JCYC}	DC	1/4	$f_{\text{sys}/2}$
J2	TCLK Cycle Period	t_{JCYC}	4	—	t_{CYC}
J3	TCLK Clock Pulse Width	t_{JCW}	26	—	ns
J4	TCLK Rise and Fall Times	t_{JCRF}	0	3	ns
J5	Boundary Scan Input Data Setup Time to TCLK Rise	t_{BSDST}	4	—	ns
J6	Boundary Scan Input Data Hold Time after TCLK Rise	t_{BSDHT}	26	—	ns
J7	TCLK Low to Boundary Scan Output Data Valid	t_{BSDV}	0	33	ns
J8	TCLK Low to Boundary Scan Output High Z	t_{BSDZ}	0	33	ns

Table 33. JTAG and Boundary Scan Timing (continued)

Num	Characteristic ¹	Symbol	Min	Max	Unit
J9	TMS, TDI Input Data Setup Time to TCLK Rise	t_{TAPBST}	4	—	ns
J10	TMS, TDI Input Data Hold Time after TCLK Rise	t_{TAPBHT}	10	—	ns
J11	TCLK Low to TDO Data Valid	t_{TDODV}	0	26	ns
J12	TCLK Low to TDO High Z	t_{TDODZ}	0	8	ns
J13	\overline{TRST} Assert Time	t_{TRSTAT}	100	—	ns
J14	\overline{TRST} Setup Time (Negation) to TCLK High	t_{TRSTST}	10	—	ns

¹ JTAG_EN is expected to be a static signal. Hence, specific timing is not associated with it.

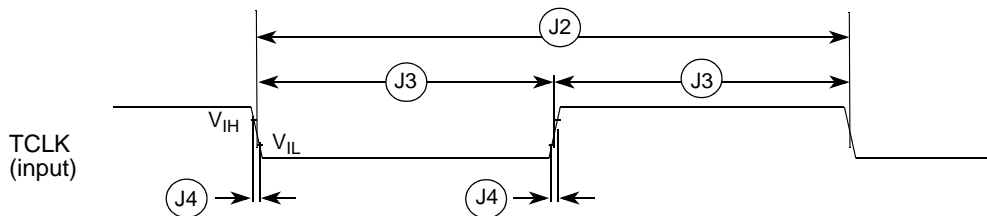

Figure 28. Test Clock Input Timing

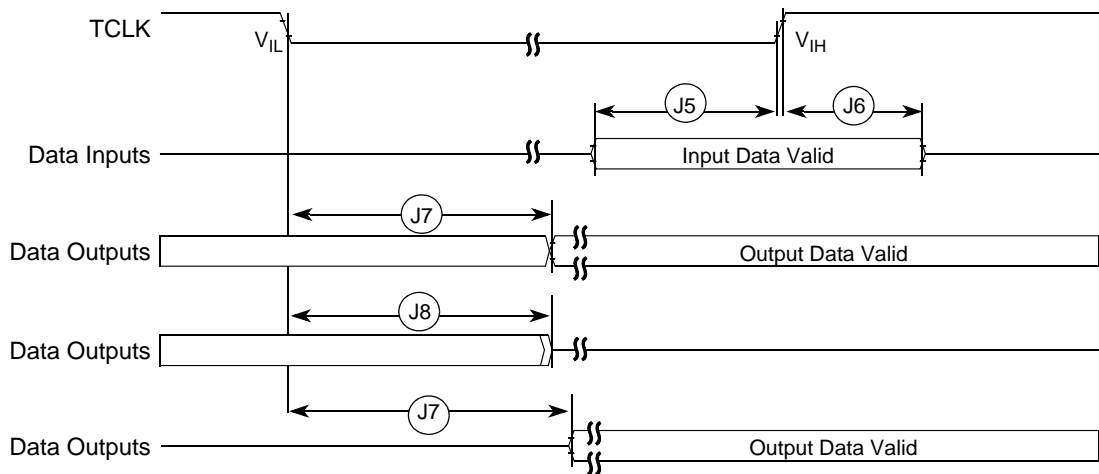

Figure 29. Boundary Scan (JTAG) Timing

Electrical Characteristics

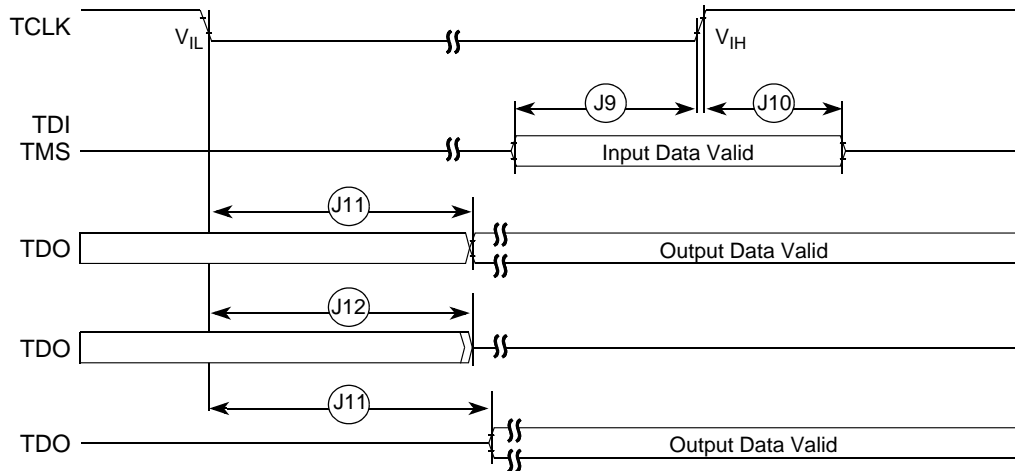

Figure 30. Test Access Port Timing

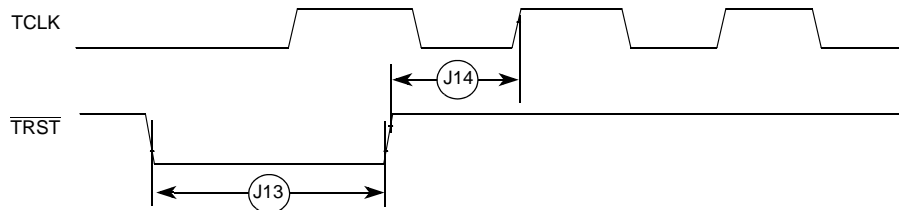

Figure 31. $\overline{\text{TRST}}$ Timing

5.18 Debug AC Timing Specifications

Table 34 lists specifications for the debug AC timing parameters shown in Figure 32.

Table 34. Debug AC Timing Specification

Num	Characteristic	Min	Max	Units
D0	PSTCLK cycle time	1	1	$1/f_{\text{SYS}}$
D1	PSTCLK rising to PSTDDATA valid	—	3.0	ns
D2	PSTCLK rising to PSTDDATA invalid	1.5	—	ns
D3	DSI-to-DSCLK setup	1	—	PSTCLK
D4 ¹	DSCLK-to-DSO hold	4	—	PSTCLK
D5	DSCLK cycle time	5	—	PSTCLK
D6	BKPT assertion time	1	—	PSTCLK

¹ DSCLK and DSI are synchronized internally. D4 is measured from the synchronized DSCLK input relative to the rising edge of PSTCLK.

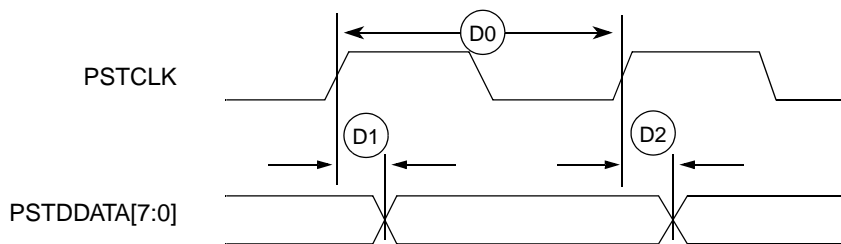

Figure 32. Real-Time Trace AC Timing

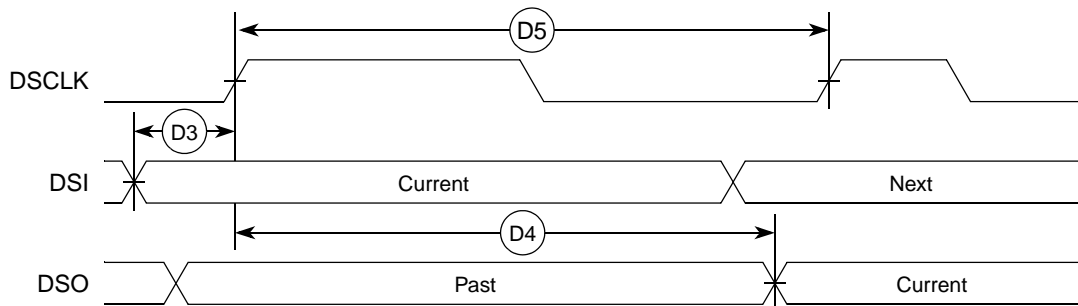

Figure 33. BDM Serial Port AC Timing

6 Package Information

The latest package outline drawings are available on the product summary pages on our web site: <http://www.freescale.com/coldfire>. The following table lists the case outline numbers per device. Use these numbers in the web page's keyword search engine to find the latest package outline drawings.

Table 35. Package Information

Device	Package Type	Mask Set	Revision	Case Outline Numbers
MCF52274	176 LQFP	All	All	98ASS23479W
MCF52277	196 MAPBGA	M26H	1.1	98ASH98061A
		2M26H, 3M26H	1.2–1.3	98ARH98390A

7 Product Documentation

Documentation is available from a local Freescale distributor, a Freescale sales office, the Freescale Literature Distribution Center, or through the Freescale world-wide web address at <http://www.freescale.com/coldfire>.

8 Revision History

Table 36 summarizes revisions to this document.

Table 36. MCF52277 Data Sheet Revision History

Rev. No.	Date of Release	Summary of Changes
3	02/2008	Initial public revision.
4	05/2008	Corrected MCF52274 order number from MCF52274CAB120 to MCF52274CLU120 in Table 2
5	07/2008	Corrected MCF52277CVM166 part number to MCF52277CVM160 in Table 2 . Although, this device has a maximum rated frequency of 166.67 MHz.
6	07/2008	Added data to Section 3.5, "Power Consumption Specifications."
7	02/2009	<p>Changed document type from Data Sheet: Advance Information to Data Sheet: Technical Data and corresponding footnote on first page</p> <p>Replaced t_{SYS} with $1/f_{SYS}$ throughout</p> <p>Changed the following specs in Table 14 and Table 15:</p> <ul style="list-style-type: none"> • Minimum frequency of operation from TBD to 60MHz • Maximum clock period from TBD to 16.67 ns <p>Added RTC and Oscillator Supply Voltage specs to Table 7 and Table 10</p> <p>In Table 8:</p> <ul style="list-style-type: none"> • Updated thermal characteristics for the 196 MAPBGA package • Added thermal characteristics for the 176 LQFP package that were TBD <p>In Table 11:</p> <ul style="list-style-type: none"> • Corrected maximum crystal reference frequency range from 66.67 to 25 MHz • Added footnotes to maximum crystal and external reference frequency ranges • Changed minimum core/system and CLKOUT frequencies from TBD to 512 and 256 Hz, respectively. <p>In Table 12:</p> <ul style="list-style-type: none"> • Added Typical column • Removed Internal Reference Voltage spec as it isn't necessary • Moved Current Consumption specs from maximum column to typical column • Added INL and DNL specs that were TBD, and changed the unit footnote • Replaced Gain and Offset Error specs with Full-Scale and Zero-Scale Error • Removed Input Leakage Current and Input Current specs as they aren't necessary <p>Removed Gain Calculations section as it isn't necessary</p>
8	09/2009	In Table 35 , added case outline number for MCF52277 masks 2M26H and 3M26H

How to Reach Us:

Home Page:

www.freescale.com

Web Support:

<http://www.freescale.com/support>

USA/Europe or Locations Not Listed:

Freescale Semiconductor, Inc.
Technical Information Center, EL516
2100 East Elliot Road
Tempe, Arizona 85284
+1-800-521-6274 or +1-480-768-2130
www.freescale.com/support

Europe, Middle East, and Africa:

Freescale Halbleiter Deutschland GmbH
Technical Information Center
Schatzbogen 7
81829 Muenchen, Germany
+44 1296 380 456 (English)
+46 8 52200080 (English)
+49 89 92103 559 (German)
+33 1 69 35 48 48 (French)
www.freescale.com/support

Japan:

Freescale Semiconductor Japan Ltd.
Headquarters
ARCO Tower 15F
1-8-1, Shimo-Meguro, Meguro-ku,
Tokyo 153-0064
Japan
0120 191014 or +81 3 5437 9125
support.japan@freescale.com

Asia/Pacific:

Freescale Semiconductor Hong Kong Ltd.
Technical Information Center
2 Dai King Street
Tai Po Industrial Estate
Tai Po, N.T., Hong Kong
+800 2666 8080
support.asia@freescale.com

For Literature Requests Only:

Freescale Semiconductor Literature Distribution Center
P.O. Box 5405
Denver, Colorado 80217
1-800-441-2447 or 303-675-2140
Fax: 303-675-2150
LDCForFreescaleSemiconductor@hibbertgroup.com

Document Number: MCF52277

Rev. 8

09/2009

Information in this document is provided solely to enable system and software implementers to use Freescale Semiconductor products. There are no express or implied copyright licenses granted hereunder to design or fabricate any integrated circuits or integrated circuits based on the information in this document.

Freescale Semiconductor reserves the right to make changes without further notice to any products herein. Freescale Semiconductor makes no warranty, representation or guarantee regarding the suitability of its products for any particular purpose, nor does Freescale Semiconductor assume any liability arising out of the application or use of any product or circuit, and specifically disclaims any and all liability, including without limitation consequential or incidental damages. "Typical" parameters that may be provided in Freescale Semiconductor data sheets and/or specifications can and do vary in different applications and actual performance may vary over time. All operating parameters, including "Typicals", must be validated for each customer application by customer's technical experts. Freescale Semiconductor does not convey any license under its patent rights nor the rights of others. Freescale Semiconductor products are not designed, intended, or authorized for use as components in systems intended for surgical implant into the body, or other applications intended to support or sustain life, or for any other application in which the failure of the Freescale Semiconductor product could create a situation where personal injury or death may occur. Should Buyer purchase or use Freescale Semiconductor products for any such unintended or unauthorized application, Buyer shall indemnify and hold Freescale Semiconductor and its officers, employees, subsidiaries, affiliates, and distributors harmless against all claims, costs, damages, and expenses, and reasonable attorney fees arising out of, directly or indirectly, any claim of personal injury or death associated with such unintended or unauthorized use, even if such claim alleges that Freescale Semiconductor was negligent regarding the design or manufacture of the part.

RoHS-compliant and/or Pb-free versions of Freescale products have the functionality and electrical characteristics as their non-RoHS-compliant and/or non-Pb-free counterparts. For further information, see <http://www.freescale.com> or contact your Freescale sales representative.

For information on Freescale's Environmental Products program, go to <http://www.freescale.com/epp>.

Freescale™ and the Freescale logo are trademarks of Freescale Semiconductor, Inc. All other product or service names are the property of their respective owners.
© Freescale Semiconductor, Inc. 2009. All rights reserved.

