

Media Resistant Integrated Silicon Pressure Sensor for Measuring Absolute Pressure, On-Chip Signal Conditioned, Temperature Compensated and Calibrated

MPXHZ6116A Series

20 to 115 kPa (2.9 to 16.7 psi)
0.399 to 4.645 V Output

The MPXHZ6116A series pressure sensor integrates on-chip, bipolar op amp circuitry and thin film resistor networks to provide a high output signal and temperature compensation. The sensor's packaging has been designed to provide resistance to high humidity conditions as well as common automotive media. The small form factor and high reliability of on-chip integration make this sensor a logical and economical choice for the system designer.

The MPXHZ6116A series pressure sensor is a state-of-the-art, monolithic, signal conditioned sensor designed for a wide range of applications, but particularly those employing a microcontroller or microprocessor with A/D inputs. This piezoresistive transducer combines advanced micromachining techniques, thin-film metallization, and bipolar processing to provide an accurate, high level analog output signal that is proportional to the applied pressure.

Features

- Resistant to High Humidity and Common Automotive Media
- 1.43% Maximum Error over 0 to 85 °C
- Temperature Compensated from -40 °C to +125 °C
- Durable Thermoplastic (PPS) Surface Mount Package (SSOP)
- Ideally Suited for Microprocessor or Microcontroller-Based Systems

ORDERING INFORMATION

Device Name	Package Options	Case No.	# of Ports			Pressure Type			Device Marking
			None	Single	Dual	Gauge	Differential	Absolute	
Super Small Outline Package (Media Resistant Gel) (MPXHZ6116A Series)									
MPXHZ6116A6U	Rail	1317	•					•	MPXHZ6116A
MPXHZ6116A6T1	Tape & Reel	1317	•					•	MPXHZ6116A

SUPER SMALL OUTLINE PACKAGE

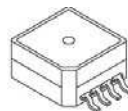

MPXHZ6116A6U/6T1
CASE 1317

Operating Characteristics

Table 1. Operating Characteristics ($V_S = 5.0$ Vdc, $T_A = 25^\circ\text{C}$ unless otherwise noted, Decoupling circuit shown in [Figure 3](#) required to meet electrical specifications.)

Characteristic	Symbol	Min	Typ	Max	Unit
Pressure Range	P_{OP}	20	—	115	kPa
Supply Voltage ⁽¹⁾	V_S	4.75	5.0	5.25	Vdc
Supply Current	I_S	—	6.0	10	mAdc
Full Scale Span ⁽²⁾	V_{FSS}	—	4.2	—	Vdc
Offset ⁽³⁾	V_{off}	0.335	0.399	0.463	Vdc
Sensitivity	V/P	—	44.2	—	mV/kPa
Accuracy ⁽⁴⁾	—	-1.5	—	+1.5	% V_{FSS}
Pressure Range	P_{OP}	20	—	115	kPa

1. Device is ratiometric within this specified excitation range.
2. Full Scale Span (V_{FSS}) is defined as the algebraic difference between the output voltage at full rated pressure and the output voltage at the minimum rated pressure.
3. Offset (V_{off}) is defined as the output voltage at the minimum rated pressure.
4. Accuracy (error budget) is the deviation in actual output from nominal output over the entire pressure range and temperature range as a percent of V_{SS} span at 25°C due to all sources of error including the following:
 - Linearity: Output deviation from a straight line relationship with pressure over the specified pressure range.
 - Temperature Hysteresis: Output deviation at any temperature within the operating temperature range, after the temperature is cycled to and from the minimum or maximum operating temperature points, with zero differential pressure applied.
 - Pressure Hysteresis: Output deviation at any pressure within the specified range, when this pressure is cycled to and from minimum or maximum rated pressure at 25°C .
 - Offset Stability: Output deviation, after 1000 temperature cycles, -40° to 125°C , and 1.5 million pressure cycles, with minimum rated pressure applied.
 - TcSpan: Output deviation over the temperature range of 0° to 85°C , relative to 25°C .
 - TcOffset: Output deviation with minimum pressure applied, over the temperature range of 0° to 85°C , relative to 25°C .

Maximum Ratings

Table 2. Maximum Ratings⁽¹⁾

Rating	Symbol	Value	Units
Maximum Pressure	P_{max}	400	kPa
Storage Temperature	T_{stg}	-40 to +125	°C
Operating Temperature	T_A	-40 to +125	°C
Output Source Current @ Full Scale Output ⁽²⁾	I_{o+}	+0.5	mAdc
Output Sink Current @ Minimum Pressure Offset ⁽²⁾	I_{o-}	-0.5	mAdc

1. Exposure beyond the specified limits may cause permanent damage or degradation to the device.
2. Maximum Output Current is controlled by effective impedance from V_{out} to Gnd or V_{out} to V_S in the application circuit.

Figure 1 shows a block diagram of the internal circuitry integrated on a pressure sensor chip.

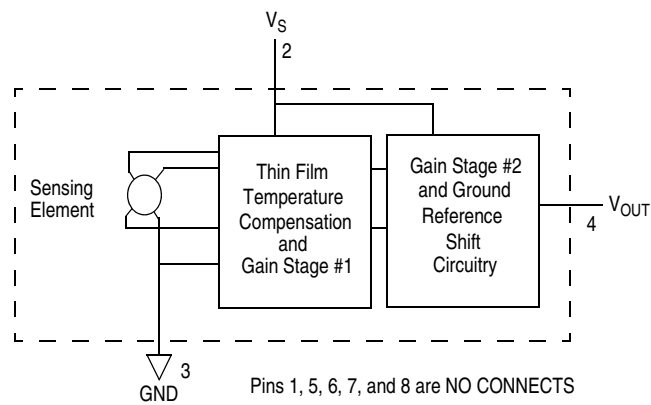

Figure 1. Fully Integrated Pressure Sensor Schematic

On-chip Temperature Compensation and Calibration

The performance over temperature is achieved by integrating the shear–stress strain gauge, temperature compensation, calibration, and signal conditioning circuitry onto a single monolithic chip.

Figure 2 illustrates the configuration in the basic chip carrier (case 1317) prior to porting. A gel die coat isolates the die surface and wire bonds from the environment, while allowing the pressure signal to be transmitted to the sensor diaphragm. The gel die coat and durable thermoplastic package provide a media resistant barrier that allows the sensor to operate reliably in high humidity conditions as well

as common automotive media. NOTE: The MPXHZ6116A series pressure sensor’s operating characteristics, internal reliability and qualification tests are based on use of air as the pressure media. Media, other than air, may have adverse effects on sensor performance and long–term reliability. Contact the factory for information regarding media compatibility in your application.

Figure 3 shows the recommended decoupling circuit for interfacing the integrated sensor to the A/D input of a microprocessor or microcontroller. Proper decoupling of the power supply is recommended.

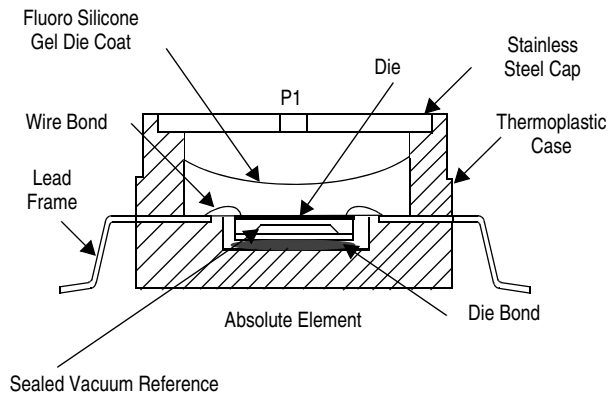

Figure 2. Cross Sectional Diagram SSOP (not to scale)

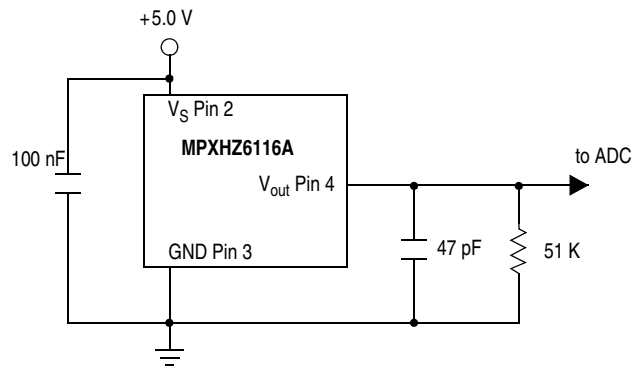

Figure 3. Typical Application Circuit (Output Source Current Operation)

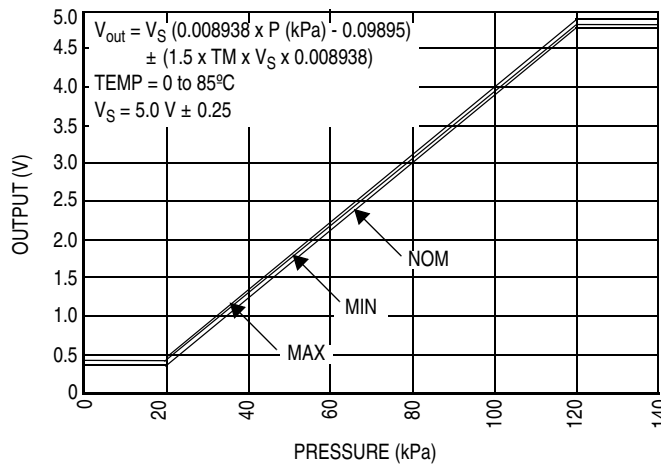
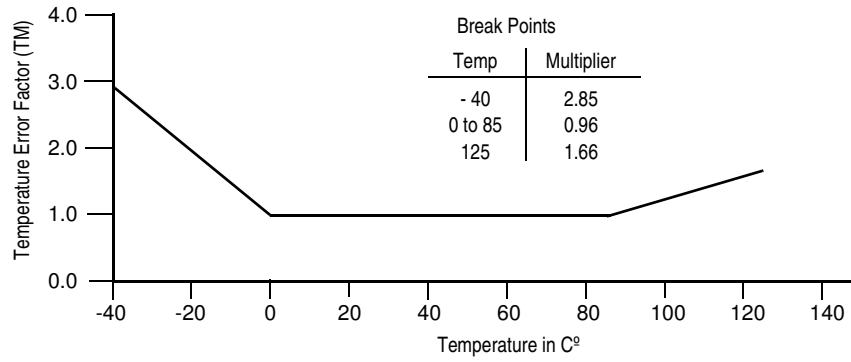

Figure 4. Output vs. Absolute Pressure

Temperature Error Band

MPXHZ6116A SERIES



NOTE: The Temperature Multiplier is a linear response from 0°C to -40°C and from 85°C to 125°C

Pressure Error Band

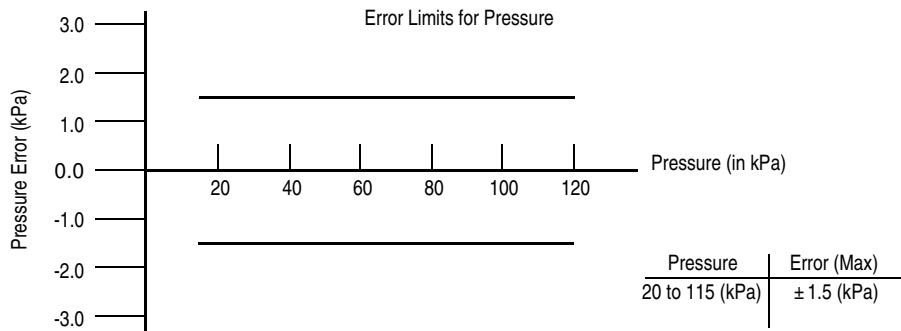

MINIMUM RECOMMENDED FOOTPRINT FOR SUPER SMALL PACKAGES

Surface mount board layout is a critical portion of the total design. The footprint for the semiconductor package must be the correct size to ensure proper solder connection interface between the board and the package. With the correct pad geometry, the packages will self-align when subjected to a

solder reflow process. It is always recommended to fabricate boards with a solder mask layer to avoid bridging and/or shorting between solder pads, especially on tight tolerances and/or tight layouts.

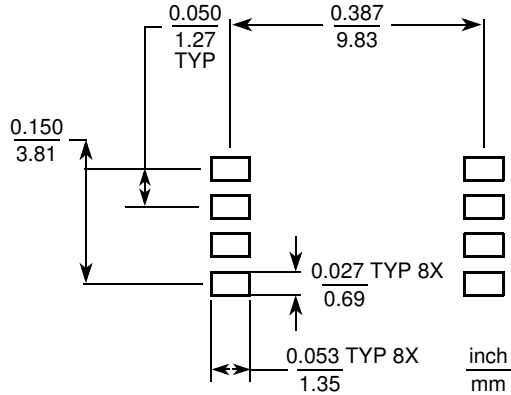
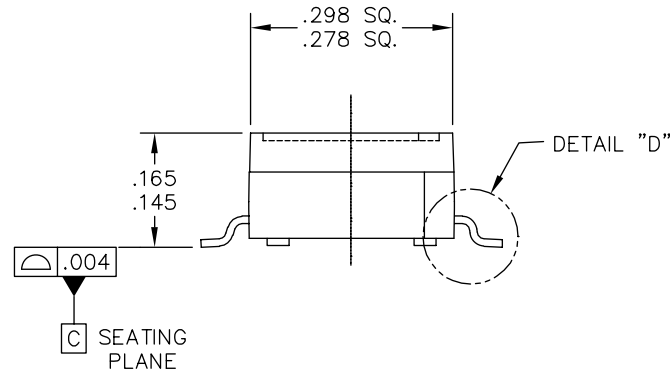
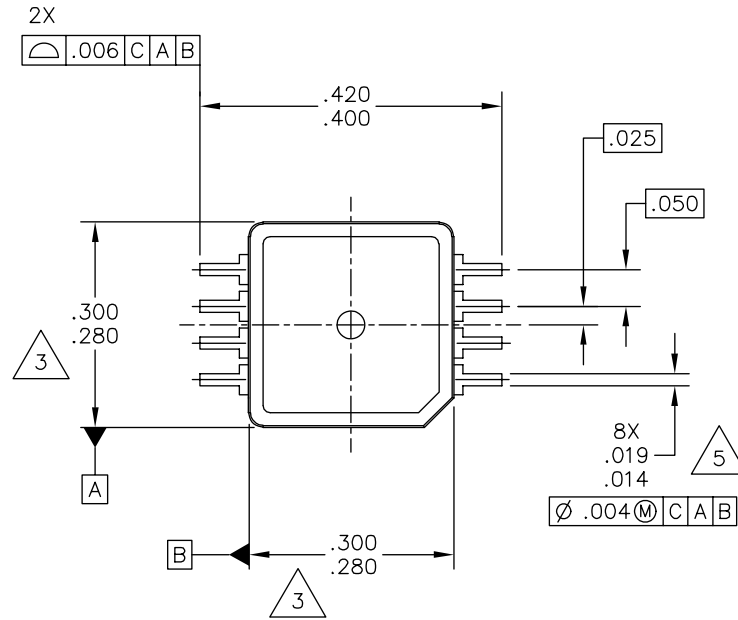

Figure 5. SSOP Footprint (Case 1317)

PACKAGE DIMENSIONS



© FREESCALE SEMICONDUCTOR, INC. ALL RIGHTS RESERVED.		MECHANICAL OUTLINE		PRINT VERSION NOT TO SCALE	
TITLE:	8 LEAD SSOP	DOCUMENT NO: 98ARH99066A		REV: F	
		CASE NUMBER: 1317-04		24 MAY 2005	
		STANDARD: NON-JEDEC			

**CASE 1317-04
 ISSUE F
 SUPER SMALL OUTLINE PACKAGE**

PACKAGE DIMENSIONS

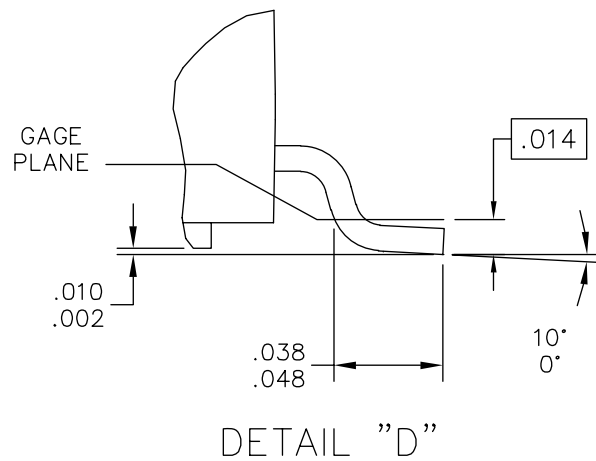

© FREESCALE SEMICONDUCTOR, INC. ALL RIGHTS RESERVED.		MECHANICAL OUTLINE		PRINT VERSION NOT TO SCALE	
TITLE: 8 LEAD SSOP	DOCUMENT NO: 98ARH99066A			REV: F	
	CASE NUMBER: 1317-04			24 MAY 2005	
	STANDARD: NON-JEDEC				

**CASE 1317-04
ISSUE F
SUPER SMALL OUTLINE PACKAGE**

PACKAGE DIMENSIONS

NOTES:

1. ALL DIMENSIONS IN INCHES.
2. DIMENSIONING AND TOLERANCING PER ASME Y14.5M-1994.
3. DIMENSIONS DO NOT INCLUDE MOLD FLASH OR PROTRUSIONS.
MOLD FLASH OR PROTRUSION SHALL NOT EXCEED .006 INCHES PER SIDE.
4. ALL VERTICAL SURFACES TO BE 5° MAXIMUM.
5. DIMENSION DOES NOT INCLUDE DAMBAR PROTRUSION.
ALLOWABLE DAMBAR PROTRUSION SHALL BE .008 INCHES MAXIMUM.

© FREESCALE SEMICONDUCTOR, INC. ALL RIGHTS RESERVED.	MECHANICAL OUTLINE	PRINT VERSION NOT TO SCALE	
TITLE: 8 LEAD SSOP	DOCUMENT NO: 98ARH99066A	REV: F	
	CASE NUMBER: 1317-04	24 MAY 2005	
	STANDARD: NON-JEDEC		

**CASE 1317-04
ISSUE F
SUPER SMALL OUTLINE PACKAGE**

How to Reach Us:

Home Page:

www.freescale.com

Web Support:

<http://www.freescale.com/support>

USA/Europe or Locations Not Listed:

Freescale Semiconductor, Inc.
Technical Information Center, EL516
2100 East Elliot Road
Tempe, Arizona 85284
1-800-521-6274 or +1-480-768-2130
www.freescale.com/support

Europe, Middle East, and Africa:

Freescale Halbleiter Deutschland GmbH
Technical Information Center
Schatzbogen 7
81829 Muenchen, Germany
+44 1296 380 456 (English)
+46 8 52200080 (English)
+49 89 92103 559 (German)
+33 1 69 35 48 48 (French)
www.freescale.com/support

Japan:

Freescale Semiconductor Japan Ltd.
Headquarters
ARCO Tower 15F
1-8-1, Shimo-Meguro, Meguro-ku,
Tokyo 153-0064
Japan
0120 191014 or +81 3 5437 9125
support.japan@freescale.com

Asia/Pacific:

Freescale Semiconductor China Ltd.
Exchange Building 23F
No. 118 Jianguo Road
Chaoyang District
Beijing 100022
China
+86 010 5879 8000
support.asia@freescale.com

For Literature Requests Only:

Freescale Semiconductor Literature Distribution Center
1-800-441-2447 or +1-303-675-2140
Fax: +1-303-675-2150
LDCForFreescaleSemiconductor@hibbertgroup.com

Information in this document is provided solely to enable system and software implementers to use Freescale Semiconductor products. There are no express or implied copyright licenses granted hereunder to design or fabricate any integrated circuits or integrated circuits based on the information in this document.

Freescale Semiconductor reserves the right to make changes without further notice to any products herein. Freescale Semiconductor makes no warranty, representation or guarantee regarding the suitability of its products for any particular purpose, nor does Freescale Semiconductor assume any liability arising out of the application or use of any product or circuit, and specifically disclaims any and all liability, including without limitation consequential or incidental damages. "Typical" parameters that may be provided in Freescale Semiconductor data sheets and/or specifications can and do vary in different applications and actual performance may vary over time. All operating parameters, including "Typicals", must be validated for each customer application by customer's technical experts. Freescale Semiconductor does not convey any license under its patent rights nor the rights of others. Freescale Semiconductor products are not designed, intended, or authorized for use as components in systems intended for surgical implant into the body, or other applications intended to support or sustain life, or for any other application in which the failure of the Freescale Semiconductor product could create a situation where personal injury or death may occur. Should Buyer purchase or use Freescale Semiconductor products for any such unintended or unauthorized application, Buyer shall indemnify and hold Freescale Semiconductor and its officers, employees, subsidiaries, affiliates, and distributors harmless against all claims, costs, damages, and expenses, and reasonable attorney fees arising out of, directly or indirectly, any claim of personal injury or death associated with such unintended or unauthorized use, even if such claim alleges that Freescale Semiconductor was negligent regarding the design or manufacture of the part.

Freescale and the Freescale logo are trademarks of Freescale Semiconductor, Inc., Reg. U.S. Pat. & Tm. Off. All other product or service names are the property of their respective owners.

© Freescale Semiconductor, Inc. 2010. All rights reserved.

