



Features

- Single Supply Voltage 3.0V to 5.0V
- No external matching components
- 28dB Typical Gain Across Band
- P_{OUT} = 17 dBm @ <4% TYP EVM across Operating Band
- 4900MHz to 5850MHz Frequency Range

Applications

- IEEE802.11a/n and IEEE802.16e Applications
- HyperLAN
- WiFi Systems
- Commercial and Consumer Systems
- Portable Battery-Powered Equipment
- Spread-Spectrum and MMDS Systems

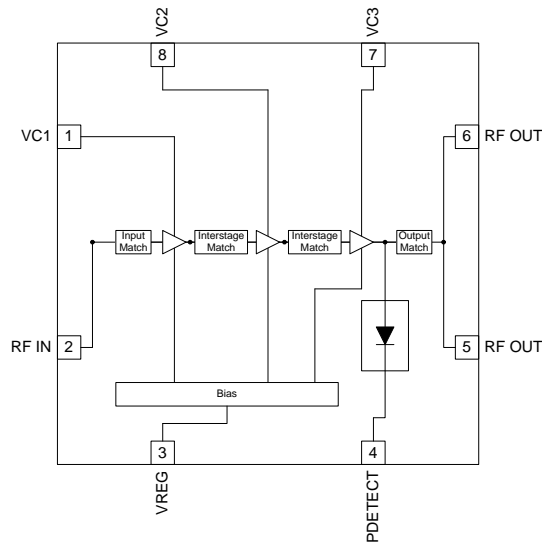

Functional Block Diagram

Product Description

The RF5355 is a linear, medium-power, high-efficiency power amplifier IC designed specifically for battery-powered WiFi applications such as PC cards, mini PCI, and compact flash applications. It is also designed to meet IEEE802.11a, IEEE802.11n, IEEE802.16e (4.9GHz to 5.850GHz only) WiMax, FCC, and ETSI requirements for operation in the 4.9GHz to 5.850GHz band. The device is manufactured on an advanced InGaP GaAs Heterojunction Bipolar Transistor process, and has been designed for use as the final RF amplifier in 5GHz WiFi and other spread-spectrum transmitters. The device is provided in a QFN, 8-pin, 2.2mmx2.2mmx0.45mm, leadless chip carrier with backside ground. The RF5355 operates from a single supply and will be easily incorporated into WiFi and other designs with minimal external components.

Ordering Information

RF5355	Standard 25 piece bag
RF5355SR	Standard 100 piece reel
RF5355TR7	Standard 2500 piece reel
RF5355PCK-410	Fully Assembled Evaluation Board and 5 loose sample pieces.

Optimum Technology Matching® Applied

- | | | | |
|---|--------------------------------------|-------------------------------------|-----------------------------------|
| <input type="checkbox"/> GaAs HBT | <input type="checkbox"/> SiGe BiCMOS | <input type="checkbox"/> GaAs pHEMT | <input type="checkbox"/> GaN HEMT |
| <input type="checkbox"/> GaAs MESFET | <input type="checkbox"/> Si BiCMOS | <input type="checkbox"/> Si CMOS | <input type="checkbox"/> RF MEMS |
| <input checked="" type="checkbox"/> InGaP HBT | <input type="checkbox"/> SiGe HBT | <input type="checkbox"/> Si BJT | <input type="checkbox"/> LDMOS |

RF MICRO DEVICES®, RFMD®, Optimum Technology Matching®, Enabling Wireless Connectivity™, PowerStar®, POLARIS™ TOTAL RADIO™ and UltimateBlue™ are trademarks of RFMD, LLC. BLUETOOTH is a trademark owned by Bluetooth SIG, Inc., U.S.A. and licensed for use by RFMD. All other trade names, trademarks and registered trademarks are the property of their respective owners. ©2006, RF Micro Devices, Inc.

Absolute Maximum Ratings

Parameter	Rating	Unit
Supply Voltage (No RF Applied)	-0.5 to +6.0	V _{DC}
Supply voltage (RF Applied)	-0.5 to 5.25	V _{DC}
Power Control Voltage (V _{REG})	-0.5 to 3.5	V
DC Supply Current	400	mA
Input RF Power	+10	dBm
Operating Ambient Temperature	-30 to +85	°C
Storage Temperature	-40 to +150	°C
Moisture sensitivity	JEDEC Level 3	



Caution! ESD sensitive device.

Exceeding any one or a combination of the Absolute Maximum Rating conditions may cause permanent damage to the device. Extended application of Absolute Maximum Rating conditions to the device may reduce device reliability. Specified typical performance or functional operation of the device under Absolute Maximum Rating conditions is not implied.

RoHS status based on EUDirective2002/95/EC (at time of this document revision).

The information in this publication is believed to be accurate and reliable. However, no responsibility is assumed by RF Micro Devices, Inc. ("RFMD") for its use, nor for any infringement of patents, or other rights of third parties, resulting from its use. No license is granted by implication or otherwise under any patent or patent rights of RFMD. RFMD reserves the right to change component circuitry, recommended application circuitry and specifications at any time without prior notice.

Parameter	Specification			Unit	Condition
	Min.	Typ.	Max.		
Compliance					T = +25 °C; V _{CC} = 3.3V; V _{REG} = 2.85V; pulsed at 1% to 100% duty cycle; Freq = 4.9GHz to 5.85GHz; unless otherwise noted. IEEE802.11a; IEEE802.11n; IEEE802.16e (4.9GHz to 5.85GHz)
Frequency Range	4.90		5.85	GHz	Lower, middle and upper U-NII
Output Power	16	17		dBm	-30 to +85C, over V _{CC} range, over frequency, and nominal V _{REG}
EVM*		3	4	%	RMS, mean @ P _{OUT} = 17 dBm at nominal conditions. Measured with a standard IEEE802.11a waveform, 54Mbps, 64QAM.
Gain					At P _{OUT} = 17 dBm
	25	28	33	dB	4.9GHz to 5.1GHz
	25	28	33	dB	5.15GHz to 5.35GHz
	25	28	32	dB	5.70GHz to 5.85GHz
Gain Variance			1.5	±dB	4.9GHz to 5.850GHz, -30 °C to +85 °C (in any 200MHz frequency)
OP1dB		25		dBm	V _{CC} = 3.3V, V _{REG} = 2.85V, and using CW waveform at 5.85GHz
Power Detector					
P _{OUT} @8dBm	0.7	0.8	0.9	V	At nominal conditions, over operating temperature
P _{OUT} @17dBm	1.4	1.6	1.7	V	At nominal conditions, over operating temperature
Power Added Efficiency	6.6	10.8	13.7	%	At P _{OUT} = +17 dBm, over temperature -30 °C to +85 °C, over V _{CC} range, and over frequency at nominal V _{REG}
Power Supply	3.0	3.3	4.0	V	
V _{REG} Voltage	2.75	2.85	2.95	V	Recommended Operating V _{REG} range
			3.3	V	V _{REG} should not exceed this level
Current					
Operating	120	140	170	mA	At RF P _{OUT} = +17 dBm with IEEE802.11a waveform and 54Mbps data rate over operating temperature range
Quiescent		95	110	mA	At nominal conditions, over operating temperature range
I _{REG}		10		mA	
Shutdown			5	µA	
Output VSWR			4:1		Stable and no spurs above -47 dBm
			10:1		No damage

*The EVM specification includes a source EVM level of 0.5% to 0.7%.

Parameter	Specification			Unit	Condition
	Min.	Typ.	Max.		
IEEE802.11a Spectral Mask per FCC Part 15.205	-43			dBm	Amplifier set up for best IEEE802.11a performance; $F_C=5180\text{MHz}$; $RF P_{OUT}=+17\text{ dBm}$; $T=+25^\circ\text{C}$, Measured @ 5150MHz
	-43			dBm	Amplifier set up for best IEEE802.11a performance; $F_C=5320\text{MHz}$; $RF P_{OUT}=+17\text{ dBm}$; $T=+25^\circ\text{C}$, Measured @ 5350MHz
Second Harmonic	-14			dBm	At nominal conditions, at $P_{OUT}=+17\text{ dBm}$, measured in 1MHz RBW with 6Mbps 11a signal, Fundamental Frequency is between 4.9GHz to 5.299GHz.
	-23			dBm	At nominal conditions, at $P_{OUT}=+17\text{ dBm}$, measured in 1MHz RBW with 6Mbps 11a signal, Fundamental Frequency is between 5.3GHz to 5.85GHz.
Input Return Loss		-10		dB	
Turn-on Time		0.5	1.5	μS	Output stable to within 90% of final gain

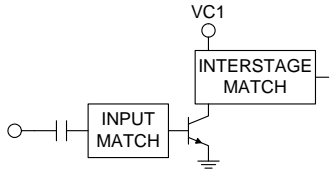
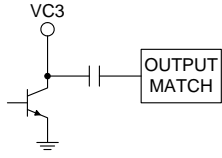
Pin	Function	Description	Interface Schematic
1	VC1	First stage supply voltage.	
2	RF IN	RF input. Input is matched to 50Ω and DC block is provided internally.	
3	VREG	First, second and third stage bias voltage combined on the die to one external voltage. This pin requires regulated supply for best performance.	
4	PDETECT	Power detector voltage is proportional to RF output power. May need external decoupling capacitor for module stability. May need external circuitry to bring output voltage to desired level.	
5	RF OUT	RF output is internally matched to 50Ω and DC-blocking capacitor of about 1.8pF to 5.6pF depending on the layout is required externally if a switch is used immediately after the PA that has DC voltage at the switch input which is the same node at the RF output of the PA.	
6	RF OUT	Same as pin 5.	See pin 5.
7	VC3	Supply voltage for the third stage.	
8	VC2	Supply voltage for the second stage.	
Pkg Base	GND	Ground connection. The backside of the package should be connected to the ground plane through a short path (i.e., vias under the device will be required).	

Package Drawing
QFN, 8-Pin, 2.2x2.2x0.45mm

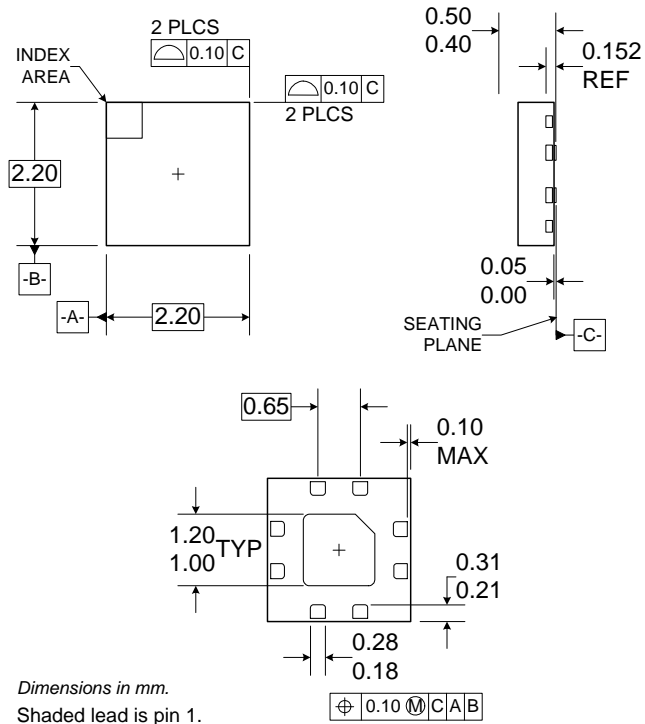

PCB Design Requirements

PCB Surface Finish

The PCB surface finish used for RFMD's qualification process is electroless nickel, immersion gold. Typical thickness is 3 micro-inch to 8 micro-inch gold over 180 micro-inch nickel.

PCB Land Pattern Recommendation *

PCB land patterns for RFMD components are based on IPC-7351 standards and RFMD empirical data. The pad pattern shown has been developed and tested for optimized assembly at RFMD. The PCB land pattern has been developed to accommodate lead and package tolerances. Since surface mount processes vary from company to company, careful process development is recommended.

PCB Metal Land Pattern

A = 0.280 x 0.310 (mm) Typ
 B = 0.310 x 0.280 (mm) Typ
 C = 1.100 (mm) Sq

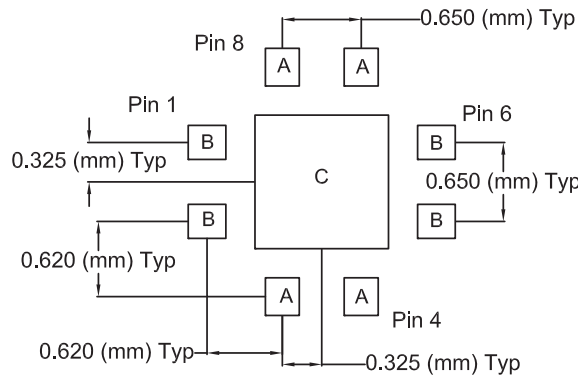

PCB Solder Mask Pattern

A = 0.42 x 0.45 (mm) Typ
 B = 0.45 x 0.42 (mm) Typ
 C = 1.24 (mm) Sq

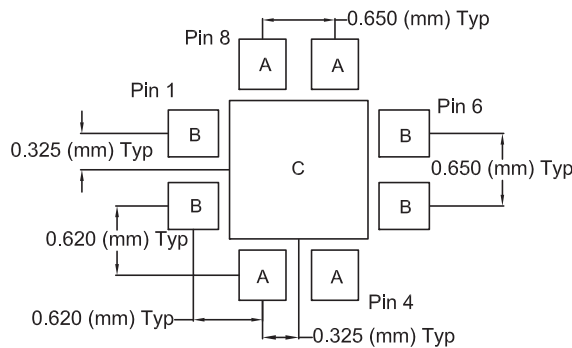

PCB Stencil Pattern

A = 0.25 x 0.28 (mm) Typ
 B = 0.28 x 0.25 (mm) Typ
 C = 0.99 (mm) Sq

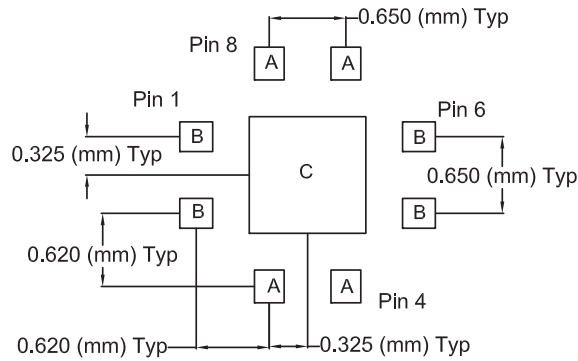

Note: Thermal vias for center slug “C” should be incorporated into the PCB design. The number and size of thermal vias will depend on the application. Example of the number and size of vias can be found on the RFMD evaluation board layout.

Theory of Operation

The RF5355 is a three-stage device with a minimum gain of 28dB in the 4.9GHz to 5.850GHz ISM band. The RF5355 is designed primarily for IEEE802.11a, IEEE802.11n, and IEEE802.16e in the 4.9GHz to 5.850GHz band where the available supply voltage and current are limited. This amplifier will operate to (and below) the lowest expected voltage made available by a typical PCMCIA slot in a laptop PC, and will maintain required linearity at decreased supply voltages.

The RF5355 requires only a single positive supply of 3.3V nominal (or greater) to operate to full specifications. Power control is provided through one bias pin, V_{REG} . The three bias voltages for the three stages are connected together on the die and only one bias control voltage is needed (V_{REG}). There is no external matching required on the input and output of the part, thus allowing a minimal bill of material (BOM) parts count in end applications. Both the input and the output of the device are DC-blocked.

For best results, the PA circuit layout from the evaluation board should be copied as closely as possible, particularly the ground layout and ground vias. Other configurations may also work, but the design process is much easier and quicker if the layout is copied from the RF5355 evaluation board. Gerber files of our designs are available on request. The RF5355 is not a difficult part to implement, but care in circuit layout and component selection is always advisable when designing circuits to operate at 5GHz.

The RF5355 has primarily been characterized with a voltage on V_{REG} of $2.85V_{DC}$. However, the RF5355 will operate from a wide range of control voltages. If you prefer to use a control voltage that is significantly different than $2.85V_{DC}$, contact RFMD Sales or Applications Engineering for additional data and guidance.

Evaluation Board Schematic
RF5355PCBA Evaluation Board (4.9GHz to 5.85GHz)

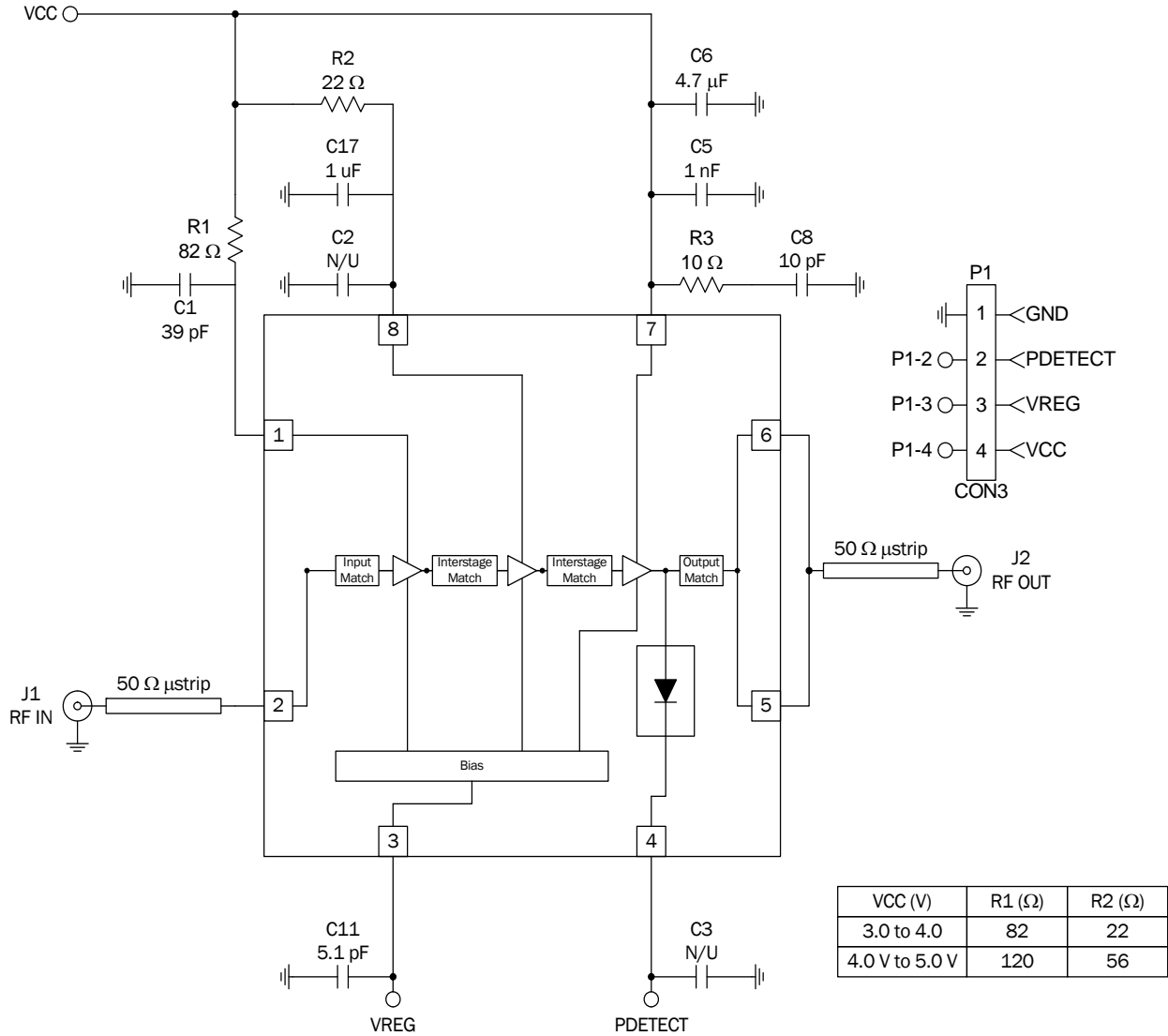

The following components C11, R3, and C8 may be left unpopulated without degradation in performance depending on the layout.

Evaluation Board Layout Board Size 1.2" x 1.2" Board Thickness 0.032", Board Material FR-4, Multi-Layer

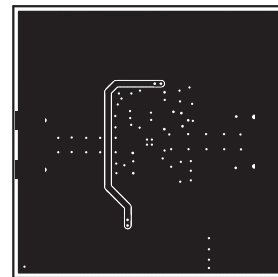
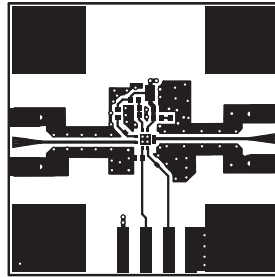
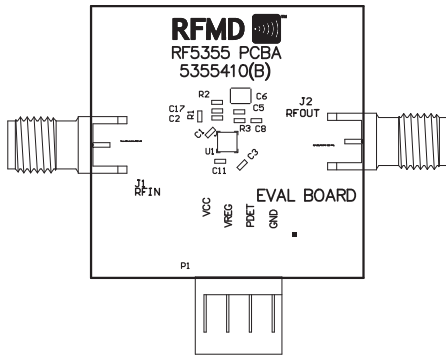

EVM versus Output Power

$V_{CC}=3.3V$; $V_{REG}=2.85V$; Temp= $25^{\circ}C$

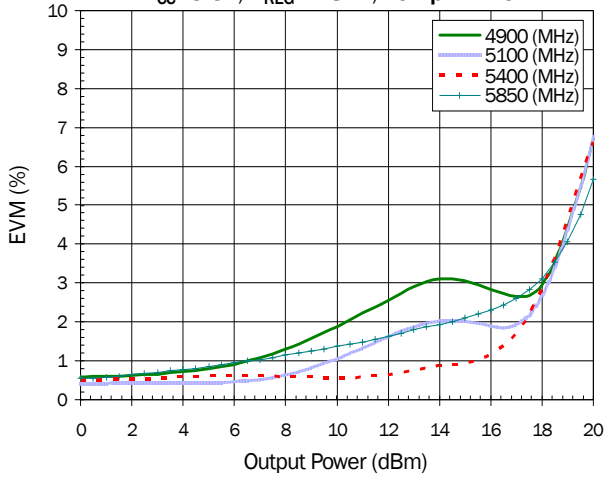

Gain versus Output Power

$V_{CC}=3.3V$; $V_{REG}=2.85V$; Temp= $25^{\circ}C$

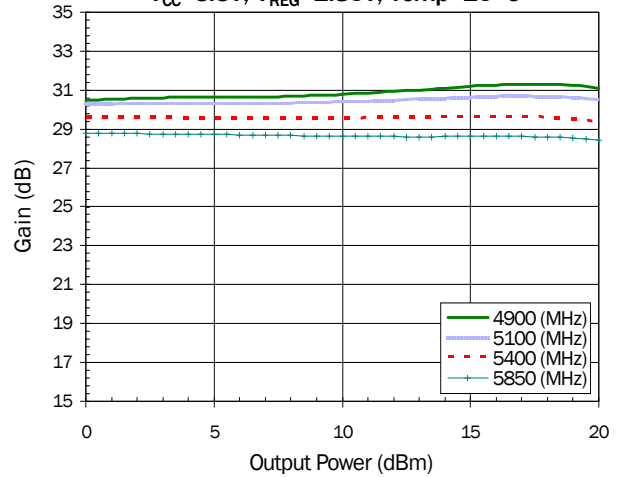

I_{CC} versus Output Power

$V_{CC}=3.3V$; $V_{REG}=2.85V$; Temp= $25^{\circ}C$

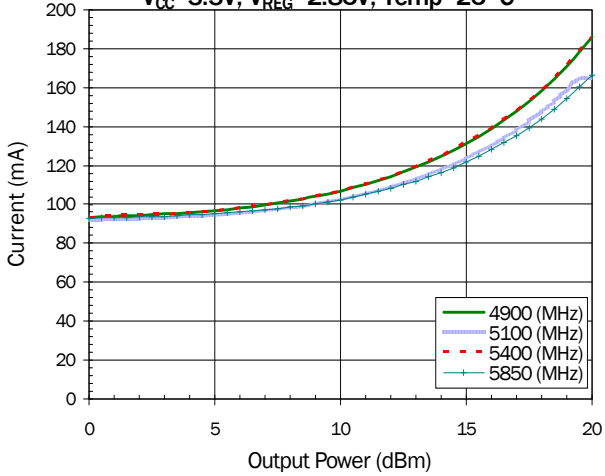

Power Detector versus Output Power

$V_{CC}=3.3V$; $V_{REG}=2.85V$; Temp= $25^{\circ}C$

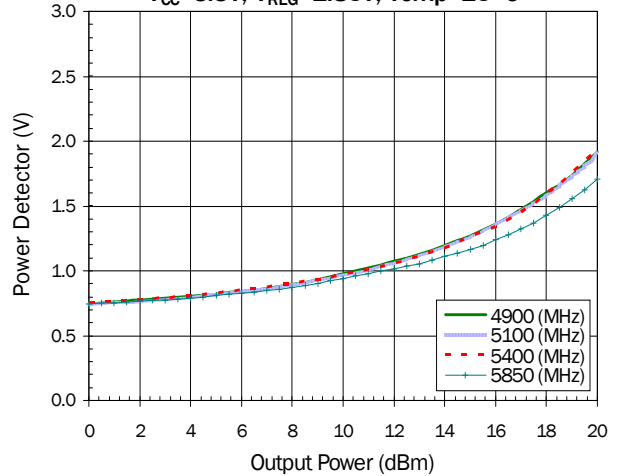

I_{REG} versus Output Power

$V_{CC}=3.3V$; $V_{REG}=2.85V$; Temp= $25^{\circ}C$

