



Product Description

The R2005200P12 is a hybrid reverse amplifier. The part employs a GaAs die. It has extremely low distortion and superior return loss performance. The part also provides optimal reliability with low noise and is well suited for 5 MHz to 200MHz CATV amplifiers for reverse channel systems.

Features

- Excellent Linearity
- Superior Return Loss Performance
- Extremely Low Distortion
- Optimal Reliability
- Low Noise
- Unconditionally Stable Under All Terminations
- 20.0dB Typ. Gain at 200MHz
- 360mA Max. at 12VDC

Applications

- 5 MHz to 200MHz CATV Amplifier For Reverse Channel Systems

Optimum Technology Matching® Applied

- GaAs HBT
- GaAs MESFET
- InGaP HBT
- SiGe BiCMOS
- Si BiCMOS
- SiGe HBT
- GaAs pHEMT
- Si CMOS
- Si BJT
- GaN HEMT
- RF MEMS

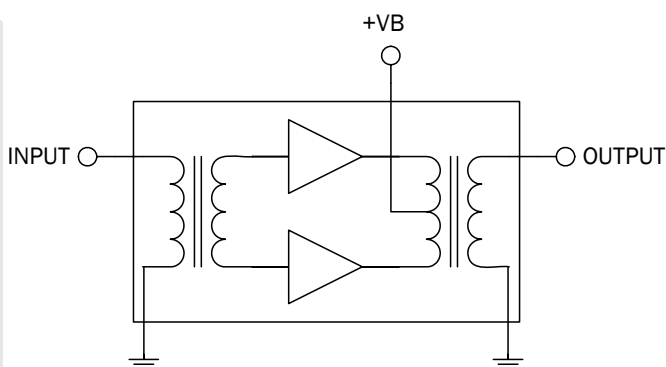

Parameter	Specification			Unit	Condition
	Min.	Typ.	Max.		
Overall					$V_B = 12V; T_{MB} = 30^\circ C; Z_S = Z_L = 75\Omega$
Power Gain	19.5	20.0	20.5	dB	f=5MHz
	19.5	20.0	21.0	dB	f=200MHz
Slope ^[1]	-0.5	0.0	0.5	dB	f=5MHz to 200MHz
Flatness of Frequency Response			±0.5	dB	f=5MHz to 200MHz
Input Return Loss	20.0			dB	f=5MHz to 65MHz
	18.0			dB	f=65MHz to 200MHz
Output Return Loss	20.0			dB	f=5MHz to 65MHz
	18.0			dB	f=65MHz to 200MHz
Noise Figure		4.4	5.0	dB	f=10MHz
		2.2	2.5	dB	f=200MHz
Total Current Consumption (DC)	350.0	355.0	360.0	mA	

1. The slope is defined as the difference between the gain at the start frequency and the gain at the stop frequency.

Absolute Maximum Ratings

Parameter	Rating	Unit
RF Input Voltage (single tone)	70	dBmV
DC Supply Over-Voltage (5 minutes)	15	V
Storage Temperature	-40 to +100	°C
Operating Mounting Base Temperature	-30 to +100	°C



Caution! ESD sensitive device.

Exceeding any one or a combination of the Absolute Maximum Rating conditions may cause permanent damage to the device. Extended application of Absolute Maximum Rating conditions to the device may reduce device reliability. Specified typical performance or functional operation of the device under Absolute Maximum Rating conditions is not implied.

RoHS status based on EU Directive 2002/95/EC (at time of this document revision).

The information in this publication is believed to be accurate and reliable. However, no responsibility is assumed by RF Micro Devices, Inc. ("RFMD") for its use, nor for any infringement of patents, or other rights of third parties, resulting from its use. No license is granted by implication or otherwise under any patent or patent rights of RFMD. RFMD reserves the right to change component circuitry, recommended application circuitry and specifications at any time without prior notice.

Parameter	Specification			Unit	Condition
	Min.	Typ.	Max.		
Distortion data 5MHz to 200MHz					
CTB			-73	dBc	26 ch flat; $V_0 = 50 \text{ dBmV}^{[2]}$
XMOD			-68	dB	26 ch flat; $V_0 = 50 \text{ dBmV}^{[2]}$
CSO			-70	dBc	26 ch flat; $V_0 = 50 \text{ dBmV}^{[2]}$
d_2			-75	dBc	[3]
V_0	65			dBmV	$D_{IM} = -60 \text{ dB}^{[4]}$

2. 26 channels, NTSC frequency raster: T7-T13 (7.0MHz to 43.0MHz), 2-6 (55.25MHz - 83.25MHz), A-11 (121.25MHz - 199.25MHz), +50dBmV flat output level.

3. $f_1 = 83.25 \text{ MHz}$; $V_1 = 50 \text{ dBmV}$; $f_2 = 109.25 \text{ MHz}$; $V_2 = 50 \text{ dBmV}$; $f_{\text{TEST}} = f_1 + f_2 = 192.5 \text{ MHz}$.

4. $f_1 = 187.25 \text{ MHz}$; $V_1 = V_0$; $f_2 = 194.25 \text{ MHz}$; $V_2 = V_1 - 6 \text{ dB}$; $f_3 = 196.25 \text{ MHz}$; $V_3 = V_1 - 6 \text{ dB}$; $f_{\text{TEST}} = f_1 + f_2 - f_3 = 185.25 \text{ MHz}$. according to DIN45004B.

Composite Second Order (CSO) - The CSO parameter (both sum and difference products) is defined by the NCTA.

Composite Triple Beat (CTB) - The CTB parameter is defined by the NCTA.

Cross Modulation (XMOD) - Cross modulation (XMOD) is measured at baseband (selective voltmeter method), referenced to 100% modulation of the carrier being tested.

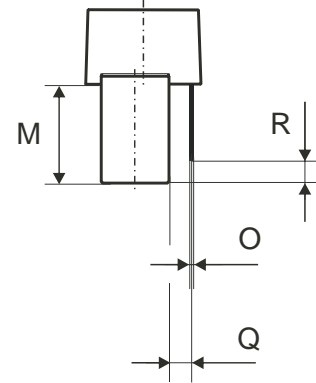
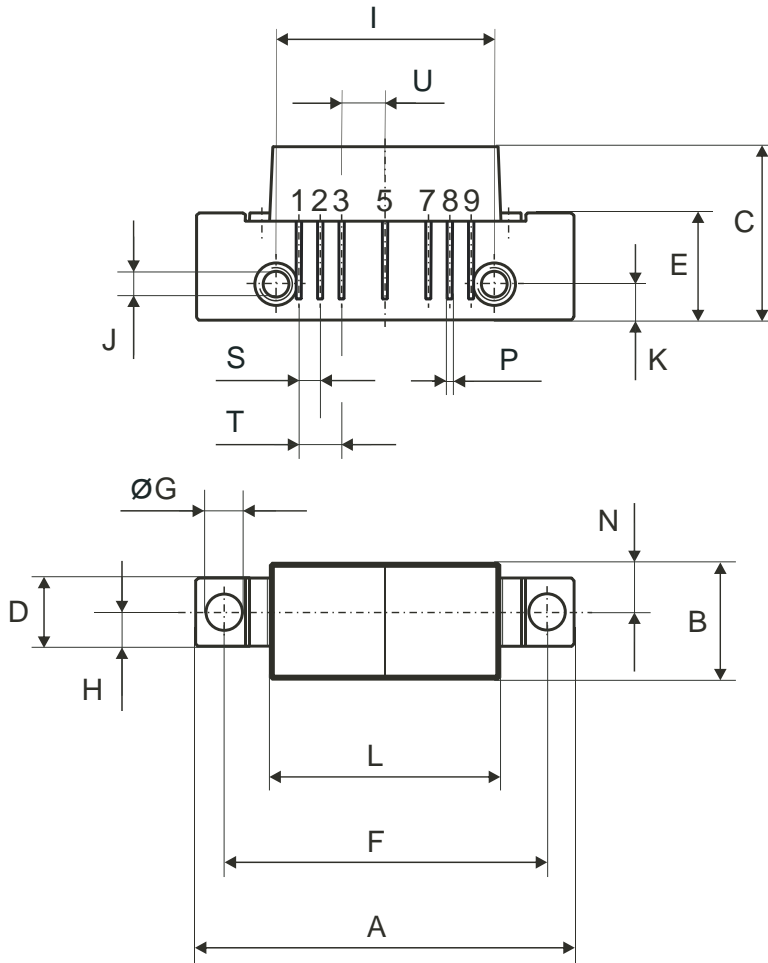

All Dimensions in mm:

	nominal	min	max
A	44,6 ± 0,2	44,4	44,8
B	13,6 ± 0,2	13,4	13,8
C	20,4 ± 0,5	19,9	20,9
D	8 ± 0,15	7,85	8,15
E	12,6 ± 0,15	12,45	12,75
F	38,1 ± 0,2	37,9	38,3
G	4 ^{+0,2 / -0,05}	3,95	4,2
H	4 ± 0,2	3,8	4,2
I	25,4 ± 0,2	25,2	25,6
J	UNC 6-32	-	-
K	4,2 ± 0,2	4,0	4,4
L	27,2 ± 0,2	27,0	27,4
M	11,6 ± 0,5	11,1	12,1
N	5,8 ± 0,4	5,4	6,2
O	0,25 ± 0,02	0,23	0,27
P	0,45 ± 0,03	0,42	0,48
Q	2,54 ± 0,3	2,24	2,84
R	2,54 ± 0,5	2,04	3,04
S	2,54 ± 0,25	2,29	2,79
T	5,08 ± 0,25	4,83	5,33
U	5,08 ± 0,25	4,83	5,33

Pinning:

	1	2	3	4	5	6	7	8	9
	INPUT	GND	GND	+VB			GND	GND	OUTPUT

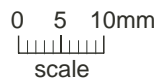

Notes:

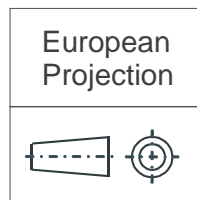

R2005200P12



rfmd.com