



Product Description

The R3005300L is a hybrid reverse amplifier. The part employs a silicon die. It has extremely low distortion and superior return loss performance. The part also provides optimal reliability with low noise and is well suited for 5 MHz to 300 MHz CATV amplifiers for reverse channel systems.

Features

- Excellent Linearity
- Superior Return Loss Performance
- Extremely Low Distortion
- Optimal Reliability
- Low Noise
- Unconditionally Stable Under All Terminations
- 30.0dB Typ. Gain at 300MHz
- 160mA Max. at 24VDC

Applications

- 5 MHz to 300 MHz CATV Amplifier For Reverse Channel Systems

Optimum Technology Matching® Applied

- GaAs HBT
- GaAs MESFET
- InGaP HBT
- SiGe BiCMOS
- Si BiCMOS
- SiGe HBT
- GaAs pHEMT
- Si CMOS
- Si BJT
- GaN HEMT
- RF MEMS

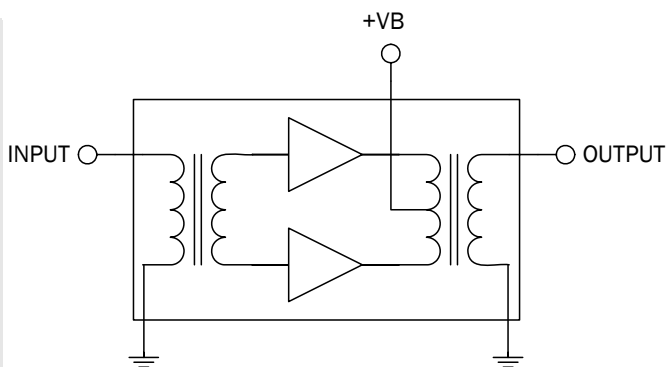

Parameter	Specification			Unit	Condition
	Min.	Typ.	Max.		
Overall					$V_B = 24V; T_{MB} = 30^\circ C; Z_S = Z_L = 75\Omega$
Power Gain	29.4	30.0	30.6	dB	f=5MHz
	29.1	30.0	31.1	dB	f=300MHz
Slope [1]	-0.3	0.0	0.5	dB	f=5MHz to 300MHz
Flatness of Frequency Response	-0.3		0.3	dB	f=5MHz to 300MHz
Input Return Loss	20.0			dB	f=5MHz to 200MHz
	16.0			dB	f=200MHz to 300MHz
Output Return Loss	20.0			dB	f=5MHz to 200MHz
	16.0			dB	f=200MHz to 300MHz
Reverse Isolation			-40.0	dB	f=5MHz to 300MHz
Noise Figure			6.3	dB	f=5MHz to 300MHz
Total Current Consumption (DC)		145.0	160.0	mA	

1. The slope is defined as the difference between the gain at the start frequency and the gain at the stop frequency.

Absolute Maximum Ratings

Parameter	Rating	Unit
RF Input Voltage (single tone)	50	dBmV
DC Supply Over-Voltage (5 minutes)	30	V
Storage Temperature	-40 to +100	°C
Operating Mounting Base Temperature	-30 to +100	°C



Caution! ESD sensitive device.

Exceeding any one or a combination of the Absolute Maximum Rating conditions may cause permanent damage to the device. Extended application of Absolute Maximum Rating conditions to the device may reduce device reliability. Specified typical performance or functional operation of the device under Absolute Maximum Rating conditions is not implied.

RoHS status based on EU Directive 2002/95/EC (at time of this document revision).

The information in this publication is believed to be accurate and reliable. However, no responsibility is assumed by RF Micro Devices, Inc. ("RFMD") for its use, nor for any infringement of patents, or other rights of third parties, resulting from its use. No license is granted by implication or otherwise under any patent or patent rights of RFMD. RFMD reserves the right to change component circuitry, recommended application circuitry and specifications at any time without prior notice.

Parameter	Specification			Unit	Condition
	Min.	Typ.	Max.		
Distortion data 5MHz to 300MHz					
CTB			-74	dBc	7 ch flat; $V_0 = 50 \text{ dBmV}^{[2]}$
			-60	dBc	22 ch flat; $V_0 = 50 \text{ dBmV}^{[3]}$
XMOD			-66	dBc	7 ch flat; $V_0 = 50 \text{ dBmV}^{[2]}$
			-53	dBc	22 ch flat; $V_0 = 50 \text{ dBmV}^{[3]}$
CSO			-72	dBc	7 ch flat; $V_0 = 50 \text{ dBmV}^{[2]}$
			-68	dBc	22 ch flat; $V_0 = 50 \text{ dBmV}^{[3]}$
d_2			-70	dBc	^[4]
V_0	62.0			dBmV	$D_{IM} = -60 \text{ dB}^{[5]}$

2. 7 channels, NTSC frequency raster: T7-T13(7.0MHz to 43.0MHz) +50 dBmV flat output level.

3. 22 channels, NTSC frequency raster: T7-T13 plus 2-6 (55.25MHz to 83.25MHz) and A-7 (121.25 - 175.25), +50 dBmV flat output level.

3. $f_1 = 83.25 \text{ MHz}$; $V_1 = 50 \text{ dBmV}$; $f_2 = 109.25 \text{ MHz}$; $V_2 = 50 \text{ dBmV}$; $f_{\text{TEST}} = f_1 + f_2 = 192.5 \text{ MHz}$.

4. $f_1 = 187.25 \text{ MHz}$; $V_1 = 50 \text{ dBmV}$; $f_2 = 194.25 \text{ MHz}$; $V_2 = V_1 - 6 \text{ dB}$; $f_3 = 196.25 \text{ MHz}$; $V_3 = V_1 - 6 \text{ dB}$; $f_{\text{TEST}} = f_1 + f_2 - f_3 = 185.25 \text{ MHz}$, according to DIN45004B.

Composite Second Order (CSO) - The CSO parameter (both sum and difference products) is defined by the NCTA.

Composite Triple Beat (CTB) - The CTB parameter is defined by the NCTA.

Cross Modulation (XMOD) - Cross modulation (XMOD) is measured at baseband (selective voltmeter method), referenced to 100% modulation of the carrier being tested.

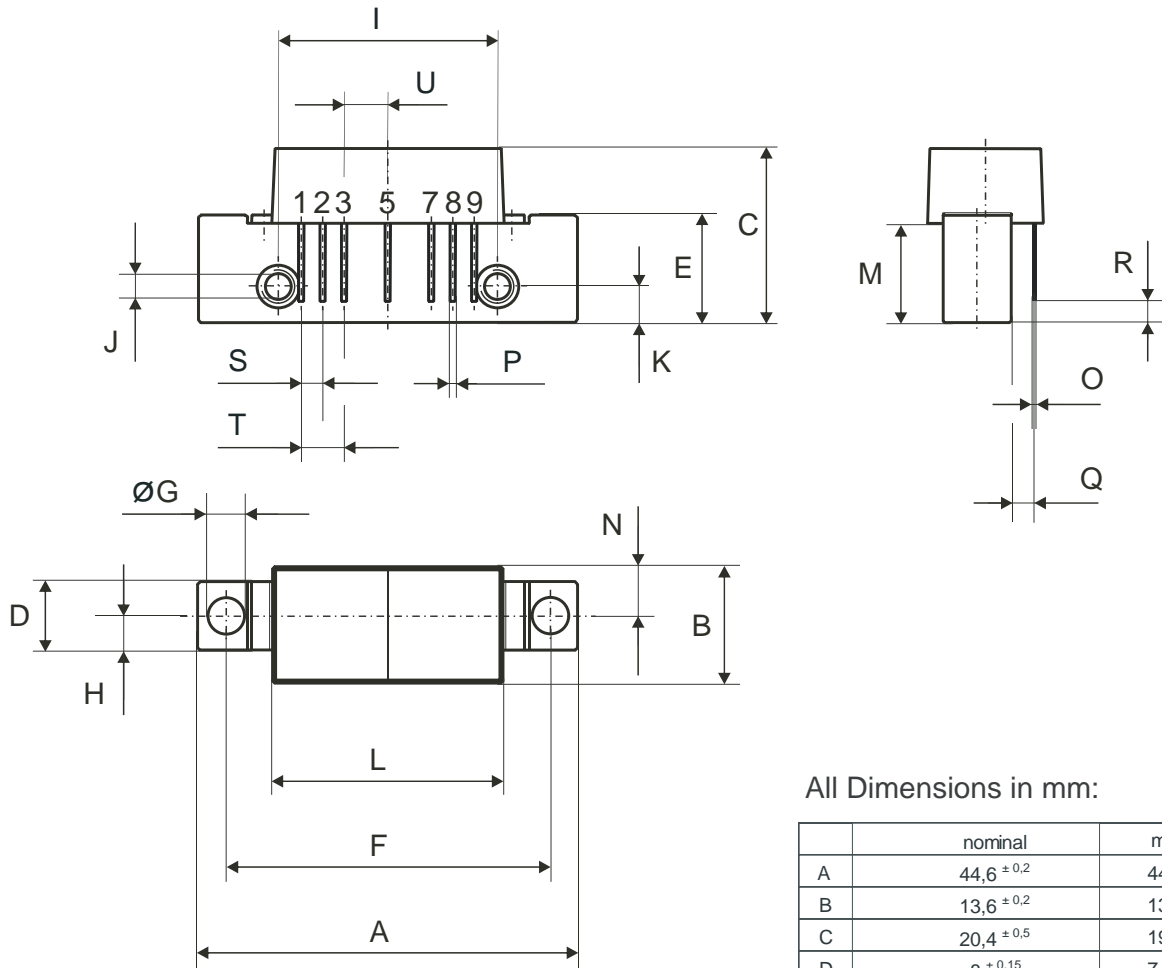

All Dimensions in mm:

	nominal	min	max
A	44,6 ± 0,2	44,4	44,8
B	13,6 ± 0,2	13,4	13,8
C	20,4 ± 0,5	19,9	20,9
D	8 ± 0,15	7,85	8,15
E	12,6 ± 0,15	12,45	12,75
F	38,1 ± 0,2	37,9	38,3
G	4 ^{+0,2 / -0,05}	3,95	4,2
H	4 ± 0,2	3,8	4,2
I	25,4 ± 0,2	25,2	25,6
J	UNC 6-32	-	-
K	4,2 ± 0,2	4,0	4,4
L	27,2 ± 0,2	27,0	27,4
M	11,6 ± 0,5	11,1	12,1
N	5,8 ± 0,4	5,4	6,2
O	0,25 ± 0,02	0,23	0,27
P	0,45 ± 0,03	0,42	0,48
Q	2,54 ± 0,3	2,24	2,84
R	2,54 ± 0,5	2,04	3,04
S	2,54 ± 0,25	2,29	2,79
T	5,08 ± 0,25	4,83	5,33
U	5,08 ± 0,25	4,83	5,33

Pinning:

	1	2	3	4	5	6	7	8	9
	INPUT	GND	GND	+VB			GND	GND	OUTPUT

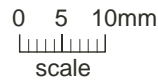

Notes:

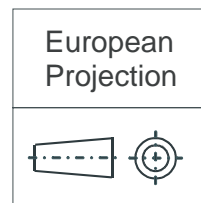

R3005300L



rfmd.com