



Features

- Excellent Linearity
- Superior Return Loss Performance
- Extremely Low Distortion
- Optimal Reliability
- Low Noise
- Unconditionally Stable Under all Terminations
- High Output Capability
- 25.0dB Min. Gain at 1003MHz
- 440mA Max. at 24V_{DC}

Applications

- 40MHz to 1003MHz CATV Amplifier Systems

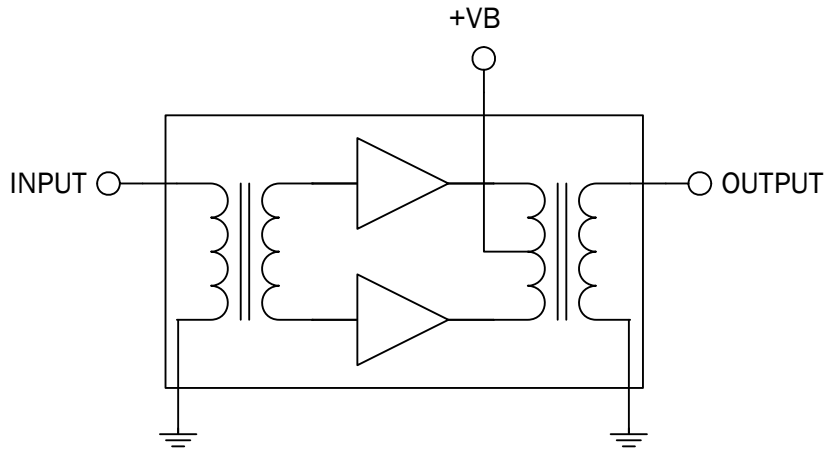

Functional Block Diagram

Product Description

The RFPD2670 is a hybrid power doubler amplifier module. The part employs GaAs MESFET, GaAs pHEMT and GaN HEMT die, has high output capability, and is operated from 40MHz to 1003MHz. It provides excellent linearity and superior return loss performance with low noise and optimal reliability.

Optimum Technology Matching® Applied

- | | | | |
|---|--------------------------------------|--|--|
| <input type="checkbox"/> GaAs HBT | <input type="checkbox"/> SiGe BiCMOS | <input checked="" type="checkbox"/> GaAs pHEMT | <input checked="" type="checkbox"/> GaN HEMT |
| <input checked="" type="checkbox"/> GaAs MESFET | <input type="checkbox"/> Si BiCMOS | <input type="checkbox"/> Si CMOS | <input type="checkbox"/> BiFET HBT |
| <input type="checkbox"/> InGaP HBT | <input type="checkbox"/> SiGe HBT | <input type="checkbox"/> Si BJT | |

RF MICRO DEVICES®, RFMD®, Optimum Technology Matching®, Enabling Wireless Connectivity™, PowerStar®, POLARIS™ TOTAL RADIO™ and UltimateBlue™ are trademarks of RFMD, LLC. BLUETOOTH is a trademark owned by Bluetooth SIG, Inc., U.S.A. and licensed for use by RFMD. All other trade names, trademarks and registered trademarks are the property of their respective owners. ©2012, RF Micro Devices, Inc.

Absolute Maximum Ratings

Parameter	Rating	Unit
RF Input Voltage (single tone)	70	dBmV
DC Supply Over-Voltage (5 minutes)	30	V
Storage Temperature	-40 to +100	°C
Operating Mounting Base Temperature	-30 to +100	°C



Caution! ESD sensitive device.

Exceeding any one or a combination of the Absolute Maximum Rating conditions may cause permanent damage to the device. Extended application of Absolute Maximum Rating conditions to the device may reduce device reliability. Specified typical performance or functional operation of the device under Absolute Maximum Rating conditions is not implied.

The information in this publication is believed to be accurate and reliable. However, no responsibility is assumed by RF Micro Devices, Inc. ("RFMD") for its use, nor for any infringement of patents, or other rights of third parties, resulting from its use. No license is granted by implication or otherwise under any patent or patent rights of RFMD. RFMD reserves the right to change component circuitry, recommended application circuitry and specifications at any time without prior notice.



RoHS (Restriction of Hazardous Substances): Compliant per EU Directive 2002/95/EC.

Parameter	Specification			Unit	Condition
	Min.	Typ.	Max.		
Overall					$V_B = 24V$; $T_{MB} = 30^\circ C$; $Z_S = Z_L = 75\Omega$
Power Gain	23.5	24.0	24.5	dB	$f = 50MHz$
	24.5	25.0	26.0	dB	$f = 1003MHz$
Slope ^[1]	0.5	1.0	2.0	dB	$f = 40MHz$ to $1003MHz$
Flatness of Frequency Response			0.8	dB	$f = 40MHz$ to $1003MHz$
Input Return Loss	-20			dB	$f = 40MHz$ to $320MHz$
	-18			dB	$f = 320MHz$ to $640MHz$
	-17			dB	$f = 640MHz$ to $870MHz$
	-16			dB	$f = 870MHz$ to $1003MHz$
Output Return Loss	-20			dB	$f = 40MHz$ to $320MHz$
	-19			dB	$f = 320MHz$ to $640MHz$
	-18			dB	$f = 640MHz$ to $870MHz$
	-17			dB	$f = 870MHz$ to $1003MHz$
Noise Figure		5.0	5.5	dB	$f = 50MHz$ to $1003MHz$
Total Current Consumption (DC)		420.0	440.0	mA	
Distortion data 40MHz to 550MHz					$V_B = 24V$; $T_{MB} = 30^\circ C$; $Z_S = Z_L = 75\Omega$
CTB		-75	-70	dBc	$V_O = 56.4dBmV$ at $1000MHz$, $13.4dB$ extrapolated tilt, 79 analog channels plus 75 digital channels (-6dB offset) ^[2]
XMOD		-70	-65	dBc	$V_O = 56.4dBmV$ at $1000MHz$, $13.4dB$ extrapolated tilt, 79 analog channels plus 75 digital channels (-6dB offset) ^[2]
CSO		-70	-65	dBc	$V_O = 56.4dBmV$ at $1000MHz$, $13.4dB$ extrapolated tilt, 79 analog channels plus 75 digital channels (-6dB offset) ^[2]
CIN	60	66		dB	$V_O = 56.4dBmV$ at $1000MHz$, $13.4dB$ extrapolated tilt, 79 analog channels plus 75 digital channels (-6dB offset) ^[2]

[1] The slope is defined as the difference between the gain at the start frequency and the gain at the stop frequency.

[2] 79 analog channels, NTSC frequency raster: 55.25MHz to 547.25MHz, +43dBmV to +50dBmV tilted output level, plus 75 digital channels, -6dB offset relative to the equivalent analog carrier. Composite Second Order (CSO) - The CSO parameter (both sum and difference products) is defined by the NCTA. Composite Triple Beat (CTB) - The CTB parameter is defined by the NCTA. Cross Modulation (XMOD) - Cross modulation (XMOD) is measured at baseband (selective voltmeter method), referenced to 100% modulation of the carrier being tested. Carrier to Intermodulation Noise (CIN) - The CIN parameter is defined by ANSI/SCTE 17 (Test procedure for carrier to noise).

Package Drawing

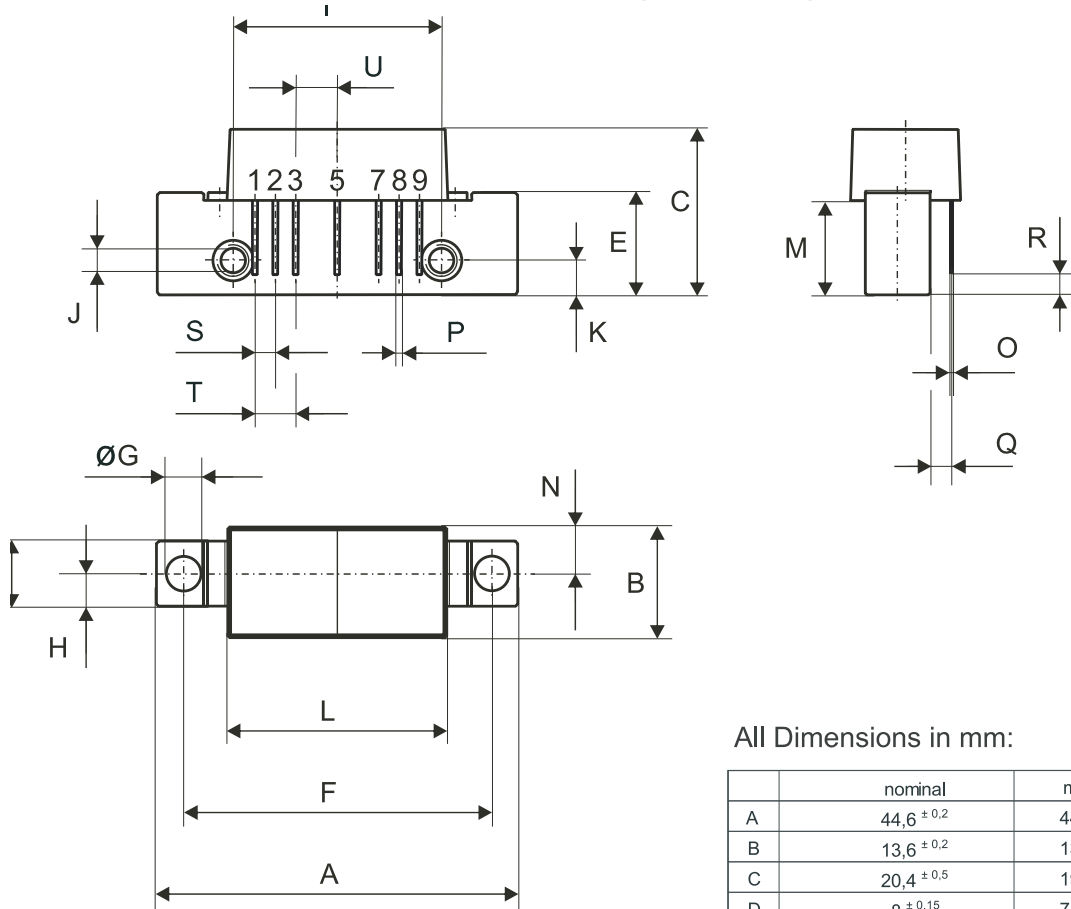

All Dimensions in mm:

	nominal	min	max
A	44,6 ± 0,2	44,4	44,8
B	13,6 ± 0,2	13,4	13,8
C	20,4 ± 0,5	19,9	20,9
D	8 ± 0,15	7,85	8,15
E	12,6 ± 0,15	12,45	12,75
F	38,1 ± 0,2	37,9	38,3
G	4 ^{+0,2 / -0,05}	3,95	4,2
H	4 ± 0,2	3,8	4,2
I	25,4 ± 0,2	25,2	25,6
J	UNC 6-32	-	-
K	4,2 ± 0,2	4,0	4,4
L	27,2 ± 0,2	27,0	27,4
M	11,6 ± 0,5	11,1	12,1
N	5,8 ± 0,4	5,4	6,2
O	0,25 ± 0,02	0,23	0,27
P	0,45 ± 0,03	0,42	0,48
Q	2,54 ± 0,3	2,24	2,84
R	2,54 ± 0,5	2,04	3,04
S	2,54 ± 0,25	2,29	2,79
T	5,08 ± 0,25	4,83	5,33
U	5,08 ± 0,25	4,83	5,33

Pinning:

	1	2	3	4	5	6	7	8	9
INPUT									
GND									
GND									
+VB									
GND									
GND									
OUTPUT									

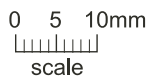

Notes:

