



Package: SOT-115J



Product Description

The D10040200PH1 is a Hybrid Power Doubler amplifier module. The part employs GaAs pHEMT and GaN HEMT die and is operated from 45 MHz to 1000 MHz. It provides high output capability, excellent linearity, and superior return loss performance with low noise and optimal reliability.

Features

- Low Current
- Excellent Linearity
- Superior Return Loss Performance
- Extremely Low Distortion
- Optimal Reliability
- Extremely Low Noise
- Unconditionally Stable Under All Terminations
- High Output Capability
- 20.0dB Min. Gain at 1GHz
- 450mA Max. at 24VDC

Applications

- 45 MHz to 1000 MHz CATV Amplifier Systems

Optimum Technology Matching® Applied

- GaAs HBT
- GaAs MESFET
- InGaP HBT
- SiGe BiCMOS
- Si BiCMOS
- SiGe HBT
- GaAs pHEMT
- Si CMOS
- Si BJT
- GaN HEMT
- RF MEMS

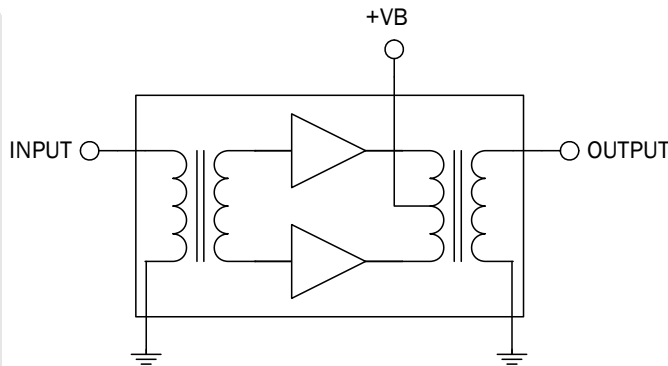

| Parameter | Specification | | | Unit | Condition |
|--------------------------------|---------------|-------|-------|------|--|
| | Min. | Typ. | Max. | | |
| Overall | | | | | $V_B = 24V; T_{MB} = 30^\circ C; Z_S = Z_L = 75\Omega$ |
| Power Gain | 18.5 | 19.0 | 19.5 | dB | f = 45 MHz |
| | 20.0 | 20.5 | 21.5 | dB | f = 1000 MHz |
| Slope ^[1] | 1.0 | 1.5 | 2.5 | dB | f = 45 MHz to 1000 MHz |
| Flatness of Frequency Response | | | 0.8 | dB | f = 45 MHz to 1000 MHz (Peak to Valley) |
| Input Return Loss | 20 | | | dB | f = 45 MHz to 320 MHz |
| | 19 | | | dB | f = 320 MHz to 640 MHz |
| | 18 | | | dB | f = 640 MHz to 870 MHz |
| | 16 | | | dB | f = 870 MHz to 1000 MHz |
| Output Return Loss | 20 | | | dB | f = 45 MHz to 320 MHz |
| | 19 | | | dB | f = 320 MHz to 640 MHz |
| | 18 | | | dB | f = 640 MHz to 870 MHz |
| | 17 | | | dB | f = 870 MHz to 1000 MHz |
| Noise Figure | | 3.0 | 4.0 | dB | f = 50 MHz to 1000 MHz |
| Total Current Consumption (DC) | | 430.0 | 450.0 | mA | |

1. The slope is defined as the difference between the gain at the start frequency and the gain at the stop frequency.

Absolute Maximum Ratings

| Parameter | Rating | Unit |
|-------------------------------------|-------------|------|
| RF Input Voltage (single tone) | 65 | dBmV |
| DC Supply Over-Voltage (5 minutes) | 30 | V |
| Storage Temperature | -40 to +100 | °C |
| Operating Mounting Base Temperature | -30 to +100 | °C |



Caution! ESD sensitive device.

Exceeding any one or a combination of the Absolute Maximum Rating conditions may cause permanent damage to the device. Extended application of Absolute Maximum Rating conditions to the device may reduce device reliability. Specified typical performance or functional operation of the device under Absolute Maximum Rating conditions is not implied.

RoHS status based on EU Directive 2002/95/EC (at time of this document revision).

The information in this publication is believed to be accurate and reliable. However, no responsibility is assumed by RF Micro Devices, Inc. ("RFMD") for its use, nor for any infringement of patents, or other rights of third parties, resulting from its use. No license is granted by implication or otherwise under any patent or patent rights of RFMD. RFMD reserves the right to change component circuitry, recommended application circuitry and specifications at any time without prior notice.

| Parameter | Specification | | | Unit | Condition |
|--|---------------|------|------|------|--|
| | Min. | Typ. | Max. | | |
| Distortion data 40 MHz to 550 MHz | | | | | $V_B = 24V, T_{MB} = 30^\circ C, Z_S = Z_L = 75\Omega$ |
| CTB | | -77 | -74 | dBc | 79 ch 7 dB tilted; $V_O = 50\text{dBmV}$ at 550 MHz, plus 75 digital channels (-6dB offset) ^[2] |
| XMOD | | -71 | -68 | dBc | 79 ch 7 dB tilted; $V_O = 50\text{dBmV}$ at 550 MHz, plus 75 digital channels (-6dB offset) ^[2] |
| CSO | | -71 | -68 | dBc | 79 ch 7 dB tilted; $V_O = 50\text{dBmV}$ at 550 MHz, plus 75 digital channels (-6dB offset) ^[2] |
| CIN | 65 | 68 | | dB | 79 ch 7 dB tilted; $V_O = 50\text{dBmV}$ at 550 MHz, plus 75 digital channels (-6dB offset) ^[2] |

2. 79 analog channels, NTSC frequency raster: 55.25 MHz to 547.25 MHz, +43 dBmV to +50 dBmV tilted output level, plus 75 digital channels, -6 dB offset relative to the equivalent analog carrier.

Composite Second Order (CSO) - The CSO parameter (both sum and difference products) is defined by the NCTA.

Composite Triple Beat (CTB) - The CTB parameter is defined by the NCTA.

Cross Modulation (XMOD) - Cross modulation (XMOD) is measured at baseband (selective voltmeter method), referenced to 100% modulation of the carrier being tested.

Carrier to Intermodulation Noise (CIN) - The CIN parameter is defined by ANSI/SCTE 17 (Test Procedure for Carrier to Noise)

D10040200PH1

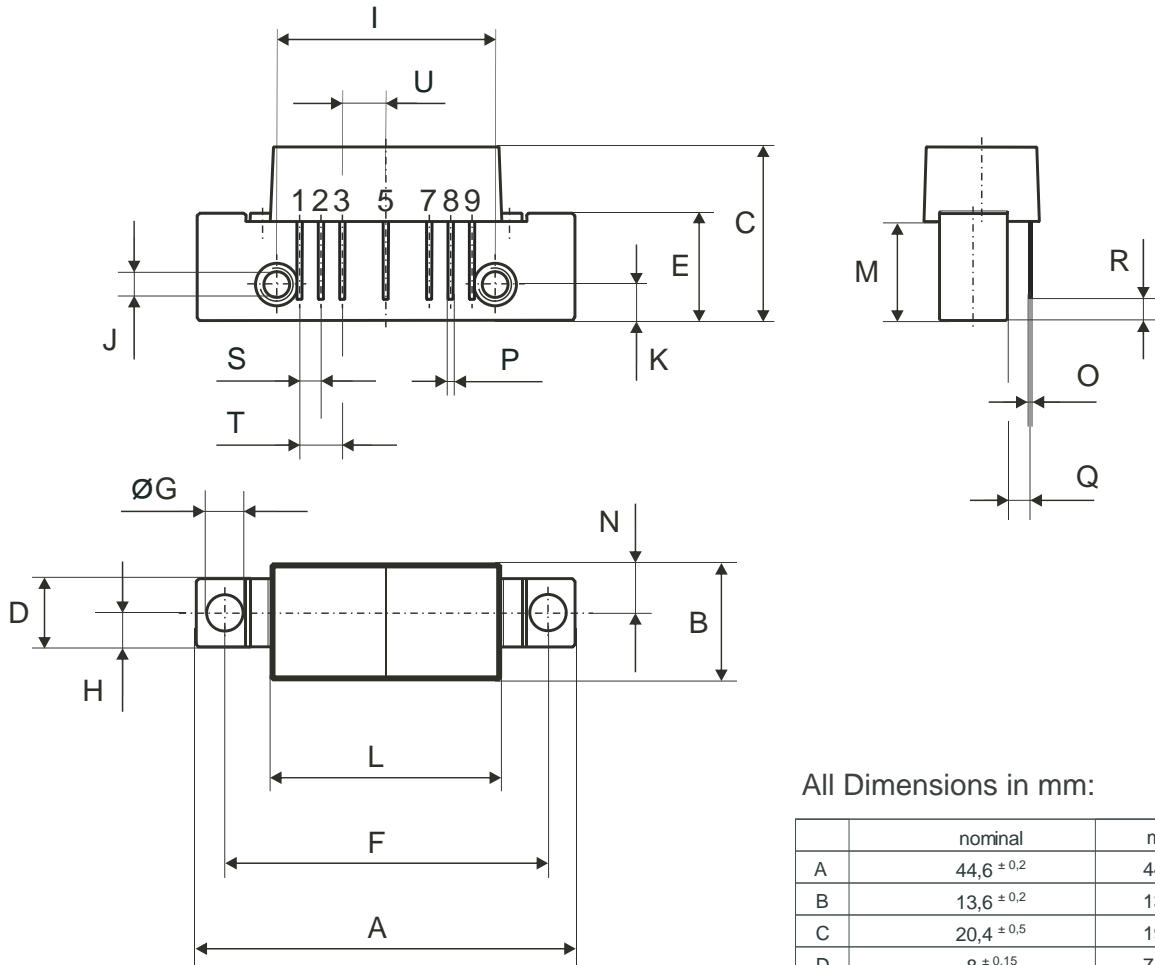

All Dimensions in mm:

| | nominal | min | max |
|---|---------------------------|-------|-------|
| A | 44,6 ± 0,2 | 44,4 | 44,8 |
| B | 13,6 ± 0,2 | 13,4 | 13,8 |
| C | 20,4 ± 0,5 | 19,9 | 20,9 |
| D | 8 ± 0,15 | 7,85 | 8,15 |
| E | 12,6 ± 0,15 | 12,45 | 12,75 |
| F | 38,1 ± 0,2 | 37,9 | 38,3 |
| G | 4 ^{+0,2 / -0,05} | 3,95 | 4,2 |
| H | 4 ± 0,2 | 3,8 | 4,2 |
| I | 25,4 ± 0,2 | 25,2 | 25,6 |
| J | UNC 6-32 | - | - |
| K | 4,2 ± 0,2 | 4,0 | 4,4 |
| L | 27,2 ± 0,2 | 27,0 | 27,4 |
| M | 11,6 ± 0,5 | 11,1 | 12,1 |
| N | 5,8 ± 0,4 | 5,4 | 6,2 |
| O | 0,25 ± 0,02 | 0,23 | 0,27 |
| P | 0,45 ± 0,03 | 0,42 | 0,48 |
| Q | 2,54 ± 0,3 | 2,24 | 2,84 |
| R | 2,54 ± 0,5 | 2,04 | 3,04 |
| S | 2,54 ± 0,25 | 2,29 | 2,79 |
| T | 5,08 ± 0,25 | 4,83 | 5,33 |
| U | 5,08 ± 0,25 | 4,83 | 5,33 |

Pinning:

| | 1 | 2 | 3 | 4 | 5 | 6 | 7 | 8 | 9 |
|--------|---|---|---|---|---|---|---|---|---|
| INPUT | | | | | | | | | |
| GND | | | | | | | | | |
| GND | | | | | | | | | |
| +VB | | | | | | | | | |
| GND | | | | | | | | | |
| GND | | | | | | | | | |
| OUTPUT | | | | | | | | | |

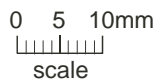

Notes:

