



**Features**

- 3mm x 3mm LNA/Mixer Solution
- Adjustable LNA and Mixer Current/IIP3
- Meets IMD Tests with Three Gain States/Two Logic Control Pins
- Integrated TX LO Buffer Amplifier
- Full ESD Protection on all Pins

**Applications**

- CDMA/JCDMA Cellular Systems
- CDMA450 Handsets/Data Cards
- AMPS Cellular Systems
- General Purpose LNA and Downconverter
- Commercial and Consumer Systems
- Portable Battery-Powered Equipment

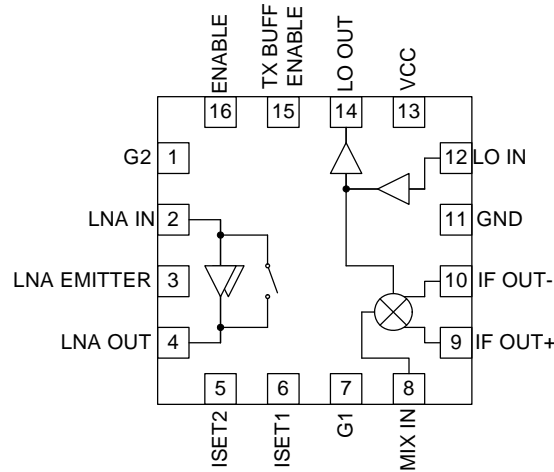

Functional Block Diagram

**Product Description**

The RF2861 is a receiver front-end for CDMA cellular applications, including JCDMA and CDMA450. It is designed to amplify and downconvert RF signals, using a three gain state LNA to obtain 17dB of stepped gain control. Features include digital control of LNA gain and power down mode, along with an integrated TX LO buffer amplifier. Another feature of the chip is adjustable IIP3 of the LNA and mixer using off-chip current setting resistors to allow for minimum DC current consumption. Noise figure, IIP3, and other specs are designed to be compatible with the TIA/EIA 98D standard for CDMA cellular communications. The IC is manufactured on an advanced Silicon Germanium Bi-CMOS process and is in a 3mm x 3mm, 16-pin, QFN.

**Ordering Information**

RF2861SQ	Sample bag with 25 pieces
RF2861SR	7" Reel with 100 pieces
RF2861TR7	7" Reel with 2500 pieces
RF2861PCK-410	460MHz to 900MHz PCBA with 5-piece sample bag

**Optimum Technology Matching® Applied**

- |                                      |   |                                     |                                    |
|--------------------------------------|---|-------------------------------------|------------------------------------|
| <input type="checkbox"/> GaAs HBT    | <input checked="" type="checkbox"/> SiGe BiCMOS | <input type="checkbox"/> GaAs pHEMT | <input type="checkbox"/> GaN HEMT  |
| <input type="checkbox"/> GaAs MESFET | <input type="checkbox"/> Si BiCMOS              | <input type="checkbox"/> Si CMOS    | <input type="checkbox"/> BiFET HBT |
| <input type="checkbox"/> InGaP HBT   | <input type="checkbox"/> SiGe HBT               | <input type="checkbox"/> Si BJT     | <input type="checkbox"/> LD MOS    |

RF MICRO DEVICES®, RFMD®, Optimum Technology Matching®, Enabling Wireless Connectivity™, PowerStar®, POLARIS™ TOTAL RADIO™ and UltimateBlue™ are trademarks of RFMD, LLC. BLUETOOTH is a trademark owned by Bluetooth SIG, Inc., U.S.A. and licensed for use by RFMD. All other trade names, trademarks and registered trademarks are the property of their respective owners. ©2006, RF Micro Devices, Inc.

## Absolute Maximum Ratings

Parameter	Rating	Unit
Supply Voltage	-0.5 to +5.0	V <sub>DC</sub>
Input LO and RF Levels	+6	dBm
Operating Ambient Temperature	-40 to +85	°C
Storage Temperature	-40 to +150	°C



**Caution!** ESD sensitive device.

Exceeding any one or a combination of the Absolute Maximum Rating conditions may cause permanent damage to the device. Extended application of Absolute Maximum Rating conditions to the device may reduce device reliability. Specified typical performance or functional operation of the device under Absolute Maximum Rating conditions is not implied.

The information in this publication is believed to be accurate and reliable. However, no responsibility is assumed by RF Micro Devices, Inc. ("RFMD") for its use, nor for any infringement of patents, or other rights of third parties, resulting from its use. No license is granted by implication or otherwise under any patent or patent rights of RFMD. RFMD reserves the right to change component circuitry, recommended application circuitry and specifications at any time without prior notice.



RoHS (Restriction of Hazardous Substances): Compliant per EU Directive 2002/95/EC.

Parameter	Specification			Unit	Condition
	Min.	Typ.	Max.		
<b>Overall</b>					T = 25 °C, V <sub>CC</sub> = 2.75V
RF Frequency Range		460 to 900		MHz	
IF Frequency Range	0.1		400	MHz	
<b>Power Supply</b>					
Supply Voltage	2.65	2.75	3.15	V	
Logic High	1.8			V	
Logic Low			0.4	V	
<b>Cellular CDMA Band</b>					Freq = 869MHz to 894MHz
<b>JCDMA Band</b>					Freq = 832MHz to 870MHz
<b>LNA (High Gain)</b>					LNA 50Ω match
Gain	13.0	14.5	16.0	dB	
Noise Figure		1.1	1.3	dB	
Input IP3	9.0	11.0		dBm	
Current		7.0		mA	
Isolation	18.5			dB	
<b>LNA (Mid Gain)</b>					
Gain	4.0	6.0	7.0	dB	
Noise Figure		3.0	3.3	dB	
Input IP3	7.0	9.0		dBm	
Current		3.5		mA	
Isolation	12.5			dB	
<b>LNA (Low Gain)</b>					
Gain	-4.0	-2.5	-1.0	dB	
Noise Figure		2.5	4.0	dB	
Input IP3	+25.0	+27.0		dBm	
Current		0		mA	
Isolation	1.0			dB	
<b>Mixer - CDMA/JCDMA/FM</b>					IF tune set for nominal mixer gain, high IIP3
Gain	9.0	10.5	12.0	dB	
Noise Figure		7.5	8.0	dB	184MHz IF (NF = 8.3dB, 85MHz IF)
Input IP3	+6.0	+8.5		dBm	
LO to RF Isolation	36			dB	LO = 1064MHz

Parameter	Specification			Unit	Condition
	Min.	Typ.	Max.		
<b>Mixer - CDMA/JCDMA/FM</b>					
Gain		13.0		dB	IF tune set for high mixer gain, nominal IIP3
Noise Figure		7.5		dB	184MHz IF (NF = 8.3dB, 85MHz IF)
Input IP3		+6.5		dBm	
LO to RF Isolation	36			dB	LO = 1064MHz
<b>Cascade - High Gain</b>					
Current		25	30	mA	TX LO Buffer Off
<b>Cellular CDMA Band JCDMA Band, cont'd</b>					
<b>Other</b>					
LO-IF Isolation	30			dB	LO = 1064MHz
RF-IF Isolation	45			dB	
LNA Out to Mixer In Isolation	45			dB	
LO-LNA In Isolation, Any State	40			dB	LO = 1064MHz
<b>Control Lines</b>					
Input Capacitance			1	pF	G1, G2, ENABLE, TX BUFF ENABLE
<b>Local Oscillator Input</b>					
Cellular - CDMA or FM					
Input Power	-10	-4	0	dBm	
Input Frequency	685		710	MHz	IF = 184MHz
	1053		1078	MHz	IF = 184MHz
	784		809	MHz	IF = 85MHz
	954		979	MHz	IF = 85MHz
Cellular - JCDMA					
Input Power	-10	-4	0	dBm	
Input Frequency	722		760	MHz	IF = 110MHz
	942		980	MHz	IF = 110MHz
CDMA450					
Input Power	-10	-4	0	dBm	
Input Frequency	505		575	MHz	IF = 85MHz
<b>CDMA450 Band</b>					
					Freq = 463MHz to 467MHz
<b>LNA (High Gain)</b>					
					LNA 50Ω match
Gain		15.0		dB	
Noise Figure		1.4		dB	
Input IP3		+8.0		dBm	
Current		8.7		mA	
Isolation	18.5			dB	
<b>LNA (Mid Gain)</b>					
Gain		+2.5		dB	
Noise Figure		2.9		dB	
Input IP3		+14.0		dBm	
Current		4.7		mA	
Isolation	12.5			dB	

Parameter	Specification			Unit	Condition
	Min.	Typ.	Max.		
<b>LNA (Low Gain)</b>					
Gain		-4.0		dB	
Noise Figure		4.0		dB	
Input IP3		+25.0		dBm	
Current		0		mA	
Isolation	1.0			dB	
<b>Mixer</b>					
					IF tune set for high mixer gain, nominal IIP3
Gain		12.0		dB	
Noise Figure		7.5		dB	
Input IP3		5.0		dBm	
LO to RF Isolation	36			dB	LO = 549MHz
<b>CDMA450 Isolation</b>					
LO-IF Isolation	25			dB	LO = 549MHz
RF-IF Isolation	40			dB	
LNA Out to Mixer In Isolation	40			dB	
LO-LNA In Isolation, Any State	30			dB	LO = 549MHz
<b>TX (Local Oscillator) Buffer Output</b>					
Cellular - CDMA or FM					
Output Power	-7	-5	-3	dBm	Single-ended 50Ω load
Output Frequency	685		710	MHz	IF = 184MHz
	1053		1078	MHz	IF = 184MHz
	784		809	MHz	IF = 85MHz
	954		979	MHz	IF = 85MHz
Current Consumption		2		mA	
Cellular - JCDMA					
Output Power	-7	-5	-3	dBm	Single-ended 50Ω load
Output Frequency	722		760	MHz	IF = 110MHz
	942		980	MHz	IF = 110MHz
Current Consumption		2		mA	
CDMA450					
Output Power	-7	-5	-3	dBm	Single-ended 50Ω load
Output Frequency	505		575	MHz	IF = 85MHz
Current Consumption		2		mA	

**Gain Control Logic Table**

Gain State	ENABLE	G1	G2
High Gain	1	0	0
Mid Gain	1	1	0
Low Gain	1	1	1
Low Gain (alternate)	1	0	1

NOTE: All IDC current numbers include bias circuitry current of 1.5mA to 2.0mA (dependent on mode).  
TX Buffer On: Add 2mA to total current.

**Cell Band Cascaded Performance High Mixer Gain Nominal IIP3**

(Typical Values for  $V_{CC} = 2.75V$ )

Parameter	CELL CDMA		
	LNA (High Gain)	LNA (Mid Gain)	LNA (Low Gain)
Cascaded:			
Gain (dB)	25.0	16.5	8.0
Noise Figure (dB)	2.1	6.3	12.5
Input IP3 (dBm)	-5.6	+2.0	+11.4
Total Current (mA)	25.0	21.5	18.0

NOTES:

1. Assumes 2.5dB image filter insertion loss. The TX Buffer is off. NOTE:
2. All total current numbers include bias circuitry current of 1.5 mA to 2.0 mA (dependent on mode).

**Cell Band Cascaded Performance Nominal Mixer Gain High IIP3**

(Typical Values for  $V_{CC} = 2.75V$ )

Parameter	CELL CDMA		
	LNA (High Gain)	LNA (Mid Gain)	LNA (Low Gain)
Cascaded:			
Gain (dB)	22.5	14.0	5.5
Noise Figure (dB)	2.1	6.3	12.5
Input IP3 (dBm)	-3.7	+3.5	+13.3
Total Current (mA)	25.0	21.5	18.0

NOTE: Assumes 2.5dB image filter insertion loss. The TX Buffer is off.

**CDMA450 Band Cascaded Performance**

(Typical Values for  $V_{CC} = 2.75V$ )

Parameter	CDMA450		
	LNA (High Gain)	LNA (Mid Gain)	LNA (Low Gain)
Cascaded:			
Gain (dB)	24.5	12.0	5.5
Noise Figure (dB)	2.2	8.5	14.0
Input IP3 (dBm)	-7.6	+4.5	+11.3
Total Current (mA)	29.5	25	21

NOTE: Assumes 2.5dB image filter insertion loss. The TX Buffer is off.

## Pin Names and Descriptions

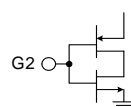
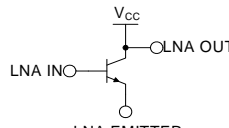
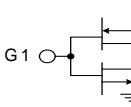
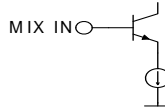
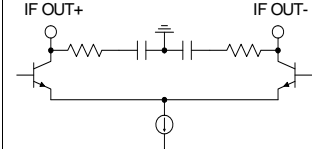
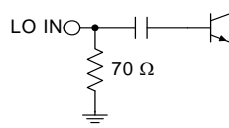
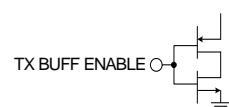
Pin	Function	Type	Description	Interface Schematic
1	G2	DI	Gain control logic input. See logic control table.	
2	LNA IN	AI	Cellular LNA input.	
3	LNA EMITTER	AO	Cellular LNA emitter. A small inductor connects this pin to ground. Cellular LNA gain can be adjusted by the inductance.	See pin 2.
4	LNA OUT	AO	Cellular LNA output. Simple external L-C components required for matching and VCC supply.	See pin 2.
5	ISET2	AO	An external resistor connected to this pin sets the current of the mixer. Increasing resistance decreases current.	
6	ISET1	AO	An external resistor connected to this pin sets the current of the LNA. Increasing resistance decreases current.	
7	G1	DI	Gain control logic input. See logic control table.	
8	MIX IN	AI	Cellular mixer RF single-end input.	
9	IF OUT+	AO	CDMA IF output. Open collector.	
10	IF OUT-	AO	CDMA IF output. Open collector.	See pin 9.
11	GND	P	Ground.	
12	LO IN	AI	LO single-end input. Matched to 50Ω.	
13	VCC	P	LO amplifier VCC external bypass capacitor may be required.	
14	LO OUT	AO	LO output. Internal DC block. Drives 50Ω.	
15	TX BUFF ENABLE	DI	Logic input. High enables TX LO output buffer amplifiers.	

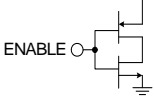
Pin	Function	Type	Description	Interface Schematic
16	ENABLE	DI	Logic input. Low level powers down the IC.	
Pkg Base	GND	P	Ground connection. The backside of the package should be soldered to a top side ground pad which is connected to the ground plane with multiple vias.	

Legend: DI = Digital Input from Baseband ChipAI = Analog Input  
P = V<sub>CC</sub> or GND AO = Analog Output

**Package Drawing**

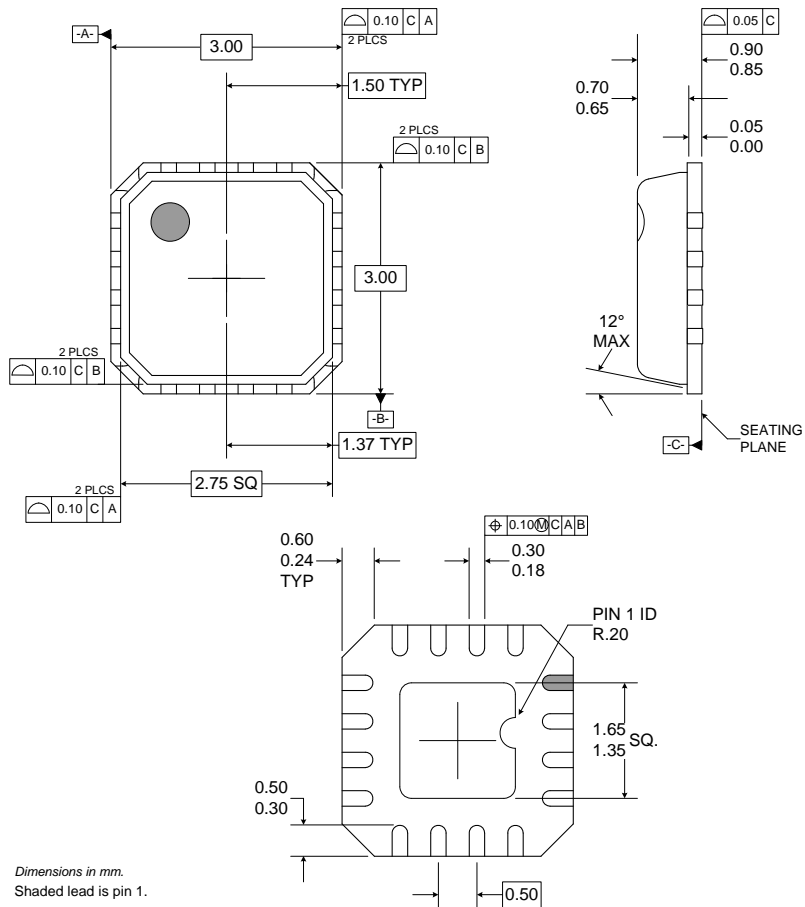

## Application Schematic Differential IF Matching

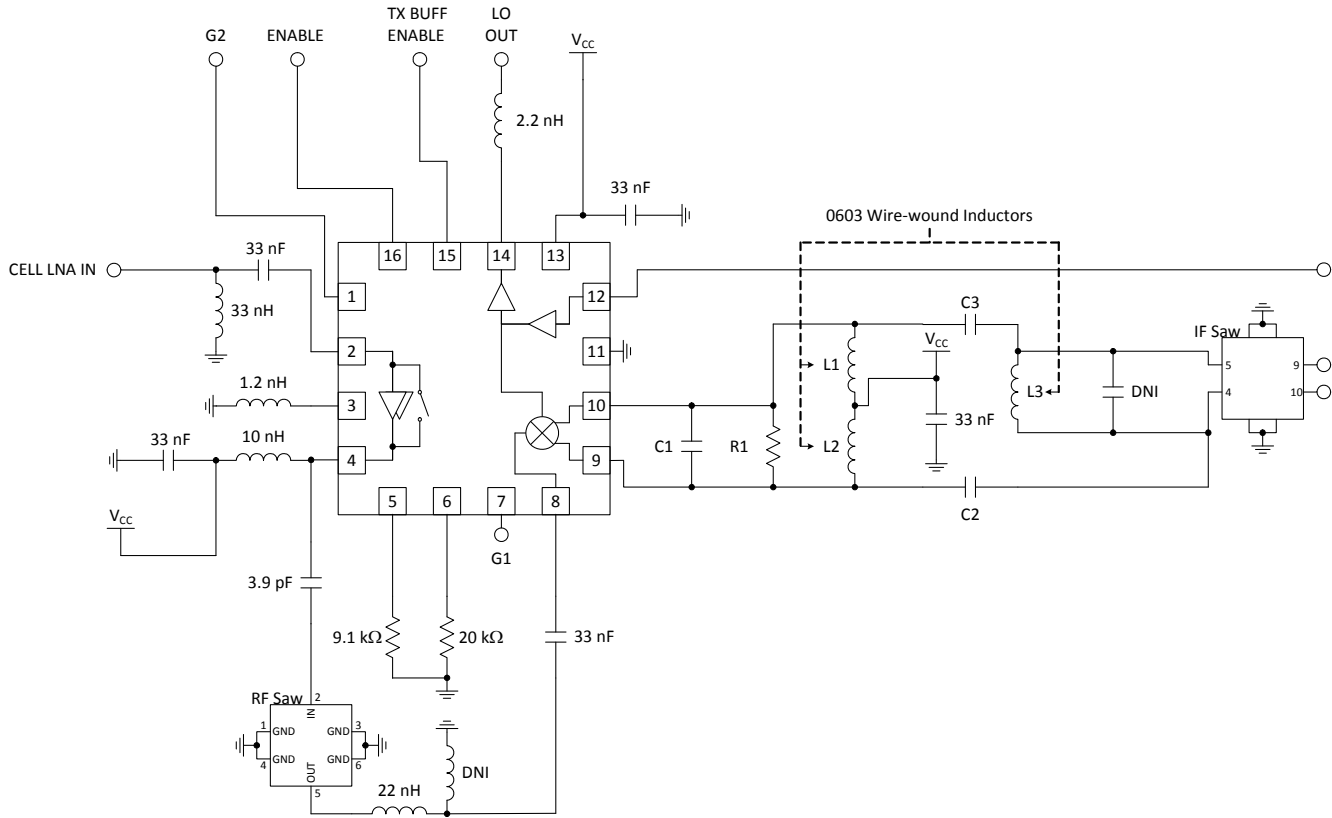

	C1	R1	L1	L2	C2	C3	L3	IF SAW FILTER
85MHz IF (LO Freq = 965MHz)	22pF	2.7kΩ	72nH	72nH	5.1pF	5.1pF	220nH	SAWTEK 855845
184MHz IF (LO Freq = 1064MHz)	5.0pF	2.7kΩ	55nH	55nH	10pF	10pF	43nH	EPCOS B4955



### Application Schematic Single-End Matching

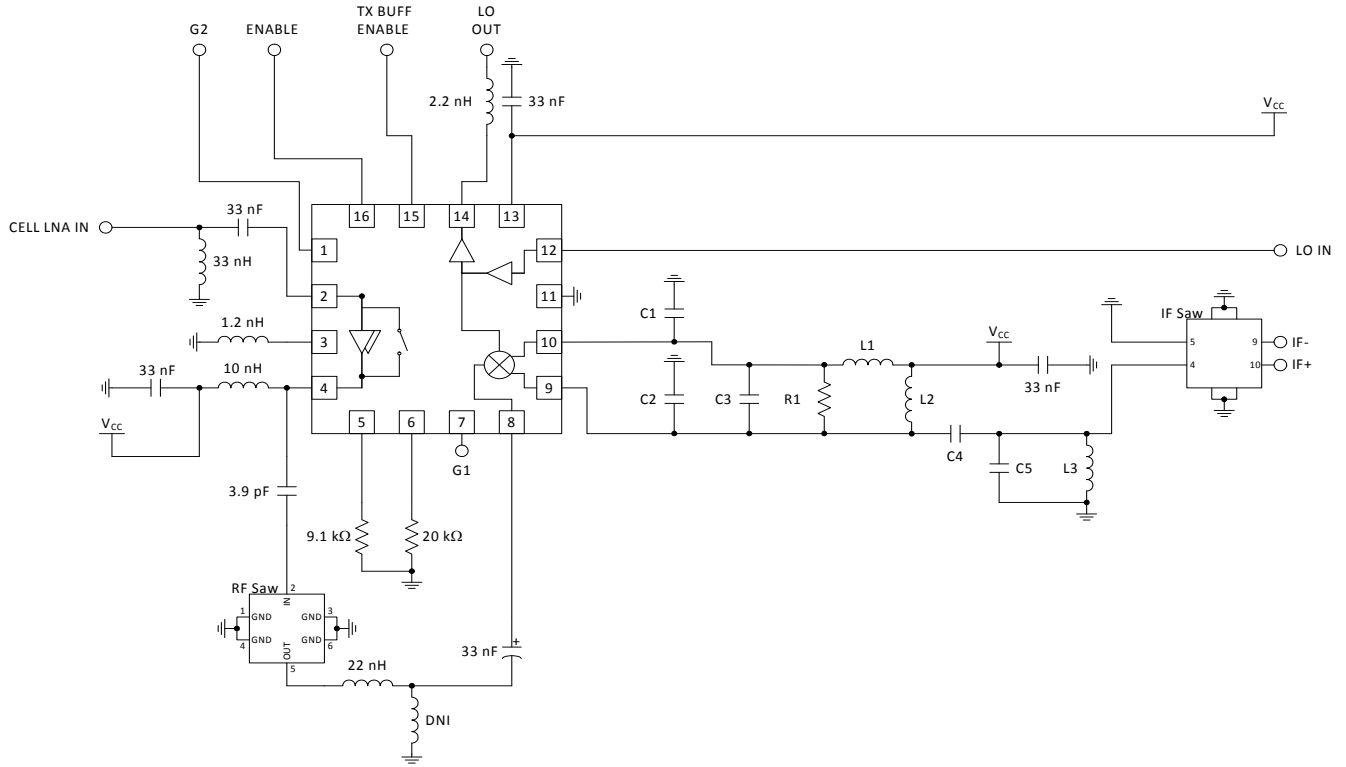

	C1	C2	C3	R1	L1	L2	C4	C5	L3	IF SAW FILTER
85MHz IF (LO Freq = 965MHz)	43pF	43pF	DNI	2.7kΩ	72nH	72nH	5.1pF	DNI	220nH	SAWTEK 855845
184MHz IF (LO Freq = 1064MHz)	13pF	13pF	DNI	2.7kΩ	55nH	55nH	10pF	DNI	43nH	EPCOS B4955

## Application Schematic

### Single-End Matching

### CDMA450 Band

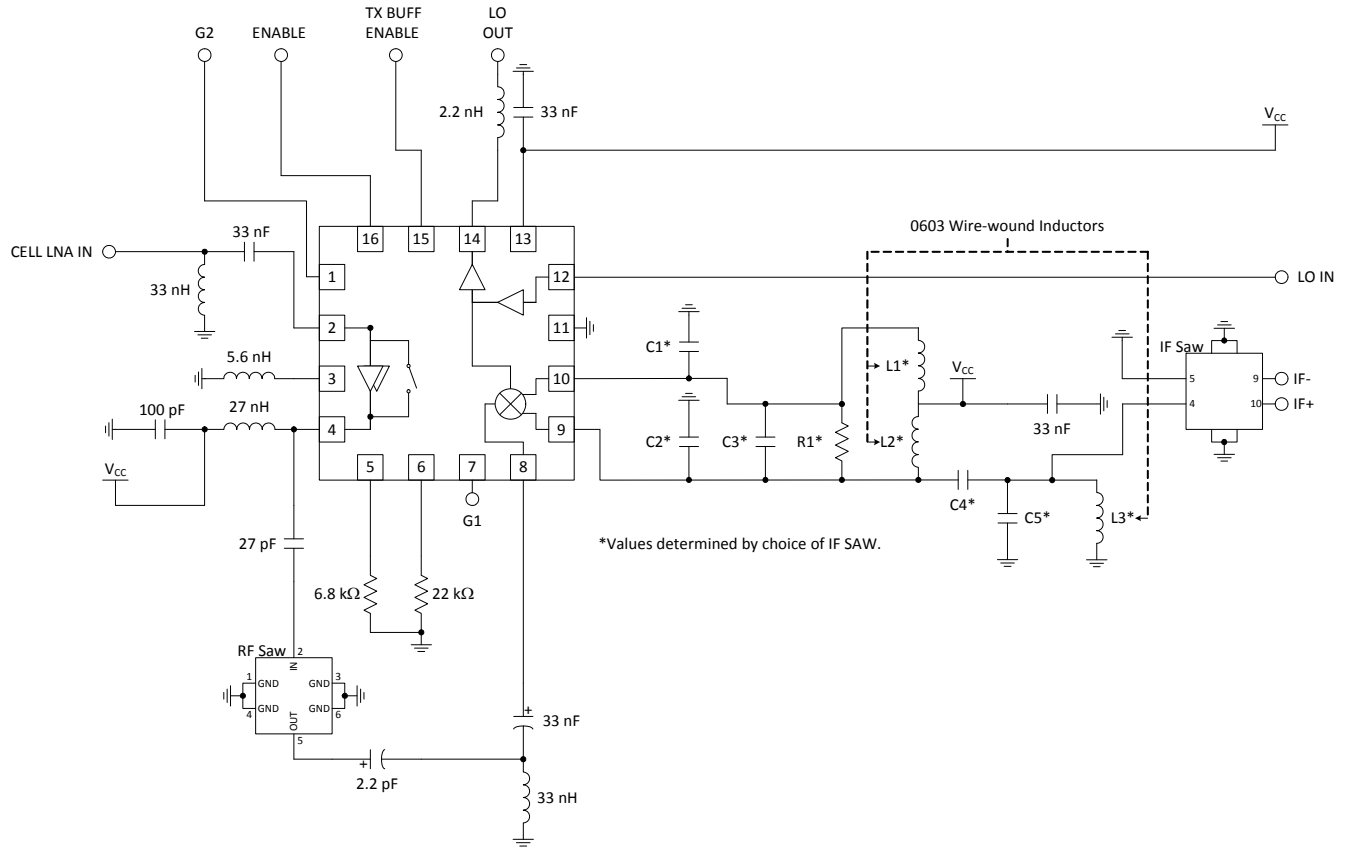

### Evaluation Board Schematic

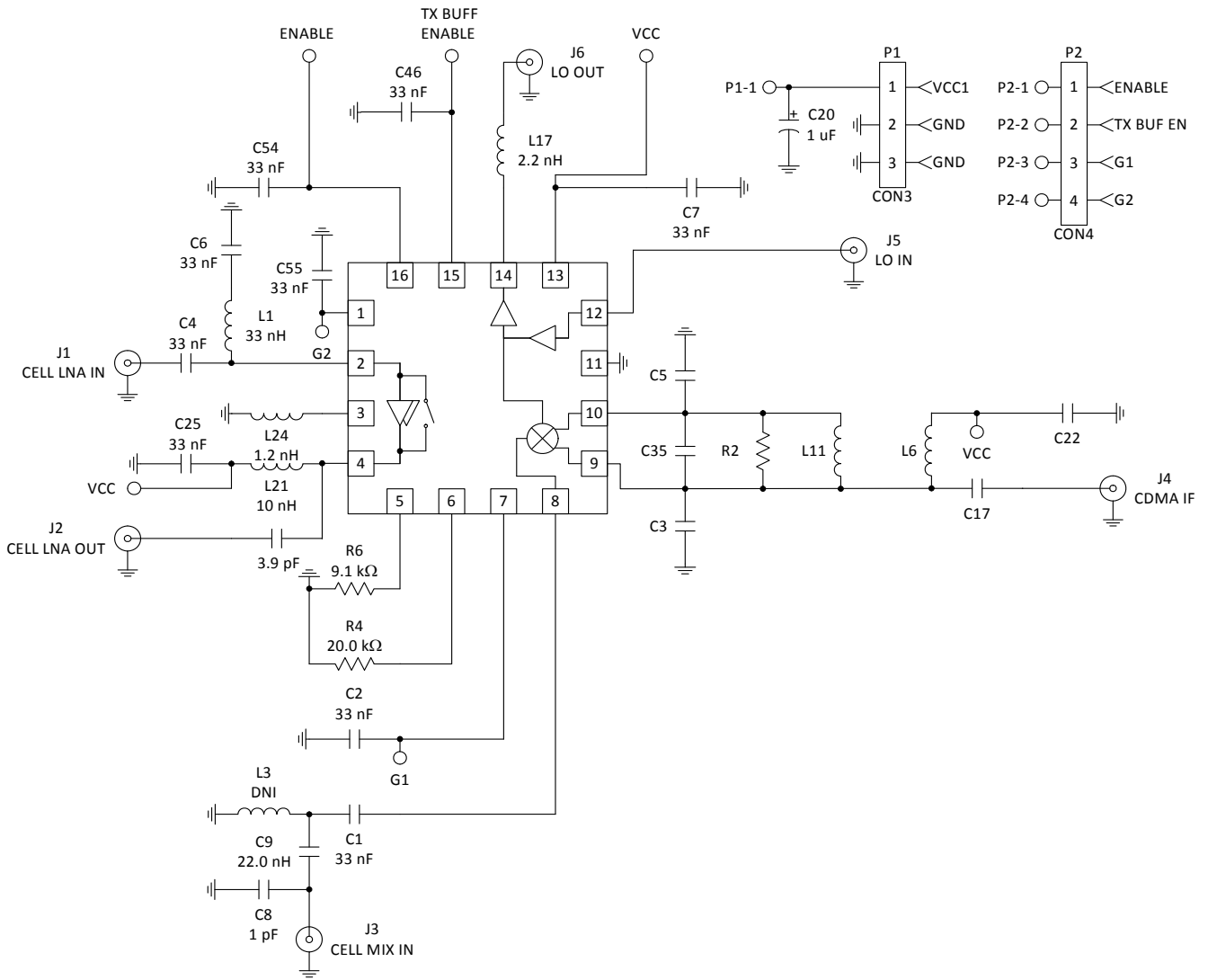

	C3	C5	C35	R2	L11	L6	C22	C17
85MHz IF (LO Freq = 965MHz)	47pF	47pF	DNI	5.1kΩ	150nH	180nH	33nF	8pF
184MHz IF (LO Freq = 1064MHz)	13pF	13pF	DNI	2.7kΩ	82nH	150nH	33nF	11pF

## Evaluation Board Schematic CDMA450 Band

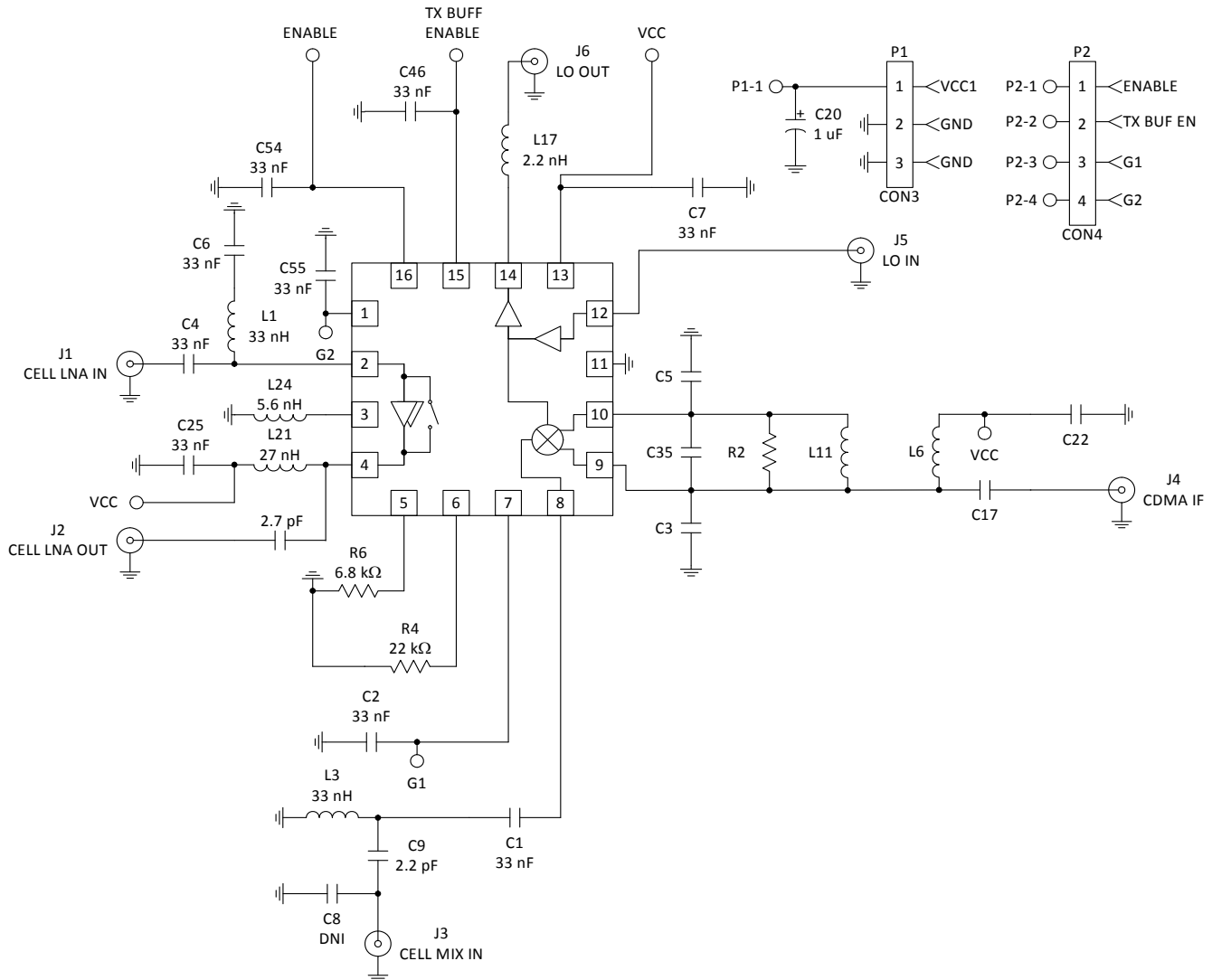

	C3	C5	C35	R2	L11	L6	C22	C17
85MHz IF (LO Freq = 549MHz)	91pF	91pF	DNI	6.8kΩ	68nH	270nH	33nF	27pF

## IF Output Interface Network

### Single-End IF Matching

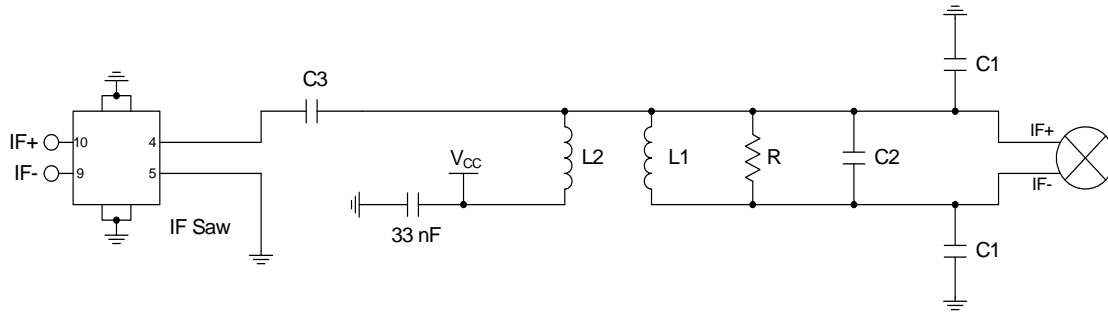

L1, C1, C2, and R form a current combiner which performs a differential to single-ended conversion at the IF frequency and sets the output impedance. In most cases, the resonance frequency is independent of R and can be set according to the following equation:

$$f_{IF} = \frac{1}{2\pi\sqrt{\frac{L1}{2}(C_1 + 2C_2 + C_{EQ})}}$$

Where  $C_{EQ}$  is the equivalent stray capacitance and capacitance looking into pins 9 and 10. An average value to use for  $C_{EQ}$  is 2.5pF.

R can then be used to set the output impedance according to the following equation:

$$R = \left( \frac{1}{4 \cdot R_{OUT}} - \frac{1}{R_P} \right)^{-1}$$

where  $R_{OUT}$  is the desired output impedance and  $R_P$  is the parasitic equivalent parallel resistance of L1.

$C_2$  should first be set to 0 and C1 should be chosen as high as possible (not greater than 39pF), while maintaining an  $R_P$  of L1 that allows for the desired  $R_{OUT}$ . If the self-resonant frequencies of the selected C1 produce unsatisfactory linearity performance, their values may be reduced and compensated for by including C2 capacitor with a value chosen to maintain the desired  $F_{IF}$  frequency.

L2 and C3 serve dual purposes. L2 serves as an output bias choke, and C3 serves as a series DC block.

In addition, L2 and C3 may be chosen to form an impedance matching network if the input impedance of the IF filter is not equal to  $R_{OUT}$ . Otherwise, L2 is chosen to be large (suggested 120nH) and C3 is chosen to be large (suggested 22nF) if a DC path to ground is present in the IF filter, or omitted if the filter is DC-blocked.

## Differential IF Matching

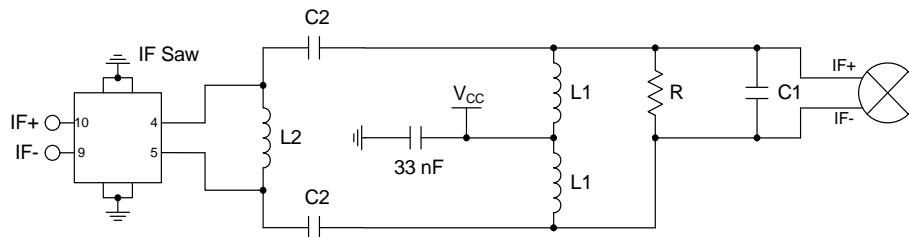

L1 and C1 are chosen to resonate at the desired IF frequency. C1 can be omitted and the value of L1 increased and utilized solely as a choke to provide  $V_{CC}$  to the open-collector outputs, but it is strongly recommended that at least some small-valued C1 (a few pF) be retained for better mixer linearity performance. R is normally selected to match the input impedance of the IF filter. However, mixer performance can be modified by selecting an R value that is different from the IF filter input impedance, and inserting a conjugate matching network between the Resistive Output Network and the IF filter.

C2 serve dual purposes. C2 serves as a series DC block when a DC path to ground is present in the IF filter. In addition, C2 may be chosen to improve the combine performance of the mixer and IF filter. L2 should choose to resonate with the internal capacitance of the SAW filter. Usually, SAW filter has some capacitance. Otherwise, L2 could be eliminated.

A practical approach to obtain the differential matching is to tune the mixer to the correct load point for gain, IIP3, and NF using the single-end current combiner method. Second, use the component values found in the single-end approach as starting point for the differential matching. The two-shunt capacitors in the single-end could be converted in a parallel capacitor and the parallel inductor in the single-end need to be converted in two-choke inductor. Third, set the DC block capacitors (C2) in the differential-end matching to a high value (100pF) and retune the resonate circuit (C1 and L1) and the resistor (R) for optimal performance. After optimal performance is achieved and if performance is not satisfactory, decrease the series capacitors until optimal performance is achieved.

## PCB Design Requirements

### PCB Surface Finish

The PCB surface finish used for RFMD's qualification process is electroless nickel, immersion gold. Typical thickness is 3µinch to 8µinch gold over 180µinch nickel.

### PCB Land Pattern Recommendation

PCB land patterns are based on IPC-SM-782 standards when possible. The pad pattern shown has been developed and tested for optimized assembly at RFMD; however, it may require some modifications to address company specific assembly processes. The PCB land pattern has been developed to accommodate lead and package tolerances.

### PCB Metal Land Pattern

