

Package: QFN, 32-Pin, 5mm x 5mm x 0.95mm



Features

- RF Frequency = 17.7GHz to 26.5GHz
- LO Frequency = 6.85GHz to 15.25GHz
- IF Frequency = DC to 4GHz
- Conversion Gain = 13dB
- Noise Figure = 2.5dB
- IIP3 = 6dBm
- Image Rejection = 15dB
- Low Cost 5mm x 5mm QFN Package

Applications

- Point-Point Radio
- Point-Multipoint Radio
- Satellite Communications
- Radar
- Electronic Warfare

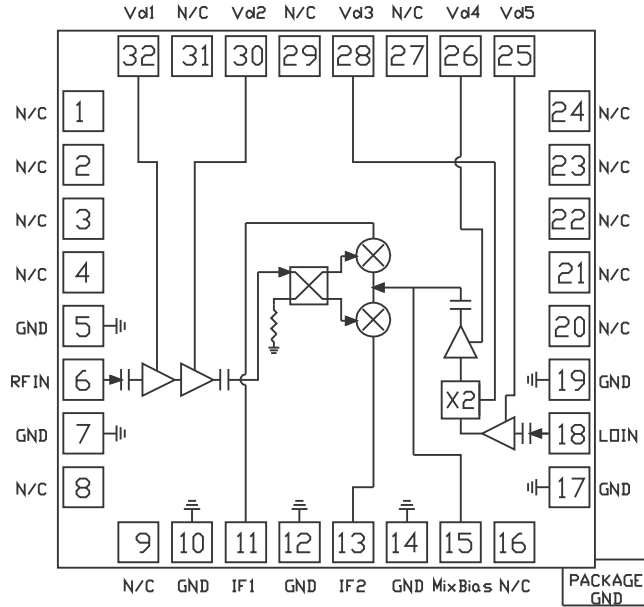

Functional Block Diagram

Product Description

The RFRX1701 is a 17.7GHz to 26.5GHz GaAs pHEMT downconverter, incorporating a low-noise amplifier, an integrated X2 LO frequency multiplier and buffer amplifier, and an image rejection mixer. The combination of high performance part and low cost packaging makes the RFRX1701 a cost effective solution, ideally suited to both current and next generation Point-to-Point Microwave Radio and Satellite Applications. RFRX1701 is packaged in a 5mm x 5mm QFN to simplify both system level board design and volume assembly.

Ordering Information

RFRX1701S2	2-piece sample bag
RFRX1701SB	5-piece bag
RFRX1701SQ	25-piece bag
RFRX1701SR	100 pieces
RFRX1701TR7	750 pieces on a 7" reel
RFRX1701PCBA-410	Evaluation Board

Optimum Technology Matching® Applied

- | | | | |
|--------------------------------------|--------------------------------------|--|------------------------------------|
| <input type="checkbox"/> GaAs HBT | <input type="checkbox"/> SiGe BiCMOS | <input checked="" type="checkbox"/> GaAs pHEMT | <input type="checkbox"/> GaN HEMT |
| <input type="checkbox"/> GaAs MESFET | <input type="checkbox"/> Si BiCMOS | <input type="checkbox"/> Si CMOS | <input type="checkbox"/> BiFET HBT |
| <input type="checkbox"/> InGaP HBT | <input type="checkbox"/> SiGe HBT | <input type="checkbox"/> Si BJT | |

RF MICRO DEVICES®, RFMD®, Optimum Technology Matching®, Enabling Wireless Connectivity™, PowerStar®, POLARIS™ TOTAL RADIO™ and UltimateBlue™ are trademarks of RFMD, LLC. BLUETOOTH is a trademark owned by Bluetooth SIG, Inc., U.S.A. and licensed for use by RFMD. All other trade names, trademarks and registered trademarks are the property of their respective owners. ©2012, RF Micro Devices, Inc.

Absolute Maximum Ratings

Parameter	Rating	Unit
LNA Drain Voltage (V_D)	6	V
LOA Drain Voltage (V_D)	6	V
RF Input Power	10	dBm
LO Input Power	15	dBm
T_{OPER}	-40 to +85	°C
T_{STOR}	-65 to +150	°C
ESD Human Body Model	Class 1A	



Caution! ESD sensitive device.

Exceeding any one or a combination of the Absolute Maximum Rating conditions may cause permanent damage to the device. Extended application of Absolute Maximum Rating conditions to the device may reduce device reliability. Specified typical performance or functional operation of the device under Absolute Maximum Rating conditions is not implied.

The information in this publication is believed to be accurate and reliable. However, no responsibility is assumed by RF Micro Devices, Inc. ("RFMD") for its use, nor for any infringement of patents, or other rights of third parties, resulting from its use. No license is granted by implication or otherwise under any patent or patent rights of RFMD. RFMD reserves the right to change component circuitry, recommended application circuitry and specifications at any time without prior notice.



RFMD Green: RoHS compliant per EU Directive 2002/95/EC, halogen free per IEC 61249-2-21, < 1000ppm each of antimony trioxide in polymeric materials and red phosphorus as a flame retardant, and <2% antimony in solder.

Parameter	Specification			Unit	Condition
	Min.	Typ.	Max.		
Overall					
RF Frequency	17.7		26.5	GHz	
LO Frequency	6.85		15.25	GHz	
IF Frequency	DC		4.0	GHz	
LO Input Drive		+5		dBm	
Conversion Gain		13		dB	
NF (17.7GHz to 19.7GHz)		2.5		dB	
NF (21.2GHz to 23.6GHz)		2.7		dB	
NF (24.5GHz to 26.5GHz)		2.9		dB	
IIP3		6		dBm	
Image Rejection		15		dB	
LO to RF Isolation		40		dB	
LO to IF Isolation		15		dB	
LO Return Loss		12		dB	
RF Return Loss		12		dB	
V_D		3 to 5		V	
I_D		350		mA	

NOTES: Measurements performed on part soldered on evaluation board with SMA connectors and IF ports connected to an external 90° Hybrid Combiner and LO Power of +5dBm and at 25 °C, unless otherwise stated.

IF = 2.5GHz, RF Power = -20dBm, IIP3 is measured with a 2-tone input of -23dBm power for each tone and $\Delta f = 10\text{MHz}$, $V_{d1} = 3\text{V}$, $V_{d2} = 4\text{V}$, V_{d3} through $V_{d5} = 5\text{V}$, MixerBias = 0V

Pin Names and Description

Pin	Function	Description
1	N/C	Not Connected
2	N/C	Not Connected
3	N/C	Not Connected
4	N/C	Not Connected
5	GND	GND
6	RF	RF Input, AC coupled and matched to 50Ω
7	GND	GND
8	N/C	Not Connected
9	N/C	Not Connected
10	GND	GND
11	IF1	IF1 Output
12	GND	GND
13	IF2	IF2 Output
14	GND	GND
15	Mixer Bias	Mixer Bias = 0V
16	N/C	Not Connected
17	GND	GND
18	LO	LO Input, AC coupled and matched to 50Ω
19	GND	GND
20	N/C	Not Connected
21	N/C	Not Connected
22	N/C	Not Connected
23	N/C	Not Connected
24	N/C	Not Connected
25	Vd5	Vd5 (LOA bias) = 5V
26	Vd4	Vd4 (LOA bias) = 5V
27	N/C	Not Connected
28	Vd3	Vd3 (LOA bias) = 5V
29	N/C	Not Connected
30	Vd2	LNA drain bias2 = 4V
31	N/C	Not Connected
32	Vd1	LNA drain bias1 = 3V

Pin Out

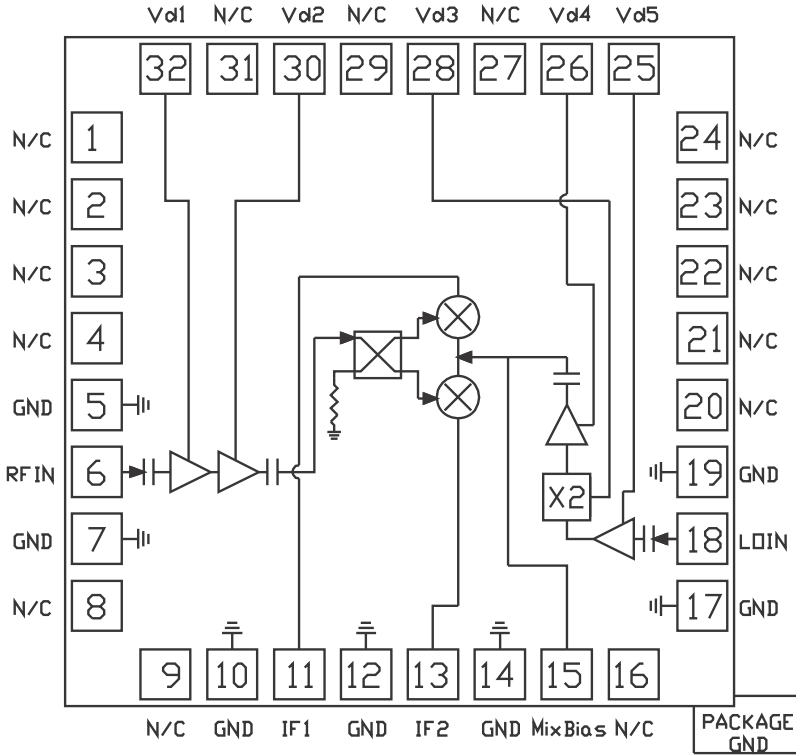

Typical Electrical Performance

Measurements performed on part soldered on evaluation board with SMA connectors and IF ports connected to an external 90° Hybrid Combiner and LO Power of +5dBm, unless otherwise stated.

IF = 2.5GHz, RF Power = -20dBm, IIP3 is measured with a 2-tone input of -23dBm power for each tone and $\Delta f = 10\text{MHz}$, Vd1 = 3V, Vd2 = 4V, Vd3 through Vd5 = 5V, MixerBias = 0V.

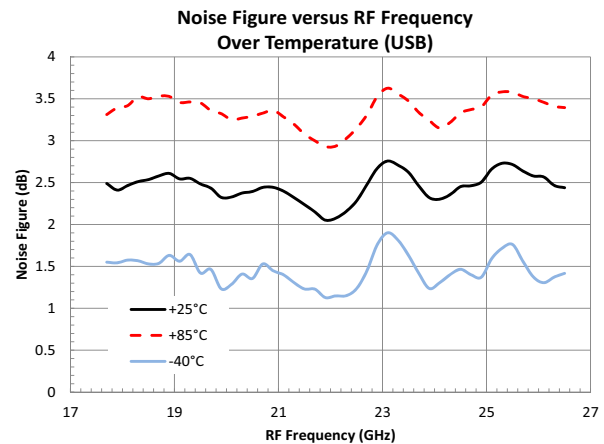
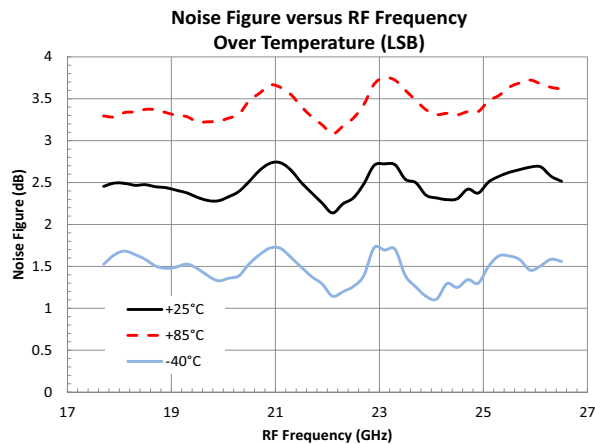
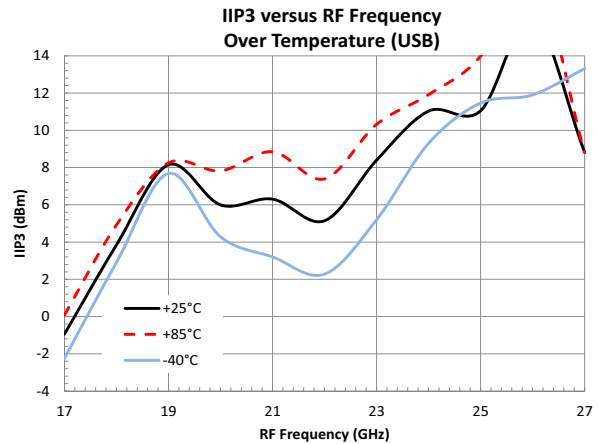
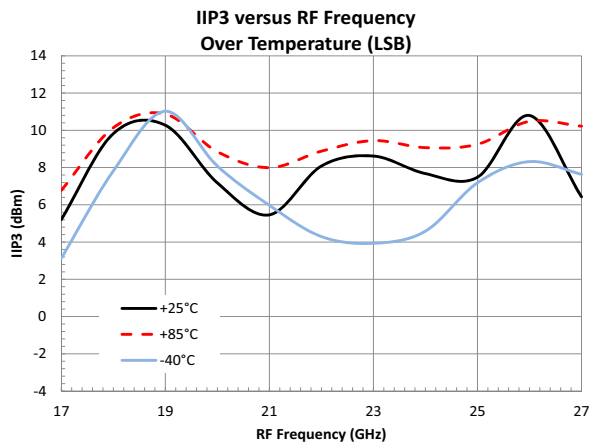
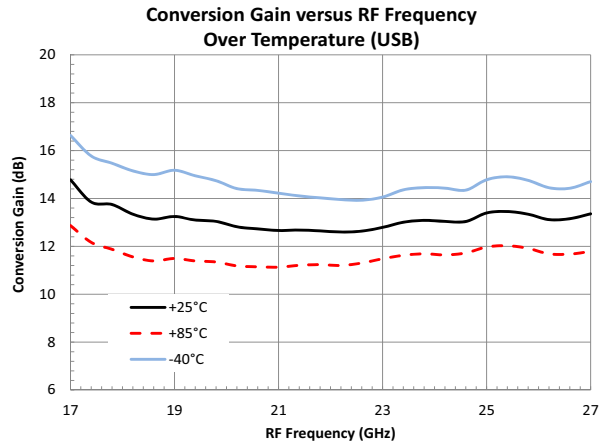
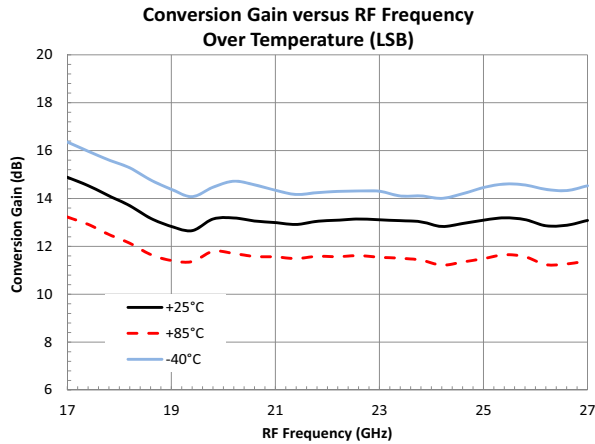

Typical Electrical Performance (continued)

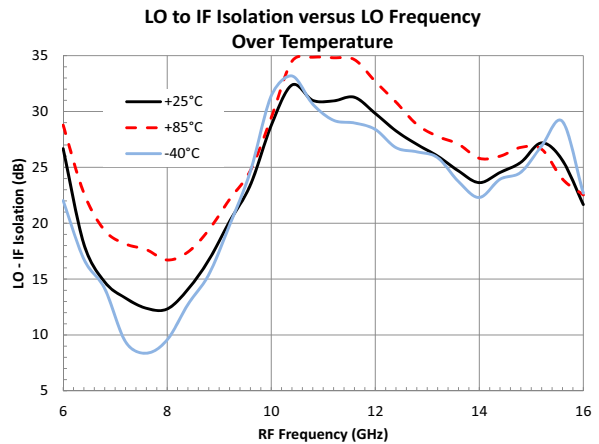
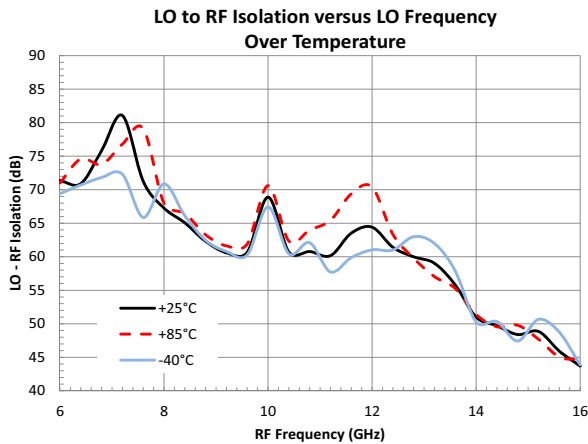
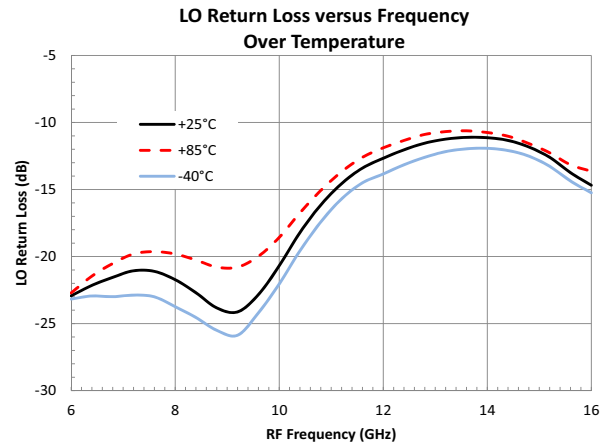
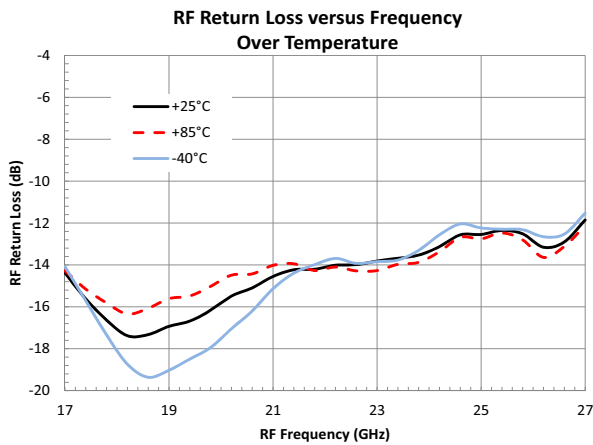
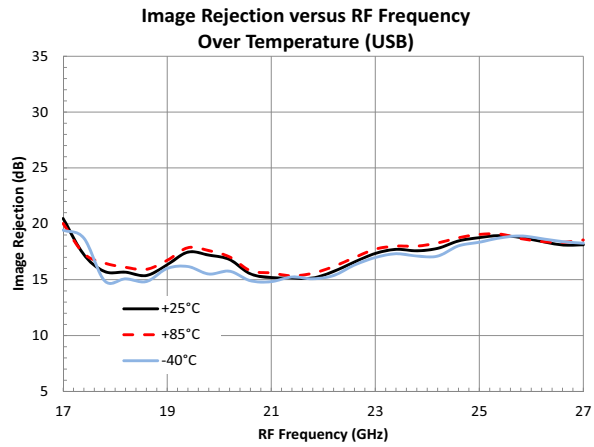
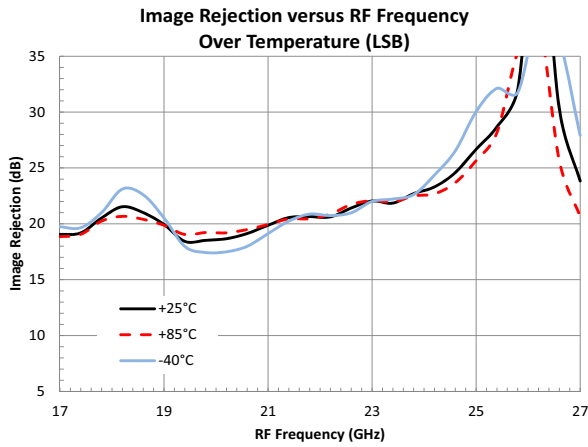

Package Outline Drawing
(QFN, 32-Pin, 5mm x 5mm x 0.95mm)

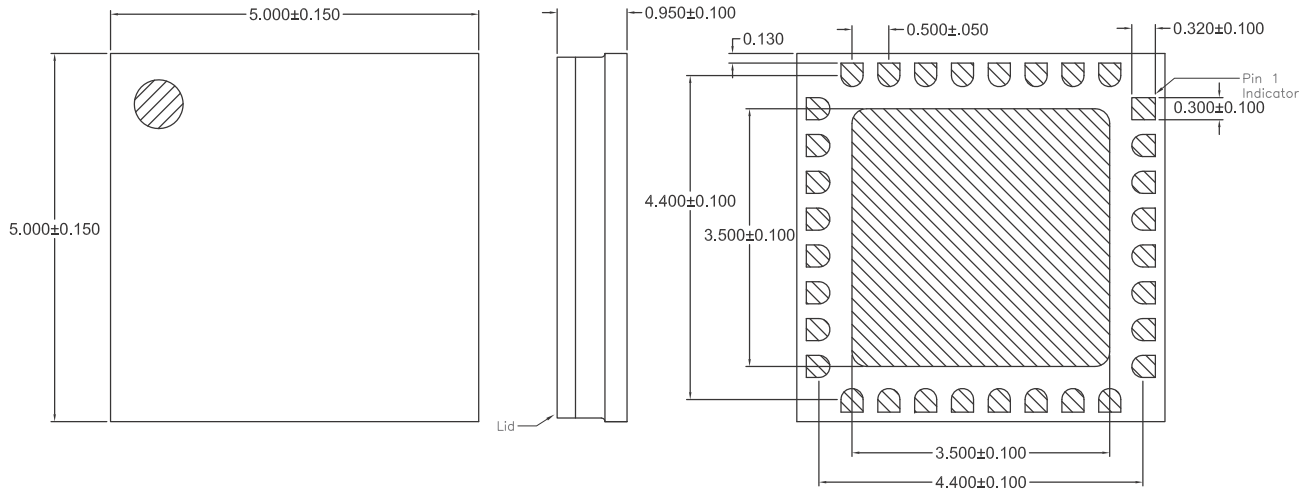

Application Circuit Block Diagram

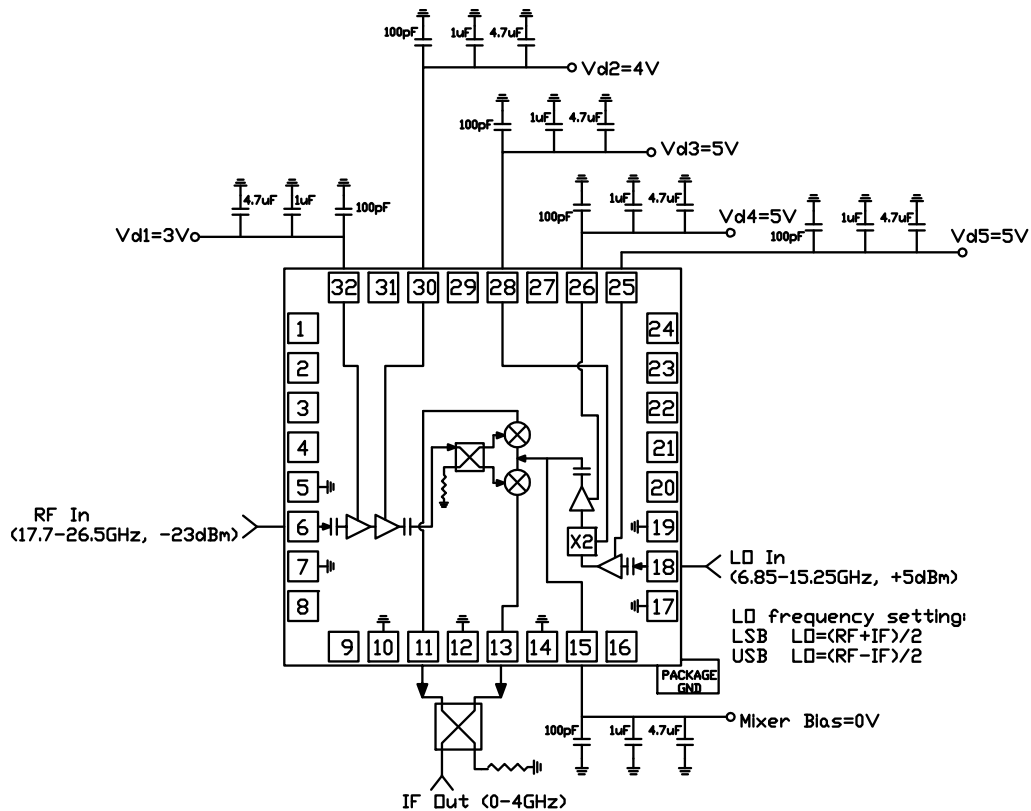

Evaluation Board

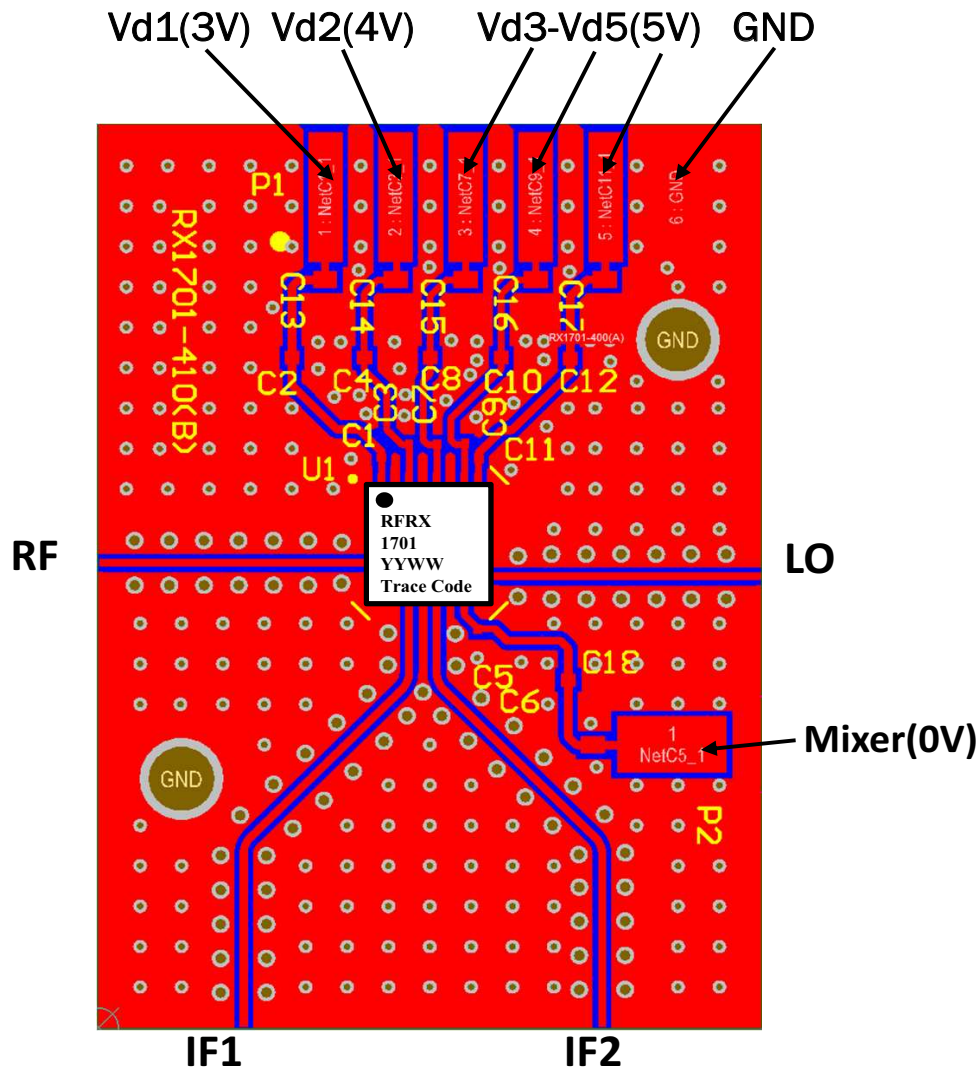

$C1=C3=C5=C7=C9=C11=100\text{pF}$
 $C2=C4=C6=C8=C10=C12=1\mu\text{F}$
 $C13=C14=C15=C16=C17=C18=4.7\mu\text{F}$

Test Condition

LO Power	+5dBm
RF Power	-20dBm
Vd1	3.0V
Vd2	4.0V
Vd3, Vd4, Vd5	5.0V
Mixer Bias	0V