



Package Style: QFN, 16-pin, 3mmx3mmx0.5mm



Features

- Integrated 2.4GHz to 2.5GHz b/g/n Amplifier, LNA, SP3T Switch, and Power Detector Coupler
- Single Supply Voltage 3.0V to 4.8V
- $P_{OUT} = 19.5\text{dBm}$, 11g, OFDM at <math><3.3\%</math> EVM, 22dBm 11b Meeting 11b Spectral Mask
- Low Height Package, Suited for SiP and CoB Designs

Applications

- Cellular handsets
- Mobile devices
- Tablets
- Consumer electronics
- Gaming
- Netbooks/Notebooks
- TV/monitors/video
- SmartEnergy

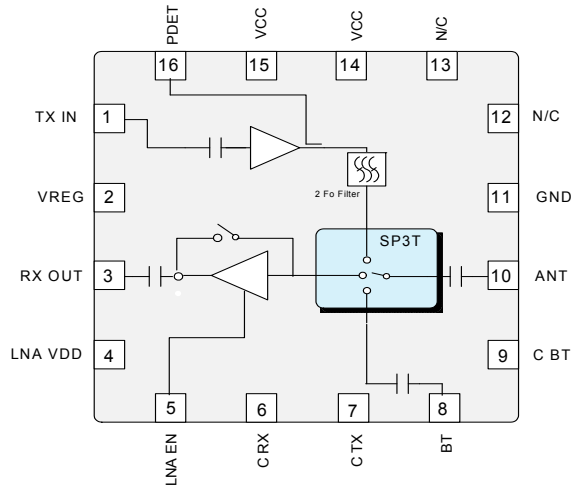

Functional Block Diagram

Product Description

The RF5565 provides a complete integrated solution in a single Front End Module (FEM) for WiFi 802.11b/g/n and Bluetooth® systems. The ultra small form factor and integrated matching greatly reduces the number of external components and layout area in the customer application. This simplifies the total Front End solution by reducing the bill of materials, system footprint, and manufacturability cost. The RF5565 integrates a 2.4GHz Power Amplifier (PA), Low Noise Amplifier (LNA) with bypass mode, power detector coupler for improved accuracy, and some filtering for harmonic rejection. The device is provided in a 3mmx3mmx0.5mm, 16-pin package. This module meets or exceeds the RF Front End needs of IEEE 802.11b/g/n WiFi RF systems.

Ordering Information

RF5565SQ	Standard 25 pieces sample bag
RF5565SR	Standard 100 pieces reel
RF5565TR7	Standard 2500 pieces reel
RF5565PCK-410	Fully assembled evaluation board with 5-piece bag

Optimum Technology Matching® Applied

- | | | | |
|---|--------------------------------------|--|-----------------------------------|
| <input type="checkbox"/> GaAs HBT | <input type="checkbox"/> SiGe BiCMOS | <input checked="" type="checkbox"/> GaAs pHEMT | <input type="checkbox"/> GaN HEMT |
| <input type="checkbox"/> GaAs MESFET | <input type="checkbox"/> Si BiCMOS | <input type="checkbox"/> Si CMOS | <input type="checkbox"/> RF MEMS |
| <input checked="" type="checkbox"/> InGaP HBT | <input type="checkbox"/> SiGe HBT | <input type="checkbox"/> Si BJT | <input type="checkbox"/> LDMOS |

Absolute Maximum Ratings

Parameter	Rating	Unit
DC Supply Voltage (Continuous with No Damage)	5.4	V
DC Supply Current	500	mA
Case Temperature (Full Spec. Compliant)	-10 to +70	°C
Extreme Operating Case Temperature (Reduced Performance)	-40 to -10 +70 to +85	°C
Storage Temperature	-40 to +150	°C
Maximum TX Input Power into 50Ω Load for 11b/g/n (No Damage)	0	dBm
Maximum RX Input Power (No Damage)	0	dBm
Moisture Sensitivity	MSL2	



Caution! ESD sensitive device.

Exceeding any one or a combination of the Absolute Maximum Rating conditions may cause permanent damage to the device. Extended application of Absolute Maximum Rating conditions to the device may reduce device reliability. Specified typical performance or functional operation of the device under Absolute Maximum Rating conditions is not implied.

RoHS status based on EUDirective2002/95/EC (at time of this document revision).

The information in this publication is believed to be accurate and reliable. However, no responsibility is assumed by RF Micro Devices, Inc. ("RFMD") for its use, nor for any infringement of patents, or other rights of third parties, resulting from its use. No license is granted by implication or otherwise under any patent or patent rights of RFMD. RFMD reserves the right to change component circuitry, recommended application circuitry and specifications at any time without prior notice.

Parameter	Specification			Unit	Condition	
	Min.	Typ.	Max.			
2.4 GHz Transmit Parameters						
Compliance					IEEE802.11b, IEEE802.11g, FCC CFG 15.247, .205, .209, EN, and JDEC	
Nominal Conditions					V _{CC} =3.3V to 4.2V; V _{REG} =3V to 3.2V; Switch Control voltage=3V to 3.6V; Temp=-10°C to +70°C; Unless noted otherwise.	
Frequency	2.4		2.5	GHz		
Power Supply	3.0	3.3	4.8	V	Voltage Supply Operating Range	
V _{REG} Voltage						
	ON	3.0	3.1	3.2	V	PA in "ON" state
	OFF		0.00	0.20	V	PA in "OFF" state
Output Power						
	11g	18	18.5		dBm	54Mbps, OFDM 54Mbps, V _{CC} ≥3.0V
		18.5	19.5		dBm	54Mbps, OFDM 54Mbps, V _{CC} ≥3.3V
	11b	20	22		dBm	11Mbps, CCK, V _{CC} ≥3.0V
EVM			3.3	4.0	%	P _{OUT(g)} =Rated Output Power, 54Mbps OFDM, 50Ω, see note 1
Adjacent Channel Power						P _{OUT(b)} =20dBm 11Mbps CCK, note 2
	ACP1		-36	-33	dBc	Nominal conditions, meeting 11b spectral mask requirements
	ACP2		-56	-51	dBc	
Gain		26	30	34.5	dB	
Gain Variation Slope						At rated power and a given supply voltage
	Range	3.0		4.2	V	
	V _{CC} (Average)			0.5	dB/V	
	V _{CC} (Instantaneous)			1	dB/V	
	Frequency	-0.5		+0.5	dB	2.4GHz to 2.5GHz

Parameter	Specification			Unit	Condition
	Min.	Typ.	Max.		
2.4GHz Transmit Parameters, cont.					
Typical Input Power					
	11g	-9		dBm	
	11b	-5		dBm	
Power Detect					
Power Range	0		23	dBm	
Voltage Range	0.1		1.5	V	
Resistance		10		k Ω	
Capacitance			10	pF	
Sensitivity					
	$0 < P_{OUT} < 6$ dBm	3		mV/dB	
	$6 < P_{OUT} < 23$ dBm	8	350	mV/dB	
Current Consumption					$V_{CC}=3.3V, V_{REG}=3.1V, T=25^{\circ}C$
	I_{CC}	170	200	mA	RF $P_{OUT}=18.5$ dBm, 11g, 50 Ω
		220	250	mA	RF $P_{OUT}=20$ dBm, 11b, 50 Ω
Quiescent Current		90		mA	RF = "OFF"
	I_{REG}		3	mA	$V_{REG} > 3.0V$
V_{CC} Leakage Current		2	10	μA	$V_{CC}=4.8V, V_{REG}=C_{BT}=C_{RX}=C_{BWRX} \leq 0.2V$
Input Port Impedance		50		Ω	
Input Port Return Loss	10	15		dB	
Ruggedness					No Damage Conditions: max operating voltage, max input power, max temperature
Output VSWR			10:1		
Input Power			-5	dBm	
Stability					PA must be stable (no spurs above -43dBm) from 0 to 20dBm, All phase angles, no spurious or oscillations
Output VSWR	6:1				
Out-of-Band Emissions 2310MHz to 2390MHz and 2483.5MHz to 2500MHz			-41.25	dBm/MHz	$P_{OUT}=16.5$ dBm, 54Mbps OFDM Modulation, 64QAM, RBW=1MHz, VBW=100kHz, $V_{CC}=3.3V, V_{REG}=3.1V$
			-41.25	dBm/MHz	$P_{OUT}=20.5$ dBm, 11Mbps CCK Modulation, RBW=1MHz, VBW=100kHz, $V_{CC}=3.3V, V_{REG}=3.1V$
Thermal Resistance		20		$^{\circ}C/W$	$V_{CC}=4.8, V_{REG}=3.2V, P_{OUT}=20$ dBm, $T_{REF}=85^{\circ}C$
Harmonics					11b modulation, 1Mbps, BW=1MHz, up to 3:1 load
	Second		-23	dBm	4.80GHz to 5.00GHz
	Third		-20	dBm	7.20GHz to 7.50GHz
Turn-on/off Time		0.5	1.0	μS	Output stable to within 90% of final gain, Note 1

Parameter	Specification			Unit	Condition
	Min.	Typ.	Max.		
2.4GHz Receive Parameters					
Compliance					IEEE802.11b, IEEE802.11g, FCC CFG 15.247, .205, .209, EN, and JDEC
Frequency	2.4		2.5	GHz	
LNA Voltage Supply	3.0	3.3	4.8	V	LNA V _{DD} tied to V _{BATT} at all times
LNA Current	5	12	20	mA	LNA in "ON" state
	0		5	μA	LNA in "OFF" state (C_RX=low, LNA V _{DD} =ON)
LNA Input P1dB	-9	-5		dBm	
Gain					
WiFi RX Gain	11	14	16	dB	WiFi RX mode
Bypass Mode	-4			dB	WiFi Bypass Mode
Noise Figure					V _{CC} ≥ 3.3V, including switch
WiFi RX		2.2	3.5	dB	
Bypass Mode		2.6	4	dB	
Passband Ripple	-0.5		+0.5	dB	WiFi RX Mode
	-0.5		+0.5	dB	WiFi Bypass Mode
WiFi RX Output Return Loss	9.6			dB	
WiFi RX Input Return Loss	5	7		dB	Measured at antenna port
WiFi RX Port Impedance		50		Ω	No external matching
Bluetooth Parameters					
Frequency	2.4		2.5	GHz	
Insertion Loss					
BT TX/RX		0.9	1.2	dB	Bluetooth mode (measured ANT to BT port)
Passband Ripple	-0.2		+0.2	dB	Bluetooth mode
Bluetooth Output Return Loss	9.6			dB	Switch in Bluetooth Mode
Input P1dB		28		dBm	
Other Requirements					
Antenna Port Impedance					
Output		50		Ω	
Return Loss	5	7		dB	
Isolation					
Antenna to Receive	20			dB	In BT Mode (measured from ANT to RX port)
Antenna to Bluetooth®	20			dB	In TX Mode (measured from ANT to BT port)
Antenna to Receive	20			dB	In TX Mode (measured from ANT to RX port)
Switch Control Voltage					C_RX, C_BT, and C_TX control lines
Low		0	0.2	V	Switch is in the low state (L)
High	3.0		3.6	V	Switch is in the high state (H)
Switch Control Current		2	10	μA	Per control line
LNA_EN Control Current		60	100	μA	Over V _{CC} , Frequency and Temperature.
Switch Control Speed			10	nsec	
Switch P1dB		28		dBm	

Parameter	Specification			Unit	Condition
	Min.	Typ.	Max.		
Other Requirements, cont.					
ESD					
Human Body Model	500			V	EIA/JESD22-114A RF pins
	1000			V	EIA/JESD22-114A DC pins
Charge Device Model	500			V	JESD22-C101C all pins

Note 1: The PA module must operate with gated bias voltage input at 1% to 99% duty cycle.

Note 2: The output power for channels 1 and 11 may be reduced to meet FCC restricted band requirements.

Switch Control Logic

Mode	C_TX	C_RX	C_BT	VREG	LNA_EN
Transmit	H	L	L	H	L
Receive	L	H	L	L	H
Bypass	L	H	L	L	L
Bluetooth	L	L	H	L	L
Standby	L	L	L	L	L
Logic Voltage Levels	H	3.0V to 3.6V			
	L	<0.2V			

Pin	Function	Description
1	TX_IN	RF input for the 802.11b/g PA. Input is matched to 50Ω and DC block is provided.
2	VREG	Regulated voltage for the bias control circuit. An external bypass capacitor may be needed on the V _{REG} line for decoupling purposes.
3	RX OUT	Receive port for 802.11b/g band. Internally matched to 50Ω. DC block provided.
4	LNA VDD	Voltage supply for the LNA.
5	LNA_EN	Control voltage for the LNA. When this pin is set to a LOW logic state, the bypass mode is enabled.
6	C RX	Receive switch control pin. See switch truth table for proper level.
7	C_TX	Switch control voltage for the transmit branch. See logic control table for proper settings.
8	BT	RF bidirectional port for <i>Bluetooth</i> [®] . Input is matched to 50Ω and DC block is provided.
9	C_BT	<i>Bluetooth</i> [®] switch control pin. See truth table for proper level.
10	ANT	Port matched to 50Ω and is DC blocked internally.
11	GND	Ground.
12	N/C	No connect.
13	N/C	No connect.
14	VCC	Supply voltage for the PA.
15	VCC	Supply voltage for the PA.
16	PDETECT	Power detector voltage for TX section. PDET voltage varies with output power. May need external decoupling capacitor for noise bypassing. May need external circuitry to bring output voltage to desired level.

Pin Out

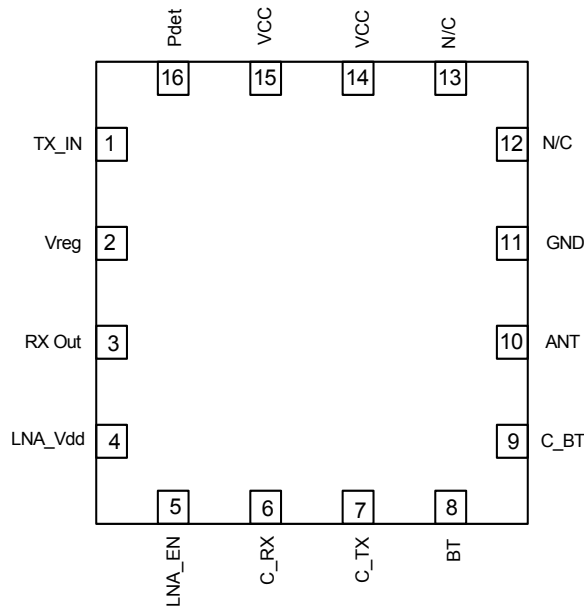

Package Drawing

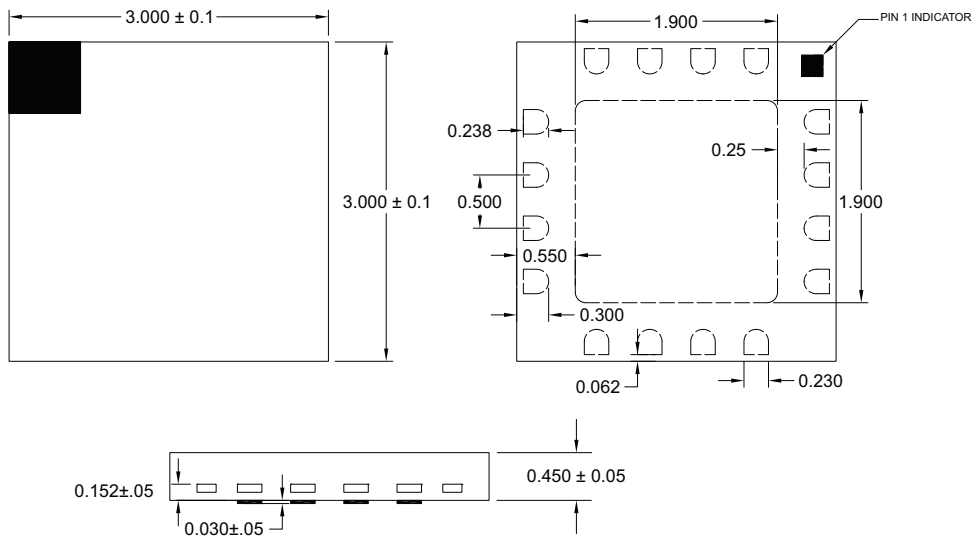

NOTES:

- 1 Shaded Area is Pin 1 Indicator

RF5565 PCB Footprint and Stencil Recommendations

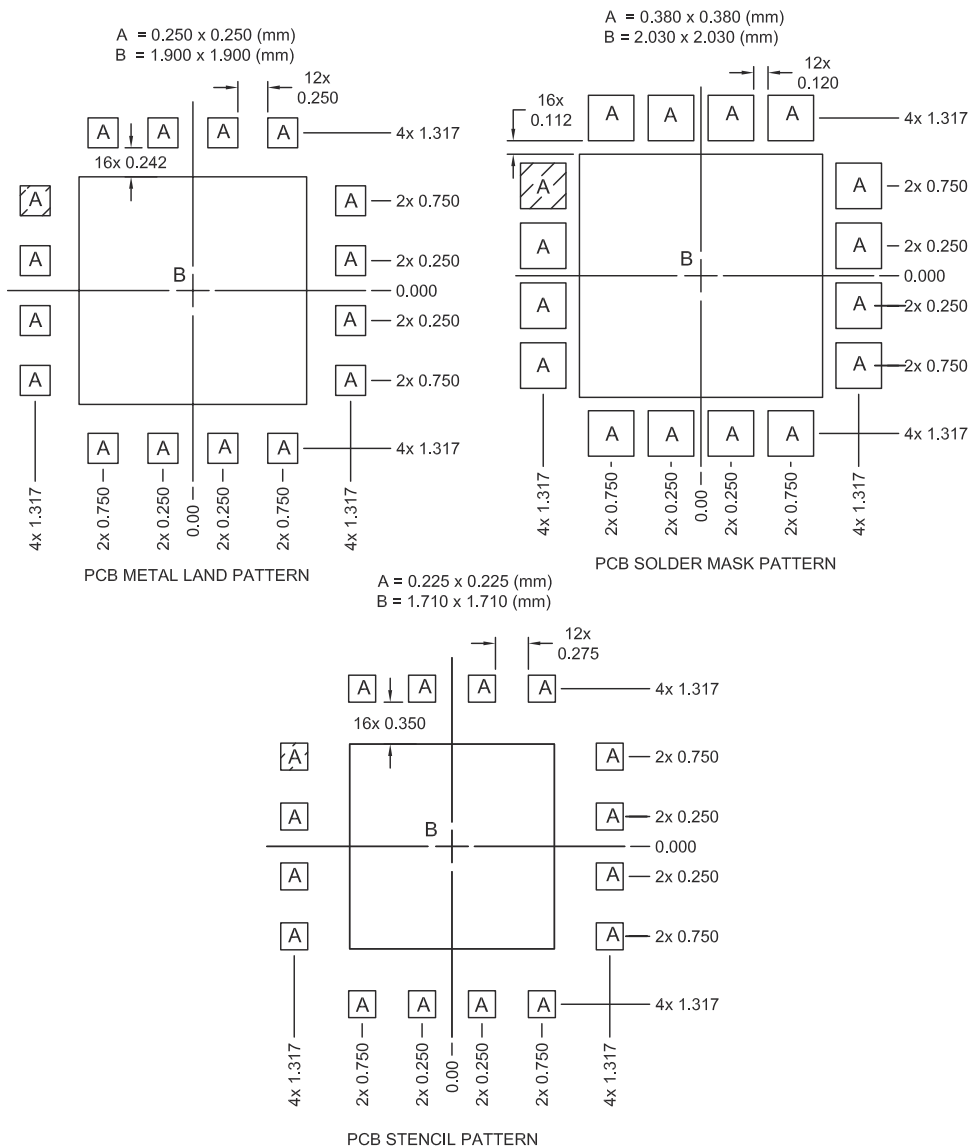

Shaded are represents Pin 1 location.

Thermal vias for center slug "B" should be incorporated into the PCB design. The number and size of thermal vias will depend on the application, the power dissipation, and the electrical requirements. Example of the number and size of vias can be found on the RFMD evaluation board layout.

Evaluation Board Schematic

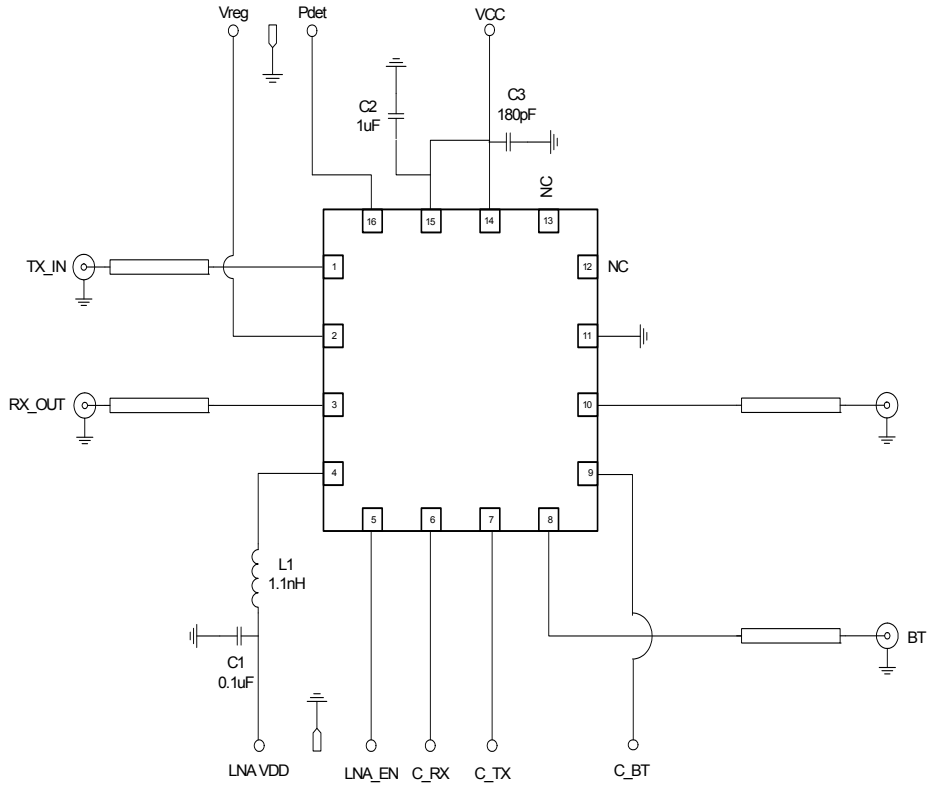

Theory of Operation

The RF5565 Front End Module (FEM) is designed for WiFi applications in the 2.5GHz ISM band. It can be applied in many portable applications such as handsets, Personal Media Players, and portable battery power equipment. This highly integrated module can be connected directly to the battery without additional voltage regulators.

WiFi TRANSMIT MODE

The RF5565 requires a single positive supply (V_{CC}), a positive supply for switch controls, and a regulated supply for the V_{REG} to maintain nominal bias current. The RF5565 transmit path has a typical gain of 30dB from 2.4GHz to 2.5GHz, and delivers 20dBm typical output power under 54Mbps OFDM modulation and 22dBm under 1Mbps 11b modulation. The RF5565 contains basic filter components to produce a bandpass response for the transmit path. Due to space constraints inside the module, filtering is limited to a few resonant poles and additional filters may be required depending upon the end-user's application. While in transmit mode, the active components are the Power Amplifier (PA) and the TX branch of the SP3T switch. Refer to the logic control table for proper settings.

TX Biasing Instructions

- Connect the TX input to a signal generator and a spectrum analyzer at the Antenna output.
- Set V_{CC} to 3.3V with V_{REG} set to 0V.
- Turn V_{REG} ON and set voltage to 3.1V. V_{REG} controls the current drawn by the PA and it should quickly reach a quiescent current of approximately $90\text{mA} \pm 20\text{mA}$. Care must be exercised not to exceed 3.5V on the V_{REG} pin or the part may be damaged.
- Next set C_{TX} high. This pin controls the transmit branch of the SP3T.
- The SP3T controls for the off branches (C_{RX} and C_{BT}) must be set to a logic "low" (0.2V max) or grounded. In the event that one of these branches is left floating or in a logic "high" the performance of the PA will degrade significantly. Likewise, unused RF Ports must be terminated in 50Ω to simulate actual system conditions and prevent RF signals from coupling back to the PA.
- Turn RF ON.

WiFi RECEIVE MODE

Within the frequency band of operation 2.4GHz to 2.5GHz, the RF5565 WiFi receive path has a typical gain of 14dB and a NF of 2.2dB with about 12mA of current. In RX mode, only the RX branch of the SP3T and the LNA are active. Refer to the logic control table for proper settings.

RX Biasing Instructions

- Connect the RX input (ANT/pin-10) to a signal generator and a spectrum analyzer at the RX output. A VNA may be used as well.
- Turn LNA voltage supply ON and set the voltage to 3.3V.
- Set C_{RX} and LNA_{EN} high. This turns the LNA and the receive branch of the SP3T ON.
- The SP3T controls for the off branches (C_{TX} and C_{BT}) must be set to a logic "low" (0.2V max) or grounded. In the event that one of these branches is left floating or in a logic "high" the performance will degrade. It is recommended to terminate unused RF Ports in 50Ω .
- Turn RF ON.

Bypass Mode for WiFi Receive Operation

- Connect the RF input (ANT/pin-10) to a signal generator and a spectrum analyzer at the RX output. A multiport VNA may be used as well.
- Set LNA_EN low. By applying a voltage $<0.2V$ to this pin it enables the bypass switch of the LNA.
- Set C_RX high. This turns the receive branch of the SP3T ON.
- The SP3T controls for the off branches (C_TX and C_BT) must be set to a logic “low” (0.2V max) or grounded. In the event that one of these branches is left floating or in a logic “high” the performance will degrade. It is recommended to terminate unused RF Ports in 50Ω .
- Turn RF ON.

BLUETOOTH® MODE

The RF765 *Bluetooth*® only mode is implemented through the SP3T switch by setting C_BT “high.” Typical insertion loss is about 1dB.

Bluetooth® Biasing Instructions

- Connect the RF input (ANT/pin-10) to a signal generator and a spectrum analyzer at the BT (pin-8) RF port. A VNA may be used in place of the Sig Gen and SA.
- Set C_BT “high.” This turns the *Bluetooth*® branch of the SP3T switch ON.
- The SP3T controls for the off branches (C_TX and C_RX) must be set to a logic “low” (0.2V max) or grounded. Do not leave floating.
- Terminate unused RF Ports in 50Ω .
- Turn RF ON.

APPLICATION CIRCUIT AND LAYOUT RECOMMENDATIONS

The RF5565 integrates the matching networks and DC blocking capacitors for all RF ports. This greatly reduces the number of external components and layout area needed to implement this FEM. Typically only a total of four external components are required to achieve nominal performance. However, depending on board layout and the many noise signals that could potentially couple to the RF5565, additional bypassing capacitors may be required to properly filter out unwanted signals that might degrade performance.

The LNA bias components consist of an inductor and a decoupling capacitor. The inductor value is critical to optimize NF and return loss at the RX output. For best performance and trade off between critical parameters such as NF, Gain, and IP3, the total inductance including board trace should be approximately 1.2nH. The last components needed in the application circuit are low frequency bypass capacitors on the VCC line. In general, it is good RF practice to have proper decoupling of supply lines to filter noise out. Occasionally, depending on the level of coupling or parasitics of the board, a high frequency bypass capacitor must be added as well.

In order to optimize performance for both the Transmit and Receive paths, best known RF practices for PCB layout must be followed. All RF traces must be 50Ω . Adequate grounding along the RF traces and on the FEM ground slug must be exercised. This will minimize coupling and provide good thermal dissipation when the PA is operating at high power. For reference, RFMD evaluation board gerbers are available upon request.

RF5565 WiFi Transmit Performance Plots

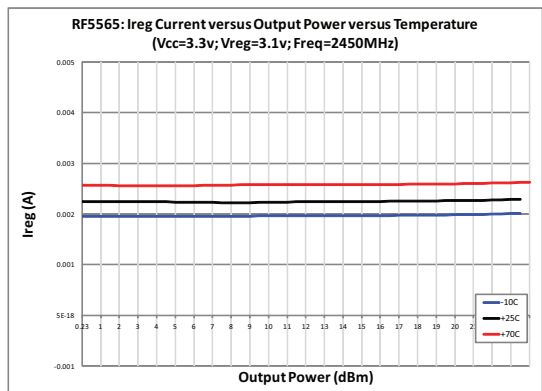
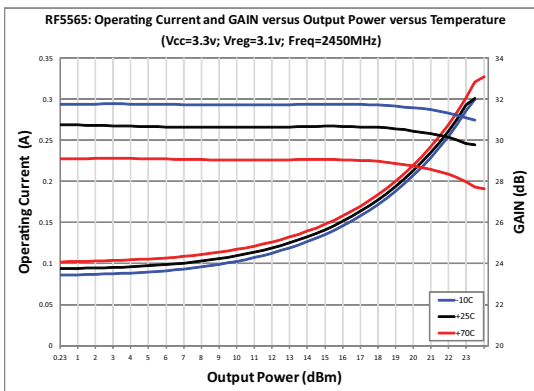
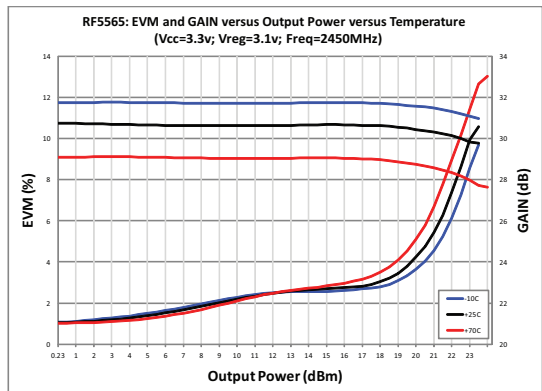
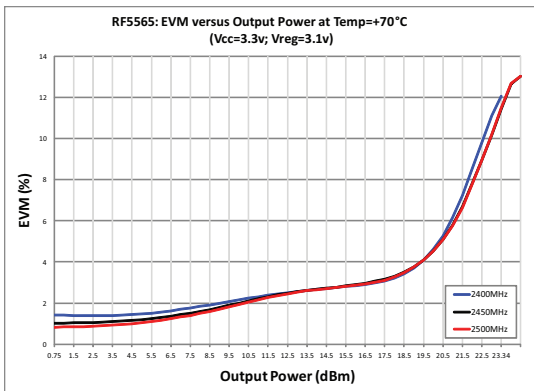
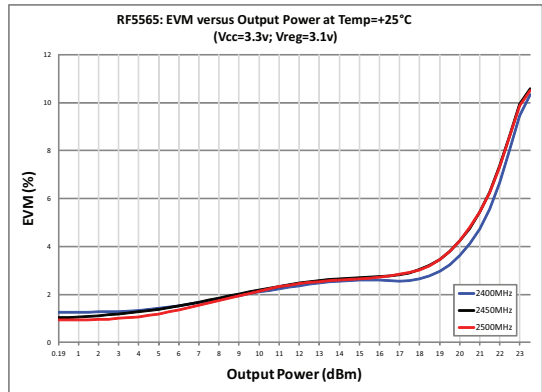
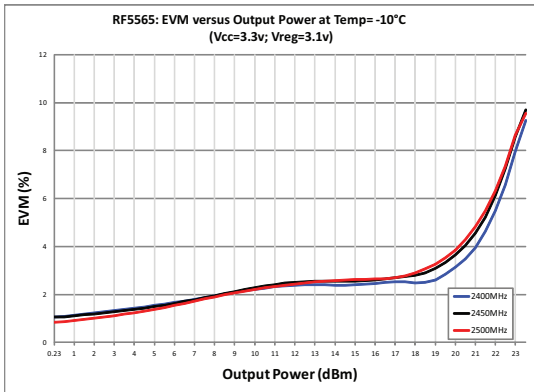

RF5565 WiFi Transmit Performance Plots (continued)

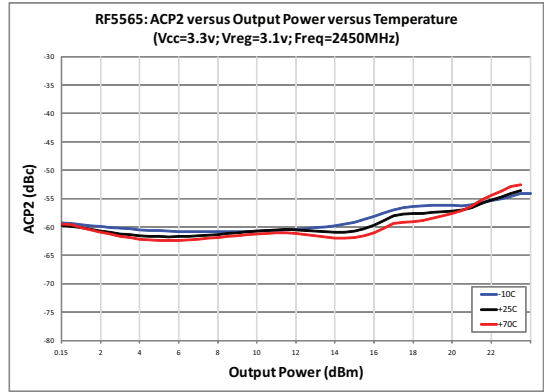
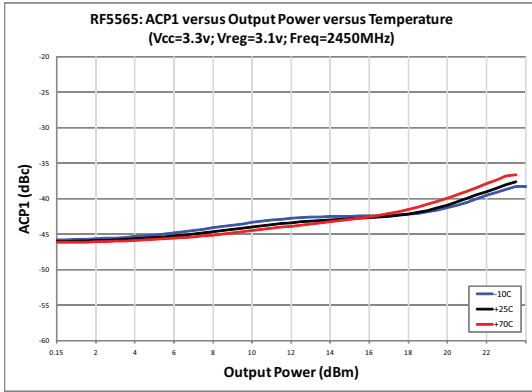

RF5565 WiFi Receive and BT Performance Plots

