



**Features**

- Small Size
- High Performance FEM
- Excellent Linearity
- Input and Output Matched to 50Ω
- Pout = 17.5dBm, 11a, OFDM at 2.5% EVM
- Integrated 5GHz PA, SP2T, Switch, LNA, and PDET
- Low Height Package, Suited for SiP and CoB Designs

**Applications**

- Cellular Handsets
- Mobile Devices
- Tablets
- Consumer Electronics
- Gaming
- Netbooks/Notebooks
- TV/Monitors/Video

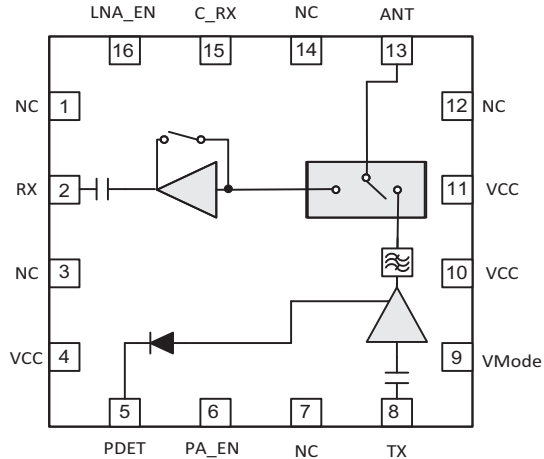

Functional Block Diagram

**Product Description**

The RFFM8502 provides a complete integrated solution in a single front end module (FEM) for WiFi 802.11a/n systems. The ultra-small form factor and integrated matching minimizes the layout area in the customer's application and greatly reduces the number of external components. This simplifies the total front end solution by reducing the bill of materials, system footprint, and manufacturability cost. The RFFM8502 integrates a power amplifier (PA), single pole double throw switch (SP2T), LNA with bypass, and a power detector coupler for improved accuracy. The device is provided in a 2.5mm x 2.5mm x 0.45mm, 16-pin QFN package. This module meets or exceeds the RF front end needs of IEEE 802.11a/n WiFi RF systems.

**Ordering Information**

RFFM8502SB	Standard 5-piece sample bag
RFFM8502	Standard 25-piece sample bag
RFFM8502SR	Standard 100-piece reel
RFFM8502TR7	Standard 2500-piece reel
RFFM8502PCK-410	Fully assembled evaluation board with 5-piece bag

**Optimum Technology Matching® Applied**

- |   |                                      |  |                                   |
|---|--------------------------------------|--|-----------------------------------|
| <input type="checkbox"/> GaAs HBT             | <input type="checkbox"/> SiGe BiCMOS | <input checked="" type="checkbox"/> GaAs pHEMT | <input type="checkbox"/> GaN HEMT |
| <input type="checkbox"/> GaAs MESFET          | <input type="checkbox"/> Si BiCMOS   | <input type="checkbox"/> Si CMOS               | <input type="checkbox"/> RF MEMS  |
| <input checked="" type="checkbox"/> InGaP HBT | <input type="checkbox"/> SiGe HBT    | <input type="checkbox"/> Si BJT                | <input type="checkbox"/> LDMOS    |

RF MICRO DEVICES®, RFMD®, Optimum Technology Matching®, Enabling Wireless Connectivity™, PowerStar®, POLARIS™ TOTAL RADIO™ and UltimateBlue™ are trademarks of RFMD, LLC. BLUETOOTH is a trademark owned by Bluetooth SIG, Inc., U.S.A. and licensed for use by RFMD. All other trade names, trademarks and registered trademarks are the property of their respective owners. ©2012, RF Micro Devices, Inc.

**Please contact  
RFMD Technical Support  
at (336) 678-5570  
for more information.**