



**Features**

- Single-Module Radio Front-End
- Single Supply Voltage 3.0V to 3.6V
- Integrated 2.5GHz & 5GHz PA's, Diplexers, Filters & Switches for TX & RX
- P<sub>OUT</sub>=18dBm, 11g, OFDM a 4% Typ EVM, P<sub>OUT</sub>=16dBm, 11a, OFDM @ 4% Typ EVM

**Applications**

- IEEE802.11a/b/g/n WiFi Applications
- Single-Chip RF Front-End Module
- 2.5GHz and 5GHz ISM Bands Applications
- WiFi Systems
- Portable Battery-Powered Equipment

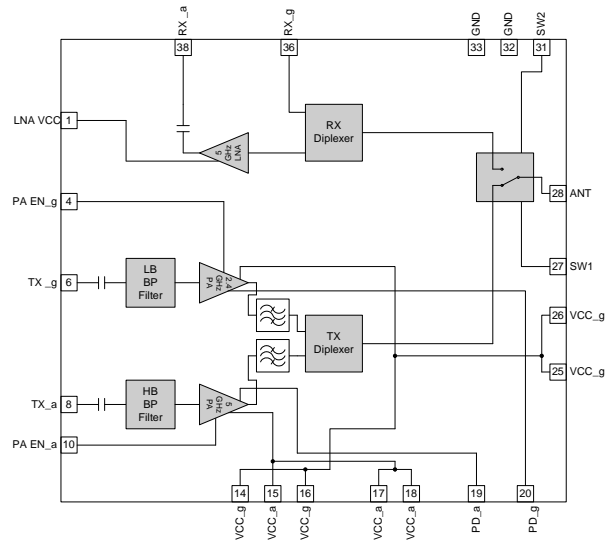

Functional Block Diagram

**Product Description**

The RF5388 is a single-chip dual-band integrated front-end module (FEM) for high-performance WiFi applications in the 2.5GHz and 5GHz ISM bands. The RF5388 addresses the need for aggressive size reduction for a typical 802.11a/b/g RF front-end design and greatly reduces the number of components outside of the core chipset thus minimizing the footprint and assembly cost of the overall 802.11a/b/g/n solution. The RF5388 contains integrated PA's for 2.5GHz and 5GHz, diplexers, TX/RX switch, LNA for the 5.0GHz receive band, matching components, some bypass capacitors, built-in power detector for both bands, and filters for transmit and receive paths. The RF5388 is packaged in a 40-pin, 6mmx6mmx0.9mm QFN package with backside ground. Greatly minimizes next level board space and allows for simplified integration.

**Ordering Information**

RF5388	Standard 25 piece bag
RF5388SR	Standard 100 piece reel
RF5388TR7	Standard 2500 piece reel
RF5388PCK-410	Fully assembled evaluation board and 5 loose sample pieces

**Optimum Technology Matching® Applied**

- |   |                                      |  |                                   |
|---|--------------------------------------|--|-----------------------------------|
| <input type="checkbox"/> GaAs HBT             | <input type="checkbox"/> SiGe BiCMOS | <input checked="" type="checkbox"/> GaAs pHEMT | <input type="checkbox"/> GaN HEMT |
| <input type="checkbox"/> GaAs MESFET          | <input type="checkbox"/> Si BiCMOS   | <input type="checkbox"/> Si CMOS               |                                   |
| <input checked="" type="checkbox"/> InGaP HBT | <input type="checkbox"/> SiGe HBT    | <input type="checkbox"/> Si BJT                |                                   |

RF MICRO DEVICES®, RFMD®, Optimum Technology Matching®, Enabling Wireless Connectivity™, PowerStar®, POLARIS™ TOTAL RADIO™ and UltimateBlue™ are trademarks of RFMD, LLC. BLUETOOTH is a trademark owned by Bluetooth SIG, Inc., U.S.A. and licensed for use by RFMD. All other trade names, trademarks and registered trademarks are the property of their respective owners. ©2006, RF Micro Devices, Inc.

## Absolute Maximum Ratings

Parameter	Rating	Unit
Supply Voltage	-0.3 to +5.5	V <sub>DC</sub>
Power Control Voltage (PA EN)	-0.5 to +3.5	V
DC Supply Current	400	mA
Input RF Power	+10	dBm
Operating Ambient Temperature	-10 to +70	°C
Reduced Performance Temp	-30 to -10	°C
	+70 to +85	°C
Storage Temperature	-40 to +85	°C
Moisture Sensitivity	JEDEC Level MSL3	



**Caution!** ESD sensitive device.

Exceeding any one or a combination of the Absolute Maximum Rating conditions may cause permanent damage to the device. Extended application of Absolute Maximum Rating conditions to the device may reduce device reliability. Specified typical performance or functional operation of the device under Absolute Maximum Rating conditions is not implied.

RoHS status based on EUDirective2002/95/EC (at time of this document revision).

The information in this publication is believed to be accurate and reliable. However, no responsibility is assumed by RF Micro Devices, Inc. ("RFMD") for its use, nor for any infringement of patents, or other rights of third parties, resulting from its use. No license is granted by implication or otherwise under any patent or patent rights of RFMD. RFMD reserves the right to change component circuitry, recommended application circuitry and specifications at any time without prior notice.

Parameter	Specification			Unit	Condition
	Min.	Typ.	Max.		
<b>2.4GHz Transmit</b>					T=+25 °C, V <sub>CC</sub> (b/g)=3.3V, PAEN_g=2.85V, Freq=2.4GHz to 2.5GHz, unless otherwise noted.
Compliance					IEEE802.11b, IEEE802.11g FCC CFR 15.247, 0.205, 0.209
Frequency	2.4		2.5	GHz	
Output Power		14		dBm	
EVM		2		%	At 14dBm, 11g output power, RMS, Mean with a standard IEEE802.11g waveform, OFDM, 54Mbps, 64 QAM
Output Power		18		dBm	With a standard IEEE802.11g waveform at 54Mbps, 64 QAM
EVM*		4		%	At 18dBm, 11g output power, RMS, Mean with a standard IEEE802.11g waveform, OFDM, 54Mbps, 64 QAM
Output Power		20		dBm	With a standard IEEE802.11b waveform at 11Mbps, CCK
Gain	24	26		dB	
Gain Variance		±2.0		dB	Over Temperature and Frequency
Power Detect					
Voltage Range	0.1	1.8	TBD	V	For P <sub>OUT</sub> =0dBm to 20dBm in 11b mode.
Output Resistance		10		kΩ	
Output Capacitance		5		pF	
Bandwidth		8		MHz	
Sensitivity					
>10dBm	25			mV/dB	
0 < P <sub>OUT</sub> < 10dBm	8			mV/dB	
Current Operating		140		mA	RF P <sub>OUT</sub> =18dBm with a standard IEEE802.11g waveform, OFDM, 54Mbps/s, 64 QAM
		180		mA	RF P <sub>OUT</sub> =20dBm with a standard IEEE802.11b waveform, CCK, 11Mbps/s
Idle Current		100		mA	V <sub>CC</sub> =3.3V, PA EN_g=2.85V, RF=OFF
IPAEN_g		3		mA	V <sub>CC</sub> =On, PAEN_g=ON, and RF=ON
Shutdown		5		uA	V <sub>CC</sub> =On, PAEN_g=OFF, and RF=OFF

Parameter	Specification			Unit	Condition
	Min.	Typ.	Max.		
<b>2.4GHz Transmit, cont.</b>					
Power Supply	3.0	3.3	3.6	V	
PAEN_g Voltage	2.8	2.85	2.9	V	PAEN_a is in the high state (ON)
	-0.2		+0.2	V	PAEN_g is in the off state (OFF)
Switch Voltages	3.0		3.6	V	Switch voltage in the high state.
	0		0.2	V	Switch voltage in the low state.
Input Impedance		50		$\Omega$	
Output Impedance		50		$\Omega$	
Stability Output VSWR	4:1				Stable, max spurious -47 dBm
Ruggedness Output VSWR	10:1				No damage, conditions: max operating voltage, max input power
Second Harmonic	-43			dBm	Freq = 2400MHz to 2500MHz at 18dBm P <sub>OUT</sub> , RBW = 1MHz, average detector tested with 1Mbps
IEEE802.11b/g Spectral Mask per FCC Part 15.205	-43			dBm	Amplifier set up for best IEEE802.11g performance; F <sub>C</sub> = 2412MHz; RF P <sub>OUT</sub> = TBDdBm; IEEE802.11b CCK 11Mbps Modulation, T = +25°C, Measured at F <sub>C</sub> - 22MHz
IEEE802.11b/g Spectral Mask per FCC Part 15.205	-43			dBm	Amplifier set up for best IEEE802.11g performance; F <sub>C</sub> = 2462MHz; RF P <sub>OUT</sub> = TBDdBm; IEEE802.11b CCK 11Mbps Modulation, T = +25°C, Measured at F <sub>C</sub> + 22MHz
Turn-On Time		0.5	1.0	$\mu$ Sec	Output stable to within 90% of final gain
Turn-Off Time		0.5	1.0	$\mu$ Sec	Output stable to within 90% of final gain
<b>5.0GHz Transmit</b>					
Compliance					T = +25°C, V <sub>CC(a)</sub> = 3.3V, PAEN_a = 2.85V, Freq = 4.9GHz to 5.85GHz, unless otherwise noted.
Frequency	4.9		5.85	GHz	IEEE802.11a IEEE802.11j FCC CFR 15.247, 0.205, 0.209
Output Power		16		dBm	With a standard IEEE802.11a waveform, OFDM, 54Mbits/s, 64 QAM
EVM*		4	6	%	At 16dBm output power, RMS, mean with a standard IEEE802.11a waveform, OFDM, 54Mbits/s, 64 QAM at rated output power
Output Power		13		dBm	At 13dBm, 11g output power, with a standard IEEE802.11a waveform, OFDM, 54Mbits/s, 64 QAM
EVM		2		%	At 13dBm, 11g output power, with a standard IEEE802.11a waveform, OFDM, 54Mbits/s, 64 QAM
Gain	23	25		dB	
Gain Variance		±2.0		dB	
Power Detect					
Voltage Range	0.7	1.5	TBD	V	At P <sub>OUT</sub> range of 0dBm to 16dBm with a standard IEEE802.11a waveform.
Output Resistance		10		k $\Omega$	
Output Capacitance		1		pF	
Bandwidth		8		MHz	

Parameter	Specification			Unit	Condition
	Min.	Typ.	Max.		
<b>5.0GHz Transmit, cont.</b>					
Sensitivity					
>10dBm	25			mV/dB	
0 < P <sub>OUT</sub> < 10dBm	8			mV/dB	
Current Operating		150		mA	RF P <sub>OUT</sub> = +16dBm, RMS, mean with a standard IEEE802.11g waveform, OFDM, 54Mbps/s, 64 QAM at rated output power
Idle Current		100		mA	V <sub>CC</sub> = 3.3V, PA EN_a = 2.85V, RF = OFF
IPAEN_a		8		mA	
Shutdown		5		μA	
PAEN_a Supply Voltage	3.0	3.3	3.6	V	
PA EN_a Voltage	2.8	2.85	2.9	V	PAEN_a is in the high state (ON)
	-0.2		+0.2	V	PAEN_a is in the off state (OFF)
Switch Voltages	3.0		3.6	V	Switch voltage in the high state.
	0		0.2	V	Switch voltage in the low state.
Input Impedance		50		Ω	
Output Impedance		50		Ω	
Stability Output VSWR	3:1				Stable, max spurious -47 dBm Conditions: max operating voltage, max input power
Ruggedness Output VSWR	10:1				No damage, conditions: max operating voltage, max input power
Second Harmonic	-30			dBm	At P <sub>OUT</sub> = +16dBm, measured in 1MHz RBW with 6Mbps 11a signal, Fundamental Frequency is between 4.9GHz to 5.299GHz.
	-43			dBm	At P <sub>OUT</sub> = +16dBm, measured in 1MHz RBW with 6Mbps 11a signal, Fundamental Frequency is between 5.3GHz to 5.85GHz.
IEEE802.11a Spectral Mask per FCC Part 15.205	-43			dBm	Amplifier set up for best IEEE802.11a performance; F <sub>C</sub> = 5180MHz; RF P <sub>OUT</sub> = +16dBm; T = +25 °C, Measured at 5150MHz
IEEE802.11a Spectral Mask per FCC Part 15.205	-43			dBm	Amplifier set up for best IEEE802.11a performance; F <sub>C</sub> = 5320MHz; RF P <sub>OUT</sub> = +16dBm; T = +25 °C, Measured at 5350MHz
Turn-On Time		0.5	1.0	μSec	Output stable to within 90% of final gain
Turn-Off Time		0.5	1.0	μSec	Output stable to within 90% of final gain
Antenna Port Impedance					
	Input		50	Ω	
Output		50		Ω	

Parameter	Specification			Unit	Condition
	Min.	Typ.	Max.		
<b>2.4GHz Receive</b>					
Compliance					IEEE802.11b IEEE802.11g FCC CFR 15.247, 0.205, 0.209
Frequency	2.4		2.5	GHz	
Insertion Loss		2.3		dB	SPDT switch + diplexer
Noise Figure		2.3		dB	SPDT switch + diplexer
Passband Ripple	-0.3		+0.3	dB	
Output Return Loss		-10		dB	
Current Consumption			30	μA	Switch leakage current
Switch Voltages	3.0		3.6	V	Switch voltage in the high state.
	0		0.2	V	Switch voltage in the low state.
<b>5.0GHz Receive</b>					
Compliance					IEEE802.11a IEEE802.11j FCC CFR 15.247, 0.205, 0.209
Frequency	4.9		5.85	GHz	
Receive Gain		9		dB	
Noise Figure		4.5	4.9	dB	SPDT switch + diplexer
Input P1dB		-5		dBm	
Input IP3		+5		dBm	
Passband Ripple		±1		dB	
Output Return Loss		-10		dB	
Current Consumption		15		mA	
Switch Leakage Current			30	uA	
LNA V <sub>CC</sub>	3.0	3.3	3.6	V	LNA V <sub>CC</sub> is in the high state
	-0.2		+0.2	V	LNA V <sub>CC</sub> is in the low state
Switch Voltages	3.0		3.6	V	Switch voltage in the high state.
	0		0.2	V	Switch voltage in the low state.

\*The EVM specification includes a 0.5% to 0.7% source EVM floor.

Pin	Function	Description	Interface Schematic
1	LNA VCC	5GHz LNA input voltage supply.	
2	GND	Ground connection.	
3	GND	Ground connection.	
4	PA EN_g	Bias voltage for the 802.11b/g PA. Internally decoupled port with approximately 100pF.	
5	GND	Ground connection.	
6	TX_g	RF input for the 802.11b/g PA. Input is matched to 50Ω and DC block is provided internally.	
7	GND	Ground connection.	
8	TX_a	TX RF input for the 802.11a PA. Input is matched to 50Ω and DC block is provided internally.	
9	GND	Ground Connection.	
10	PA EN_a	Bias voltage for the 802.11a PA. Internally decoupled port with approximately 100pF.	
11	GND	Ground connection.	
12	GND	Ground connection.	
13	GND	Ground connection.	
14	VCC_g	Supply voltage for the 11b/g amplifier. Requires external decoupling capacitors for best performance.	
15	VCC_a	Supply voltage for the 11a amplifier. Requires external decoupling capacitors for best performance.	
16	VCC_g	Supply voltage for the 11b/g amplifier. Requires external decoupling capacitors for best performance.	
17	VCC_a	Supply voltage for the 11a amplifier. Requires external decoupling capacitors for best performance.	
18	VCC_a	Supply voltage for the 11a amplifier. Requires external decoupling capacitors for best performance.	
19	PDET_a	Power detector voltage for the 802.11a PA. Pdetect voltage varies with output power. May need external decoupling capacitor for module stability. May need resistive voltage divider to bring output voltage to desired level.	
20	PDET_g	Power detector voltage for the 802.11b/g PA. Pdetect voltage varies with output power. May need external decoupling capacitor for module stability. May need resistive voltage divider to bring output voltage to desired level.	
21	GND	Ground connection.	
22	GND	Ground connection.	
23	NC	No Connect.	
24	GND	Ground connection.	
25	VCC_g	Supply voltage for the 11b/g amplifier. Requires external decoupling capacitors for best performance.	
26	VCC_g	Supply voltage for the 11b/g amplifier. Requires external decoupling capacitors for best performance.	
27	SW1	Switch control port. (See Switch Truth table.)	
28	ANT	Antenna port. This port is matched to 50Ω and DC block is <b>not</b> provided internally.	
29	GND	Ground connection.	
30	NC	No Connect.	
31	SW2	Switch control port. (See Switch Truth table.)	
32	GND	Ground connection.	
33	GND	Ground connection.	
34	GND	Ground connection.	

Pin	Function	Description	Interface Schematic
35	GND	Ground connection.	
36	RX_g	Receive port for 802.11b/g band. Internally matched to 50Ω and DC block is <i>not</i> provided internally.	
37	GND	Ground connection.	
38	RX_a	Receive port for 802.11a band. Internally matched to 50Ω and DC block is provided internally.	
39	GND	Ground connection.	
40	GND	Ground connection.	
Pkg Base	GND	Ground connection. The back side of the package should be connected to ground plane through as short a connection as possible (e.g., PCB vias under the device are recommended).	

**Switch Truth Table**

Mode #	Description	SW1	SW2	PA EN_a	PA EN_g	LNA EN
1	Transmit, 2.4GHz	H	L	L	H	L
2	Receive, 2.4GHz	L	H	L	L	L
3	Transmit, 5.0GHz	H	L	H	L	L
4	Receive, 5.0GHz	L	H	L	L	H

**Package Drawing**

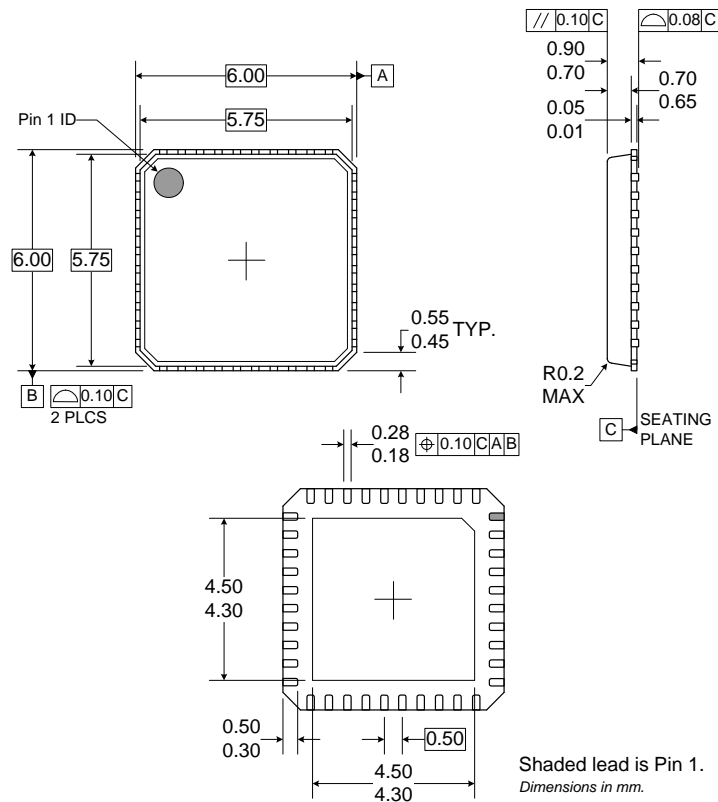

## Pin Out (Top View)

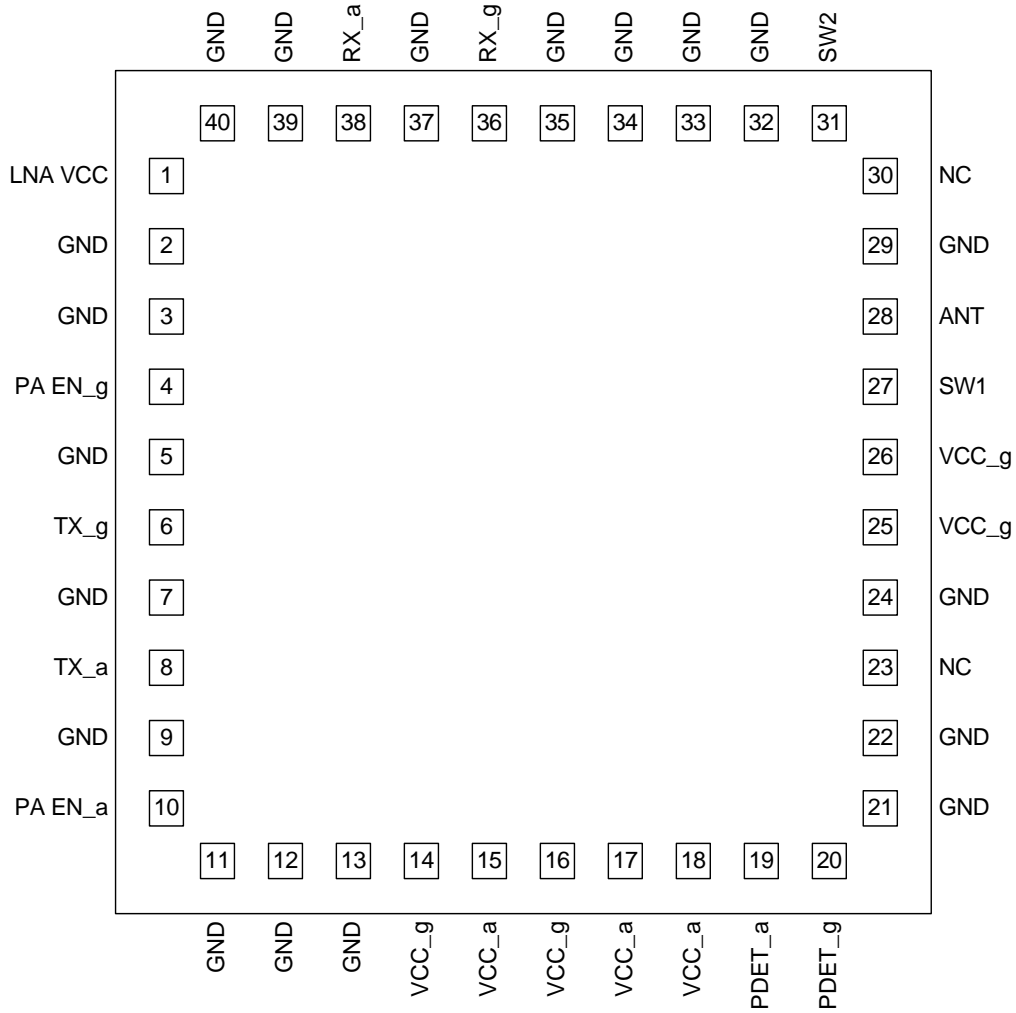



### Application Schematic

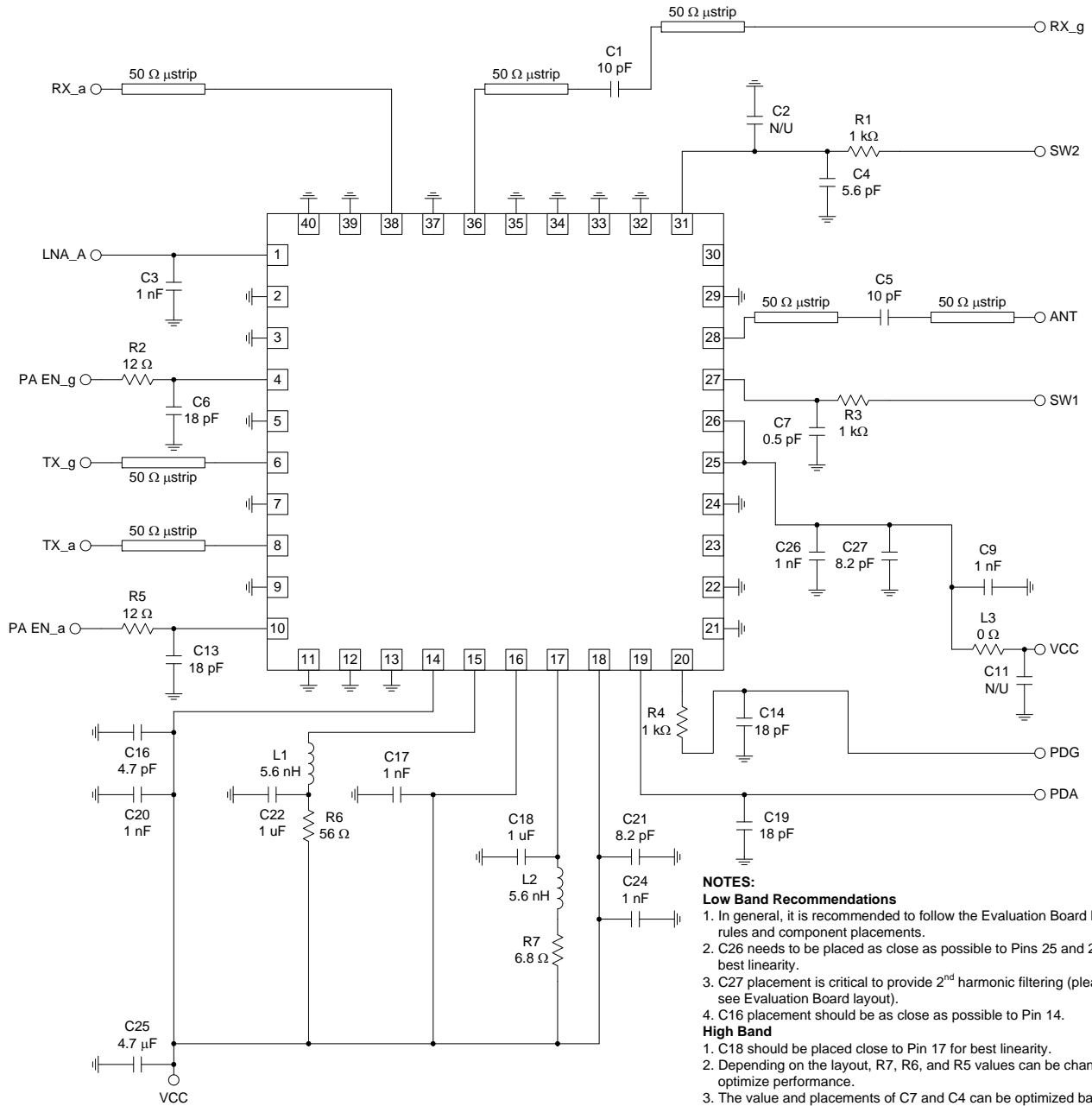

**NOTES:**

**Low Band Recommendations**

1. In general, it is recommended to follow the Evaluation Board layout rules and component placements.
2. C26 needs to be placed as close as possible to Pins 25 and 26 for best linearity.
3. C27 placement is critical to provide 2<sup>nd</sup> harmonic filtering (please see Evaluation Board layout).
4. C16 placement should be as close as possible to Pin 14.

**High Band**

1. C18 should be placed close to Pin 17 for best linearity.
2. Depending on the layout, R7, R6, and R5 values can be changed to optimize performance.
3. The value and placements of C7 and C4 can be optimized based on the layout for best performance.

**General Note**

Depending on the layout, C20, C24, C11, L3, C2, C3, C6, C13 can all be unused without affecting the performance. It is recommended that the footprints be added on first layout, and once the design is proven they can be eliminated to reduce the component count.

## Evaluation Board Schematic

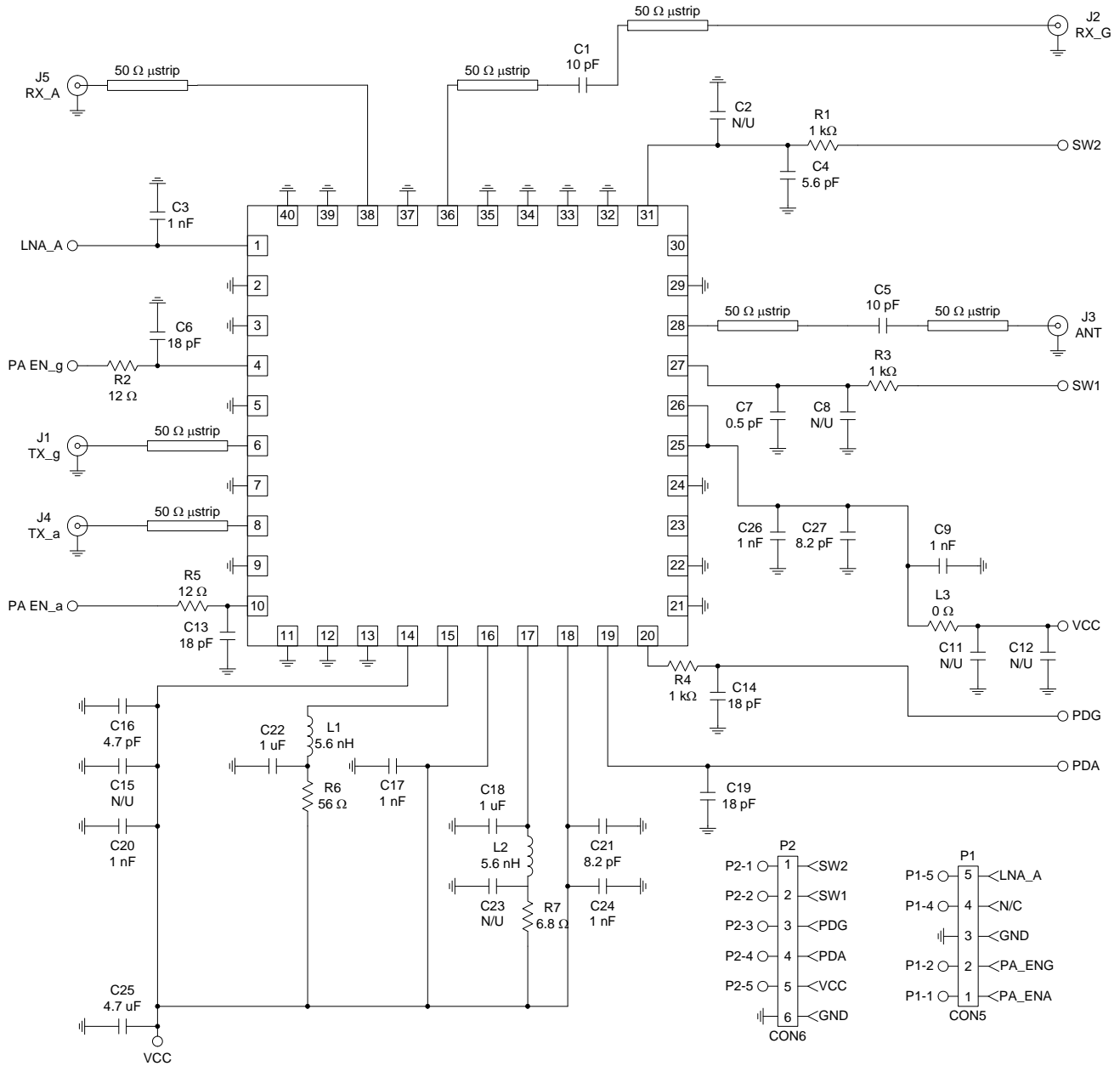

**Evaluation Board Layouts**  
**Board Size 1.5" x 1.5"**

**Board Thickness 0.032", Board Material FR-4, Multi-Layer**

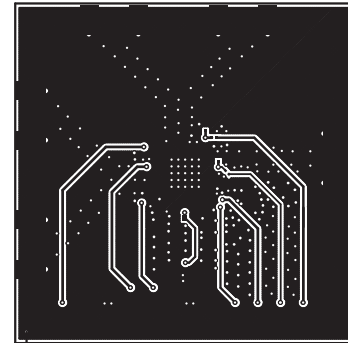
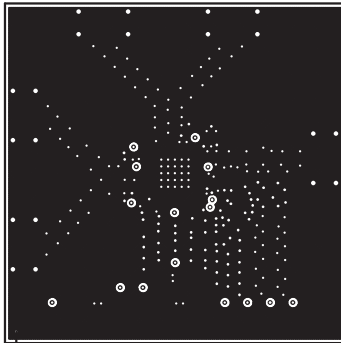
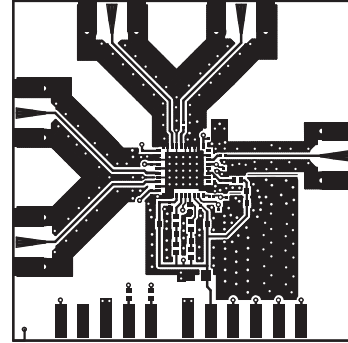
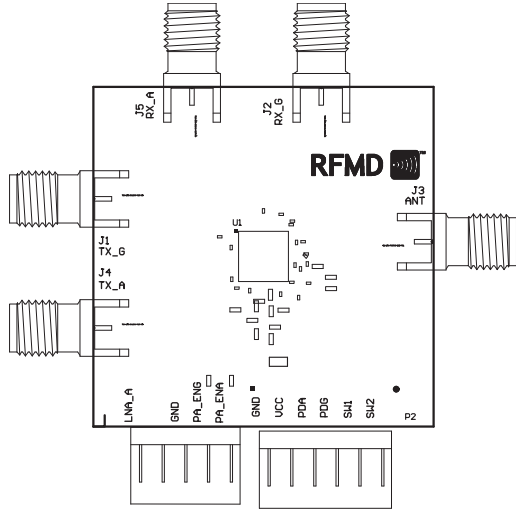

## Theory of Operation

The RF5388 is a single-chip dual-band integrated front-end module (FEM) for high performance WiFi applications in the 2.5GHz and 5GHz ISM bands. The RF5388 addresses the need for aggressive size reduction for a typical 802.11a/b/g RF front-end design and greatly reduces the number of components outside of the core chipset thus minimizing the footprint and assembly cost of the overall 802.11a/b/g/n solution. The RF5388 contains integrated PA's for 2.5GHz and 5GHz, diplexers, TX/RX switch, LNA for the 5.0GHz receive band, matching components, some bypass capacitors, built-in power detector for both bands, and filters for transmit and receive paths. The RF5388 is packaged in a 40-pin, 6mmx6mmx0.9mm QFN package with backside ground which greatly minimizes next level board space and allows for simplified integration.

The RF5388 is designed primarily for IEEE802.11 b/g/a/n WiFi applications where the available supply voltage and current are limited. The RF5388 has one transmit path for a/b/g operation but it has two power amplifiers, one for the low band (b/g) and one for the high band (11a). The RF5388 requires a single positive supply voltage ( $V_{CC}$ ), positive current control bias (PAEN) supply for each band, and a positive supply for switch control to simplify bias requirements. The RF5388 FEM also has built in power detectors for both 11b/g PA and 11a PA. All inputs and outputs are internally matched to  $50\Omega$ .

### 802.11b/g Transmit Path

The RF5388 low band power amplifier operates at frequencies between 2.4GHz to 2.5GHz and has a typical gain of 26dB and delivers 18dBm typical output power under 54Mbps OFDM modulation meeting the specified Error Vector Magnitude (EVM) and >20dBm under 11Mbps CCK modulation meeting the spectral mask. The RF5388 requires a single positive supply of 3.0V to 3.6V to operate at full specifications. Current control optimization for the 802.11b/g band is provided through one bias control input pin (PAEN\_g). The PAEN\_g pin requires a regulated supply to maintain nominal bias current. In general, higher PAEN\_g voltage produce higher linear output power, higher operating current and higher gain but this voltage should be set in the range that it is specified. Second and third harmonic filtering is provided on the die so that the second and third harmonics level are well below -41.3dBm and passes the FCC restricted band requirements.

For best performance of the low band transmit path care has to be taken with the placement and values of some of the components around the FEM. We recommend that the layout of the evaluation board should be copied as close as possible to prevent any performance degradation. From one layout to another, the space and parts placement can change therefore, these are important recommendations one has to keep in mind (Please refer to the evaluation board schematic):

- For best linearity C26 and C16 should be placed as close to the FEM as possible.
- For best harmonic rejection, the combination of C26, C27, C9, L3, C11, and C12 placement and values are important. It is recommended to follow the evaluation board layout for best performance. Also the value and placement of C7, C8, C2, and C4 are important for harmonic rejection so care has to be taken on the placement and values of these parts.
- All RF transmission lines should be as close as possible to  $50\Omega$  no matter what the stack is and what board material is used.
- We recommend that you contact RFMD application support to review your schematics and layout to provide recommendations.

### 802.11a Transmit Path:

The RF5388 high band power amplifier operates at frequencies between 4.9GHz to 5.85GHz and has a typical gain of 26dB and delivers 16dBm typical output power under 54Mbps OFDM modulation meeting the specified EVM. The RF5388 requires a single positive supply of 3.0V to 3.6V to operate at full specifications. Current control optimization for the 802.11a band is provided through one bias control input pin (PAEN\_a). The PAEN\_a pin requires a regulated supply to maintain nominal bias current. In general, higher PAEN\_a voltage produce higher linear output power, higher operating current and higher gain but this voltage should be set in the range that it is specified as per the data sheet. Second and third harmonic filtering is provided on the die so that the second and third harmonics level are well below -30dBm for the bands that are not restricted by the FCC and <-41.3dBm for bands that are restricted by the FCC.

For best performance of the high band transmit path care has to be taken with the placement and values of some of the components around the FEM. We recommend that the layout of the evaluation board should be copied as close as possible to prevent any performance degradation. From one layout to another, the space and parts placement can change therefore, these are important recommendations one has to keep in mind (Please refer to the evaluation board schematic):

- For best linearity, the combination of components on Pins 14, 17, and 18 should be copied as per the evaluation board. The placement of these components should be as close to the FEM as possible.
- All RF transmission lines should be as close as possible to 50Ω.
- We recommend that you contact RFMD application support to review your layout and to provide recommendations.

**802.11b/g Receive Path**

The 802.11b/g path has 50Ω impedance with a nominal insertion loss and noise figure of 2dB. The RX port return loss is -10dB Typical. Depending on the application, if filtering is required beyond what the RF5388 can achieve then additional external filters will need to be added outside of the RF5388.

**802.11a Receive Path**

The 802.11a path has 50Ω impedance with a nominal gain of 9dB and 4.5dB typical noise figure pin to pin. The RX port return loss is -10dB typical. Depending on the application, if filtering is required beyond what the RF5388 can achieve then additional external filters will need to be added outside of the RF5388.

**Biasing instruction for TX Measurements:**

- Connect (TX\_a or TX\_g) to RFIN from the signal Generator and ANT to RFOUT to the signal analyzer.
- Terminate all unused ports to 50Ω.
- Connect GND first and then the bias pins (V<sub>CC</sub>) which is common between V<sub>CC-a</sub> and V<sub>CC-g</sub> but make sure the V<sub>CC</sub> is off at this point.
- Connect Switch Control pins (SW1 and SW2) with all set to 0V.
- Set compliance on PAEN\_a / PAEN\_g to <10mA.
- Set compliance on V<sub>CC</sub> to <300mA.
- Set SW1=HighV or equal to V<sub>CC</sub> and turn on.
- Connect SW2 to GND for both 11a and 11g TX operation.
- Set VCC = 3.30V and turn on.
- Set PAEN\_a / PAEN\_g = 2.85V and turn on. With no RF drive the part should draw ~ 100 -130mA quiescent current for either 11a or 11g bands.
- Turn RF signal on from the signal Generator.
- Perform measurements.
- Follow reverse procedure to turn part off.
- Max RFIN power allowed is +5dBm.

Typical  $I_{PAEN\_G}$  versus  $P_{OUT}$  @  $V_{CC}=3.3V$ ,  $PAEN\_G=2.85V$ , and @  $25^{\circ}C$

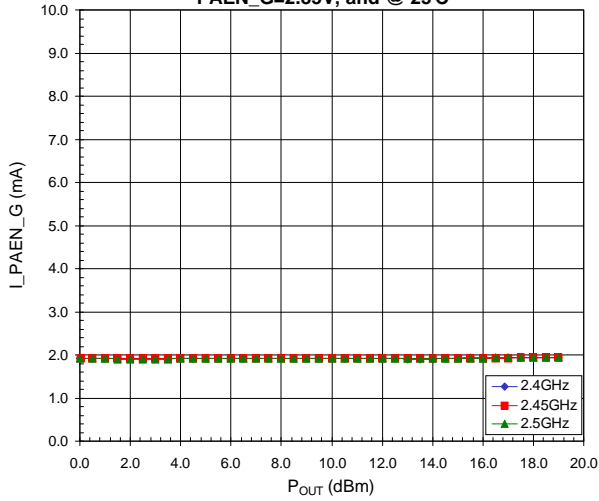

Typical  $P_{DET}$  versus  $P_{OUT}$  @  $V_{CC}=3.3V$ ,  $PAEN\_G=2.85V$  and @  $25^{\circ}C$

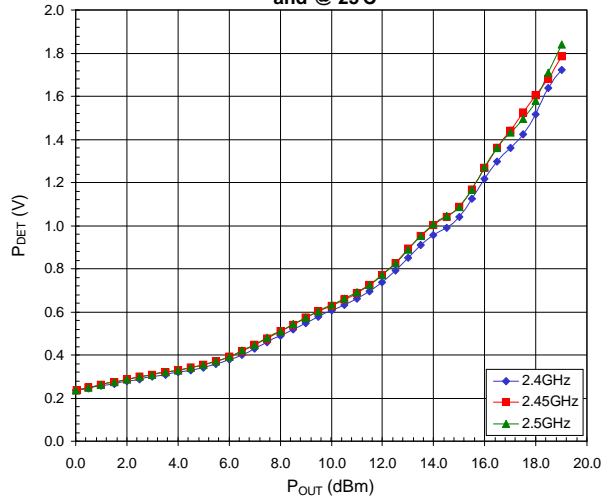

Typical Gain versus  $P_{OUT}$  @  $V_{CC}=3.3V$ ,  $PAEN\_G=2.85V$ , and @  $25^{\circ}C$

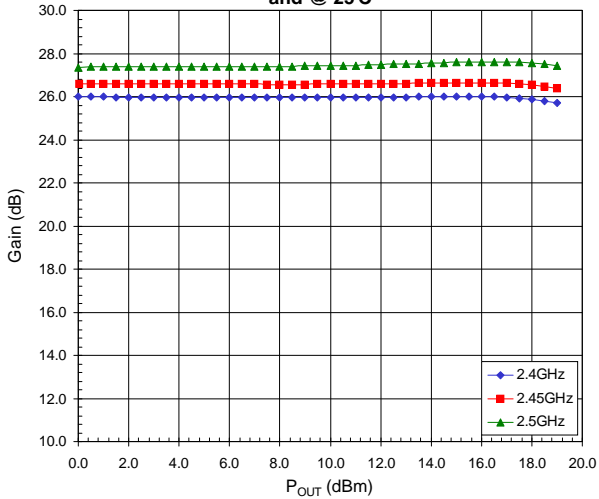

Typical  $I_{CC}$  versus  $P_{OUT}$  @  $V_{CC}=3.3V$ ,  $PAEN\_G=2.85V$ , and @  $25^{\circ}C$

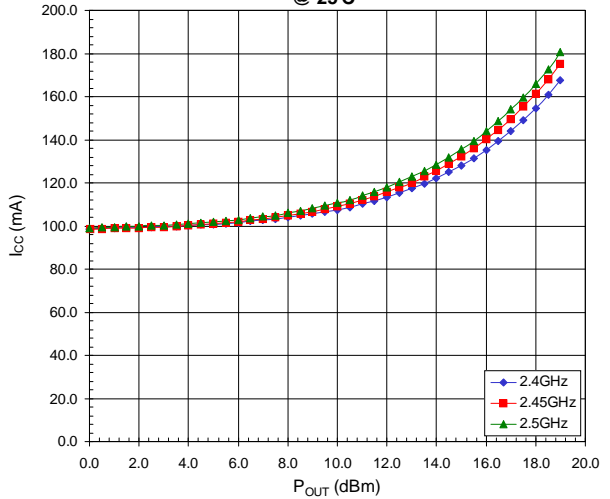

Typical EVM versus  $P_{OUT}$  @  $V_{CC}=3.3V$ ,  $PAEN\_G=2.85V$ , and @  $25^{\circ}C$

