



Features

- Tx Output Power: 30dBm
- Separate 50Ω Tx/Rx Transceiver
- InterfaceRx Insertion Loss: 1dB

Applications

- Wireless Automated Metering
- Wireless Alarm Systems
- Portable Battery Powered Equipment
- Smart Energy
- 433MHz/450MHz to 470MHz ISM Band Application
- Single Chip RF Front End Module

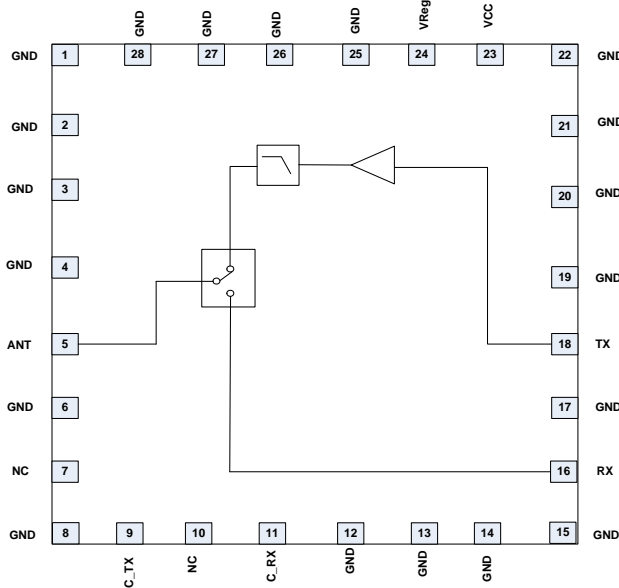

Functional Block Diagram

Product Description

RF6504 is a front end module (FEM) intended for 433MHz to 470MHz AMI/AMR systems. This module provides separate ports for Rx and Tx paths. The Tx section provides a PA with nominal output power of 30dBm and gain of 15dB. The Rx is a pass through. Both are combined to a single antenna port with a SP2T switch. The device is provided in a 5.5mm x 5.0mm, 28-pin package.

Ordering Information

RF6504	ISM Band Front End Module
RF6504SB	5-Piece Bag
RF6504SR	Standard 100-Piece Reel
RF6504TR7	Standard 750-Piece Reel
RF6504TR13	Standard 2500-Piece Reel
RF6504PCK-410	Fully Assembled Evaluation Board and 5-Piece Bag

Optimum Technology Matching® Applied

- | | | | |
|---|--------------------------------------|--|------------------------------------|
| <input type="checkbox"/> GaAs HBT | <input type="checkbox"/> SiGe BiCMOS | <input checked="" type="checkbox"/> GaAs pHEMT | <input type="checkbox"/> GaN HEMT |
| <input type="checkbox"/> GaAs MESFET | <input type="checkbox"/> Si BiCMOS | <input type="checkbox"/> Si CMOS | <input type="checkbox"/> BiFET HBT |
| <input checked="" type="checkbox"/> InGaP HBT | <input type="checkbox"/> SiGe HBT | <input type="checkbox"/> Si BJT | |

RF MICRO DEVICES®, RFMD®, Optimum Technology Matching®, Enabling Wireless Connectivity™, PowerStar®, POLARIS™ TOTAL RADIO™ and UltimateBlue™ are trademarks of RFMD, LLC. BLUETOOTH is a trademark owned by Bluetooth SIG, Inc., U.S.A. and licensed for use by RFMD. All other trade names, trademarks and registered trademarks are the property of their respective owners. ©2012, RF Micro Devices, Inc.

Absolute Maximum Ratings

Parameter	Rating	Unit
Battery Voltage	5	V
RF Port Impedance	50	Ω
Operating Temperature	-30 to 70	$^{\circ}\text{C}$
Storage Temperature	-40 to 85	$^{\circ}\text{C}$
ESD, HBM (RF pins)	500	V
ESD, HBM (All pins)	500	V
ESD, CDN (RF pins)	500	V
ESD, CDM (all pins)	500	V
MSL	MSL 3	
Maximum Input Power to PA	+20	dBm



Caution! ESD sensitive device.

Exceeding any one or a combination of the Absolute Maximum Rating conditions may cause permanent damage to the device. Extended application of Absolute Maximum Rating conditions to the device may reduce device reliability. Specified typical performance or functional operation of the device under Absolute Maximum Rating conditions is not implied.

The information in this publication is believed to be accurate and reliable. However, no responsibility is assumed by RF Micro Devices, Inc. ("RFMD") for its use, nor for any infringement of patents, or other rights of third parties, resulting from its use. No license is granted by implication or otherwise under any patent or patent rights of RFMD. RFMD reserves the right to change component circuitry, recommended application circuitry and specifications at any time without prior notice.



RFMD Green: RoHS compliant per EU Directive 2002/95/EC, halogen free per IEC 61249-2-21, < 1000ppm each of antimony trioxide in polymeric materials and red phosphorus as a flame retardant, and <2% antimony in solder.

Parameter	Specification			Unit	Condition
	Min.	Typ.	Max.		
					Specifications are at nominal supply voltage, control voltage, and temperature. Characterization will be done over full voltage and temperature range specified.
Frequency	433	450 to 470		MHz	
RF Port Impedance		50		Ω	
Total Leakage Current		4	5	μA	$V_{\text{REG}} = 0\text{V}$
ESD, HBM	500			V	RF pins
	500			V	All other pins
ESD, CDM	500			V	RF pins
	500			V	All other pins
PA Section					
CW P_{OUT} Saturation	30			dBm	PA P_{SAT} - Sw(1dB) - Filt(1dB)
Large Signal Gain	13	15		dB	Input PA to Output of Switch
Input Power	17			dBm	
2Fo to 10Fo	-54	-60		dBc	
Input Return Loss	10			dB	
Battery Voltage	3.3	3.6	4.0	V	V_{CC}
Battery Current		850		mA	$V_{\text{CC}} = 3.6\text{V}$, PA PAE 55%
Power Down Current		0.3	2	μA	$V_{\text{CC}} = 3.6\text{V}$, $V_{\text{REG}} = 0\text{V}$
V_{REG}	3.1	3.4	3.8	V	$V_{\text{CC}} = 0.2\text{V}$
V_{REG} Current		3	4	mA	
RX Section					
Noise Figure		0.7	1	dB	
Input IP3	12	18		dBm	
Input Return Loss	10			dB	
Output Return Loss	10			dB	

Parameter	Specification			Unit	Condition
	Min.	Typ.	Max.		
Antenna Switch Section					
Isolation	20			dB	Any used port to any unused port
Logic Voltage, High	3.1	3.4	3.8	V	All Logic I/O's, V _{BAT} = 0.2V
Logic Voltage, Low	0.0	0.2	0.4	V	All Logic I/O's
Logic Current, High		5	10	μA	All Logic I/O's
Logic Current, Low		0.4		μA	All Logic I/O's
Current					
ANT1		50		μA	ANT_SEL = HIGH, V _{REG} = Low, TXRX_Sel = Low
Power Down Mode, ANT2		1.7		μA	ANT_SEL = LOW, V _{REG} = Low, TXRX_Sel = Low

Operating Mode	Module Logic Truth Table		Typ. Battery Current at P _{OUT} = 30dBm
	C_TX	C_RX	
TX-ANT	1	0	850mA
RX-ANT	0	1	0.3μA

Pin	Function	Description
5	ANT	Antenna Connect Port.
9	C_TX	Transmit Selection Control Line.
11	C_RX	Receive Selection Control Line.
16	RX	Receive Port.
18	TX	Transmit Port.
23	VCC	Power Amplifier Supply Voltage.
24	VREG	Power Amplifier Bias Control. V _{CC} to 0.2V = ON, 0V = OFF.
7, 10	NC	
1, 2, 3, 4, 6, 8, 12, 13, 14, 15, 17, 19, 20, 21, 22, 25, 26, 27, 28	GND	Ground.

Package Drawing

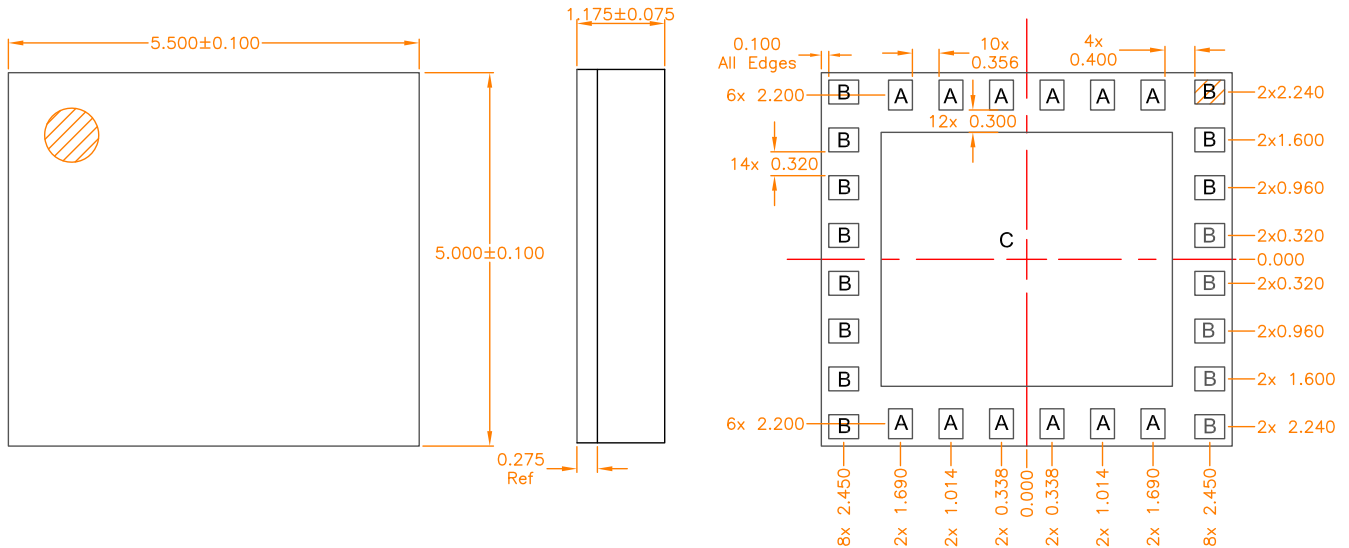

Notes:
1. Shaded area represents Pin 1 location.

A = 0.320 x 0.400 mm
B = 0.400 x 0.320 mm
C = 3.900 x 3.400 mm

All units in μm .

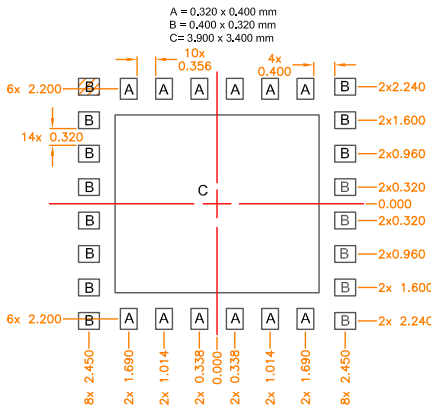

PCB Metal Land Pattern

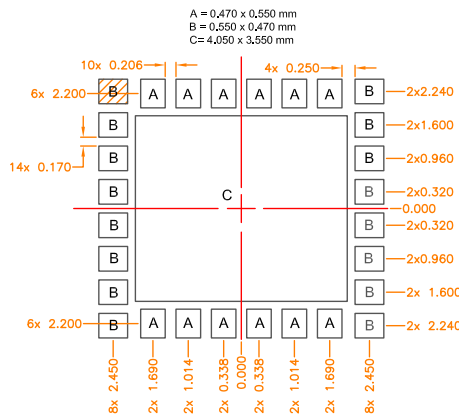

PCB Solder Mask Pattern

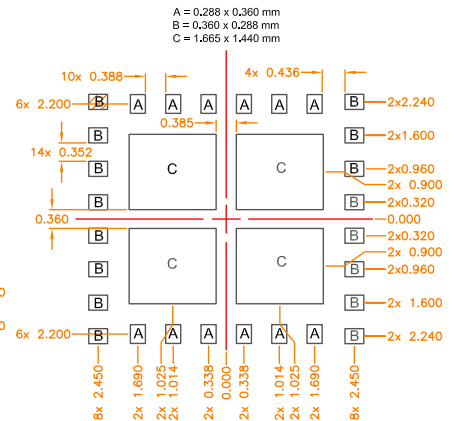

PCB Stencil Pattern

Notes:
1. Shaded area represents Pin 1 location.

Application Schematic

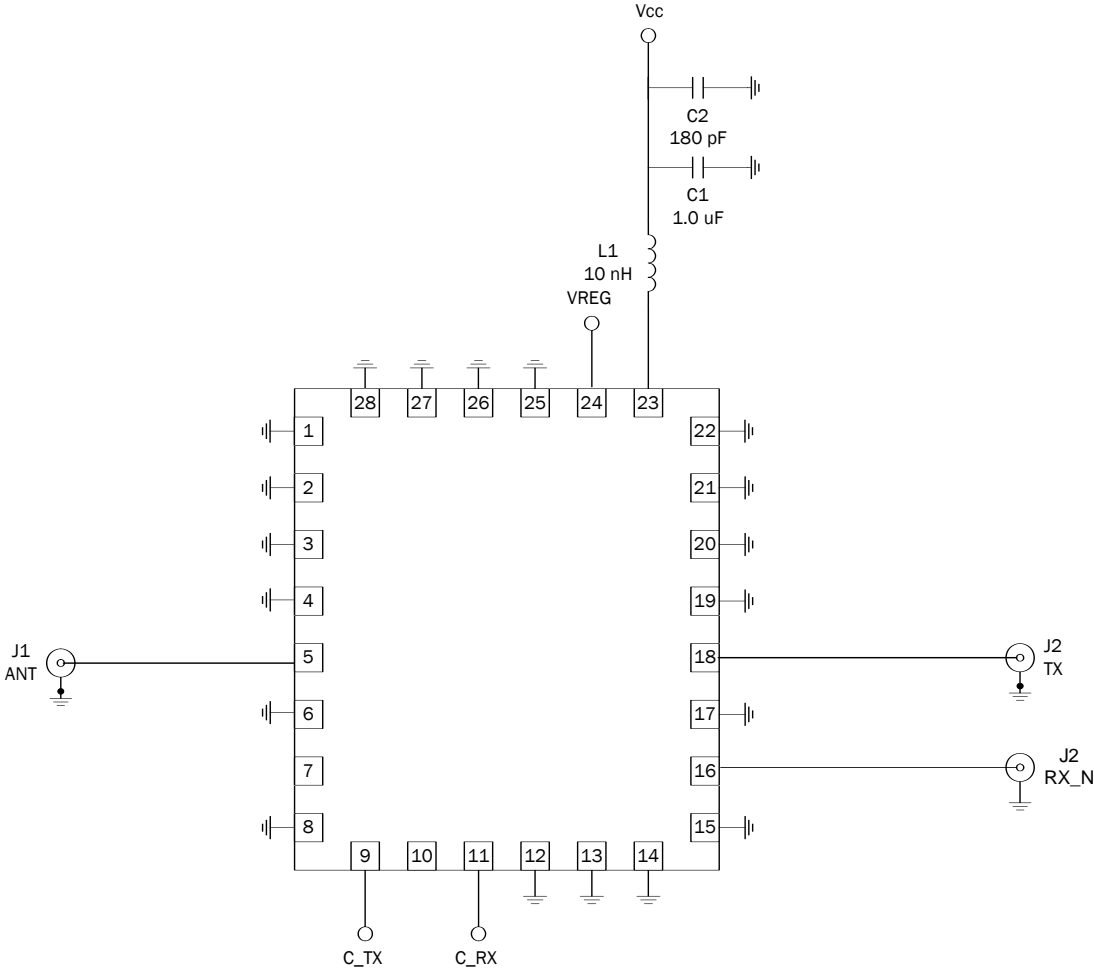

Typical Performance

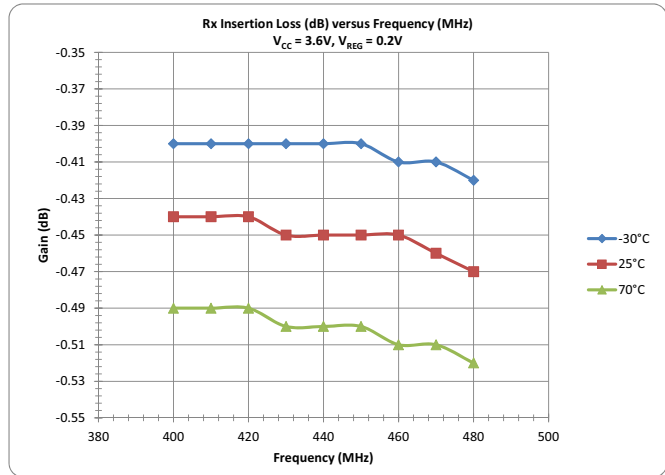
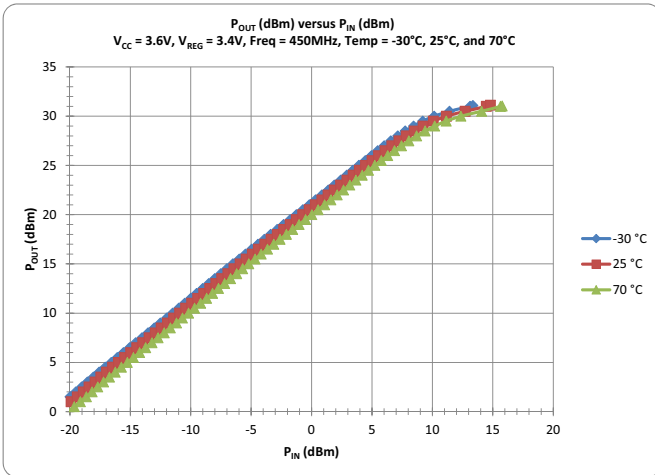
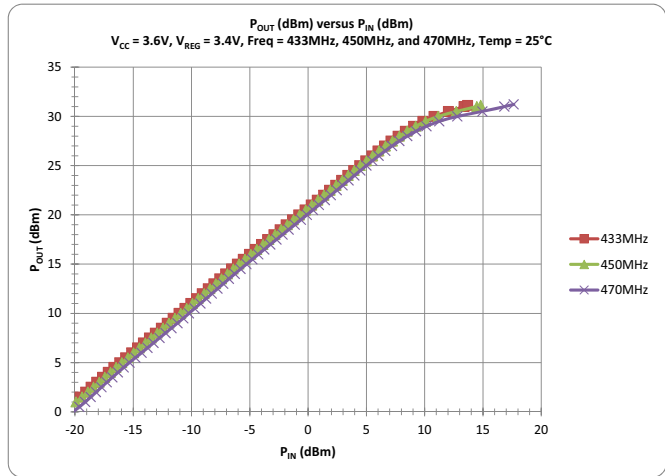
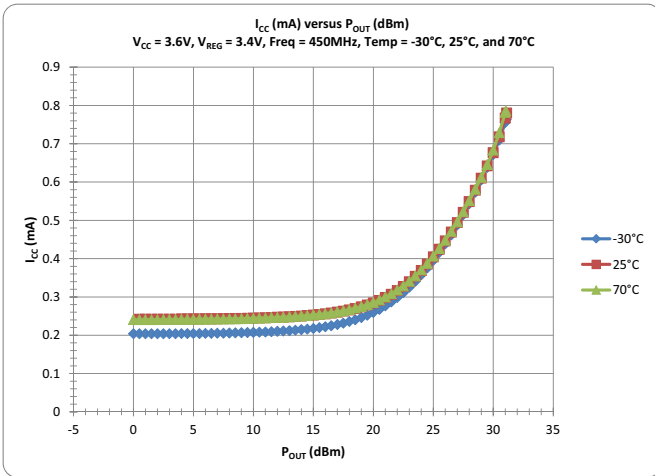
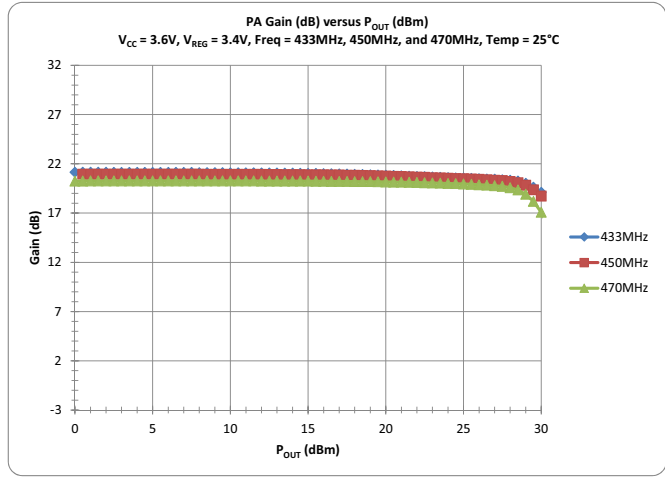
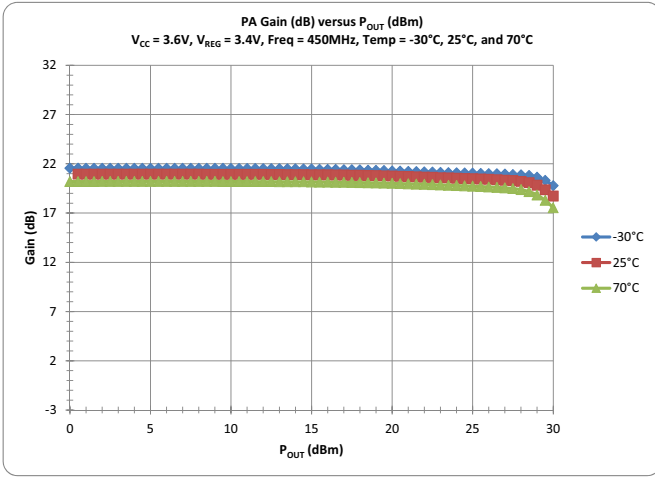

Typical Performance

