



Package Style: QFN, 20-Pin, 3.5mmx3.5mmx0.5mm



Features

- TX Output Power = 22dBm
- Integrated RF Front End Module with TX/RX switch, PA, filter, LNA, and DP2T switch.
- 50Ω single-ended bidirectional Transceiver interface.

Applications

- ZigBee® 802.15.4 Based Systems for Remote Monitoring and Control
- WiFi 802.11b/g
- 2.4GHz ISM band applications
- Smart Meters for Energy Management

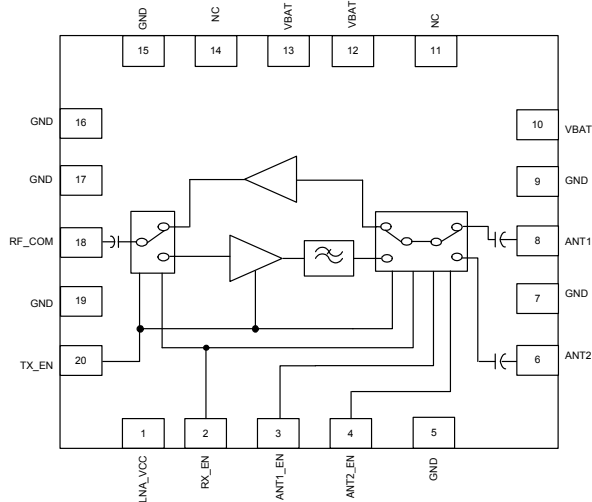

Functional Block Diagram

Product Description

The RF6575 integrates a complete solution in a single Front End Module (FEM) for WiFi and ZigBee® applications in the 2.4GHz to 2.5GHz band. This FEM integrates the PA plus harmonic filter in the transmit path. The RF6575 has an integrated LNA. Also, the RF6575 provides a single balanced TDD access for RX and TX paths along with two ports on the output for connecting a diversity solution or a test port. The device is provided in a 3.5mm x 3.5mm x 0.5, 20-pin QFN package.

Ordering Information

RF6575	3.3V Front End Module for AMR systems in the 2.4GHz to 2.5GHz Band
RF6575SQ	Standard 25 piece bag
RF6575SR	Standard 100 piece reel
RF6575TR13	Standard 2500 piece reel
RF6575PCK-410	Fully assembled evaluation board and 5 loose pieces

Optimum Technology Matching® Applied

- | | | | |
|---|--------------------------------------|--|------------------------------------|
| <input type="checkbox"/> GaAs HBT | <input type="checkbox"/> SiGe BiCMOS | <input checked="" type="checkbox"/> GaAs pHEMT | <input type="checkbox"/> GaN HEMT |
| <input type="checkbox"/> GaAs MESFET | <input type="checkbox"/> Si BiCMOS | <input type="checkbox"/> Si CMOS | <input type="checkbox"/> BIFET HBT |
| <input checked="" type="checkbox"/> InGaP HBT | <input type="checkbox"/> SiGe HBT | <input type="checkbox"/> Si BJT | <input type="checkbox"/> LDMOS |

RF MICRO DEVICES®, RFMD®, Optimum Technology Matching®, Enabling Wireless Connectivity™, PowerStar®, POLARIS™ TOTAL RADIO™ and UltimateBlue™ are trademarks of RFMD, LLC. BLUETOOTH is a trademark owned by Bluetooth SIG, Inc., U.S.A. and licensed for use by RFMD. All other trade names, trademarks and registered trademarks are the property of their respective owners. ©2006, RF Micro Devices, Inc.

Absolute Maximum Ratings

Parameter	Rating	Unit
DC Supply Voltage	5.5	V
DC Supply Current	250	mA
Operating Case Temperature	-40 to +85	°C
Storage Temperature	-40 to +150	°C
ESD Human Body Model RF Pins	1000	V
ESD Human Body Model All Other Pins	500	V
ESD Charge Device Model All Pins	500	V
Moisture Sensitivity Level	MSL 2	
Maximum Input Power to PA	+10	dBm
Maximum Input Power to LNA	+5	dBm



Caution! ESD sensitive device.

Exceeding any one or a combination of the Absolute Maximum Rating conditions may cause permanent damage to the device. Extended application of Absolute Maximum Rating conditions to the device may reduce device reliability. Specified typical performance or functional operation of the device under Absolute Maximum Rating conditions is not implied.

RoHS status based on EUDirective2002/95/EC (at time of this document revision).

The information in this publication is believed to be accurate and reliable. However, no responsibility is assumed by RF Micro Devices, Inc. ("RFMD") for its use, nor for any infringement of patents, or other rights of third parties, resulting from its use. No license is granted by implication or otherwise under any patent or patent rights of RFMD. RFMD reserves the right to change component circuitry, recommended application circuitry and specifications at any time without prior notice.

Parameter	Specification			Unit	Condition
	Min.	Typ.	Max.		
Overall					Specifications must be met across supply voltage, control voltage, and temperature ranges unless otherwise specified.
V _{BATT}	3.0	3.3	3.6	V _{DC}	
Operating Temperature Range	-40	+25	+85	°C	
Z ₀		50		Ω	
Off Mode Current		1		μA	All logic low
TX Path					
Frequency	2400		2483	MHz	
Input Return Loss	12			dB	
Output Return Loss	9			dB	
Transmit Path Gain	24	28		dB	
Gain Flatness	-0.8		+0.8	dB	
Rated Output Power		22		dBm	Nominal conditions
	20			dBm	All conditions
Supply Current		200		mA	P _O = 22 dBm 802.15.4 OQPSK
		170		mA	P _O = 20 dBm 802.15.4 OQPSK
		130		mA	P _O = 16 dBm 802.15.4 OQPSK
Thermal Resistance		66		°C/W	V _{CC} = 3.6V, P _{OUT} = 22dBm, T _{REF} = 85 °C
2nd harmonic level			-42	dBm/MHz	P _O = 20 dBm
3rd harmonic level			-42	dBm/MHz	P _O = 20 dBm
VSWR Stability and Load	4:1				
VSWR No Damage	8:1				
Gain Settling Time		1	2	μS	

Parameter	Specification			Unit	Condition
	Min.	Typ.	Max.		
RX Path					
Frequency	2400		2483	MHz	
Gain	10	13	15.5	dB	
Noise Figure		2.5	3	dB	
Current		8		mA	
IIP3		7		dBm	
Gain Flatness	-0.5		+0.5	dB	
Input Return Loss	12	15		dB	
Output Return Loss		9.5		dB	
Maximum Input Power	5			dBm	
Antenna Switch					
RF-to-Control Isolation	50			dB	
RF-to-ANT Isolation	17	20		dB	
RF-to-RF Isolation	18	20		dB	
T/R Switching Time			1	μs	
Logic Level "HIGH" Input Voltage	$V_{CC}-0.3$		$=V_{CC}$	V	
Logic Level "LOW" Input Voltage	0.0		+0.2	V	
Input Source Current at Logic "HIGH"		5	10	uA	
Switch Leakage Current at Logic "LOW"		0.5		uA	

Control Logic

Switch Control Logic	TX_EN	RX_EN	ANT1_EN	ANT2_EN
Tx, Antenna 1	High	Low	High	Low
Tx, Antenna 2	High	Low	Low	High
Rx, Antenna 1	Low	High	High	Low
Rx, Antenna 2	Low	High	Low	High
All Off	Low	Low	Low	Low

Pin	Function	Description
1	LNA_VCC	Voltage supply for the LNA.
2	RX_EN	Enable voltage for the LNA and receive switch. See logic table for operation.
3	ANT1_EN	Control pin for Antenna 1 switch. See logic table for operation.
4	ANT2_EN	Control pin for Antenna 2 switch. See logic table for operation.
5	GND	Ground.
6	ANT2	This is a common port (antenna). It is matched to 50Ω and DC block is provided internally.
7	GND	Ground.
8	ANT1	This is a common port (antenna). It is matched to 50Ω and DC block is provided internally.
9	GND	Ground.
10	VBAT	Voltage supply for PA 2nd stage. An external 1uF capacitor might be needed for low frequency decoupling.
11	N/C	No connect.
12	VBAT	Voltage supply for PA 1st stage. An external 1uF capacitor might be needed for low frequency decoupling.
13	VBAT	Voltage supply (control circuitry). An external 1uF capacitor might be needed for low frequency decoupling.
14	N/C	No Connect.
15	GND	Ground.
16	GND	Ground.
17	GND	Ground.
18	RF_COM	Bi-directional transmit/receive port for interfacing to TXVR SOIC. It is matched to 50Ω and DC block is provided internally.
19	GND	Ground.
20	TX_EN	Enable voltage for the PA and transmit switch. See logic table for operation.

Package Drawing

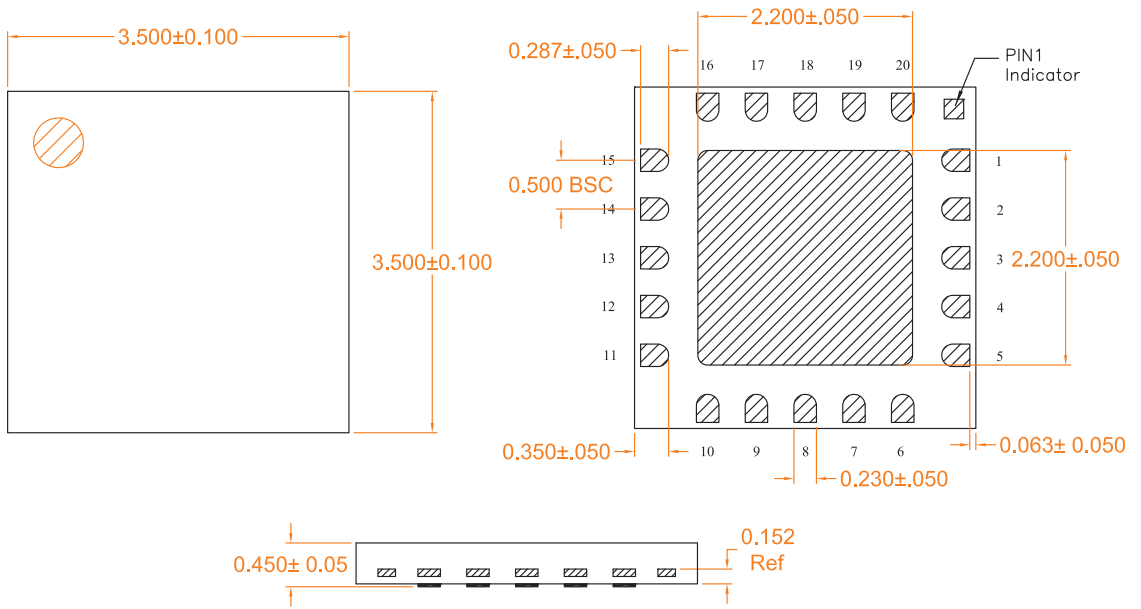

Evaluation Board Schematic

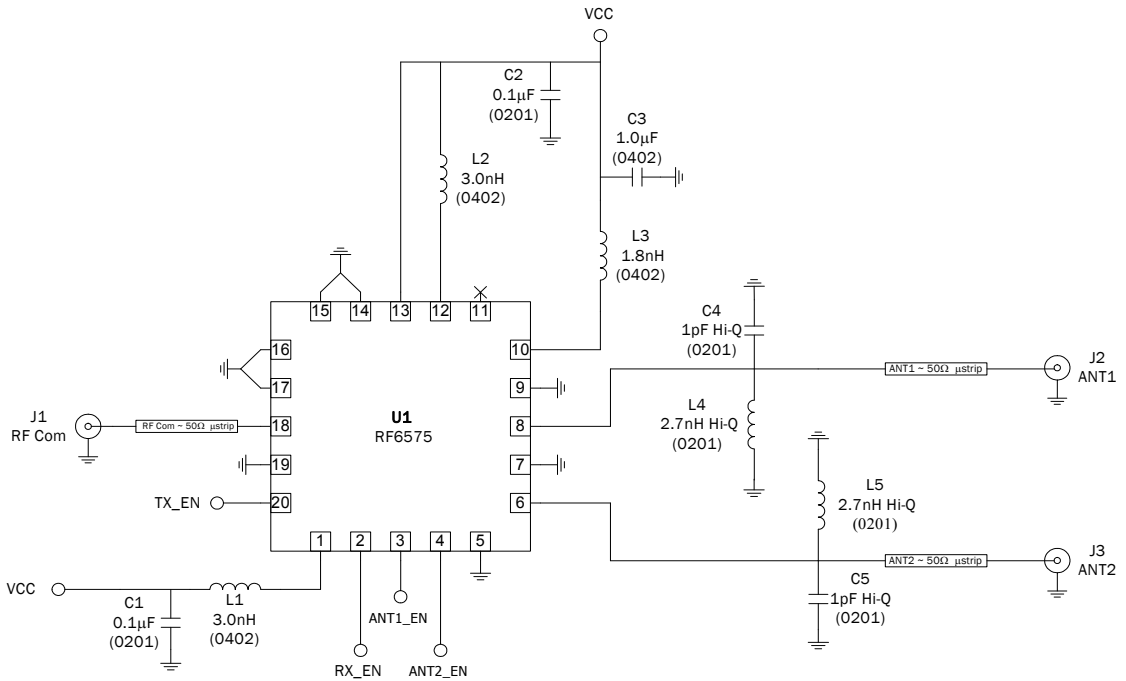

PCB Design Requirements

PCB Surface Finish

The PCB surface finish used for RFMD's qualification process is electroless nickel, immersion gold. Typical thickness is 3µinch to 8µinch gold over 180µinch nickel.

PCB Land Pattern Recommendation

PCB land patterns for RFMD components are based on IPC-7351 standards and RFMD empirical data. The pad pattern shown has been developed and tested for optimized assembly at RFMD. The PCB land pattern has been developed to accommodate lead and package tolerances. Since surface mount processes vary from company to company, careful process development is recommended.

PCB Metal Land and Solder Mask Pattern

A = 0.250 x 0.290 (mm) Typ Rounded Rectangle 50%
 B = 0.290 x 0.250 (mm) Typ Rounded Rectangle 50%
 C = 2.200 (mm) Sq Rounded Rectangle 5%

A = 0.390 x 0.430 (mm) Typ Rounded Rectangle 50%
 B = 0.430 x 0.390 (mm) Typ Rounded Rectangle 50%
 C = 2.340 (mm) Sq Rounded Rectangle 5%

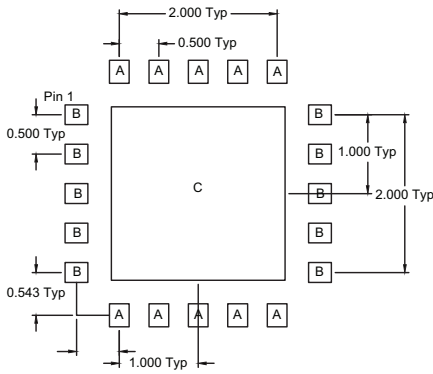

PCB METAL LAND PATTERN

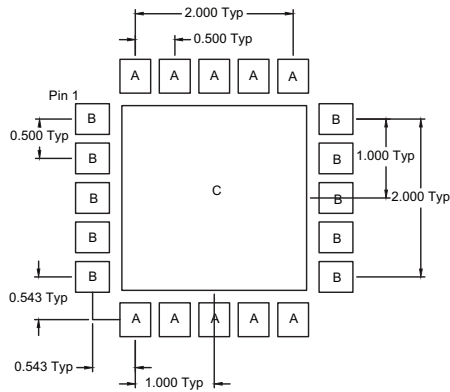

PCB SOLDER MASK PATTERN

A = 0.225 x 0.261 (mm) Typ Rounded Rectangle 10%
 B = 0.261 x 0.225 (mm) Typ Rounded Rectangle 10%
 C = 0.900 (mm) Sq Typ Rounded Rectangle 10%

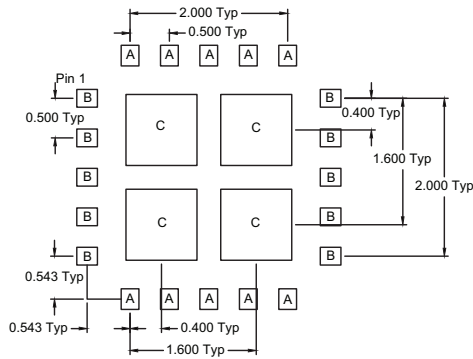

PCB STENCIL PATTERN

Thermal vias for center slug "C" should be incorporated into the PCB design. The number and size of thermal vias will depend on the application, the power dissipation, and this electrical requirements. Example of the number and size of vias can be found on the RFMD evaluation board layout

