



Package: QFN, 10-Pin, 1.75mm x 1.75mm x 0.5mm



Features

- Low Switch Control Voltage 1.5V Minimum
- Low Insertion Loss 0.8dB

Applications

- IEEE802.11b/g/n WiFi Applications
- WiFi/Bluetooth® Combination Devices
- Mobile Devices
- Tablets
- Consumer Electronics
- Gaming
- Netbooks and Notebooks
- TV, Monitors, and Video

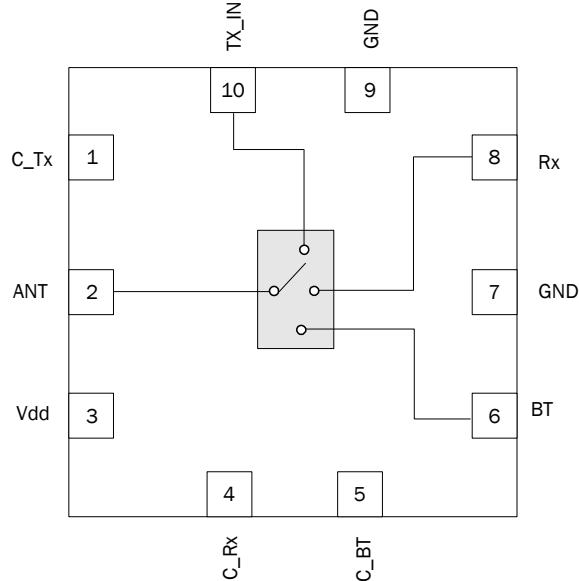

Functional Block Diagram

Product Description

The RF5840 is a SP3T switch designed for WiFi and Bluetooth® applications in the 2.4GHz to 2.5GHz ISM band. The RF5840 is capable of switching between WiFi Rx/Tx and Bluetooth Rx/Tx operations. This switch can also be placed in WiFi and Bluetooth receive modes simultaneously with a slight increase in insertion loss. The RF5840 is provided in a QFN, 10-pin, 1.75mm x 1.75mm x 0.5mm Pb-Free package. This device meets or exceeds the RF switch needs of IEEE802.11b/g/n RF systems.

Ordering Information

RF5840SB	Standard 5-Piece Bag
RF5840	Standard 25-Piece Bag
RF5840SR	Standard 100-Piece Bag
RF5840TR7	Standard 2500-Piece Reel (7")
RF5840PCBK-410	Fully Assembled Evaluation Board

Optimum Technology Matching® Applied

- | | | | |
|--------------------------------------|--------------------------------------|--|------------------------------------|
| <input type="checkbox"/> GaAs HBT | <input type="checkbox"/> SiGe BiCMOS | <input checked="" type="checkbox"/> GaAs pHEMT | <input type="checkbox"/> GaN HEMT |
| <input type="checkbox"/> GaAs MESFET | <input type="checkbox"/> Si BiCMOS | <input type="checkbox"/> Si CMOS | <input type="checkbox"/> BiFET HBT |
| <input type="checkbox"/> InGaP HBT | <input type="checkbox"/> SiGe HBT | <input type="checkbox"/> Si BJT | <input type="checkbox"/> LDMOS |

RF MICRO DEVICES®, RFMD®, Optimum Technology Matching®, Enabling Wireless Connectivity™, PowerStar®, POLARIS™ TOTAL RADIO™ and UltimateBlue™ are trademarks of RFMD, LLC. BLUETOOTH is a trademark owned by Bluetooth SIG, Inc., U.S.A. and licensed for use by RFMD. All other trade names, trademarks and registered trademarks are the property of their respective owners. ©2006, RF Micro Devices, Inc.

Absolute Maximum Ratings

Parameter	Rating	Unit
Supply Voltage	5	V
Ruggedness Output VSWR	10:1	
Stability Output VSWR	5:1	
ESD Human Body Model	150	V
ESD Device Model	500	V
Operating Temperature Range	-40 to +85	°C
Storage Temperature	-40 to +150	°C
Moisture Sensitivity Level	MSL2	



Caution! ESD sensitive device.

Exceeding any one or a combination of the Absolute Maximum Rating conditions may cause permanent damage to the device. Extended application of Absolute Maximum Rating conditions to the device may reduce device reliability. Specified typical performance or functional operation of the device under Absolute Maximum Rating conditions is not implied.

The information in this publication is believed to be accurate and reliable. However, no responsibility is assumed by RF Micro Devices, Inc. ("RFMD") for its use, nor for any infringement of patents, or other rights of third parties, resulting from its use. No license is granted by implication or otherwise under any patent or patent rights of RFMD. RFMD reserves the right to change component circuitry, recommended application circuitry and specifications at any time without prior notice.



RFMD Green: RoHS compliant per EU Directive 2002/95/EC, halogen free per IEC 61249-2-21, < 1000ppm each of antimony trioxide in polymeric materials and red phosphorus as a flame retardant, and <2% antimony in solder.

Parameter	Specification			Unit	Condition
	Min.	Typ.	Max.		
2.4GHz to 2.5GHz Switch Transmit and Receive Parameters					Unless otherwise noted the following conditions apply: Control voltage = 1.8V, Temp = -40 °C to +85 °C, over frequency range, and over V _{DD} range
Frequency	2.4		2.5	GHz	
Insertion Loss		0.8	2.0	dB	All ports
Insertion Loss (Simultaneous Mode)		3.8	4.2	dB	See logic table
Passband Ripple	-0.2		+0.2	dB	
Input/Output Power	18	22		dBm	EVM < 1%; V _{CONTROL} = 1.8V V _{DD} = 1.8V
P1dB	20	25		dBm	Tx and Rx Ports, V _{CONTROL} = 1.8V V _{DD} = 1.8V
	20	25		dBm	BT port, V _{CONTROL} 1.8V, V _{DD} - 1.8V
Input Return Loss	15	18		dB	
Output Return Loss	15	18		dB	
Current Consumption		1	10	µA	Switch operating current
Port Impedance					All ports
Input		50		Ω	Receive
Output		50		Ω	Transmit
Isolation	20	25		dB	All RF Ports
Voltage Supply (V _{DD})					
High	1.7	1.8	4.2	V	See note1
Low		0	0.2	V	
Voltage Supply Leakage Current			5	µA	V _{DD} = 4.2V; Control voltage LOW; No RF
Switch Control Voltage					C_TX, C_RX, and C_BT
Low		0	0.2	V	
High	1.5		4.2	V	see Note
Switch Control Speed		85	150	nsec	

Note: The control voltage for C_RX, C_TX, and C_BT need to be equal or within 0.2V of V_{DD} for proper operation. The switch also functions with V_{DD} floating but will have lower power handling capability.

Pin Names and Description

Pin	Name	Description
1	C_TX	Control pin for Tx to ANT.
2	ANT	Antenna port. Internally matched to 50Ω. External DC block required.
3	VDD	Switch supply voltage. It is recommended to use a low frequency bypass capacitor to filter out noise.
4	C_RX	Control pin for ANT to Rx.
5	C_BT	Control pin for ANT to BT.
6	BT	Bluetooth port. Internally matched to 50Ω. External DC block required.
7	GND	Ground connection. Ground as close as possible to the package pin.
8	RX_OUT	Receiver output port. Internally matched to 50Ω. External DC block.
9	GND	Ground connection. Ground as close as possible to the package pin.
10	TX_IN	Transmit input port. Internally matched to 50Ω. External DC block required.

Switch Control Logic

Mode	C_TX	C_RX	C_BT	VDD	Comments
Tx-ANT	H	L	L	H	Tx Port to ANT Port
Rx-ANT	L	H	L	H	Rx Port to ANT Port
BT-ANT	L	L	H	H	BT Port to ANT Port
Rx/BT-ANT*	L	H	H	H	Simultaneous Rx and BT to ANT Port
Off	L	L	L	L	Off Mode

*The SP3T Switch can be placed in simultaneous receive WiFi Bluetooth modes with increased insertion loss.

Pin Out

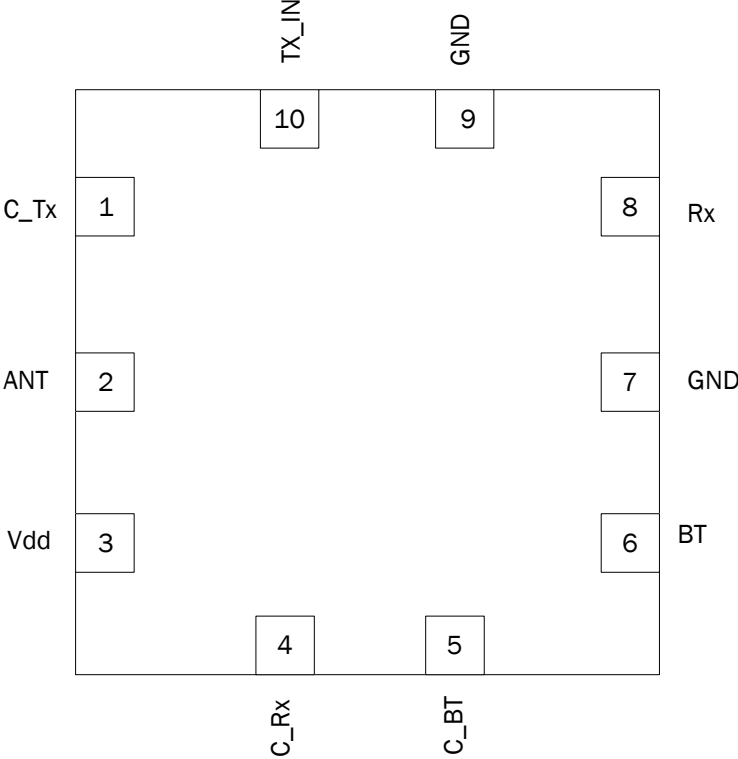

Application Schematic

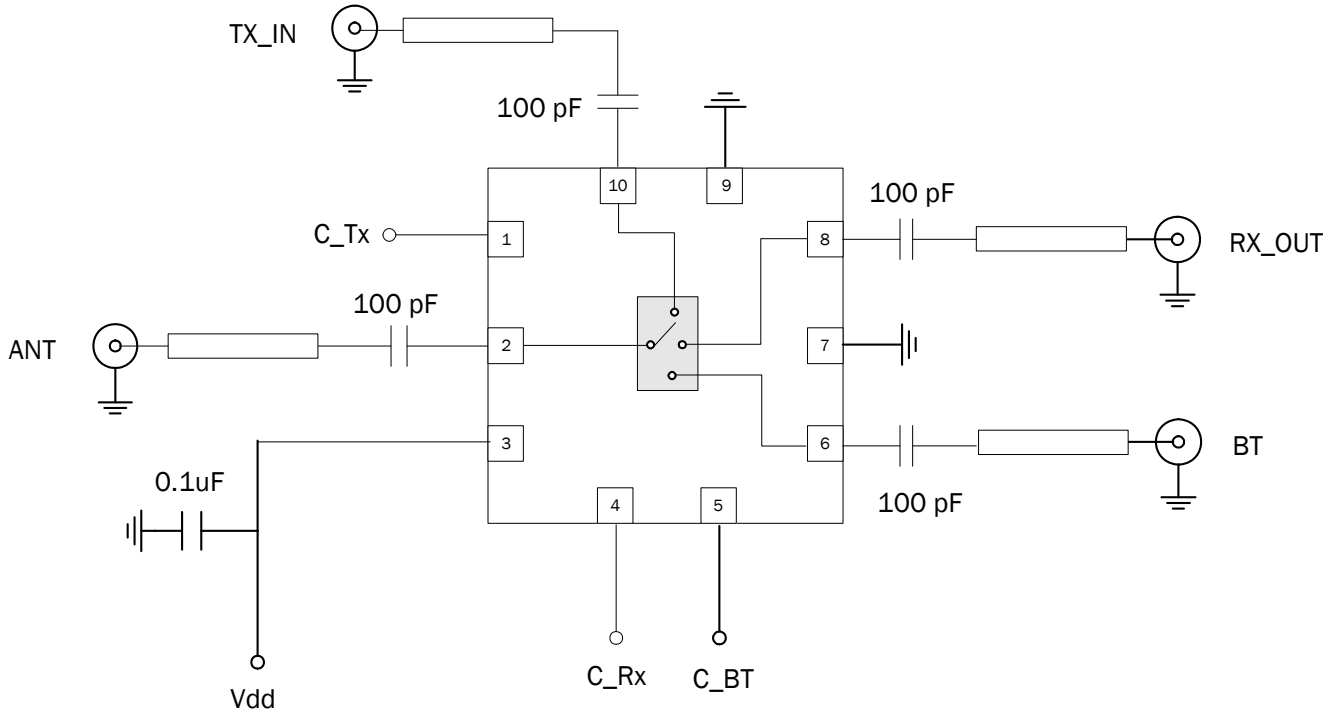

Package Drawing

QFN, 10-Pin, 1.75mm x 1.75mm x 0.5mm

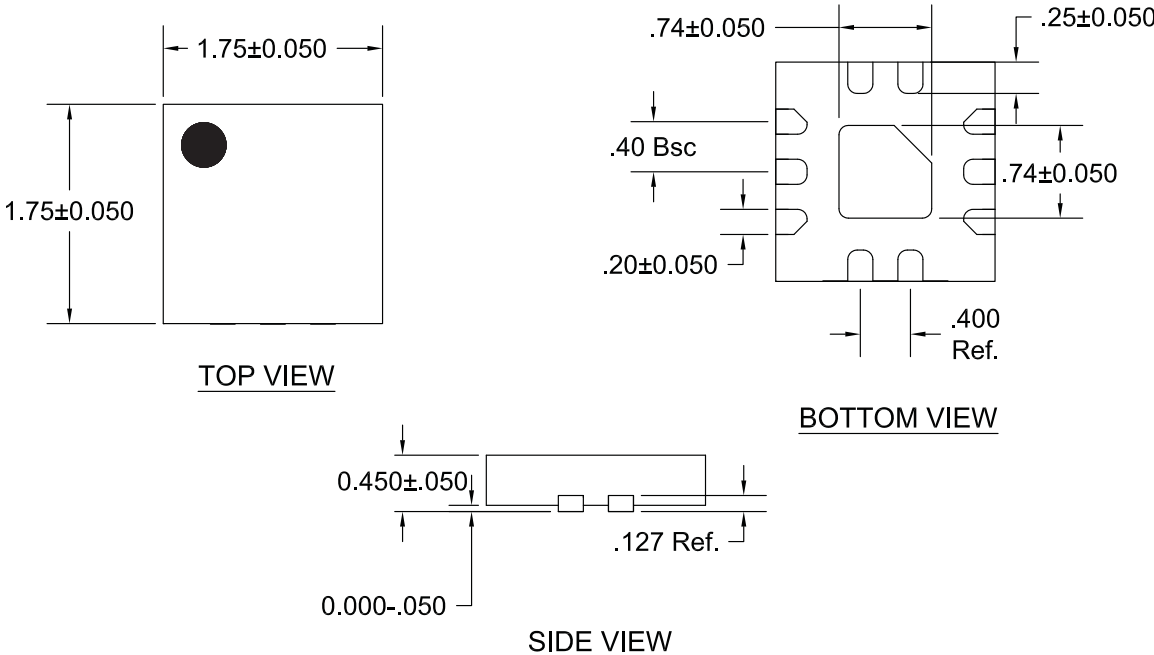

- Notes:
- 1) Pin 1 Shaded Area
 - 2) Chamfered area is Pin 1

PCB Patterns

A = 0.200x 0.378 (mm) Typ
 B = 0.378 x 0.200 (mm) Typ
 C = 0.740 (mm) Sq

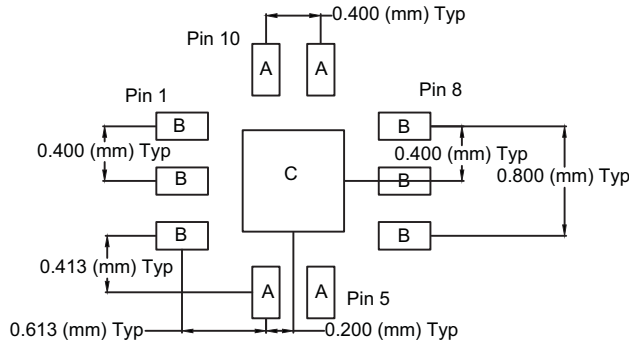

PCB METAL LAND PATTERN

A = 0.300 x 0.478 (mm) Typ
 B = 0.478 x 0.300 (mm) Typ
 C = 0.840 (mm) Sq

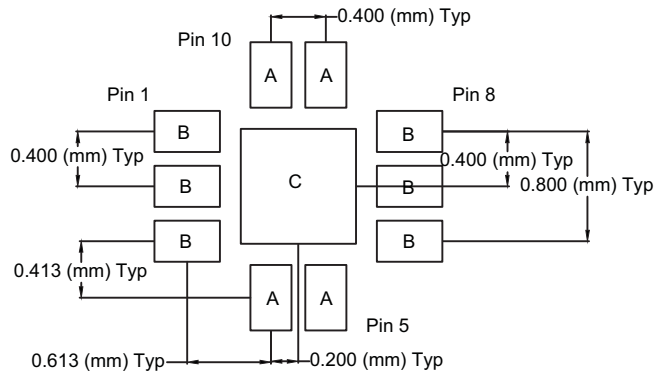

PCB SOLDER MASK PATTERN

A = 0.180 x 0.340 (mm) Typ
 B = 0.340 x 0.180 (mm) Typ
 C = 0.666 (mm) Sq

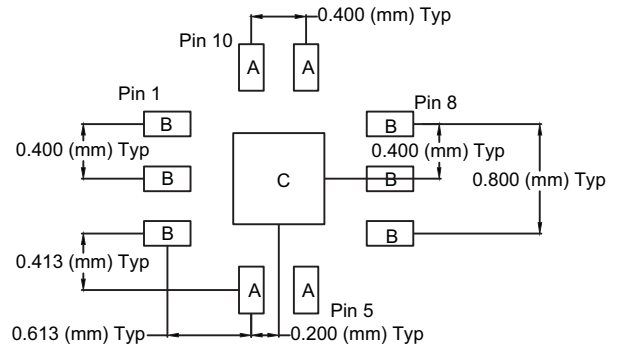

PCB STENCIL PATTERN

RF5840 EVALUATION BOARD

1.5in. x 1.5in. x 0.034in. +/-10%

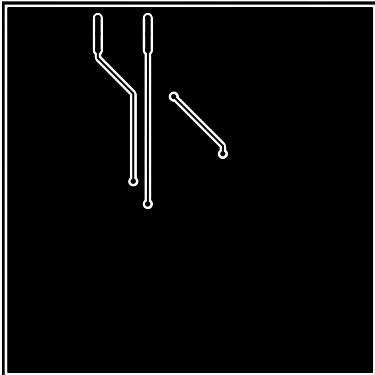
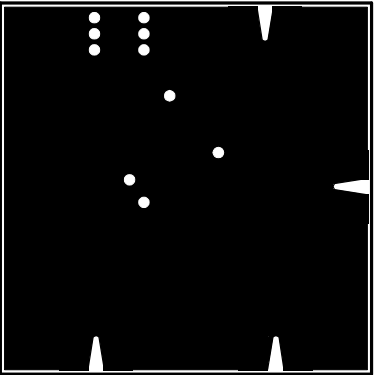
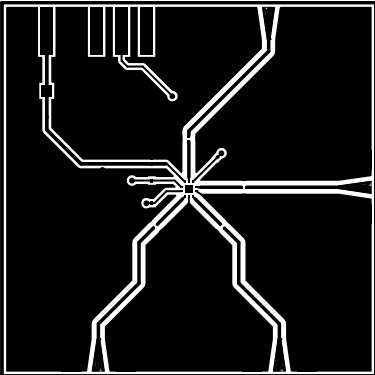

RF5840 Performance Plots

