



Package: QFN, 12-Pin, 2mm x 2mm x 0.55mm



**Features**

- 5MHz to 6000MHz Operation
- 50Ω or 75Ω Applications
- Low Insertion Loss: 0.30dB at 1980MHz
- High Isolation: 37dB at 2GHz
- High IP3: >75dBm at 2GHz
- Compatible with Low Voltage Logic ( $V_{HIGH}$  Minimum = 1.3V)
- No External DC Blocking Capacitors Required on RF Paths Unless DC is Applied Externally
- 2000V HBM ESD Rating on All Ports
- CTB/CSO: >100dBc (41dBmV/ch., 137 Channels)

**Applications**

- LTE, WCDMA, GSM
- CATV, SATV Applications
- Post PA Switching
- General Purpose Switching Applications

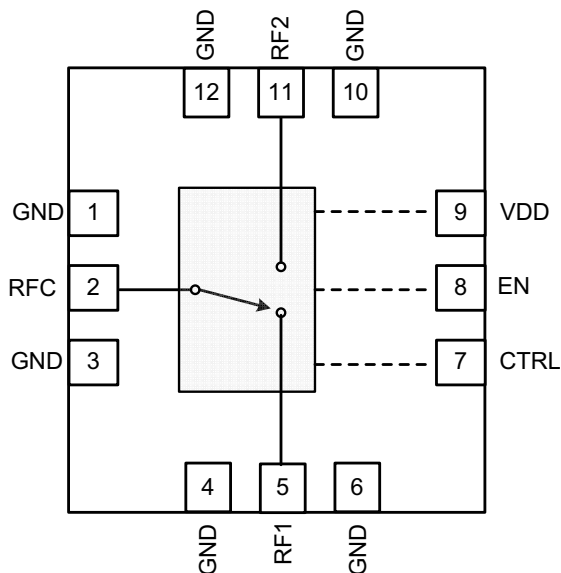

Functional Block Diagram

**Product Description**

The RFSW1012 is a single-pole double-throw (SPDT) switch designed for applications requiring very low insertion loss and high power handling capability. The excellent linearity performance of the RFSW1012 makes it ideal for use in LTE, WCDMA, and CDMA applications. This switch is ideally suited for use in CATV and SATV applications. The RFSW1012 is packaged in a compact 2mm x 2mm x 0.55mm, 12-pin, QFN package.

**Ordering Information**

RFSW1012SQ	25-Piece sample bag
RFSW1012SR	7" Sample reel with 100 pieces
RFSW1012TR13	13" Reel with 2500 pieces
RFSW1012PCK-411	50Ω PCBA with 5-piece sample bag
RFSW1012PCK-410	75Ω PCBA with 5-piece sample bag

**Optimum Technology Matching® Applied**

- |                                      |                                      |   |                                    |
|--------------------------------------|--------------------------------------|---|------------------------------------|
| <input type="checkbox"/> GaAs HBT    | <input type="checkbox"/> SiGe BiCMOS | <input type="checkbox"/> GaAs pHEMT         | <input type="checkbox"/> GaN HEMT  |
| <input type="checkbox"/> GaAs MESFET | <input type="checkbox"/> Si BiCMOS   | <input checked="" type="checkbox"/> Si CMOS | <input type="checkbox"/> BiFET HBT |
| <input type="checkbox"/> InGaP HBT   | <input type="checkbox"/> SiGe HBT    | <input type="checkbox"/> Si BJT             | <input type="checkbox"/> SOI       |

RF MICRO DEVICES®, RFMD®, Optimum Technology Matching®, Enabling Wireless Connectivity™, PowerStar®, POLARIS™ TOTAL RADIO™ and UltimateBlue™ are trademarks of RFMD, LLC. BLUETOOTH is a trademark owned by Bluetooth SIG, Inc., U.S.A. and licensed for use by RFMD. All other trade names, trademarks and registered trademarks are the property of their respective owners. ©2012, RF Micro Devices, Inc.

## Absolute Maximum Ratings

Parameter	Rating	Unit
Maximum $V_{DD}$	6.0	V
Maximum EN	3.0	V
Maximum CTRL	3.0	V
Hot-Switching Max Input Power (50Ω load)	20	dBm
Max Input Power	31dBm: 5MHz to 25MHz, 50Ω load 34dBm: 25MHz to 500MHz, 50Ω load 37dBm: >500MHz, 50Ω load 36dBm: >500MHz, 6:1 VSWR	dBm
Operating Temperature ( $T_{CASE}$ )	-40 to +85	°C
Storage Temperature	-40 to +150	°C
ESD Rating (HBM)	Class 2	
Moisture Sensitivity Level	MSL-2	



**Caution!** ESD sensitive device.

Exceeding any one or a combination of the Absolute Maximum Rating conditions may cause permanent damage to the device. Extended application of Absolute Maximum Rating conditions to the device may reduce device reliability. Specified typical performance or functional operation of the device under Absolute Maximum Rating conditions is not implied.

The information in this publication is believed to be accurate and reliable. However, no responsibility is assumed by RF Micro Devices, Inc. ("RFMD") for its use, nor for any infringement of patents, or other rights of third parties, resulting from its use. No license is granted by implication or otherwise under any patent or patent rights of RFMD. RFMD reserves the right to change component circuitry, recommended application circuitry and specifications at any time without prior notice.



RFMD Green: RoHS compliant per EU Directive 2002/95/EC, halogen free per IEC 61249-2-21, < 1000ppm each of antimony trioxide in polymeric materials and red phosphorus as a flame retardant, and <2% antimony in solder.

Parameter	Specification			Unit	Condition
	Min.	Typ.	Max.		
<b>50Ω Performance Using SW1012-411(A) EVB</b>					Nominal Test Conditions Unless Otherwise Stated: $V_{DD} = 3V$ , $T = 25^{\circ}C$ , All RF ports terminated in 50Ω
Operational Frequency Range	5		6000	MHz	
Insertion Loss (RFC to RF1/RF2)		0.25	0.40	dB	915MHz
		0.30	0.45	dB	1980MHz
		0.40		dB	2650MHz
		0.45		dB	5850MHz
Isolation (RFC to RF1/RF2)	38	45		dB	915MHz
	33	37		dB	1980MHz
		33		dB	2650MHz
		21		dB	5850MHz
Isolation (RF1 to RF2)		42		dB	915MHz
		35		dB	1980MHz
		32		dB	2650MHz
		21		dB	5850MHz
Return Loss (On-State)		>15		dB	5MHz to 6GHz
Input IP3		75		dBm	2.2GHz, 24dBm per tone, 1MHz spacing
Input IP2		129		dBm	Tone 1: 836.5MHz at +26dBm; Tone 2: 1718MHz at -20dBm; Rx Freq: 881.5MHz
		129		dBm	Tone 1: 1880MHz at +26dBm; Tone 2: 3840MHz at -20dBm; Rx Freq: 1960MHz
Spurious Output		<-105		dBm	Freq >5MHz, all ports terminated, no RF Inputs
		<-100		dBm	Freq <5MHz, all ports terminated, no RF Inputs
900MHz Second Harmonic		-95	-75	dBc	$P_{IN} = 35dBm$
900MHz Third Harmonic		-90	-75	dBc	
1800MHz Second Harmonic		-95	-75	dBc	$P_{IN} = 33dBm$
1800MHz Third Harmonic		-90	-75	dBc	
Max Operational Input Power			30	dBm	5MHz to 25MHz, 50Ω load
			33	dBm	25MHz to 500MHz, 50Ω load
			36	dBm	>500MHz, 50Ω load

Parameter	Specification			Unit	Condition
	Min.	Typ.	Max.		
<b>75Ω Performance Using SW1012-410(A) EVB</b>					Nominal Test Conditions Unless Otherwise Stated: V <sub>DD</sub> = 3V, T = 25 °C, All RF ports terminated in 75Ω
Operational Frequency Range	5		2500	MHz	
Insertion Loss (RFC to RF1/RF2)		0.15		dB	5MHz
		0.20		dB	200MHz
		0.30	0.45	dB	915MHz
		0.35	0.50	dB	1980MHz
		0.40			2200MHz
Isolation (RFC to RF1/RF2)		70		dB	5MHz
		50		dB	200MHz
		36		dB	915MHz
		28		dB	1980MHz
		26		dB	2200MHz
Isolation (RF1 to RF2)		>70		dB	5MHz
		>70		dB	200MHz
		48		dB	915MHz
		34		dB	1980MHz
		32		dB	2200MHz
Return Loss (On-State)		>15		dB	Freq <1200MHz
		>13		dB	1200MHz < Freq < 2500MHz
CSO		>100		dBc	41dBmV/ch, 137 channels)
CTB		>100		dBc	
XMOD		>90		dBc	
Max Operational Input Power			30	dBm	5MHz to 25MHz, 75Ω load
			33	dBm	25MHz to 500MHz, 75Ω load
			36	dBm	>500MHz, 75Ω load
<b>Power Supply</b>					
Device Voltage, V <sub>DD</sub>	2.7	3	4.6	V	
Leakage Current, I <sub>DD</sub>		100	200	μA	EN = High
		14	20	μA	EN = Low
Control Voltage (EN, CTRL)	1.3	1.8	2.7	V	
		0	0.45	V	
Control Current		2.5	5	μA	CTRL = High, EN = High
		1	3	μA	CTRL = Low, EN = High
Switching Speed (T <sub>ON</sub> , T <sub>OFF</sub> )		2	5	μs	50% Control to 10/90% RF

## Typical Performance: 50Ω Evaluation Board

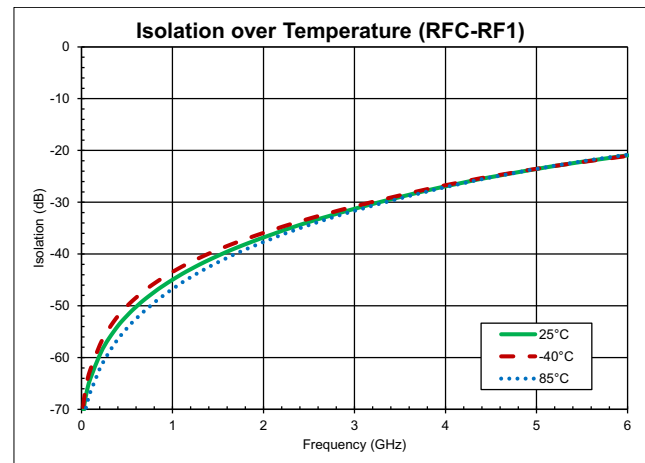
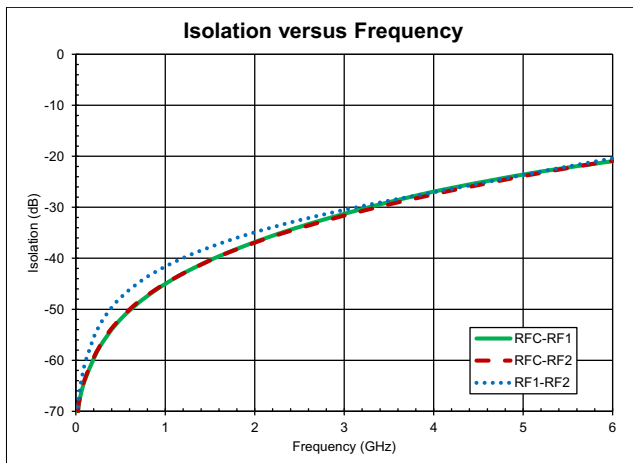
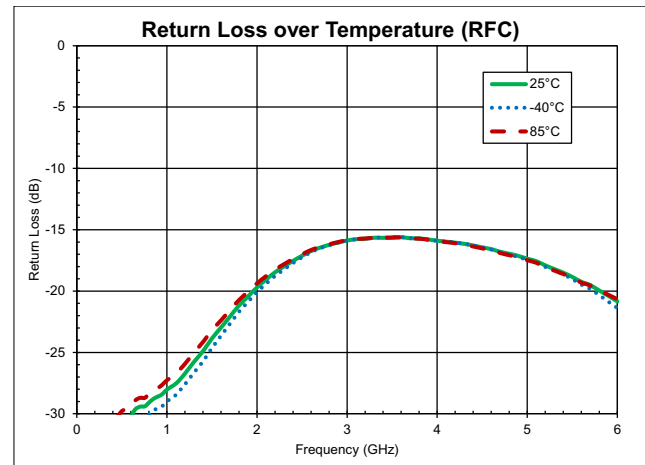
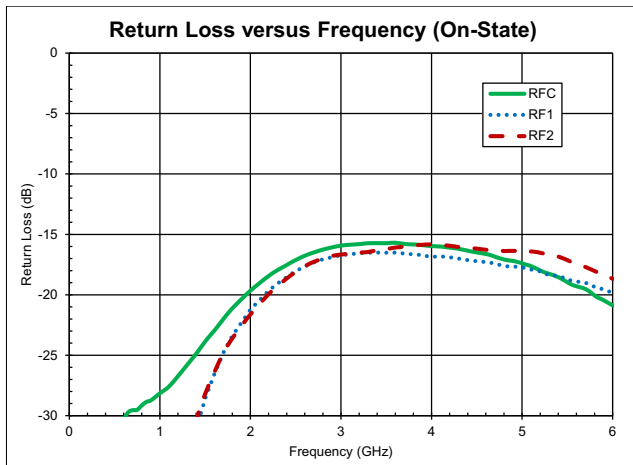
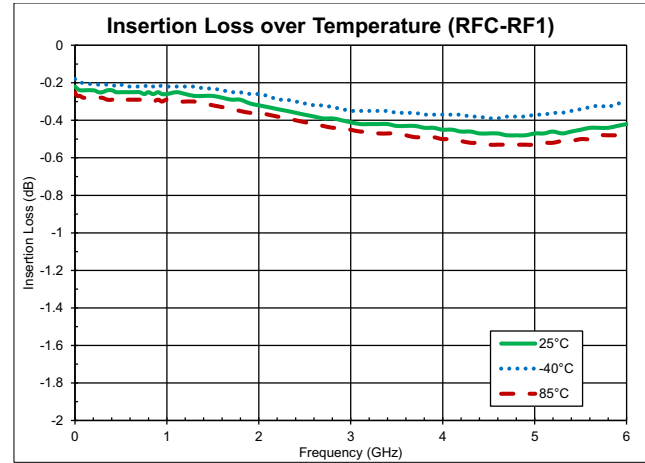
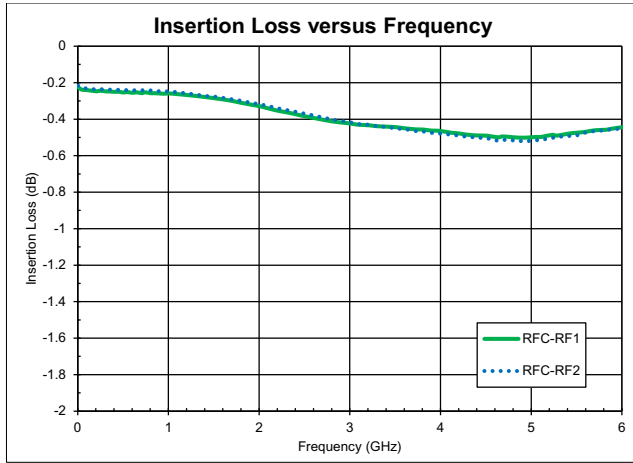

Typical Performance: 50Ω Evaluation Board

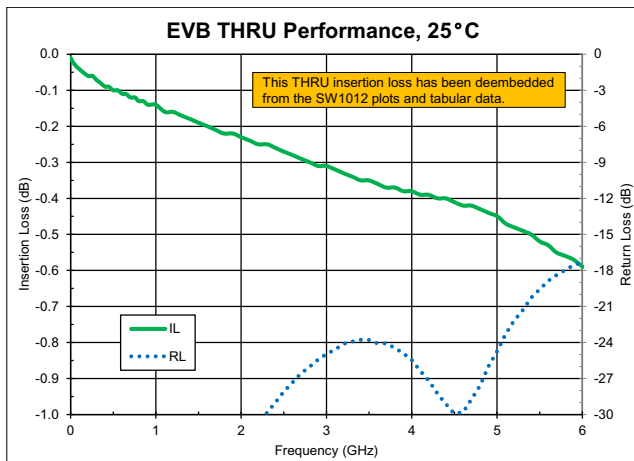
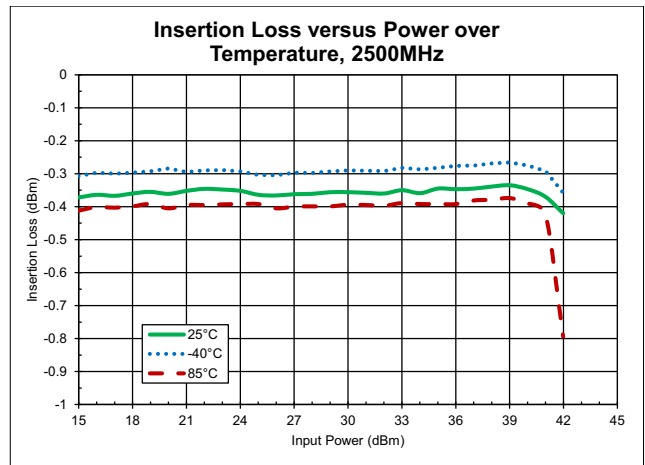
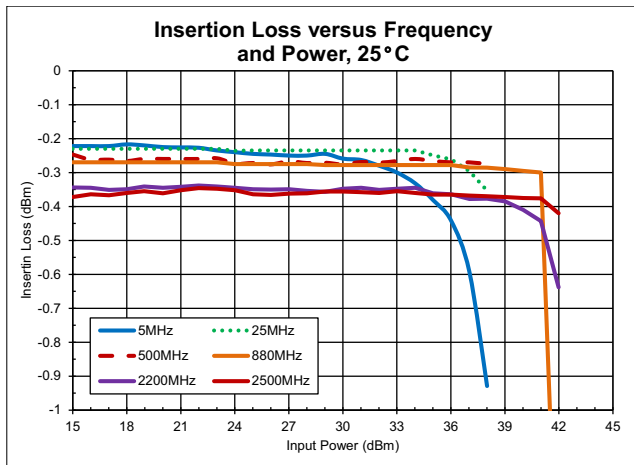
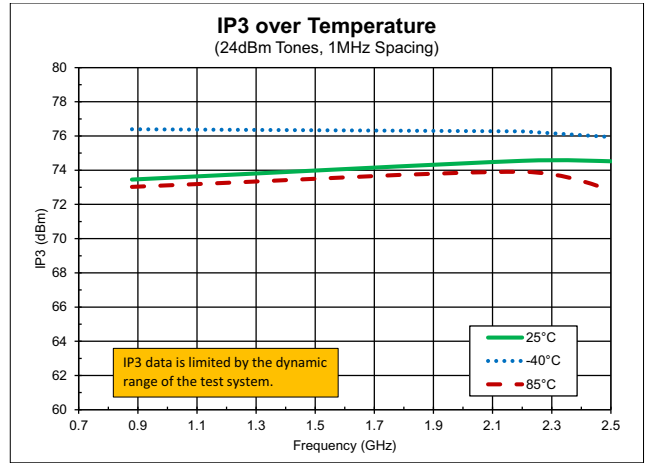
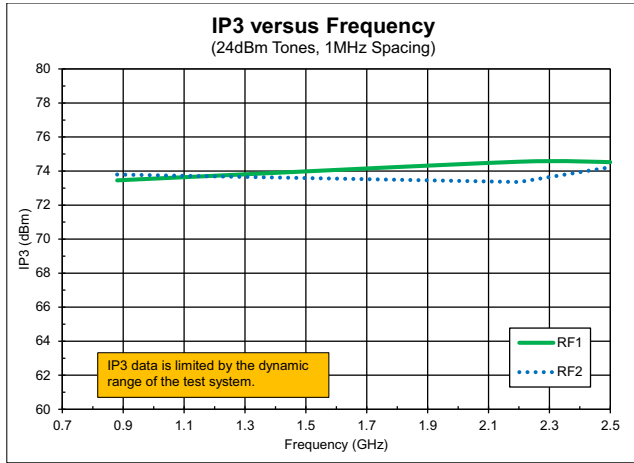

## Typical Performance: 75Ω Evaluation Board

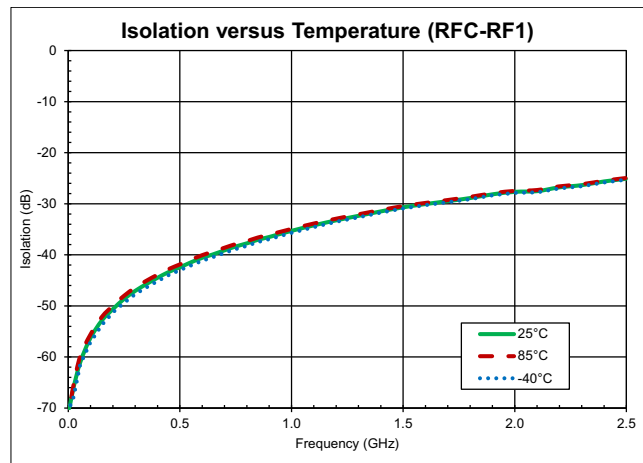
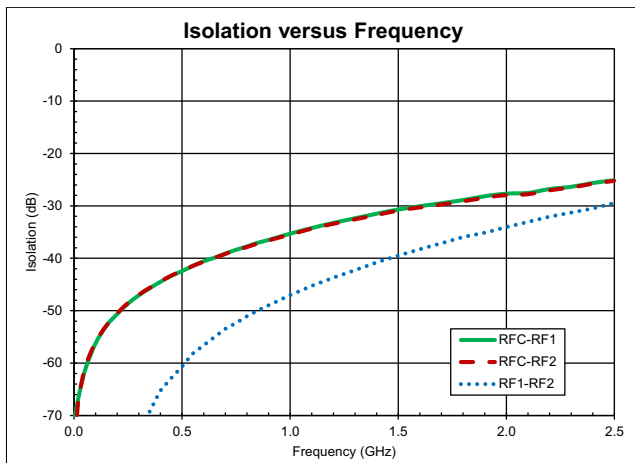
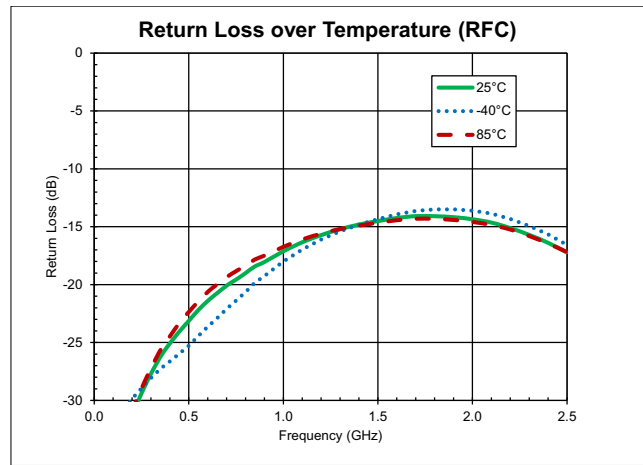
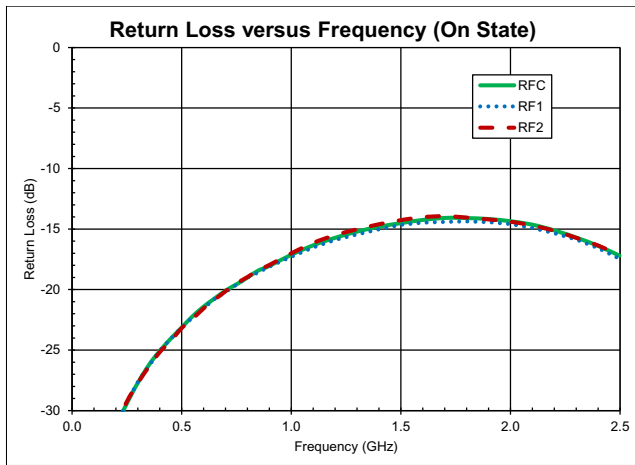
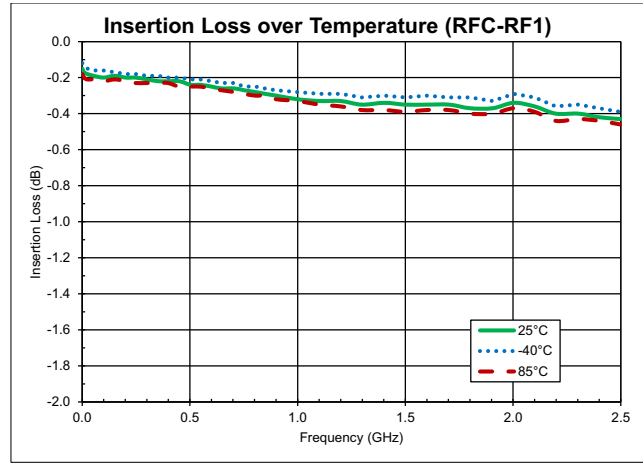
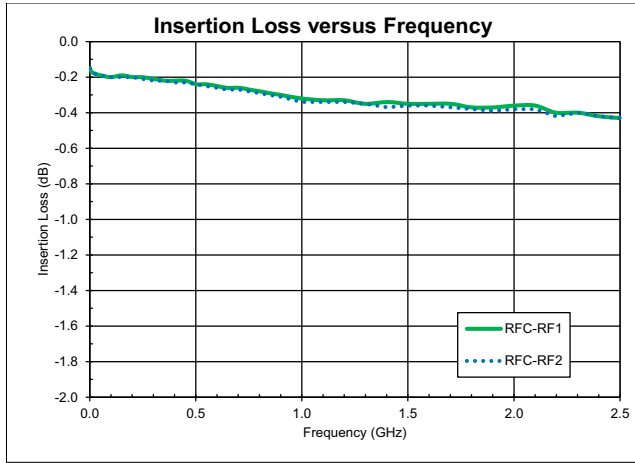

Typical Performance: 75Ω Evaluation Board

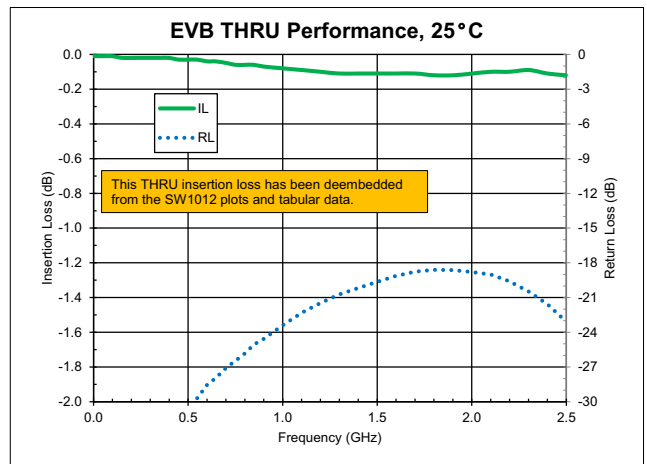
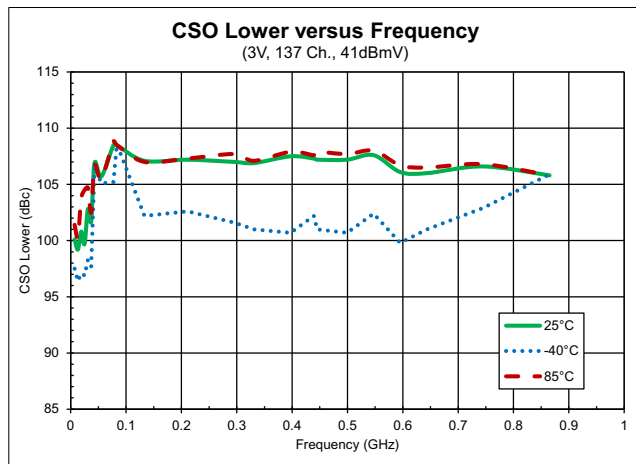
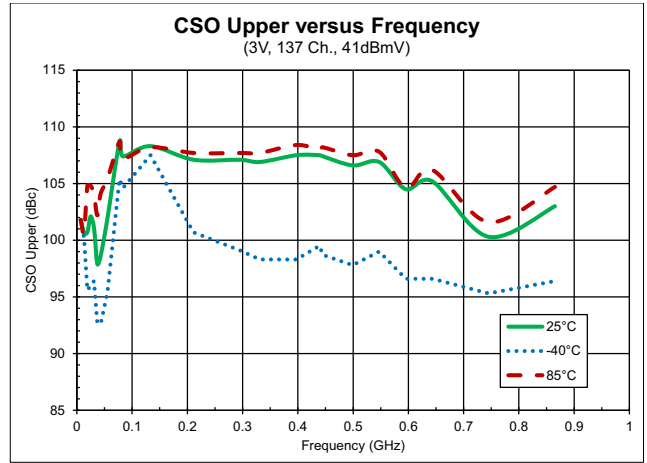
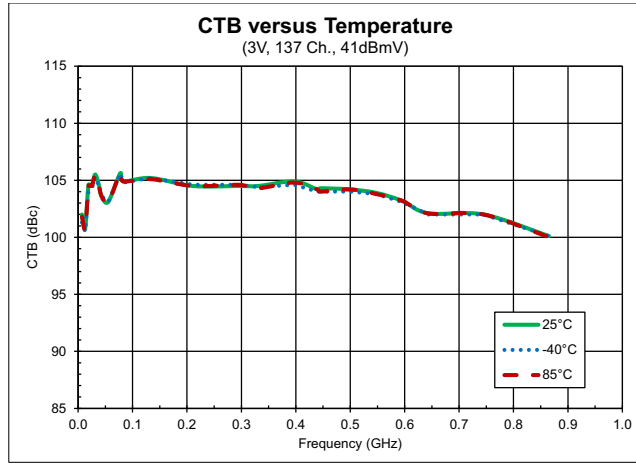

## Evaluation Board Schematic

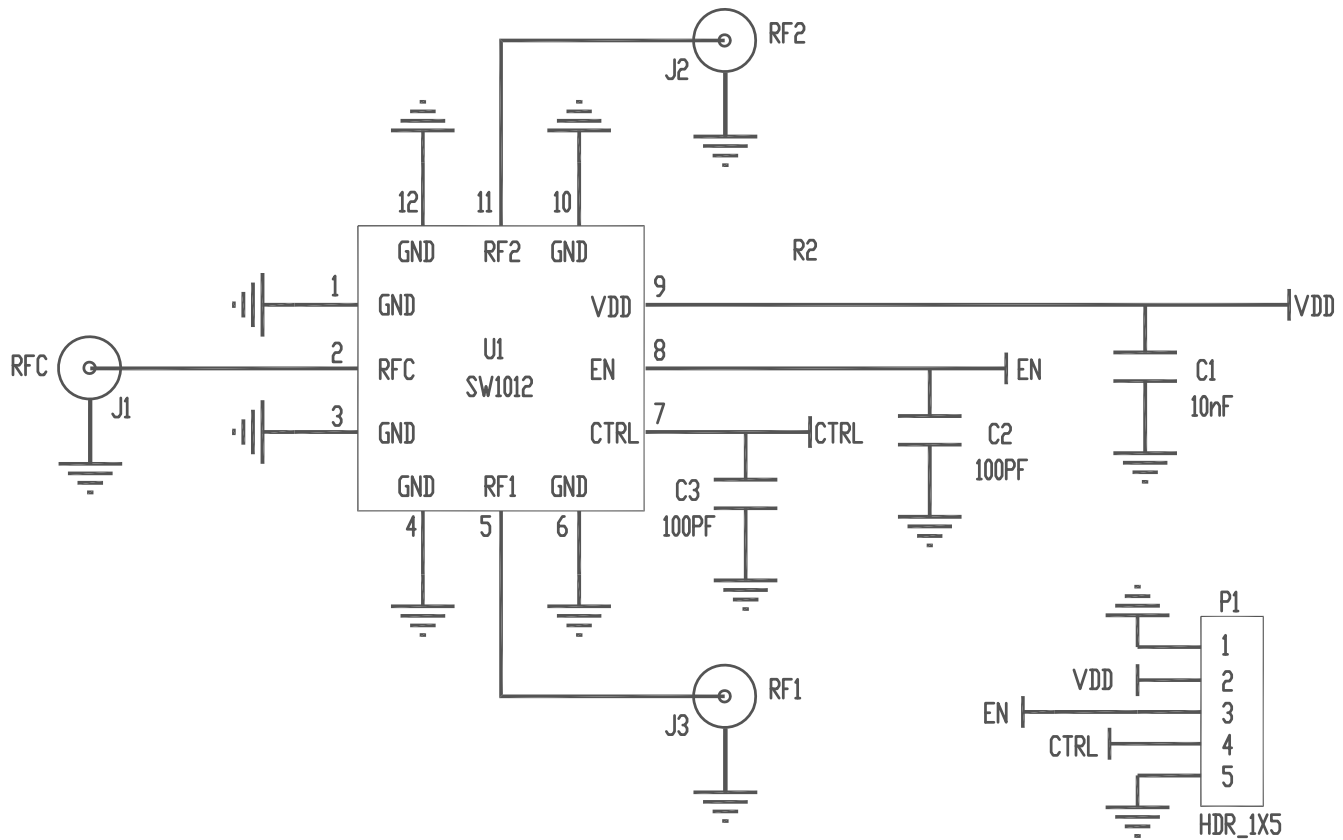

## Evaluation Board Bill of Materials (BOM)

Description	Reference Designator	Manufacturer	Manufacturer's P/N
50Ω PCB, SW1012-411			SW1012-411(A)
CAP, 10000pF, 10%, 25V, X7R, 0402	C1	Murata Electronics	GRM155R71E103KA01D
CAP, 100pF, 5%, 50V, COG, 0402	C2-C3	Taiyo Yuden (USA), Inc.	RM UMK105CG101JV-F
CONN, SMA, END LNCH, MINI, FLT, 0.068"	J1-J3	Emerson Network Power	142-0741-851
CONN, HDR, ST, PLRZD, 5-PIN, 0.100"	P1	ITW Pancon	MPSS100-5-C
SPDT MMIC Switch	U1	RFMD	
For 75Ω applications use the following PCB and RF connector:			
75Ω PCB, SW1012-410			SW1012-410(A)
CONN, F, FEM EDGE MOUNT, 75Ω, 0.068"	J1- J3	Millimeter Wave Technologies	MW-846-C-DD-75



**50Ω Evaluation Board Assembly Drawing**

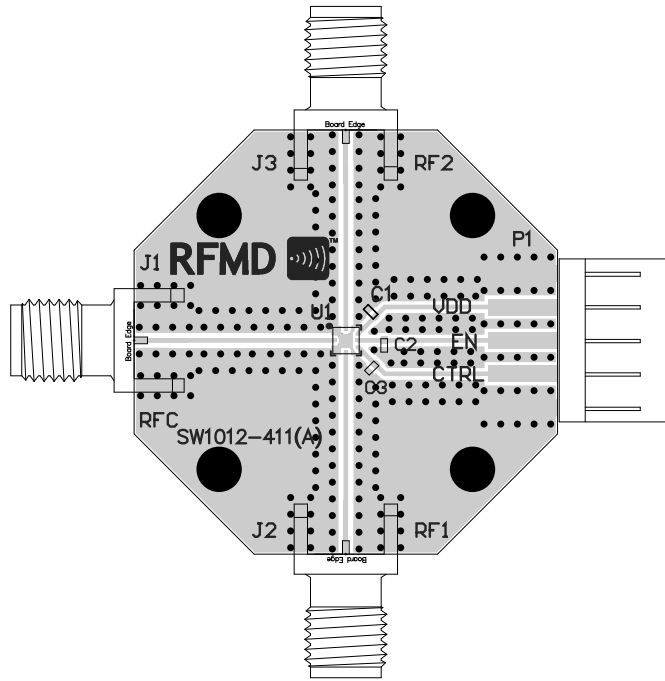

**75Ω Evaluation Board Assembly Drawing**

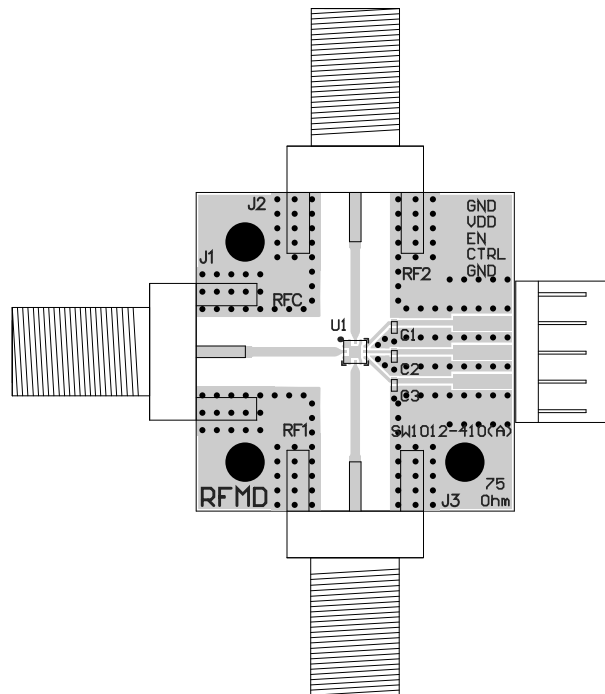

## Control Logic for Valid Operational States

State	V <sub>DD</sub>	CTRL	EN	RF Path
1	2.7V to 4.6V	V <sub>HIGH</sub>	V <sub>HIGH</sub>	ANT-RF2
2	2.7V to 4.6V	V <sub>LOW</sub>	V <sub>HIGH</sub>	ANT-RF1
Shutdown	2.7V to 4.6V	Don't Care	V <sub>LOW</sub>	Shutdown

## Pin Names and Descriptions

Pin	Name	Description
1	GND	No-connect internal, recommend GND at the EVB level.
2	RFC	Single-ended RF port.
3	GND	No-connect internal, recommend GND at the EVB level.
4	GND	Ground.
5	RF1	Single-ended RF port.
6	GND	Ground.
7	CTRL	Switch logic control input.
8	EN	Shutdown logic control input.
9	VDD	Supply voltage.
10	GND	Ground.
11	RF2	Single-ended RF port.
12	GND	Ground.
EPAD	GND	Ground. Must be soldered to EVB GND over one or more vias.

## Pin Out

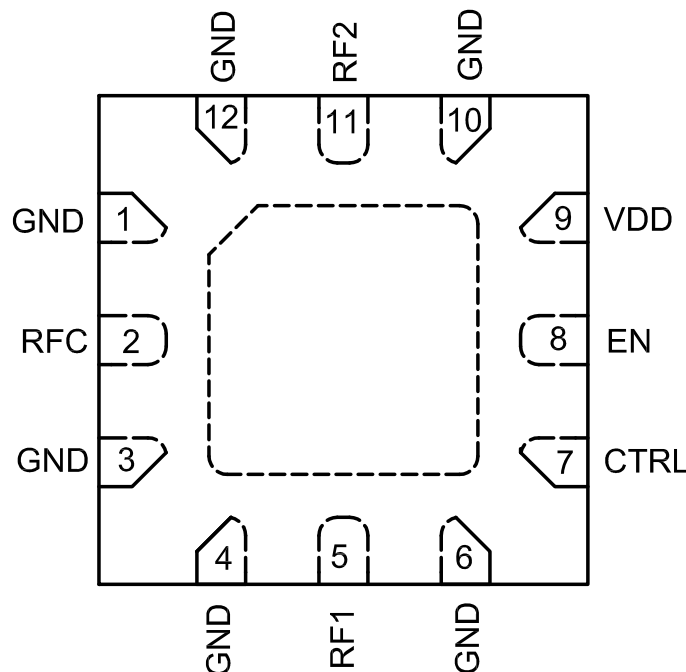

**Package Drawing and Branding Diagram**  
(Dimensions in millimeters)

