



### Features

- High Power and High Efficiency Transmit Module
- Enhanced PowerStar™ Architecture to Facilitate TRP Performance
- GSM850 PAE 34%
- PCS1900 PAE 36%
- GSM850 P<sub>OUT</sub> 33.4dBm
- PCS1900 P<sub>OUT</sub> 31.9dBm
- Integrated Antenna Switch and Harmonic Filtering
- Dedicated RX Ports
- Automatic V<sub>BATT</sub> Tracking Circuit

### Applications

- GSM850/PCS1900 Products
- GPRS Class 10 Compatible
- 3V Dual-Band GSM/GPRS Handsets
- Portable Battery-Powered Equipment

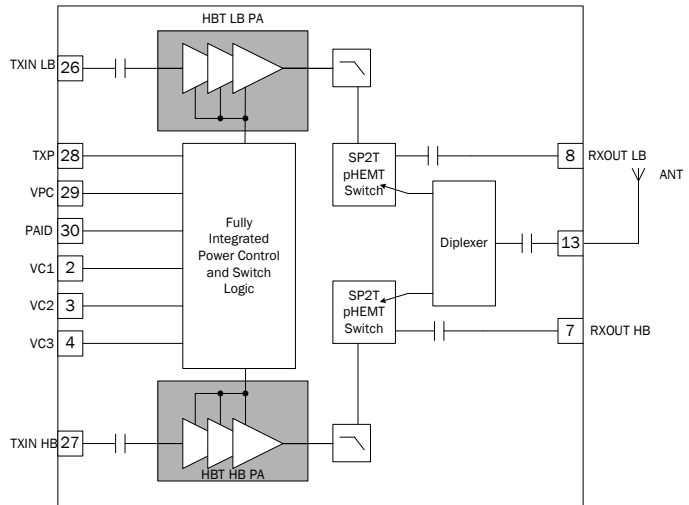

Functional Block Diagram

### Product Description

The RF3285 is a high-power, high-efficiency transmit module containing RFMD's PowerStar™ integrated power control, integrated pHEMT front end antenna switch, and harmonic filtering functionality. These features combine to provide for best-in-class harmonic emission control and RX and TX insertion loss. The device is self-contained with 50Ω input and output terminals with no matching components required. The integrated power control function based on RFMD's patented PowerStar™ control eliminates the need for directional couplers, detector diodes, power control ASICs, and other power control circuitry. This allows the module to be driven directly from the DAC output. The device is designed for use as the final portion of the transmit chain in dual-band applications utilizing GSM850/PCS1900 and eliminates the need for PA-to-antenna switch module matching. On-board power control provides over 70dB control range. The integrated antenna switch allows true dual-band TX and RX functionality. This device also features RFMD's latest integrated power flattening circuit which significantly reduces current and power variation into load mismatch.

### Ordering Information

RF3285	Dual-Band GSM850/PCS1900 Transmit Module
RF3285SB	Transmit Module 5-Piece Sample Pack
RF3285PCBA-41X	Fully Assembled Evaluation Board

### Optimum Technology Matching® Applied

- |  |                                      |  |                                   |
|--|--------------------------------------|--|-----------------------------------|
| <input checked="" type="checkbox"/> GaAs HBT | <input type="checkbox"/> SiGe BiCMOS | <input checked="" type="checkbox"/> GaAs pHEMT | <input type="checkbox"/> GaN HEMT |
| <input type="checkbox"/> GaAs MESFET         | <input type="checkbox"/> Si BiCMOS   | <input checked="" type="checkbox"/> Si CMOS    | <input type="checkbox"/> RF MEMS  |
| <input type="checkbox"/> InGaP HBT           | <input type="checkbox"/> SiGe HBT    | <input type="checkbox"/> Si BJT                | <input type="checkbox"/> LDMOS    |

## Absolute Maximum Ratings

Parameter	Rating	Unit
Supply Voltage	-0.3 to +6.0	V
Power Control Voltage ( $V_{RAMP}$ )	-0.3 to +2.4	V
Input RF Power	+10	dBm
Max Duty Cycle	25	%
Output Load VSWR	20:1	
Operating Temperature	-30 to +85	°C
Storage Temperature	-55 to +150	°C



**Caution!** ESD sensitive device.

Exceeding any one or a combination of the Absolute Maximum Rating conditions may cause permanent damage to the device. Extended application of Absolute Maximum Rating conditions to the device may reduce device reliability. Specified typical performance or functional operation of the device under Absolute Maximum Rating conditions is not implied.

RoHS status based on EUDirective2002/95/EC (at time of this document revision).

The information in this publication is believed to be accurate and reliable. However, no responsibility is assumed by RF Micro Devices, Inc. ("RFMD") for its use, nor for any infringement of patents, or other rights of third parties, resulting from its use. No license is granted by implication or otherwise under any patent or patent rights of RFMD. RFMD reserves the right to change component circuitry, recommended application circuitry and specifications at any time without prior notice.

Parameter	Specification			Unit	Condition
	Min.	Typ.	Max.		
<b>Recommended Operating Conditions</b>					
<b>Overall Power Control <math>V_{RAMP}</math></b>					
Power Control "ON"			2.1	V	Max. $P_{OUT}$ , Voltage supplied to the input
Power Control "OFF"	0.13			V	Min. $P_{OUT}$ , Voltage supplied to the input
$V_{RAMP}$ Input Capacitance			10.0	pF	DC to 2MHz
$V_{RAMP}$ Input Current			10.0	μA	$V_{RAMP} = V_{RAMP\ MAX}$
Turn On/Off Time			2.0	us	$V_{RAMP} = 0V$ to $V_{RAMP\ MAX}$
Power Control Range		50.0		dB	$V_{RAMP} = 0.13V$ to $V_{RAMP\ MAX}$
<b>Overall Power Supply</b>					
Power Supply Voltage		3.5		V	Specifications
	3.2		4.6	V	Nominal operating limits
Power Supply Current		1.0	20.0	μA	$P_{IN} < -30dBm$ , TX Enable = Low, $V_{RAMP} = 0V$ , Temp = -30 °C to +85 °C
<b>Overall Control Signals</b>					
VC1, VC2, VC3 "Low"	0		0.4	V	
VC1, VC2, VC3 "High"	1.38		2.86	V	
VC1, VC2, VC3 "High Current"			1	uA	
TX Enable "Low"	0	0	0.5		
TX Enable "High"	1.38		2.86	V	
TX Enable "High Current"			1	uA	

## Module Control and Antenna Switch Logic

Mode	TX_EN	VC1	VC2	VC3
Standby	0	0	0	0
Idle	1	0	0	0
LB RX	0	0	0	1
HB RX	0	0	1	1
LB TX	1	1	0	1
HB TX	1	1	1	1

Parameter	Specification			Unit	Condition
	Min.	Typ.	Max.		
<b>GSM850 Mode</b>					Nominal test conditions unless otherwise stated. All unused ports are terminated with 50Ω. Temp=+25°C, V <sub>BATT</sub> =3.5V, V <sub>RAMP</sub> =2.1V, P <sub>IN</sub> =0dBm, TX_EN=High, Duty Cycle=25%, Pulse Width=1154μs
Operating Frequency Range	824		849	MHz	
Input Power Range	-3.0	0	+3.0	dBm	
Input VSWR			3:1		Over all power levels (5dBm to 33dBm)
Maximum Output Power	33.1	34.0		dBm	Full P <sub>OUT</sub> guaranteed at minimum drive level
	32.1	32.7		dBm	Temp=+85°C, V <sub>BATT</sub> =3.2V, P <sub>IN</sub> =3dBm
Total Efficiency	28	34		%	P <sub>OUT</sub> =33.1dBm
Output Noise Power		-90	-86.5	dBm	869MHz to 894MHz, RBW=100kHz, P <sub>OUT</sub> ≤33.4dBm
Forward Isolation 1			-58	dBm	TX_EN=Low, P <sub>IN</sub> =-20dBm, V <sub>RAMP</sub> =0.13V
Forward Isolation 2			-40	dBm	TX_EN=High, P <sub>IN</sub> =-20dBm, V <sub>RAMP</sub> =0.13V
Harmonics up to 12.75GHz		-40	-36	dBm	Over all power levels (5dBm to 33dBm)
All Non-Harmonic Spurious			-35.0	dBm	Over all power levels (5dBm to 33dBm)
Output Load VSWR Stability			-36	dBm	VSWR=15:1; all phase angles, set V <sub>RAMP</sub> where P <sub>OUT</sub> ≤33.4dBm into 50Ω load
Output Load VSWR Ruggedness	No damage or permanent degradation.				VSWR=20:1; all phase angles, set V <sub>RAMP</sub> where P <sub>OUT</sub> ≤33.4dBm into 50Ω load.
Input and Output Impedance		50.0		Ω	
Delivered P <sub>OUT</sub> Range	30.55		32.8		Set V <sub>BATT</sub> =3.5V to 4.0V V <sub>RAMP</sub> where P <sub>OUT</sub> =32.8dBm at Load impedance=50Ω f=824MHz to 849MHz Change Load VSWR=3:1 all phases Measure delivered P <sub>OUT</sub> with P <sub>IN</sub> =-2dBm to +2dBm

Parameter	Specification			Unit	Condition
	Min.	Typ.	Max.		
<b>PCS1900 Mode</b>					Nominal test conditions unless otherwise stated. All unused ports are terminated with 50Ω. Temp = +25 °C, V <sub>BATT</sub> = 3.5V, V <sub>RAMP</sub> = 2.1V, P <sub>IN</sub> = 0dBm, TX_EN = High, Duty Cycle = 25%, Pulse Width = 1154 μs
Operating Frequency Range	1850		1910	MHz	
Input Power Range	-3.0	0	+3.0	dBm	
Input VSWR			3:1	dBm	Over all power levels (0dBm to 30dBm)
Maximum Output Power	31.4	32.5		dBm	Full P <sub>OUT</sub> guaranteed at minimum drive level
	30.4	31		dBm	Temp = +85 °C, V <sub>BATT</sub> = 3.2V, P <sub>IN</sub> = -3dBm
Total Efficiency	30	36		%	P <sub>OUT</sub> = 31.4dBm
Output Noise Power		-85	-79	dBm	1930MHz to 1990MHz, RBW = 100kHz, P <sub>OUT</sub> ≤ 31.9dBm
Forward Isolation 1			-52	dBm	TX_EN = Low, P <sub>IN</sub> = -20dBm, V <sub>RAMP</sub> = 0.13V
Forward Isolation 2			-40	dBm	TX_EN = High, P <sub>IN</sub> = -20dBm, V <sub>RAMP</sub> = 0.13V
All Harmonics up to 12.75GHz		-40	-36	dBm	Over all power levels (0dBm to 30dBm)
All Non-Harmonic Spurious			-28.0	dBm	Over all power levels (0dBm to 30dBm)
Output Load VSWR Stability			-36	dBm	VSWR = 15:1; all phase angles, set V <sub>RAMP</sub> where P <sub>OUT</sub> ≤ 31.9dBm into 50Ω load
Output Load VSWR Ruggedness	No damage or permanent degradation.				VSWR = 20:1; all phase angles, set V <sub>RAMP</sub> where P <sub>OUT</sub> ≤ 31.9dBm into 50Ω load.
Input and Output Impedance		50.0		Ω	
Delivered P <sub>OUT</sub> Range	28.65		30.9		Set V <sub>CC</sub> = 3.5V to 4.0V V <sub>RAMP</sub> where P <sub>OUT</sub> = 30.9dBm@ Load impedance = 50Ω f = 1850MHz to 1910MHz Change Load VSWR = 3:1 all phases Measure delivered P <sub>OUT</sub> with P <sub>IN</sub> = -2dBm to +2dBm

Parameter	Specification			Unit	Condition
	Min.	Typ.	Max.		
<b>RX-Section</b>					Nominal test conditions unless otherwise stated. All unused ports are terminated with 50Ω. Temp=+25°C, V <sub>BATT</sub> =3.5V, V <sub>RAMP</sub> =2.4V, TX_EN=Low.
Insertion Loss, ANT-RX1:Low Band		1.2	1.5	dB	869MHz to 894MHz
Insertion Loss, ANT-RX2:High Band		1.2	1.5	dB	1930MHz to 1990MHz
Ripple, RX1			0.2	dB	869MHz to 894MHz
Ripple, RX2			0.2	dB	1930MHz to 1990MHz
VSWR, ANT-RX1: Low Band			1.8:1		869MHz to 894MHz
VSWR, ANT-RX2: High Band			1.8:1		1930MHz to 1990MHz
<b>TX-Section</b>					Temp=+25°C, V <sub>BATT</sub> =3.5V, V <sub>RAMP</sub> =2.1V, P <sub>IN</sub> =0dBm, TX EN=High, Duty Cycle=25%, Pulse Width=1154μs
RF Leakage to RX Port P <sub>OUT</sub> at RX Port for Isolation					
GSM850 ANT-RX 1			0	dBm	GSM850 TX Mode:Frequency=824MHz to 849MHz, P <sub>OUT</sub> =+0dBm to +33dBm
GSM850 ANT-RX 2			0	dBm	GSM850 TX Mode:Frequency=824MHz to 849MHz, P <sub>OUT</sub> =+0dBm to +33dBm
PCS1900 ANT-RX 1			0	dBm	PCS1900 TX Mode:Frequency=1850MHz to 1910MHz, P <sub>OUT</sub> =-5dBm to +30dBm
PCS1900 ANT-RX 2			0	dBm	PCS1900 TX Mode:Frequency=1850MHz to 1910MHz, P <sub>OUT</sub> =-5dBm to +30dBm

Note: Isolation Calculation Example: Isolation=P<sub>OUT</sub>@ANT-P<sub>OUT</sub>@RXPort. Isolation LB(ANT-RX1)=33-10=23dB, Isolation HB(ANT-RX2)=30-8=22dB

Pin	Function	Description
1	GND	Ground.
2	VC1	Control Voltage 1, to switch between RX and TX.
3	VC2	Control Voltage 2, to switch between LB and HB.
4	VC3	Control Voltage 3 to get extra Isolation before TX burst.
5	GND	Ground.
6	GND	Ground.
7	RXOUT HB	High band RX output. This output covers the frequency range of PCS1900 RX bands. No DC voltage from the module allowed on this pin.
8	RXOUT LB	Low band RX output. This output covers the frequency range of GSM850 RX bands. No DC voltage from the module allowed on this pin.
9	GND	Ground.
10	GND	Ground.
11	GND	Ground.
12	GND	Ground.
13	ANT	Antenna terminal. No DC voltage from the module allowed on this pin.
14	GND	Ground.
15	GND	Ground.
16	GND	Ground.
17	GND	Ground.
18	GND	Ground.
19	VBATT	Supply Voltage for Module.
20	VBATT	Supply Voltage for Module.
21	VBATT	Supply Voltage for Module.
22	GND	Ground.
23	GND	Ground.
24	GND	Ground.
25	GND	Ground.
26	TXIN LB	TX RF input to PA for GSM850 TX band. AC-coupled.
27	TXIN HB	TX RF input to PA for PCS1900 TX band. AC-coupled.
28	TXP	TX enable signal, controls powering up power loop and bias circuit.
29	VPC	Power control voltage, ramps the output power up and down.
30	PAID	

**Pin Out**  
(Top View)

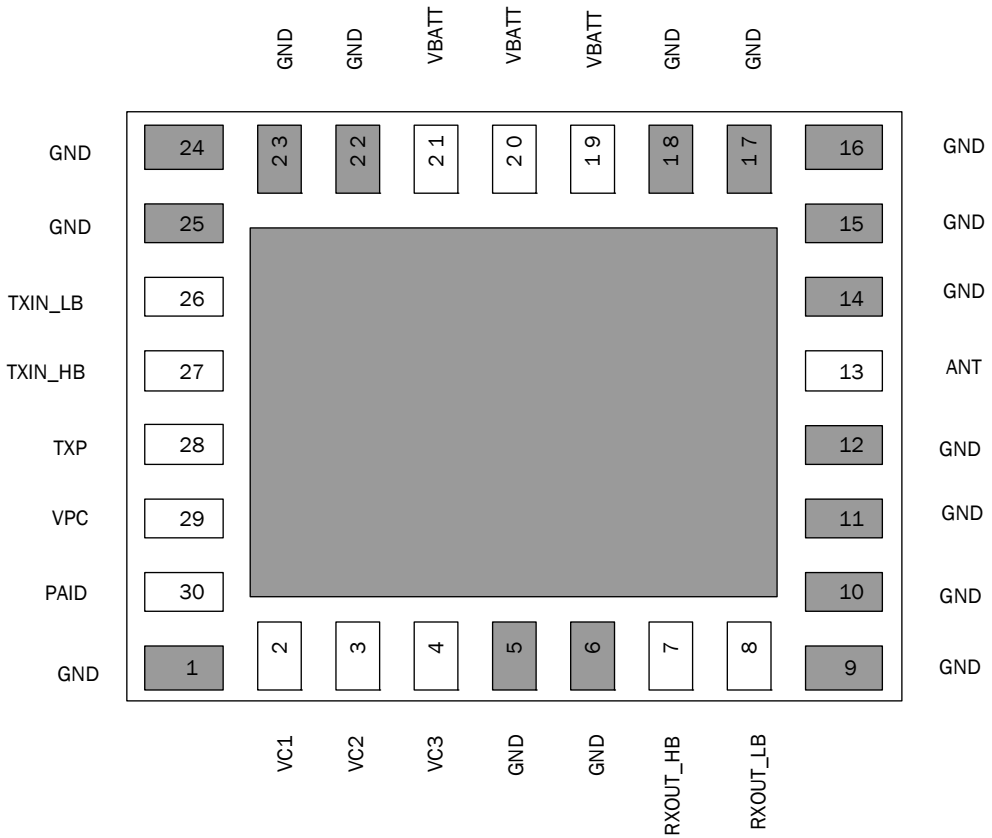

## Theory of Operation

### Product Description

The RF3285 is a high-power, high-efficiency, transmit module (TXM) with fully-integrated power control functionality, harmonic filtering, band selectivity, and TX/RX switching. The TXM is self-contained, with 50Ω I/O terminals with two RX ports allowing true dual-band operation. The power control function eliminates all power control circuitry, including directional couplers, diode detectors, and power control ASIC's, etc. The power control capability provides 50dB continuous control range, and 70dB total control range, using a DAC-compatible, analog voltage input. Output power variations into varying load impedance are minimized by the power control circuitry in order to meet Total Radiated Power (TRP) requirements. The TX Enable feature provides for PA activation (TX mode) or RX mode/Stand-by. Internal switching provides a low-loss, low-distortion path from the Antenna port to the TX path (or RX port), while maintaining proper isolation. Integrated filtering provides ETSI compliant harmonic suppression at the antenna port even under high mismatch conditions, which is important as modern antennas today often present a load that significantly deviates from nominal impedance.

### Overview

The RF3285 is a true dual-band GSM850/PCS1900 power amplifier module with fully integrated power control and antenna switch module eliminating the need for the complicated control loop design, harmonic filters, TX/RX switch and possible matching components. The power control loop can be driven directly from the DAC output in the baseband circuit. The module has two RX ports for GSM850/PCS1900 bands of operation. To control the mode of operation, there are four logic control signals: TX Enable, VC1, VC2, and VC3. If control signals are limited, VC3 may remain in the high state for all modes of operation.

### Module Control and Antenna Switch Logic

Mode	TX_EN	VC1	VC2	VC3
Standby	0	0	0	0
Low Band RX (GSM850)	0	0	0	1
High Band RX (PCS1900)	0	0	1	1
Low Band TX (PA On/Switch On) (GSM850)	1	1	0	1
High Band TX (PA On/Switch On) (PCS1900)	1	1	1	1

### Power Control Theory of Operation

Most power control systems in GSM sense either forward power or collector/drain current. The RF3285 uses RFMD's Power-Star™ collector voltage control instead of a power detector. A high-speed control loop is incorporated to regulate the collector voltage of the amplifier while the stages are held at a constant bias. The  $V_{RAMP}$  signal is multiplied by a factor of approximately 2.65, and the collector voltage for all three stages is regulated to the multiplied  $V_{RAMP}$  voltage. This circuit is what performs the  $V_{BATT}$  tracking so no external  $V_{RAMP}$  adjustment is necessary. By doing so, the power amplifier can operate over a wider range of  $V_{RAMP}$  values, and can meet transient spectrum requirements at lower  $V_{CC}$  values. In addition, a current mirror is added to sense the power amplifier current. This loop senses the current, and feeds a voltage back into the control loop, and the collector voltage is further compensated to limit power and current variation. This allows for more efficient operation under mismatch conditions. Under nominal conditions, this loop is not activated, and is seemingly transparent. The basic circuit is shown in the following diagram.



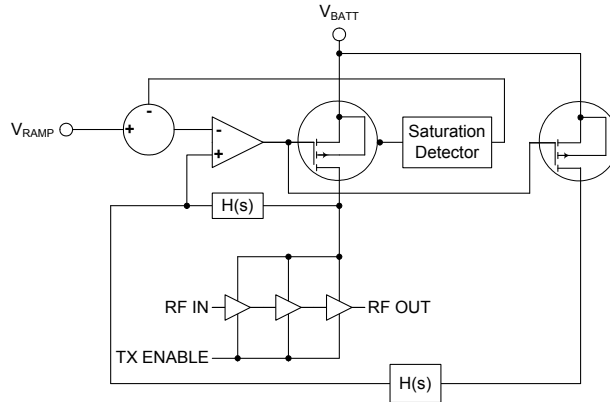

By regulating the power, the stages are held in saturation across all power levels. As the required output power is decreased from full power down to -15dBm, the collector voltage is also decreased. This regulation of output power is demonstrated in Equation 1 where the relationship between collector voltage and output power is shown. Although load impedance affects output power, supply fluctuations are the dominate mode of power variations. With the RF3285 regulating, there are several key factors to consider in the implementation of a transmitter solution for a mobile phone. Some of them are:

$$P_{dBm} = 10 \cdot \log \left[ \frac{(2 \cdot V_{CC} - V_{SAT})^2}{8 \cdot R_{LOAD} \cdot 10^{-3}} \right] \tag{Eq. 1}$$

- Effective efficiency ( $\eta_{EFF}$ )
- Current draw and system efficiency
- Power variation due to Supply Voltage
- Power variation due to frequency
- Power variation due to temperature
- Input impedance variation
- Noise power
- Loop stability
- Loop bandwidth variations across power levels
- Burst timing and transient spectrum trade offs
- Harmonics
- Post PA loss
- Insertion loss in receive ports
- TX power leakage into the RX ports
- Performance during VSWR
- Time needed to implement the solution
- Needed board area for the solution

Talk time and power management are key concerns in transmitter design since the power amplifier is the leading current consumer in a mobile terminal. Considering only the power amplifier's efficiency does not provide a true picture for the total system efficiency. It is important to consider effective efficiency which is represented by  $\eta_{EFF}$ . ( $\eta_{EFF}$  considers the loss between the PA and antenna and is a more accurate measurement to determine how much current will be drawn in the application).  $\eta_{EFF}$  is defined by the following relationship (Equation 2):

$$\eta_{EFF} = \frac{10^{\frac{P_{PA} + P_{LOSS}}{10}} - 10^{\frac{P_{IN}}{10}}}{V_{BAT} \cdot I_{BAT} \cdot 10} \quad (\text{Eq. 2})$$

Where  $P_{PA}$  is the output power from the PA,  $P_{LOSS}$  the insertion loss and  $P_{IN}$  the input power to the PA. The RF3285 improves the effective efficiency by minimizing the  $P_{LOSS}$  term in the equation. An ASM may have a typical loss of 1.2dB in LB and 1.4dB in high band. To be added to this is trace losses and mismatch losses. A post PA loss of 1.5dB in LB and 1.8dB in HB is common. With the integration of a low loss pHEMT switch and matching network in the same module, higher system efficiency can be achieved.

The components following the power amplifier often have insertion loss variation with respect to frequency. Usually, there is some length of microstrip that follows the power amplifier. There is also a frequency response found in directional couplers due to variation in the coupling factor over frequency, as well as the sensitivity of the detector diode. Since the RF3285 does not use a directional coupler with a diode detector, these variations do not occur. Also the TX/RX switch with low pass filters that usually follows the PA may contribute to frequency variation. The TX/RX switch incorporated in the RF3285 is very broadband and does not contribute to frequency roll off. Traditionally working with PA modules, some matching network is necessary between the PA output and the input of the TX/RX switch in order to get best possible performance. This work no longer has to be carried out, as this matching network is included in the RF3285.

Noise power in PA's where output power is controlled by changing the bias voltage is often a problem when backing off of output power. The reason is that the gain is changed in all stages and according to the noise formula (Equation 3),

$$F_{TOT} = F1 + \frac{F2 - 1}{G1} + \frac{F3 - 1}{G1 \cdot G2} \quad (\text{Eq. 3})$$

The noise figure depends on noise factor and gain in all stages. The bias point of the RF3285 is kept constant, therefore the gain in the first stage is always high and the overall noise power is not increased when decreasing output power.

Power control loop stability often presents many challenges to transmitter design. Designing a proper power control loop involves trade-offs affecting stability, transient spectrum and burst timing.

The RF3285 loop bandwidth is determined by internal bandwidth and does not change with respect to power levels. This makes it easier to maintain loop stability with a high bandwidth loop since the bias voltage and collector voltage do not vary. An often overlooked problem in PA control loops is that a delay not only decreases loop stability it also affects the burst timing when, for instance the input power from the VCO decreases (or increases) with respect to temperature or supply voltage. The burst timing then appears to shift to the right especially at low power levels. The RF3285 is insensitive to a change in input power and the burst timing is constant and requires no software compensation. Switching transients occur when the up and down ramp of the burst is not smooth enough or suddenly changes shape. If the control slope of a PA has an inflection point within the output power range or if the slope is simply too steep it is difficult to prevent switching transients. Controlling the output power by changing the collector voltage is as earlier described based on the physical relationship between voltage swing and output power. Furthermore, all stages are kept constantly biased so inflection points are nonexistent.

Harmonics are natural products of high efficiency power amplifier design. An ideal class "E" saturated power amplifier will produce a perfect square wave. Looking at the Fourier transform of a square wave reveals high harmonic content. Although this is common to all power amplifiers, there are other factors that contribute to conducted harmonic content as well. With most power control methods a peak power diode detector is used to rectify and sense forward power. Through the rectification process there is additional squaring of the waveform resulting in higher harmonics. The RF3285 address this by eliminating the need for the detector diode. In addition, the RF3285 provides integrated harmonic filtering. Therefore the harmonics coming out of the PA should represent the maximum power of the harmonics throughout the transmit chain. This is based upon proper harmonic termination of the transmit port.

**Performance under VSWR**

Often overlooked when designing transmitters is the fact that they normally operate under mismatch conditions while they are designed to operate only under perfect 50 ohm loads. This means that in the real application, performance is degraded. This performance degradation may include reduction in output power, increased harmonic levels, increased transient spectrum and catastrophic failures, breakdown. Traditionally designers have verified that the PA does not break during mismatch and this is all verification that has been carried out during mismatch. Modern antennas in handsets often present a load that significantly deviates from nominal impedance. A VSWR of 5:1 is not uncommon. In order not to disturb other phones in the same and close by cells, it is important that the ETSI specifications for transient spectrum, burst timing and spurious emission are fulfilled even during mismatch conditions. The RF3285 is designed to maintain its performance even under high antenna mismatch conditions.

The PowerStar™ methodology utilized in the RF3285 allows the transient spectrum in normal operation to be in the order of -35dBm to -40dBm but also both transient spectrum and the power versus time performance is unaffected even under mismatch conditions. Power output variation is minimized as well as the total current consumption. In addition, the harmonic level fluctuations are significantly decreased.

**TX/RX Switch**

The pHEMT switch integrated in the RF3285 allows for a low loss connection between the antenna port and the two RX ports. The insertion loss in the TX and RX paths is lower than the loss for a traditional pin-diode switch solution, which means lower current consumption in TX mode and better receiver sensitivity. The integrated switch also allows for less design complexity since there is no need for power amplifier to antenna switch matching.

## Evaluation Board Schematic

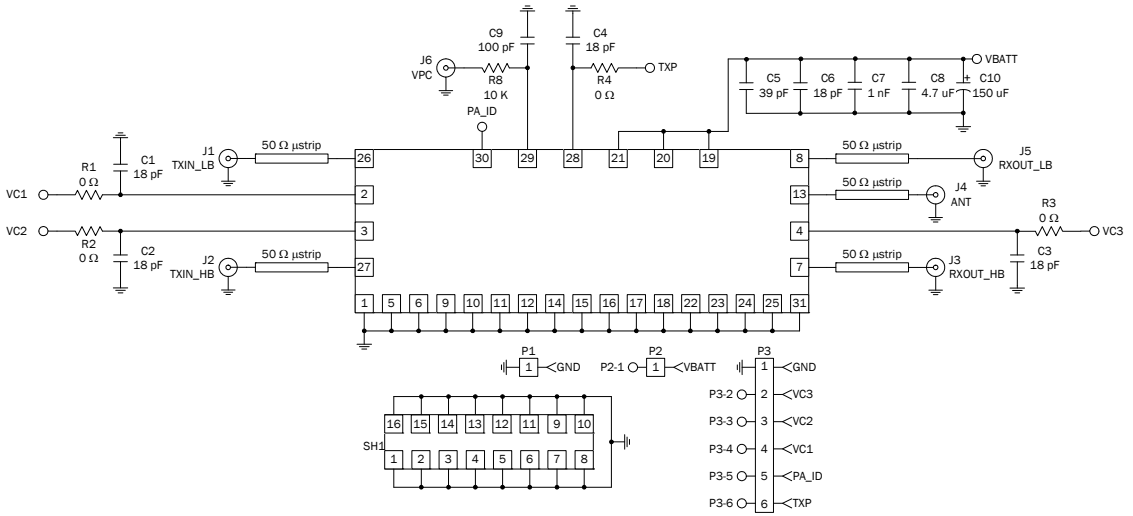

**Evaluation Board Layout**  
**Board Size 2.0" x 2.0"**  
**Board Thickness 0.034", Board Material FR-4**

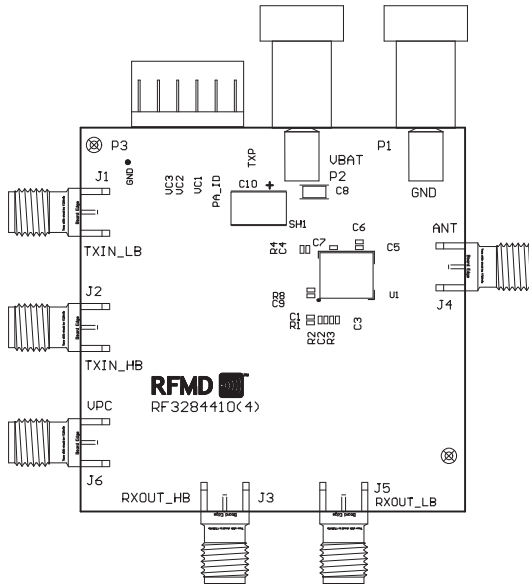

## Package Drawing

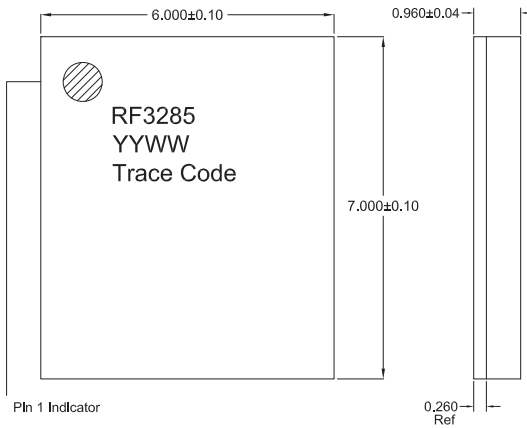

Fill in the YYWW notation with the Date Code  
 YY = Year  
 WW = Work Week

Trace Code to be assigned by SubCon

Notes:

1. Shaded area represents Pln 1 location
2. Defining I/O Pad Center:  
 To define center of the I/O pad opening, draw a right triangle in one corner of the I/O pad  
 Then take the center of the hypotenuse to determine center of I/O pad

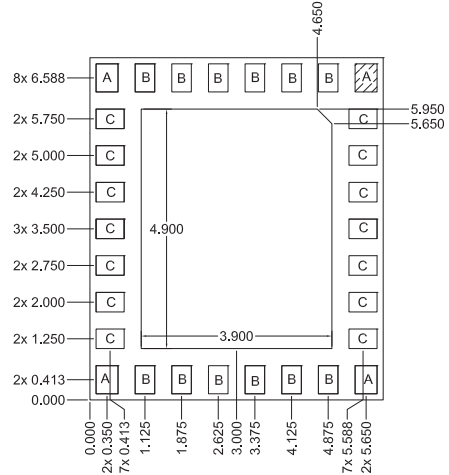

A = 0.450 x 0.575 mm Typ  
 B = 0.400 x 0.575 mm Typ  
 C = 0.575 x 0.400 mm Typ

## PCB Design Requirements

### PCB Surface Finish

The PCB surface finish used for RFMD's qualification process is electroless nickel, immersion gold. Typical thickness is 3 inch to 8 inch gold over 180 inch nickel.

### PCB Land Pattern Recommendation

PCB land patterns for RFMD components are based on IPC-7351 standards and RFMD empirical data. The pad pattern shown has been developed and tested for optimized assembly at RFMD. The PCB land pattern has been developed to accommodate lead and package tolerances. Since surface mount processes vary from company to company, careful process development is recommended.

### PCB Metal Land Pattern

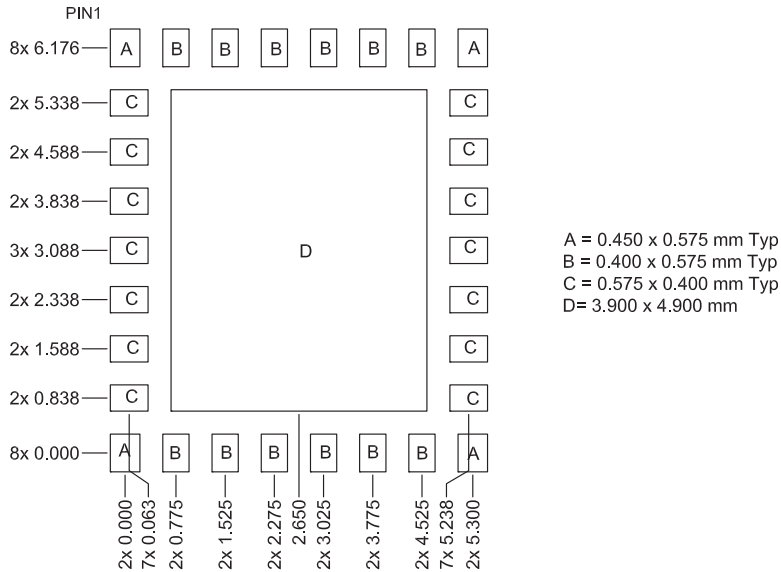

## PCB Solder Mask Pattern

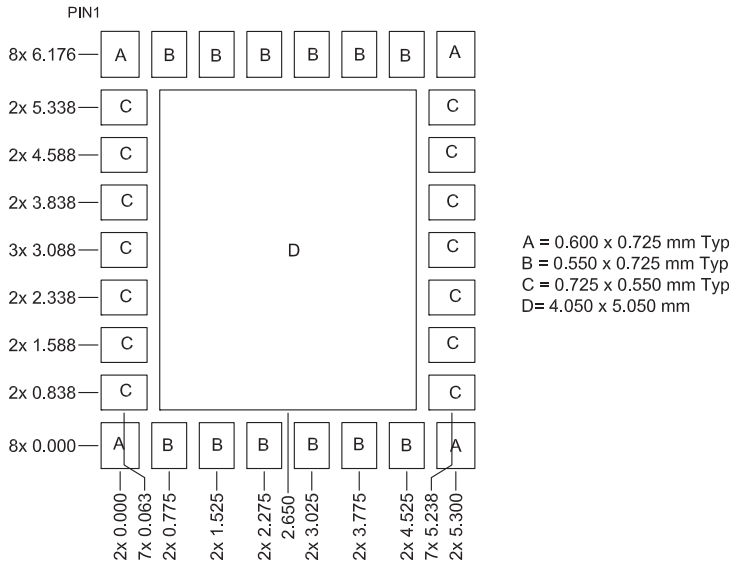

## PCB Stencil Pattern

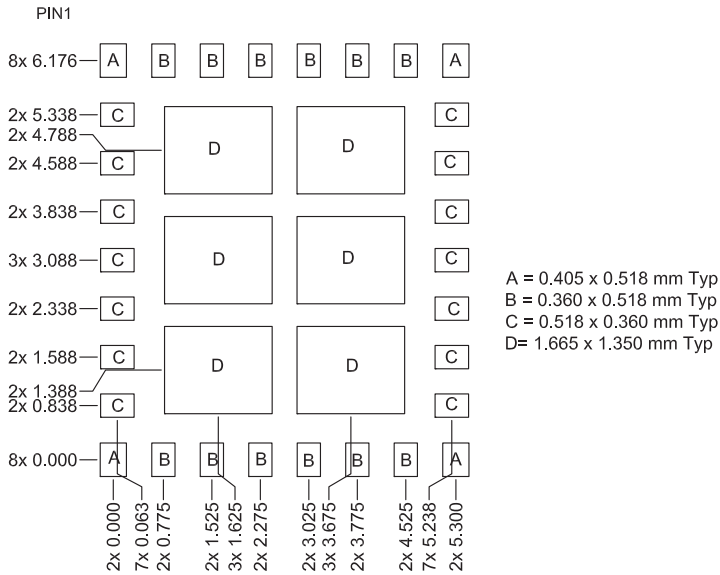



## Tape and Reel

Carrier tape basic dimensions are based on EIA 481. The pocket is designed to hold the part for shipping and loading onto SMT manufacturing equipment, while protecting the body and the solder terminals from damaging stresses. The individual pocket design can vary from vendor to vendor, but width and pitch will be consistent.

Carrier tape is wound or placed onto a shipping reel either 330mm (13 inches) in diameter or 178mm (7 inches) in diameter. The center hub design is large enough to ensure the radius formed by the carrier tape around it does not put unnecessary stress on the parts.

Prior to shipping, moisture sensitive parts (MSL level 2a-5a) are baked and placed into the pockets of the carrier tape. A cover tape is sealed over the top of the entire length of the carrier tape. The reel is sealed in a moisture barrier ESD bag with the appropriate units of desiccant and a humidity indicator card, which is placed in a cardboard shipping box. It is important to note that unused moisture sensitive parts need to be resealed in the moisture barrier bag. If the reels exceed the exposure limit and need to be rebaked, most carrier tape and shipping reels are not rated as bakeable at 125 °C. If baking is required, devices may be baked according to section 4, table 4-1, of Joint Industry Standard IPC/JEDEC J-STD-033.

The table below provides information for carrier tape and reels used for shipping the devices described in this document.

### Tape and Reel

RFMD Part Number	Reel Diameter Inch (mm)	Hub Diameter Inch (mm)	Width (mm)	Pocket Pitch (mm)	Feed	Units per Reel
<b>RF3285TR13</b>	13 (330)	4 (102)	16	8	Single	2500
<b>RF3285TR7</b>	7 (178)	2.4 (61)	16	8	Single	750

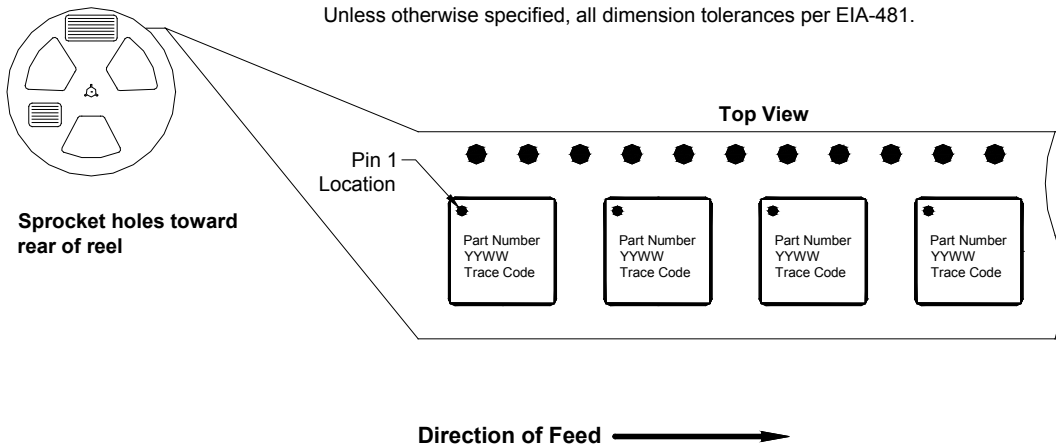

Figure 1. 5mmx5mm (Carrier Tape Drawing with Part Orientation)

