



Features

- Enhanced Performance Transmit Module
- No External Routing
- High Efficiency at Rated P_{OUT}
GSM850=40%
EGSM900=41%
DCS1800=37%
PCS1900=37%
- V_{BATT}=3.5V
- Low RX Insertion Loss
- Two Symmetrical RX Ports
- 0dBm to 6dBm Drive Level, >50dB of Dynamic Range
- Integrated Power-Flattening Circuit for Lower Power Variation under Mismatch Conditions
- V_{BATT} Tracking Circuit for Improved Switching Spectrum Performance under Low V_{BATT} Conditions

Applications

- 3V Quad-Band GSM/GPRS Handsets
- GSM850/EGSM900/DCS1800/PCS1900 Products
- Portable Battery-Powered Equipment

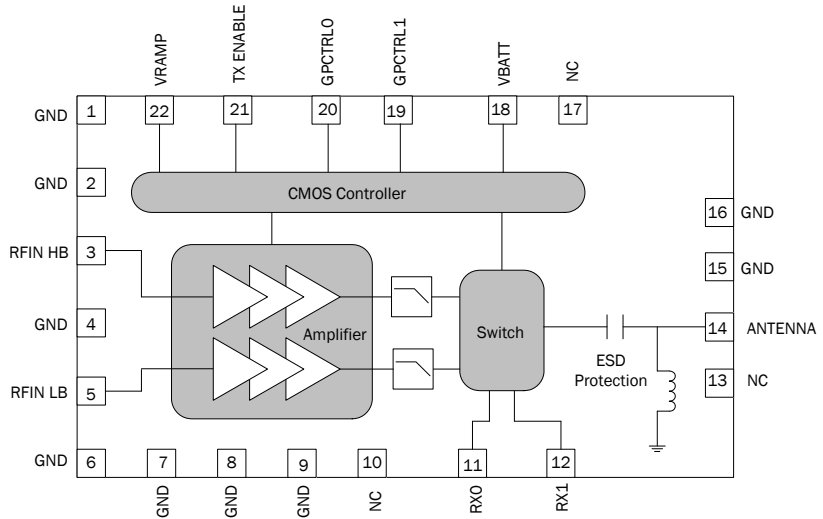

Functional Block Diagram

Product Description

The RF7170 is a quad-band (GSM850/EGSM900/DCS1800/PCS1900) GSM/GPRS, Class-12-compliant transmit module with two interchangeable receive ports. This transmit module builds upon RFMD's leading power amplifier with PowerStar® integrated power control technology, pHEMT switch technology, and integrated transmit filtering for best-in-class harmonic performance. The results are high performance, reduced solution size, and ease of implementation. The device is designed for use as the final portion of the transmitter section in a GSM850/EGSM900/DCS1800/PCS1900 handset, and eliminates the need for a PA-to-antenna switch module matching network.

The RF7170 features RFMD's latest integrated power-flattening circuit which significantly reduces current and power variation into load mismatch. Additionally, a VBATT tracking feature is incorporated to maintain switching performance as supply voltage decreases. The RF7170 also integrates an ESD filter to provide excellent ESD protection at the antenna port. The RF7170 is designed to provide maximum efficiency at rated P_{OUT}.

Ordering Information

| | |
|----------------|--|
| RF7170 | Quad-Band TX/Dual-Band RX GSM/GPRS Transmit Module |
| RF7170SB | Transmit Module 5-Piece Sample Pack |
| RF7170PCBA-41X | Fully Assembled Evaluation Board |

Optimum Technology Matching® Applied

- | | | | |
|--|--------------------------------------|--|------------------------------------|
| <input checked="" type="checkbox"/> GaAs HBT | <input type="checkbox"/> SiGe BiCMOS | <input checked="" type="checkbox"/> GaAs pHEMT | <input type="checkbox"/> GaN HEMT |
| <input type="checkbox"/> GaAs MESFET | <input type="checkbox"/> Si BiCMOS | <input checked="" type="checkbox"/> Si CMOS | <input type="checkbox"/> BiFET HBT |
| <input type="checkbox"/> InGaP HBT | <input type="checkbox"/> SiGe HBT | <input type="checkbox"/> Si BJT | <input type="checkbox"/> LDMOS |

RF MICRO DEVICES®, RFMD®, Optimum Technology Matching®, Enabling Wireless Connectivity™, PowerStar®, POLARIS™ TOTAL RADIO™ and UltimateBlue™ are trademarks of RFMD, LLC. BLUETOOTH is a trademark owned by Bluetooth SIG, Inc., U.S.A. and licensed for use by RFMD. All other trade names, trademarks and registered trademarks are the property of their respective owners. ©2006, RF Micro Devices, Inc.

Absolute Maximum Ratings

| Parameter | Rating | Unit |
|--------------------------------------|--------------|------|
| Supply Voltage | -0.3 to +6.0 | V |
| Power Control Voltage (V_{RAMP}) | -0.3 to +1.8 | V |
| Input RF Power | +10 | dBm |
| Max Duty Cycle | 50 | % |
| Output Load VSWR | 20:1 | |
| Operating Case Temperature | -20 to +85 | °C |
| Storage Temperature | -55 to +150 | °C |



Caution! ESD sensitive device.

Exceeding any one or a combination of the Absolute Maximum Rating conditions may cause permanent damage to the device. Extended application of Absolute Maximum Rating conditions to the device may reduce device reliability. Specified typical performance or functional operation of the device under Absolute Maximum Rating conditions is not implied.

RoHS status based on EUDirective2002/95/EC (at time of this document revision).

The information in this publication is believed to be accurate and reliable. However, no responsibility is assumed by RF Micro Devices, Inc. ("RFMD") for its use, nor for any infringement of patents, or other rights of third parties, resulting from its use. No license is granted by implication or otherwise under any patent or patent rights of RFMD. RFMD reserves the right to change component circuitry, recommended application circuitry and specifications at any time without prior notice.

| Parameter | Specification | | | Unit | Condition |
|------------------------------------|---------------|------|------------|------|--|
| | Min. | Typ. | Max. | | |
| ESD | | | | | |
| ESD Antenna Port | | | 8 | kV | IEC 61000-4-2 |
| ESD All Ports | | | 1000 | V | HBM, JES022-A114 |
| | | | 1000 | V | CDM, JEDEC JESD22-C101 |
| Overall Power Control | | | | | |
| V_{RAMP} | | | | | |
| Power Control "ON" | | | 1.8 | V | Max. P_{OUT} |
| Power Control "OFF" | | 0.25 | | V | Min. P_{OUT} |
| V_{RAMP} Input Capacitance | | 15 | 20 | pF | DC to 200kHz |
| V_{RAMP} Input Current | | | 10 | μA | $V_{RAMP} = V_{RAMP\ MAX}$ |
| Power Control Range | | 50 | | dB | $V_{RAMP} = 0.25V$ to $V_{RAMP, MAX}$ |
| Operating Limits | | | | | |
| Power Supply Range | 3.0 | 3.5 | 4.8 | V | Operating Limits |
| Power Supply Current | | 40 | 80 | μA | $P_{IN} < -30dBm$, TX Enable=Low, $V_{RAMP} = 0.25V$, Temp=-20 °C to +85 °C, $V_{BATT} = 4.8V$ |
| GpCtrl0/1 "Low" | 0 | 0 | 0.5 | V | |
| GpCtrl0/1 "High" | 1.25 | 2.0 | V_{BATT} | V | |
| GpCtrl0/1 "High Current" | | 1 | 2 | μA | |
| TX Enable "Low" | 0 | 0 | 0.5 | V | |
| TX Enable "High" | 1.25 | 2.0 | V_{BATT} | V | |
| TX Enable "High Current" | | 1 | 2 | μA | |
| RF Port Input and Output Impedance | | 50 | | Ω | |

| TX Enable | GpCtrl1 | GpCtrl0 | TX Module Mode |
|-----------|---------|---------|--------------------------|
| 0 | 0 | 0 | Low Power Mode (Standby) |
| 0 | 1 | 0 | RX0 RX Mode |
| 0 | 1 | 1 | RX1 RX Mode |
| 1 | 1 | 0 | GSM850/EGSM900 TX Mode |
| 1 | 1 | 1 | DCS1800/PCS1900 TX Mode |

| Parameter | Specification | | | Unit | Condition |
|---|---------------|--------|-------|------|---|
| | Min. | Typ. | Max. | | |
| GSM850 Mode | | | | | Nominal Conditions unless otherwise stated. All unused ports are terminated. $V_{BATT}=3.5V$, $P_{IN}=3dBm$, Temp= $+25^{\circ}C$, TX Enable=High, $V_{RAMP}=1.8V$, TX Mode: GpCtrl1=High, GpCtrl0=Low, Duty Cycle=25%, Pulse Width=1154 μs |
| Operating Frequency Range | 824 | | 849 | MHz | |
| Input Power | 0 | 3 | 6 | dBm | Full P_{OUT} guaranteed at minimum drive level. |
| Input VSWR | | 1.8:1 | 2.5:1 | | Over P_{OUT} range (5dBm to 33dBm) |
| Maximum Output Power | 33 | 34.2 | | dBm | Nominal Conditions |
| | 31 | 34.1 | | dBm | $V_{BATT}=3.1V$ to 4.8V, $P_{IN}=0dBm$ to 6dBm, Temp= $-20^{\circ}C$ to $+85^{\circ}C$, Duty Cycle=50%, Pulse Width=2308ms, $V_{RAMP}\leq 1.8V$ |
| Minimum Power Into 3:1 VSWR | 29.5 | 31.4 | | dBm | The measured delivered output power to the load with the mismatch loss already taken into account with 1dB variation margin. |
| Efficiency | 36 | 40 | | % | Set $V_{RAMP}=V_{RAMP RATED}$ for $P_{OUT}=33dBm$ |
| 2nd Harmonic | | -40 | -33 | dBm | $V_{RAMP}=V_{RAMP RATED}$ for $P_{OUT}=33dBm$ |
| 3rd Harmonic | | -40 | -33 | dBm | $V_{RAMP}=V_{RAMP RATED}$ for $P_{OUT}=33dBm$ |
| All Other Harmonics up to 12.75GHz | | | -33 | dBm | $V_{RAMP}=V_{RAMP RATED}$ for $P_{OUT}=33dBm$ |
| Non-Harmonic Spurious up to 12.75GHz | | | -36 | dBm | $V_{RAMP}=V_{RAMP RATED}$ for $P_{OUT}=33dBm$, also over all power levels (5dBm to 33dBm) |
| Forward Isolation 1 | | -59 | -41 | dBm | TX Enable=Low, $P_{IN}=6dBm$, $V_{RAMP}=0.25V$ |
| Forward Isolation 2 | | -27 | -15 | dBm | TX Enable=High, $P_{IN}=6dBm$, $V_{RAMP}=0.25V$ |
| Output Noise Power | | | | | |
| 869MHz to 894MHz | | -86.5 | -82 | dBm | $V_{RAMP}=V_{RAMP RATED}$ for $P_{OUT}=33dBm$, RBW=100kHz |
| 1930Hz to 1990MHz | | -117.5 | -74 | dBm | |
| Output Load VSWR Stability (Spurious Emissions) | | | -36 | dBm | VSWR=12:1; all phase angles. (Set $V_{RAMP}=V_{RAMP RATED}$ for $P_{OUT}\leq 33dBm$ into 50 Ω load; load switched to VSWR=12:1) |
| Output Load VSWR Ruggedness | | | | | VSWR=20:1; all phase angles. (Set $V_{RAMP}=V_{RAMP RATED}$ for $P_{OUT}\leq 33dBm$ into 50 Ω load; load switched to VSWR=20:1) |

| Parameter | Specification | | | Unit | Condition |
|---|---------------|--------|-------|------|---|
| | Min. | Typ. | Max. | | |
| EGSM900 Mode | | | | | Nominal Conditions unless otherwise stated. All unused ports are terminated. $V_{BATT}=3.5V$, $P_{IN}=3dBm$, Temp = +25 °C, TX Enable=High, $V_{RAMP}=1.8V$, TX Mode: GpCtrl1=High, GpCtrl0=Low, Duty Cycle=25%, Pulse Width = 1154 μ s |
| Operating Frequency Range | 880 | | 915 | MHz | |
| Input Power | 0 | 3 | 6 | dBm | Full P_{OUT} guaranteed at minimum drive level. |
| Input VSWR | | 1.7:1 | 2.5:1 | | Over P_{OUT} range (5dBm to 33dBm) |
| Maximum Output Power | 33 | 34.1 | | dBm | Nominal Conditions |
| | 31 | 34.0 | | dBm | $V_{BATT}=3.1V$ to 4.8V, $P_{IN}=0dBm$ to 6dBm, Temp = -20 °C to +85 °C, Duty Cycle=50%, Pulse Width = 2308ms, $V_{RAMP}\leq 1.8V$ |
| Minimum Power Into 3:1 VSWR | 30.0 | 31.4 | | dBm | The measured delivered output power to the load with the mismatch loss already taken into account with 1dB variation margin. |
| Efficiency | 36 | 41 | | % | Set $V_{RAMP}=V_{RAMP RATED}$ for $P_{OUT}=33dBm$ |
| 2nd Harmonic | | -40 | -33 | dBm | $V_{RAMP}=V_{RAMP RATED}$ for $P_{OUT}=33dBm$ |
| 3rd Harmonic | | -40 | -33 | dBm | $V_{RAMP}=V_{RAMP RATED}$ for $P_{OUT}=33dBm$ |
| All Other Harmonics up to 12.75GHz | | | -33 | dBm | $V_{RAMP}=V_{RAMP RATED}$ for $P_{OUT}=33dBm$ |
| Non-Harmonic Spurious up to 12.75GHz | | | -36 | dBm | $V_{RAMP}=V_{RAMP RATED}$ for $P_{OUT}=33dBm$, also over all power levels (5dBm to 33dBm) |
| Forward Isolation 1 | | -61 | -41 | dBm | TX Enable=Low, $P_{IN}=6dBm$, $V_{RAMP}=0.25V$ |
| Forward Isolation 2 | | -28 | -15 | dBm | TX Enable=High, $P_{IN}=6dBm$, $V_{RAMP}=0.25V$ |
| Output Noise Power | | | | | |
| 925 MHz to 935 MHz | | -86 | -77 | dBm | $V_{RAMP}=V_{RAMP RATED}$ for $P_{OUT}=33dBm$, RBW = 100 kHz |
| 935 MHz to 960 MHz | | -87 | -83 | dBm | |
| 1805 MHz to 1880 MHz | | -117.5 | -87 | dBm | |
| Output Load VSWR Stability (Spurious Emissions) | | | -36 | dBm | VSWR = 12:1; all phase angles. (Set $V_{RAMP}=V_{RAMP RATED}$ for $P_{OUT}\leq 33dBm$ into 50 Ω load; load switched to VSWR = 12:1) |
| Output Load VSWR Ruggedness | | | | | VSWR = 20:1; all phase angles. (Set $V_{RAMP}=V_{RAMP RATED}$ for $P_{OUT}\leq 33dBm$ into 50 Ω load; load switched to VSWR = 20:1) |

| Parameter | Specification | | | Unit | Condition |
|---|---------------|-------|-------|------|--|
| | Min. | Typ. | Max. | | |
| DCS1800 Mode | | | | | Nominal Conditions unless otherwise stated. All unused ports are terminated. $V_{BATT} = 3.5V$, $P_{IN} = 3dBm$, Temp = +25 °C, TX Enable = High, $V_{RAMP} = 1.8V$, TX Mode: GpCtrl1 = High, GpCtrl0 = High, Duty Cycle = 25%, Pulse Width = 1154 μs |
| Operating Frequency Range | 1710 | | 1785 | MHz | |
| Input Power | 0 | 3 | 6 | dBm | Full P_{OUT} guaranteed at minimum drive level. |
| Input VSWR | | 1.5:1 | 2.5:1 | | Over P_{OUT} range (0dBm to 30dBm) |
| Maximum Output Power | 30 | 31.5 | | dBm | Nominal Conditions |
| | 28 | 31.5 | | dBm | $V_{BATT} = 3.1V$ to 4.8V, $P_{IN} = 0dBm$ to 6dBm, Temp = -20 °C to +85 °C, Duty Cycle = 50%, Pulse Width = 2308ms, $V_{RAMP} \leq 1.8V$ |
| Minimum Power Into 3:1 VSWR | 27 | 28.5 | | dBm | The measured delivered output power to the load with the mismatch loss already taken into account with 1dB variation margin. |
| Efficiency | 32 | 37 | | % | Set $V_{RAMP} = V_{RAMP RATED}$ for $P_{OUT} = 30dBm$ |
| 2nd Harmonic | | -40 | -33 | dBm | $V_{RAMP} = V_{RAMP RATED}$ for $P_{OUT} = 30dBm$ |
| 3rd Harmonic | | -40 | -33 | dBm | $V_{RAMP} = V_{RAMP RATED}$ for $P_{OUT} = 30dBm$ |
| 4th Harmonic | | -36 | -30 | dBm | $V_{RAMP} = V_{RAMP RATED}$ for $P_{OUT} = 30dBm$ |
| All Other Harmonics up to 12.75GHz | | | -33 | dBm | $V_{RAMP} = V_{RAMP RATED}$ for $P_{OUT} = 30dBm$ |
| Non-Harmonic Spurious up to 12.75GHz | | | -36 | dBm | $V_{RAMP} = V_{RAMP RATED}$ for $P_{OUT} = 30dBm$, also over all power levels (0dBm to 30dBm) |
| Forward Isolation 1 | | -64 | -53 | dBm | TX Enable = Low, $P_{IN} = 6dBm$, $V_{RAMP} = 0.25V$ |
| Forward Isolation 2 | | -28 | -15 | dBm | TX Enable = High, $P_{IN} = 6dBm$, $V_{RAMP} = 0.25V$ |
| Output Noise Power | | | | | |
| 925MHz to 935MHz | | -101 | -77 | dBm | $V_{RAMP} = V_{RAMP RATED}$ for $P_{OUT} = 30dBm$, RBW = 100kHz |
| 935MHz to 960MHz | | -100 | -83 | dBm | |
| 1805MHz to 1880MHz | | -94 | -79 | dBm | |
| Output Load VSWR Stability (Spurious Emissions) | | | -36 | dBm | VSWR = 12:1; all phase angles. (Set $V_{RAMP} = V_{RAMP RATED}$ for $P_{OUT} \leq 30dBm$ into 50 Ω load; load switched to VSWR = 12:1) |
| Output Load VSWR Ruggedness | | | | | VSWR = 20:1; all phase angles. (Set $V_{RAMP} = V_{RAMP RATED}$ for $P_{OUT} \leq 30dBm$ into 50 Ω load; load switched to VSWR = 20:1) |

| Parameter | Specification | | | Unit | Condition |
|---|---------------|-------|-------|------|--|
| | Min. | Typ. | Max. | | |
| PCS1900 Mode | | | | | Nominal Conditions unless otherwise stated. All unused ports are terminated. $V_{BATT}=3.5V$, $P_{IN}=3\text{ dBm}$, Temp = +25 °C, TX Enable = High, $V_{RAMP}=1.8V$, TX Mode: GpCtrl1 = High, GpCtrl0 = High, Duty Cycle = 25%, Pulse Width = 1154 μs |
| Operating Frequency Range | 1850 | | 1910 | MHz | |
| Input Power | 0 | 3 | 6 | dBm | Full P_{OUT} guaranteed at minimum drive level. |
| Input VSWR | | 1.4:1 | 2.5:1 | | Over P_{OUT} range (0dBm to 30dBm) |
| Maximum Output Power | 30 | 31.2 | | dBm | Nominal Conditions |
| | 28 | 31.2 | | dBm | $V_{BATT}=3.1V$ to 4.8V, $P_{IN}=0\text{ dBm}$ to 6dBm, Temp = -20 °C to +85 °C, Duty Cycle = 50%, Pulse Width = 2308ms, $V_{RAMP}\leq 1.8V$ |
| Minimum Power Into 3:1 VSWR | 27 | 28.5 | | dBm | The measured delivered output power to the load with the mismatch loss already taken into account with 1dB variation margin. |
| Efficiency | 32 | 37 | | % | Set $V_{RAMP}=V_{RAMP\text{ RATED}}$ for $P_{OUT}=30\text{ dBm}$ |
| 2nd Harmonic | | -40 | -33 | dBm | $V_{RAMP}=V_{RAMP\text{ RATED}}$ for $P_{OUT}=30\text{ dBm}$ |
| 3rd Harmonic | | -40 | -33 | dBm | $V_{RAMP}=V_{RAMP\text{ RATED}}$ for $P_{OUT}=30\text{ dBm}$ |
| 4th Harmonic | | -36 | -30 | dBm | $V_{RAMP}=V_{RAMP\text{ RATED}}$ for $P_{OUT}=30\text{ dBm}$ |
| All Other Harmonics up to 12.75GHz | | | -33 | dBm | $V_{RAMP}=V_{RAMP\text{ RATED}}$ for $P_{OUT}=30\text{ dBm}$ |
| Non-Harmonic Spurious up to 12.75GHz | | | -36 | dBm | $V_{RAMP}=V_{RAMP\text{ RATED}}$ for $P_{OUT}=30\text{ dBm}$, also over all power levels (0dBm to 30dBm) |
| Forward Isolation 1 | | -66 | -53 | dBm | TX Enable = Low, $P_{IN}=6\text{ dBm}$, $V_{RAMP}=0.25V$ |
| Forward Isolation 2 | | -30 | -15 | dBm | TX Enable = High, $P_{IN}=6\text{ dBm}$, $V_{RAMP}=0.25V$ |
| Output Noise Power | | | | | |
| 869MHz to 894 MHz | | -102 | -82 | dBm | $V_{RAMP}=V_{RAMP\text{ RATED}}$ for $P_{OUT}=30\text{ dBm}$, RBW = 100 kHz |
| 1930MHz to 1990MHz | | -94 | -74 | dBm | |
| Output Load VSWR Stability (Spurious Emissions) | | | -36 | dBm | VSWR = 12:1; all phase angles. (Set $V_{RAMP}=V_{RAMP\text{ RATED}}$ for $P_{OUT}\leq 30\text{ dBm}$ into 50 Ω load; load switched to VSWR = 12:1) |
| Output Load VSWR Ruggedness | | | | | VSWR = 20:1; all phase angles. (Set $V_{RAMP}=V_{RAMP\text{ RATED}}$ for $P_{OUT}\leq 30\text{ dBm}$ into 50 Ω load; load switched to VSWR = 20:1) |

| Parameter | Specification | | | Unit | Condition |
|---|---------------|-------|-------|------|--|
| | Min. | Typ. | Max. | | |
| RX Section | | | | | Nominal Conditions unless otherwise stated. $V_{BATT}=3.5V$, $P_{IN}=-10dBm$, Temp = +25 °C, TX Enable = Low, $V_{RAMP}=0.2V$ RX0 Mode: GpCtrl1 = High, GpCtrl0 = Low, RX1 Mode: GpCtrl1 = High, GpCtrl0 = High, GSM850 RX = 869MHz to 894MHz, EGSM900 RX = 925MHz to 960MHz, DCS1800 RX = 1805MHz to 1880MHz PCS1900 RX = 1930MHz to 1990MHz |
| Insertion Loss GSM850/EGSM900 ANT-RX0/RX1 | | 1.0 | 1.3 | dB | RX0 Freq = GSM850 RX or EGSM900 RX. See Note 1. |
| In-Band Ripple GSM850/EGSM900 ANT-RX0/RX1 | | 0.05 | 0.2 | dB | RX0 Freq = GSM850 RX or EGSM900 RX |
| Input VSWR GSM850/EGSM900 ANT-RX0/RX1 | | 1.3:1 | 1.5:1 | | RX0 Freq = GSM850 RX or EGSM900 RX |
| Insertion Loss DCS1800/PCS1900 ANT-RX0/RX1 | | 1.3 | 1.6 | dB | Freq = 1805MHz to 1880MHz or 1930MHz to 1990MHz. See Note 1. |
| In-Band Ripple DCS1800/PCS1900 ANT-RX0/RX1 | | 0.1 | 0.2 | dB | Freq = 1805MHz to 1880MHz or 1930MHz to 1990MHz |
| Input VSWR DCS1800/PCS1900 ANT-RX0/RX1 | | 1.5:1 | 1.8:1 | | Freq = 1805MHz to 1880MHz or 1930MHz to 1990MHz |
| TX Section | | | | | |
| Switch Leakage P_{OUT} at RX Port GSM850/EGSM900 ANT-RX0/RX1 | | -18 | -10 | dBm | GSM850 TX mode: Freq = 824MHz to 849MHz, EGSM900 TX mode: Freq = 880MHz to 915MHz, GpCtrl1 = High, GpCtrl0 = Low, $V_{RAMP}=V_{RAMP\ RATED}$ for $P_{OUT}=33dBm$ at antenna port. See Note 2. |
| Switch Leakage P_{OUT} at RX Port DCS1800/PCS1900 ANT-RX0/RX1 | | -15 | -10 | | DCS1800 TX mode: Freq = 1710MHz to 1785MHz, PCS1900 TX mode: Freq = 1850MHz to 1910MHz, GpCtrl1 = High, GpCtrl0 = High, $V_{RAMP}=V_{RAMP\ RATED}$ for $P_{OUT}=30dBm$ at antenna port. See Note 2. |

Note 1: The insertion loss values listed take board resistive losses into account.

Note 2: Isolation specifications are set to ensure at least the following isolation at rated power. Calculation example using typical values: Switch Leakage = P_{OUT} at Antenna - P_{OUT} at RX Port. LB switch leakage = 33 - (-18) = 51dB, HB switch leakage = 30 - (-15) = 45dB.

| Pin | Function | Description |
|-----|-----------|---|
| 1 | GND | Ground. |
| 2 | GND | Ground. |
| 3 | RF IN HB | RF input to the DCS1800/PCS1900 bands. |
| 4 | GND | Ground. |
| 5 | RF IN LB | RF input to the GSM850/EGSM900 bands. |
| 6 | GND | Ground. |
| 7 | GND | Ground. |
| 8 | GND | Ground. |
| 9 | GND | Ground. |
| 10 | NC | No connect. |
| 11 | RX0 | RX0 of antenna switch. This port is interchangeable with RX1. |
| 12 | RX1 | RX1 of antenna switch. This port is interchangeable with RX0. |
| 13 | NC | No connect. |
| 14 | ANTENNA | Antenna port. This is a 50Ω output. |
| 15 | GND | Ground. |
| 16 | GND | Ground. |
| 17 | NC | No connect. |
| 18 | VBATT | Power supply for the module. This should be connected to the battery terminal using as wide a trace as possible. |
| 19 | GPCTRL1 | Control pin that together with GpCtrl0 selects the band of operation. |
| 20 | GPCTRL0 | Control pin that together with GpCtrl1 selects the band of operation. |
| 21 | TX ENABLE | This signal enables the PA module for operation with a logic high. The switch is put in TX mode determined by GpCtrl0 and GpCtrl1. |
| 22 | VRAMP | V _{RAMP} ramping signal from DAC. A simple RC filter is integrated into the RF7170 module. V _{RAMP} may or may not require additional filtering depending on the baseband selected. |
| 23 | GND | Ground. |

Pin Out

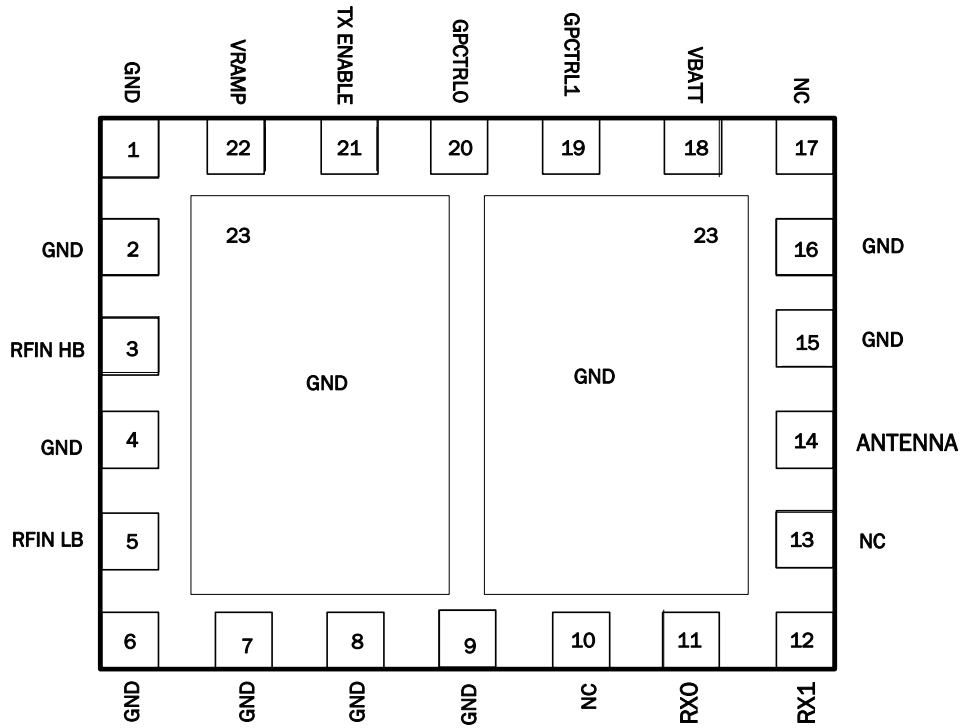

Theory of Operation

Product Description

The RF7170 is a dual-band, transmit module (TxM) with fully-integrated power control functionality, harmonic filtering, band selectivity, and TX/RX switching. The TxM is self-contained, having 50Ω I/O terminals and two symmetrical RX ports, allowing dual-band operation. The power control function eliminates all power control circuitry, including directional couplers, diode detectors, and power control ASICs, etc. The power control capability provides 50dB of continuous control range and 70dB of total dynamic range, using a DAC-compatible, analog voltage input. The TX Enable features provides for PA activation (TX mode) or RX mode/standby. Internal switching provides a low-loss, low-distortion path from the antenna port to the TX path (or RX port), while maintaining proper isolation. Integrated filtering provides ETSI-compliant harmonic suppression at the antenna port even under high mismatch conditions, which is important as modern antennas often present a load that significantly deviates from nominal impedance.

Overview

The RF7170 simplifies the phone design by eliminating the need for the complicated control loop, harmonic filters, and TX/RX switch along with their associated matching components. The power control loop can be driven directly from the DAC output in the baseband circuit. The module has two RX ports for GSM850/EGSM900 and DCS1800/PCS1900 bands of operation. The two RX ports are symmetrical; they can be used either as GSM850/EGSM900 and DCS1800/PCS1900 bands of operation. To control the mode of operation, there are three logic control signals: TX Enable, GpCtrl0, and GpCtrl1. RF7170 offers high efficiency at the rated P_{OUT} as backed-off efficiency is improved in this TxM.

Power Ramping and Timing

The RF7170 should be powered on according to the power-on sequence below. It is designed to prevent operation of the amplifier under conditions that could cause damage to the device or erratic operation.

There are some setup times associated with the control signals of the RF7170. The most important of these is the settling time between TXEN going high and when V_{RAMP} can begin to increase. This time is often referred to as the "pedestal" and is required so that the internal power control loop and bias circuitry can settle after being turned on. The RF7170 requires at least 2μs or two quarter-bit times for proper settling of the power control loop.

The power-down sequence is in opposite order of the power-on sequence. As described in the figure below, V_{BATT} is applied first to provide bias to the silicon control chip. Then the RF drive is applied. Finally, when TXEN is high, the V_{RAMP} signal is held at a constant 0.25V, and 2μs later, V_{RAMP} begins to ramp up. The shape of V_{RAMP} is important for maintaining the switching transients. The basic shape of the ramping function should be raised cosine to achieve best transient performance.

Power On Sequence

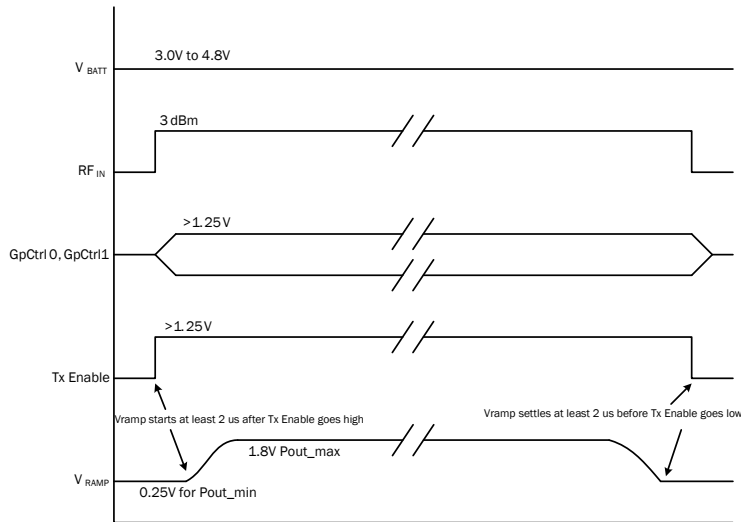

1. Apply VBATT
2. Apply GpCtrl0, GpCtrl1, RFIN and TX Enable
3. Apply VRAMP at least 2 μ s after TX Enable
4. The Power Down Sequence is in opposite order of the Power On Sequence.

Power Flattening and V_{BATT} Tracking

The RF7170 has an integrated power flattening circuit that reduces the amount of current variation when a mismatch is presented to the output of the PA. When a mismatch is presented to the output of the PA, its output impedance is varied and could present a load that will increase output power. As the output power increases, so does current consumption. The current consumption can become very high if not monitored and limited. The power flattening circuit is integrated onto the CMOS controller and requires no input from the user.

Into a mismatch, the current varies as the phase. The power flattening circuit monitors current through an internal sense resistor. As the current changes, the loop is adjusted in order to maintain current. The result is flatter power and reduced current into mismatch.

The RF7170 also incorporates a V_{BATT} tracking feature that eliminates the need for the transceiver/baseband to regulate the ramping signal as the supply voltage decreases. The internal circuit monitors the supply voltage and adjusts the ramping signal such that the switching spectrum is minimally impacted.

Application Schematic

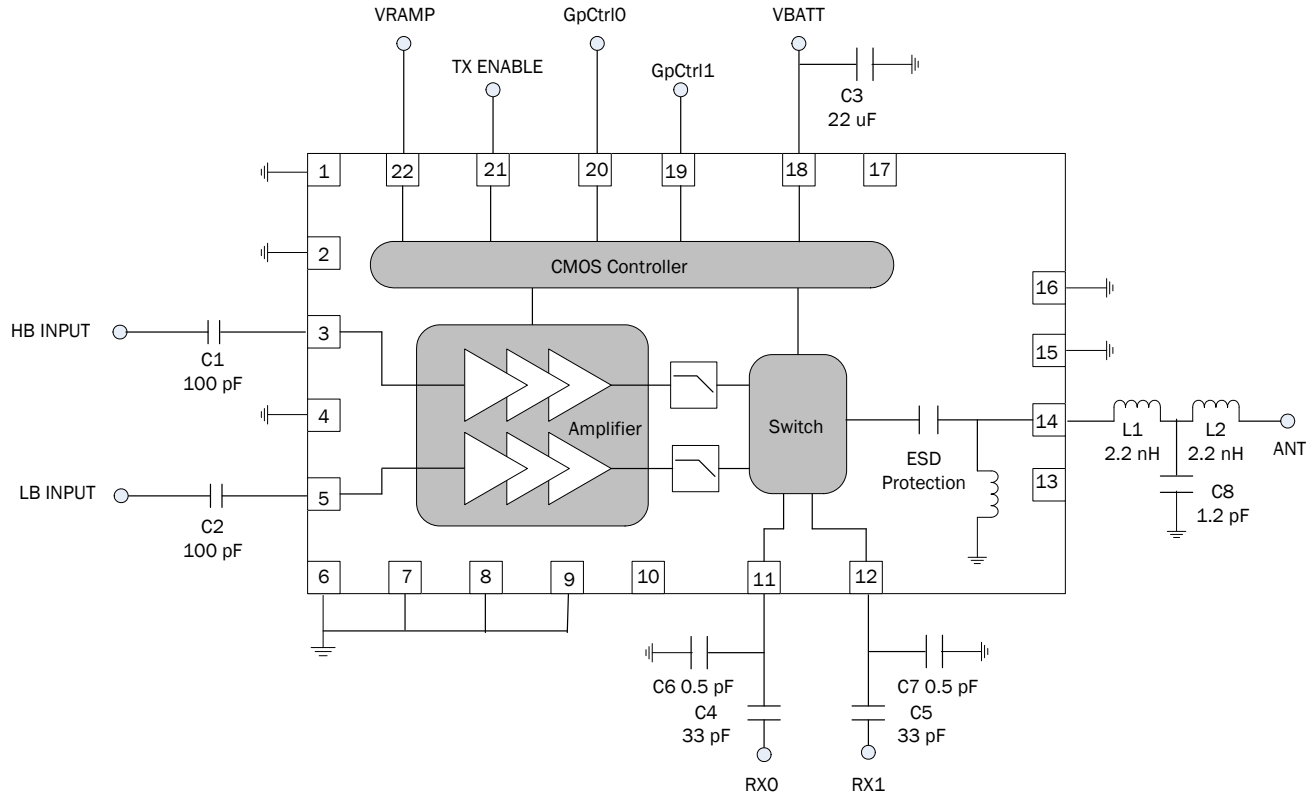

*All inputs, outputs, and antenna traces are 50 W micro strip.

**VBATT capacitor value may change depending on application.

***RX0 and RX1 usually connect to SAW filters; C4 and C5 are used to block dc voltage present on the RX ports. C6 and C7 are used to match the RX ports to a 50 W filter.

****If placing an attenuation network on the input to the power amplifier, ensure that it is positioned on the transceiver side of capacitor C1 (or C2) to prevent adversely affecting the base biasing of the power amplifier.

*****L1, L2, and C8 is a suggested external LPF to suppress higher order harmonics. Actual component values will depend on the application.

Evaluation Board Schematic

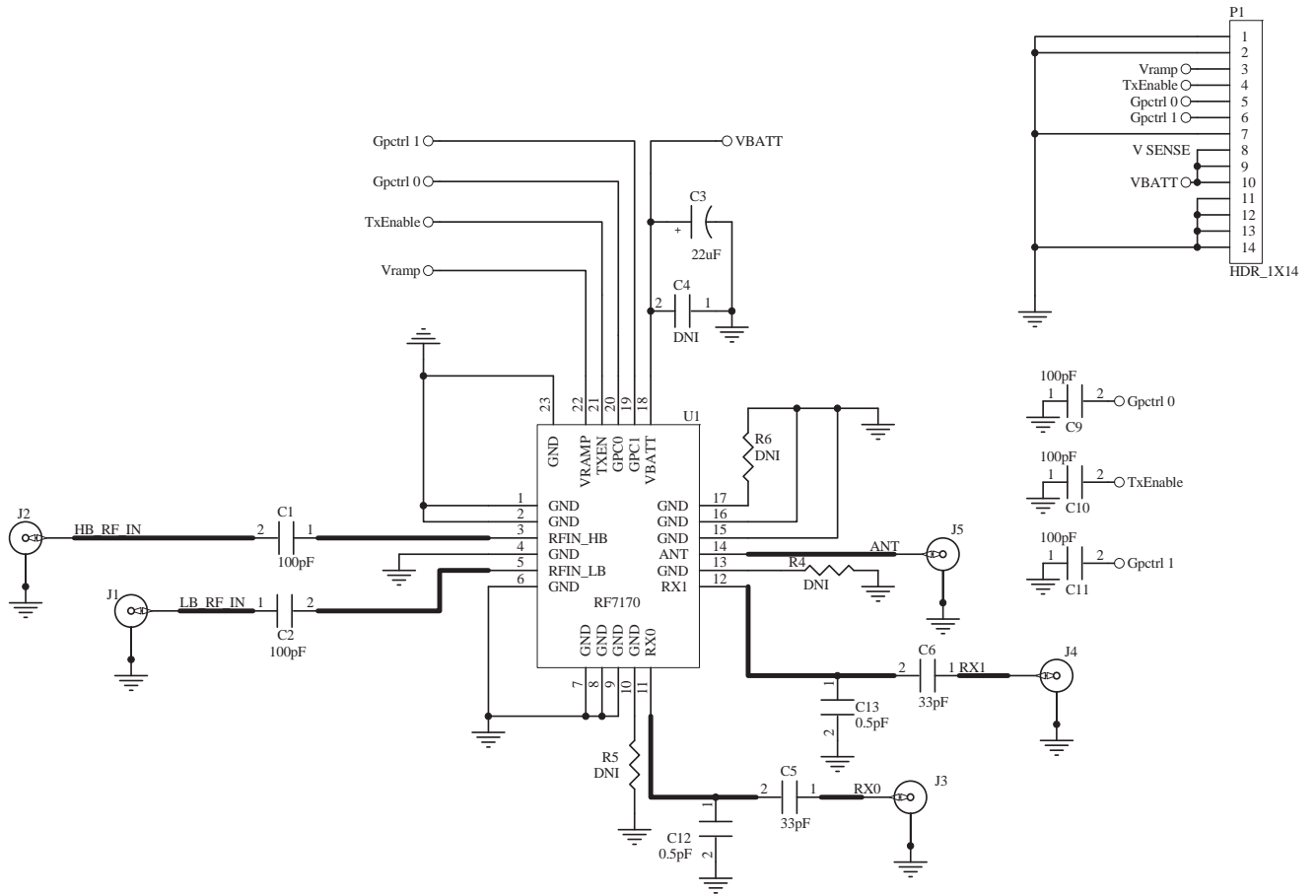

Evaluation Board Layout

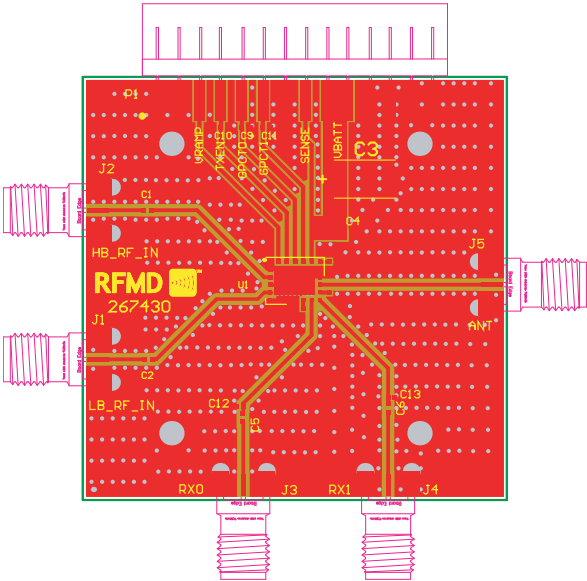

Package Drawing

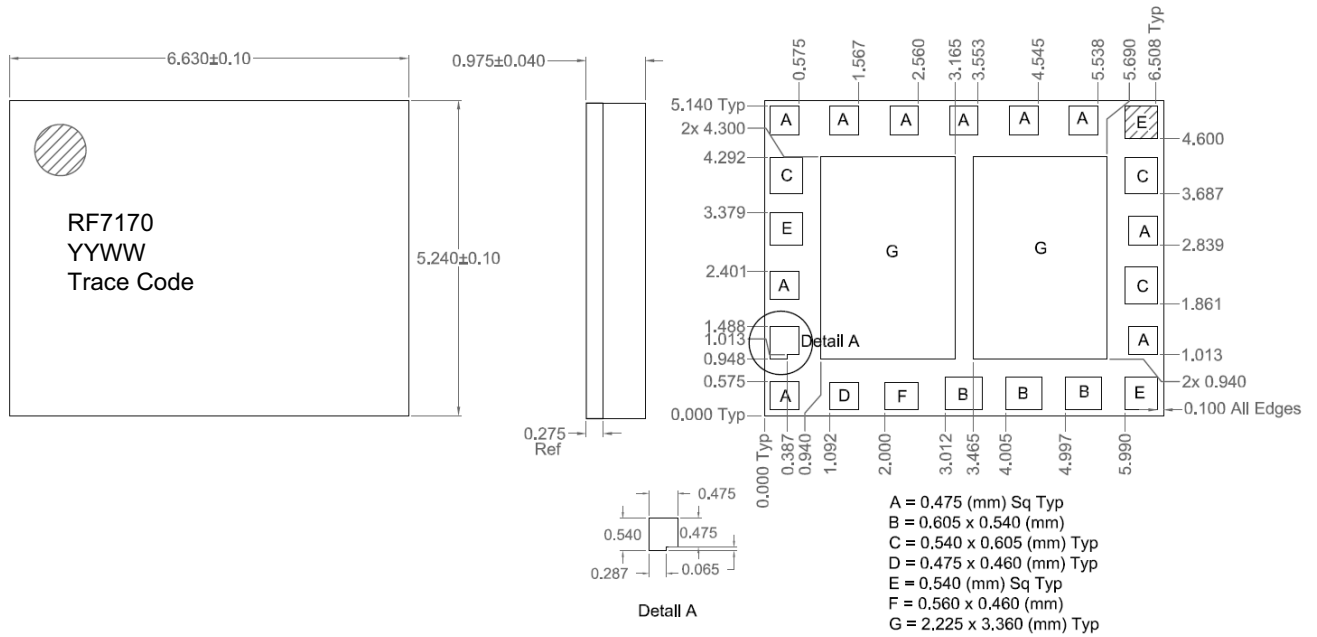

Notes:

YY indicates year, WW indicates work week, and Trace Code is a sequential number assigned at device assembly.

Shaded areas represent Pin 1 location.

PCB Design Requirements

PCB Surface Finish

The PCB surface finish used for RFMD's qualification process is electroless nickel, immersion gold. Typical thickness is 3µinch to 8µinch gold over 180µinch nickel.

PCB Land Pattern Recommendation

PCB land patterns for RFMD components are based on IPC-7351 standards and RFMD empirical data. The pad pattern shown has been developed and tested for optimized assembly at RFMD. The PCB land pattern has been developed to accommodate lead and package tolerances. Since surface mount processes vary from company to company, careful process development is recommended.

PCB Metal Land Pattern

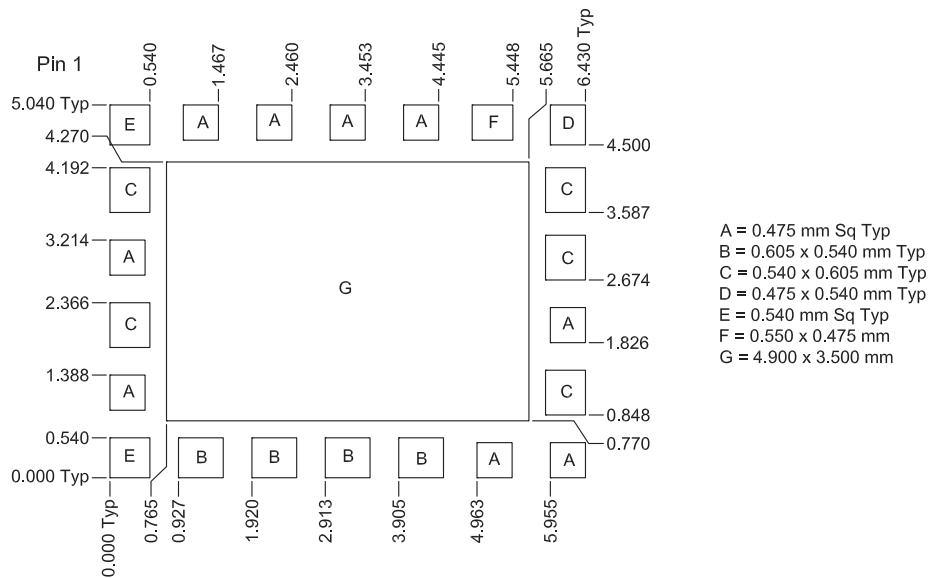

PCB Solder Mask Pattern

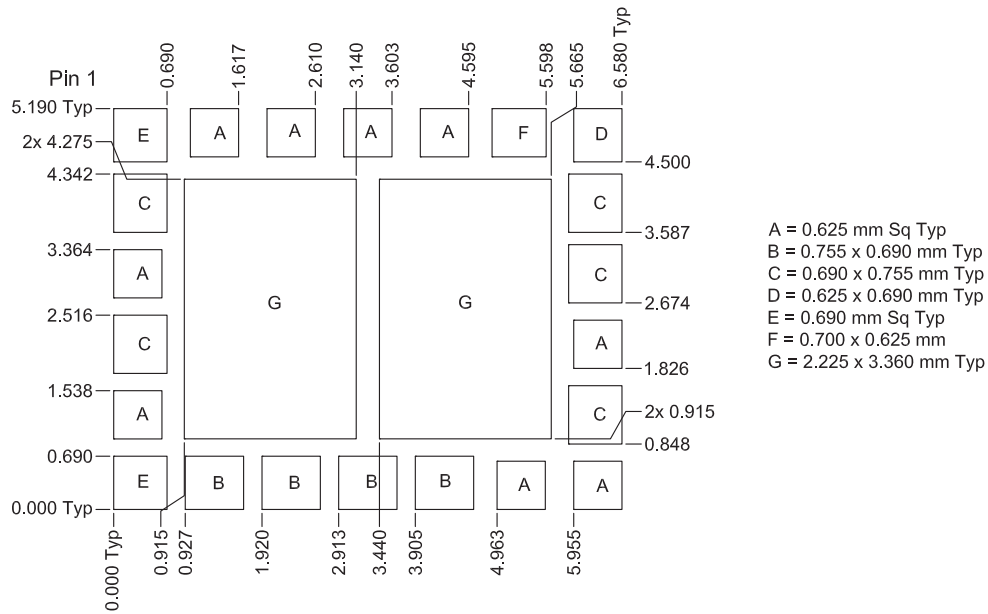

PCB Stencil Pattern

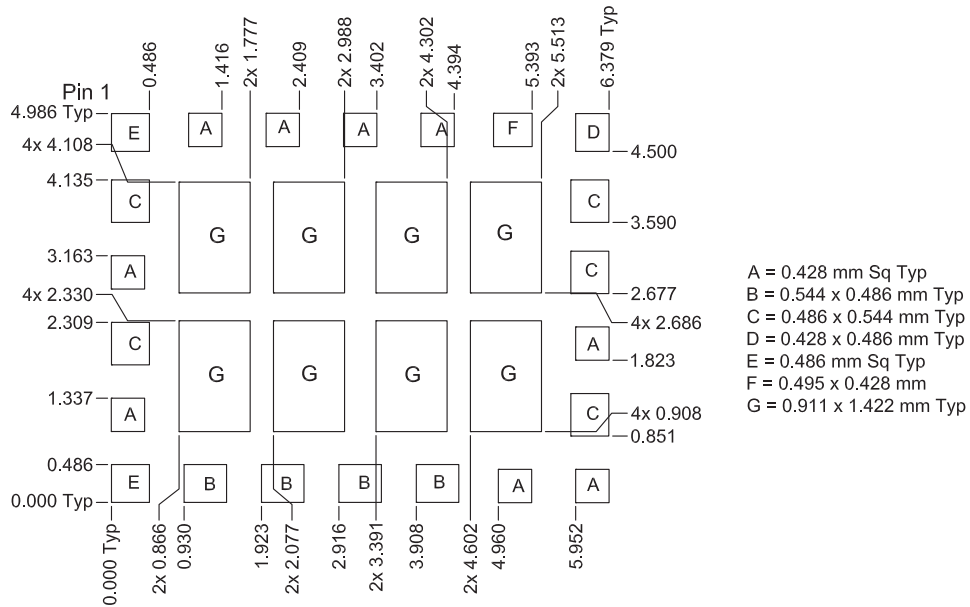

Tape and Reel Information

Carrier tape basic dimensions are based on EIA481. The pocket is designed to hold the part for shipping and loading onto SMT manufacturing equipment, while protecting the body and the solder terminals from damaging stresses. The individual pocket design can vary from vendor to vendor, but width and pitch will be consistent.

Carrier tape is wound or placed onto a shipping reel either 330 mm (13 inches) in diameter or 178 mm (7 inches) in diameter. The center hub design is large enough to ensure the radius formed by the carrier tape around it does not put unnecessary stress on the parts.

Prior to shipping, moisture sensitive parts (MSL level 2a-5a) are baked and placed into the pockets of the carrier tape. A cover tape is sealed over the top of the entire length of the carrier tape. The reel is sealed in a moisture barrier, ESD bag, which is placed in a cardboard shipping box. It is important to note that unused moisture sensitive parts need to be resealed in the moisture barrier bag. If the reels exceed the exposure limit and need to be rebaked, most carrier tape and shipping reels are not rated as bakeable at 125 °C. If baking is required, devices may be baked according to section 4, table 4-1, column 8 of Joint Industry Standard IPC/JEDEC J-STD-033A.

The following table provides useful information for carrier tape and reels used for shipping the devices described in this document.

| RFMD Part Number | Reel Diameter Inch (mm) | Hub Diameter Inch (mm) | Width (mm) | Pocket Pitch (mm) | Feed | Units per Reel |
|------------------|-------------------------|------------------------|------------|-------------------|--------|----------------|
| RF7170TR13 | 13 (330) | 4 (102) | 12 | 8 | Single | 2500 |
| RF7170TR7 | 7 (178) | 2.4 (61) | 12 | 8 | Single | 750 |

QFN (Carrier Tape Drawing with Part Orientation)

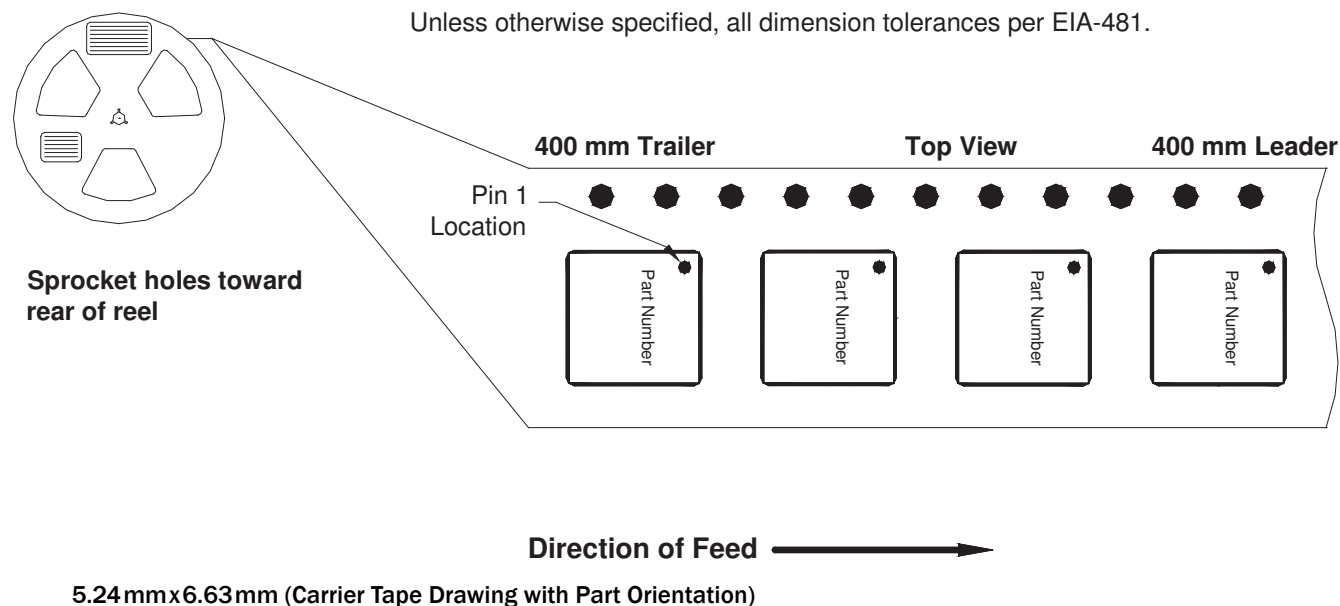

RoHS* Banned Material Content

RoHS Compliant: Yes
 Package total weight in grams (g): 0.121
 Compliance Date Code: -
 Bill of Materials Revision: -
 Pb Free Category: e4

| Bill of Materials | Parts Per Million (PPM) | | | | | |
|-------------------|-------------------------|----|----|-------|-----|------|
| | Pb | Cd | Hg | Cr VI | PBB | PBDE |
| Die | 0 | 0 | 0 | 0 | 0 | 0 |
| Molding Compound | 0 | 0 | 0 | 0 | 0 | 0 |
| Lead Frame | 0 | 0 | 0 | 0 | 0 | 0 |
| Die Attach Epoxy | 0 | 0 | 0 | 0 | 0 | 0 |
| Wire | 0 | 0 | 0 | 0 | 0 | 0 |
| Solder Plating | 0 | 0 | 0 | 0 | 0 | 0 |

This RoHS banned material content declaration was prepared solely on information, including analytical data, provided to RFMD by its suppliers, and applies to the Bill of Materials (BOM) revision noted above.

* DIRECTIVE 2002/95/EC OF THE EUROPEAN PARLIAMENT AND OF THE COUNCIL of 27 January 2003 on the restriction of the use of certain hazardous substances in electrical and electronic equipment