



### Features

- Enhanced Performance Transmit Module
- No External Routing
- High Efficiency at rated  $P_{OUT}$   
 $V_{BATT} = 3.5V$   
 GSM850 42%  
 EGSM900 40%  
 DCS1800 36%  
 PCS1900 37%
- 8kV Robust ESD Protection at Antenna Port
- Low Rx Insertion Loss
- Symmetrical Rx Ports
- 0dBm to 6dBm Drive Level, >50dB of Dynamic Range
- Integrated Power Flattening Circuit

### Applications

- 3V Quad-Band GSM/GPRS Handsets
- GSM850/PCS1900 or EGSM900/DCS1800 Products
- GPRS Class 12 Compliant
- Portable Battery-Powered Equipment

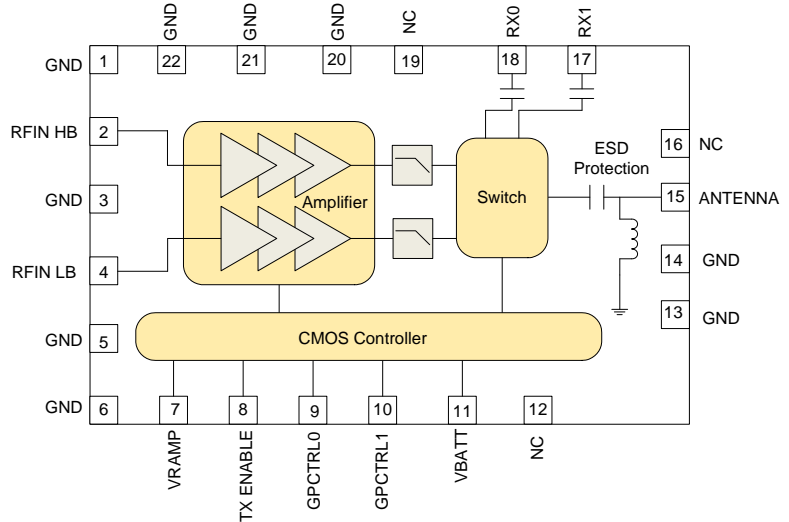

Functional Block Diagram

### Product Description

The RF7182 is a quad-band GSM/GPRS Class 12 compliant transmit module (GSM850/EGSM900/DCS1800/PCS1900) with two symmetrical receive ports. This transmit module builds upon RFMD's leading power amplifier with PowerStar® integrated power control technology, pHEMT switch technology, and integrated transmit filtering for best-in-class harmonic performance. The results are high performance, a reduced solution size, and ease of implementation. The device is designed for use as the final portion of the transmitter section in a GSM850/EGSM900/DCS1800/PCS1900 handset and eliminates the need for PA-to-antenna switch module matching network.

The RF7182 features RFMD's latest integrated power-flattening circuit, which significantly reduces current and power variation into load mismatch. The RF7182 also integrates an ESD filter to provide excellent ESD protection at the antenna port. The RF7182 is designed to provide maximum efficiency at rated  $P_{OUT}$ .

RF7182	Quad-Band Tx, Dual-Band Rx GSM, GPRS Transmit Module
RF7182SB	Transmit Module 5-Piece Sample Pack
RF7182PCBA-41X	Fully Assembled Evaluation Board

### Optimum Technology Matching® Applied

- |  |                                      |  |                                    |
|--|--------------------------------------|--|------------------------------------|
| <input checked="" type="checkbox"/> GaAs HBT | <input type="checkbox"/> SiGe BiCMOS | <input checked="" type="checkbox"/> GaAs pHEMT | <input type="checkbox"/> GaN HEMT  |
| <input type="checkbox"/> GaAs MESFET         | <input type="checkbox"/> Si BiCMOS   | <input checked="" type="checkbox"/> Si CMOS    | <input type="checkbox"/> BiFET HBT |
| <input type="checkbox"/> InGaP HBT           | <input type="checkbox"/> SiGe HBT    | <input type="checkbox"/> Si BJT                | <input type="checkbox"/> LDMOS     |

RF MICRO DEVICES®, RFMD®, Optimum Technology Matching®, Enabling Wireless Connectivity™, PowerStar®, POLARIS™ TOTAL RADIO™ and UltimateBlue™ are trademarks of RFMD, LLC. BLUETOOTH is a trademark owned by Bluetooth SIG, Inc., U.S.A. and licensed for use by RFMD. All other trade names, trademarks and registered trademarks are the property of their respective owners. ©2011, RF Micro Devices, Inc.

# RF7182



rfmd.com

**Please contact  
RFMD Technical Support  
at (336) 678-5570  
for more information.**