



**Features**

- RF Frequency: 17.7GHz to 19.7GHz
- LO Frequency: 6.85GHz to 11.85GHz
- IF Frequency: DC to 4GHz
- Conversion Gain (Max): 21dB
- Conversion Gain (Min): -5dB
- NF (Max. Gain): 9dB
- NF (Min. Gain): 18dB
- OIP3 (Max. Gain): +28dBm
- OIP3 (Min. Gain): +10dBm
- Image Rejection:  $\geq 15$ dBc

**Applications**

- Point-to-Point
- VSAT

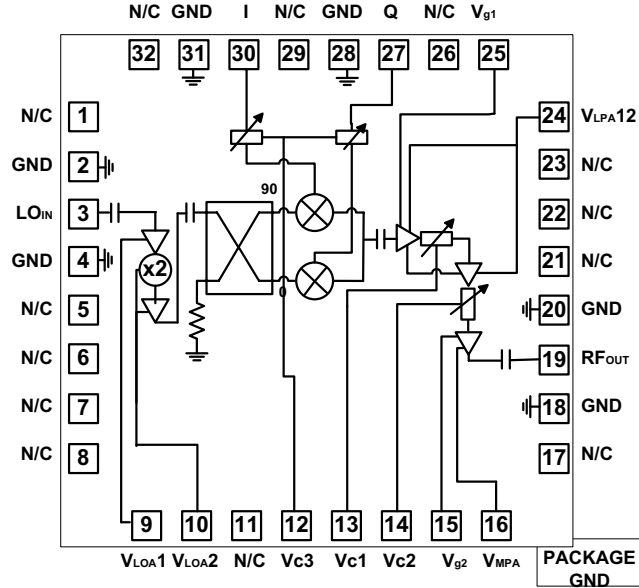

Functional Block Diagram

**Product Description**

RFMD's RFUV1702 is a 17.7GHz to 19.7GHz GaAs pHEMT upconverter, incorporating an integrated frequency multiplier (x2), LO buffer amplifier, a balanced single sideband (image rejection) mixer followed by variable gain amplifier, DC decoupling capacitors. The combination of high performance part and low-cost packaging makes the RFUV1702 a cost effective solution, ideally suited to both current and next generation point-to-point and VSAT applications. RFUV1702 is packaged in a 5mm x 5mm QFN to simplify both system level board design and volume assembly.

**Ordering Information**

RFUV1702S2	2-Piece Sample Bag
RFUV1702SB	5-Piece Bag
RFUV1702SQ	25-Piece Bag
RFUV1702SR	100 Pieces on 7" reel
RFUV1702TR7	750 Pieces on 7" reel
RFUV1702PCBA-410	Evaluation Board

**Optimum Technology Matching® Applied**

- |                                      |                                      |  |                                    |
|--------------------------------------|--------------------------------------|--|------------------------------------|
| <input type="checkbox"/> GaAs HBT    | <input type="checkbox"/> SiGe BiCMOS | <input checked="" type="checkbox"/> GaAs pHEMT | <input type="checkbox"/> GaN HEMT  |
| <input type="checkbox"/> GaAs MESFET | <input type="checkbox"/> Si BiCMOS   | <input type="checkbox"/> Si CMOS               | <input type="checkbox"/> BiFET HBT |
| <input type="checkbox"/> InGaP HBT   | <input type="checkbox"/> SiGe HBT    | <input type="checkbox"/> Si BJT                |                                    |

RF MICRO DEVICES®, RFMD®, Optimum Technology Matching®, Enabling Wireless Connectivity™, PowerStar®, POLARIS™ TOTAL RADIO™ and UltimateBlue™ are trademarks of RFMD, LLC. BLUETOOTH is a trademark owned by Bluetooth SIG, Inc., U.S.A. and licensed for use by RFMD. All other trade names, trademarks and registered trademarks are the property of their respective owners. ©2012, RF Micro Devices, Inc.

## Absolute Maximum Ratings

Parameter	Rating	Unit
LPA Drain Voltage $V_D$	6	V
LOA Drain Voltage	6	V
IF Input Power	15	dBm
LO Input Power	15	dBm
$T_{OPER}$	-40 to +85	°C
$T_{STOR}$	-65 to +150	°C
ESD Human Body Model	Class 1A	



**Caution!** ESD sensitive device.

Exceeding any one or a combination of the Absolute Maximum Rating conditions may cause permanent damage to the device. Extended application of Absolute Maximum Rating conditions to the device may reduce device reliability. Specified typical performance or functional operation of the device under Absolute Maximum Rating conditions is not implied.

The information in this publication is believed to be accurate and reliable. However, no responsibility is assumed by RF Micro Devices, Inc. ("RFMD") for its use, nor for any infringement of patents, or other rights of third parties, resulting from its use. No license is granted by implication or otherwise under any patent or patent rights of RFMD. RFMD reserves the right to change component circuitry, recommended application circuitry and specifications at any time without prior notice.



RFMD Green: RoHS compliant per EU Directive 2002/95/EC, halogen free per IEC 61249-2-21, < 1000ppm each of antimony trioxide in polymeric materials and red phosphorus as a flame retardant, and <2% antimony in solder.

Parameter	Specification			Unit	Condition
	Min.	Typ.	Max.		
RF Frequency	17.7		19.7	GHz	
LO Frequency	6.85		11.85	GHz	
IF Frequency	DC		4.0	GHz	
LO input Drive		0		dBm	
Conversion Gain (Max.)		21		dB	
Conversion Gain (Min.)		-5		dB	
NF (Max. Gain)		9		dB	
NF (-5dB Gain)		18		dB	
OIP3 (Max. Gain)		28		dBm	
OIP3 (-5dB Gain)		10		dBm	
Image Rejection		15		dBc	
LO Leakage at RF-Port (Max. Gain)		-5		dBm	With IQ bias
LO Return Loss		10		dB	
RF Return Loss		10		dB	
$V_D$		4.5		V	
$I_D$		480		mA	
VVA	-4		0	V	

**Typical Electrical Performance**

Measurements performed on connectorized evaluation board as shown on P.8 with I and Q (IF) ports connected to an external 90° Hybrid, LO Power = 0dBm and IF = 2.5GHz, -10dBm, unless otherwise stated.

**USB Conversion Gain, Image Rejection, OIP3 and LO Leakage**

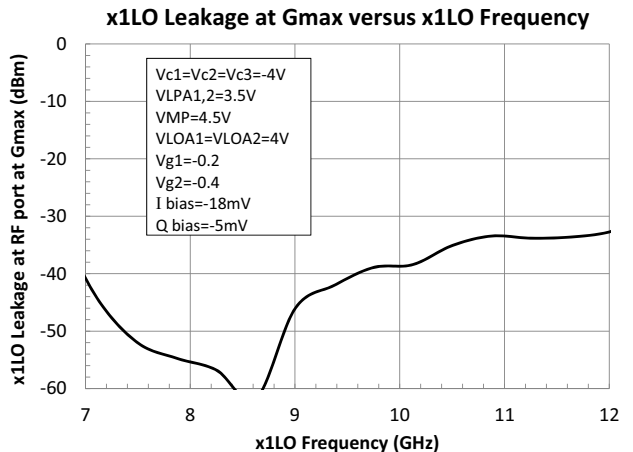
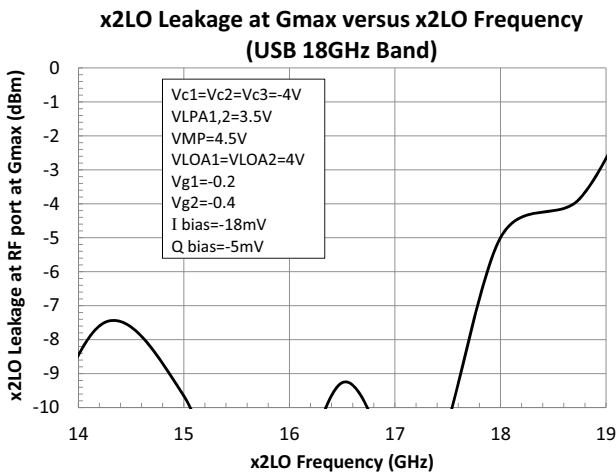
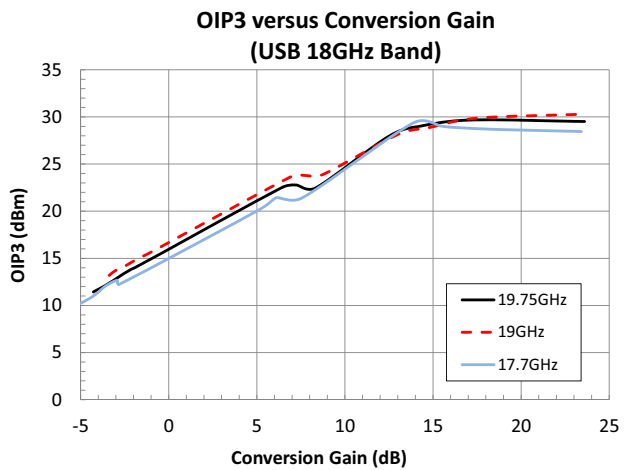
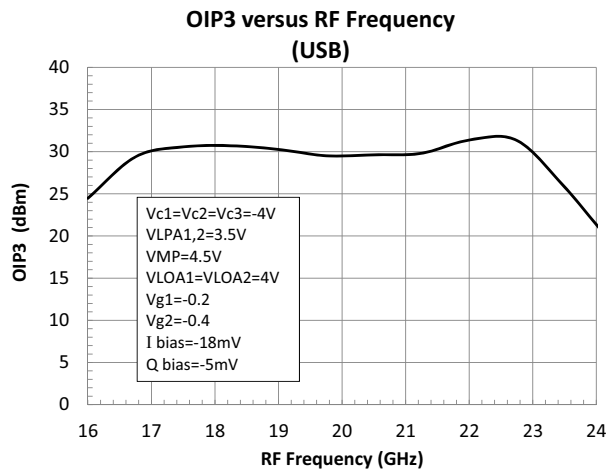
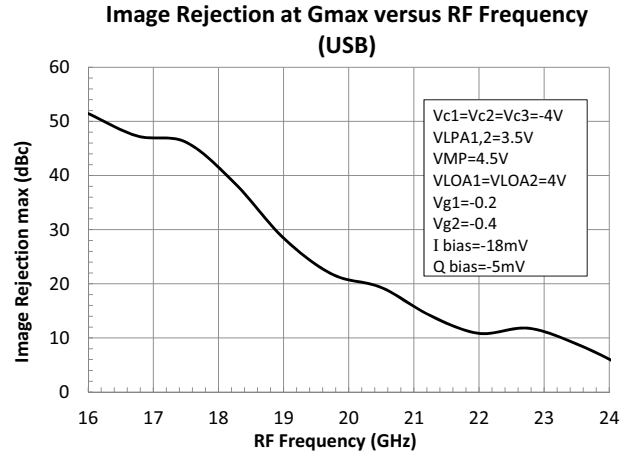
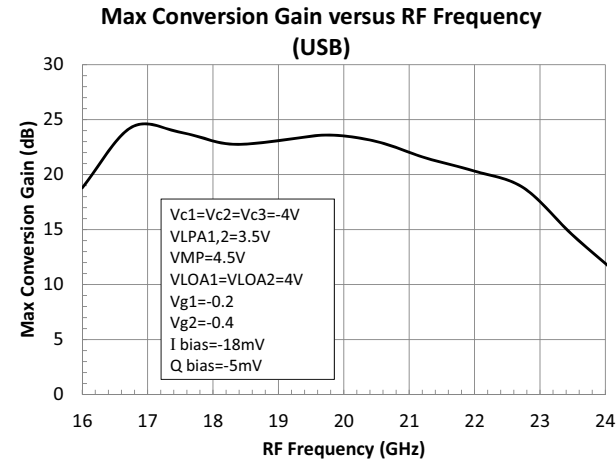

## LSB Conversion Gain, Image Rejection, OIP3 and LO Leakage

**Max Conversion Gain versus RF Frequency (LSB)**

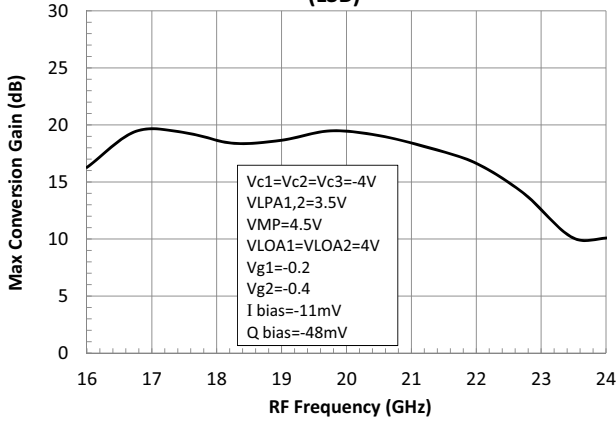

**Image Rejection at Gmax versus RF Frequency (LSB)**

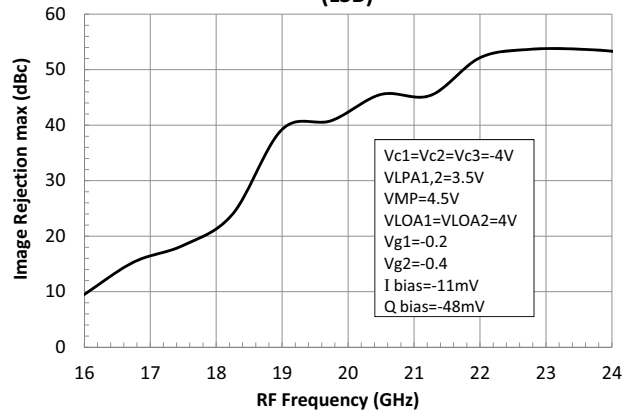

**OIP3 versus RF Frequency (LSB)**

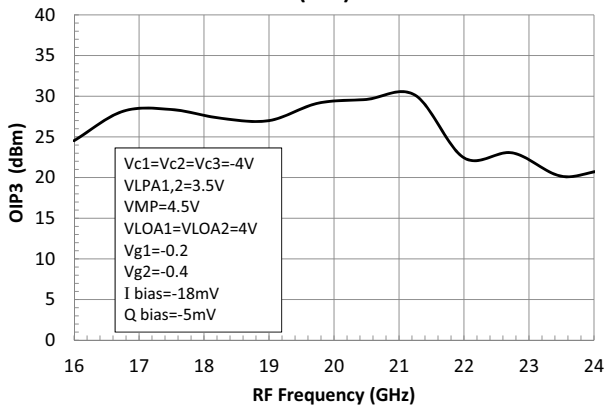

**OIP3 versus Conversion Gain (LSB 18GHz Band)**

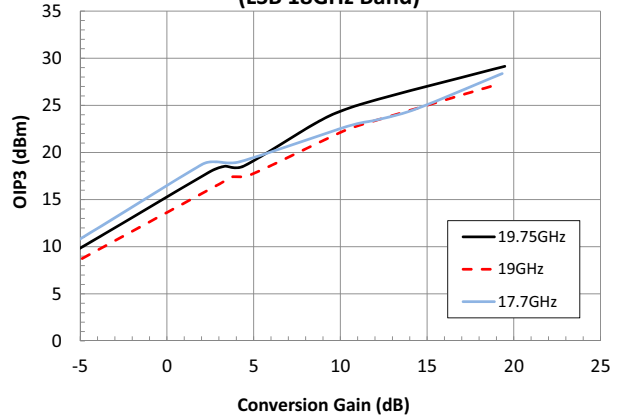

**x2LO Leakage at Gmax versus x2LO Frequency (LSB 18GHz Band)**

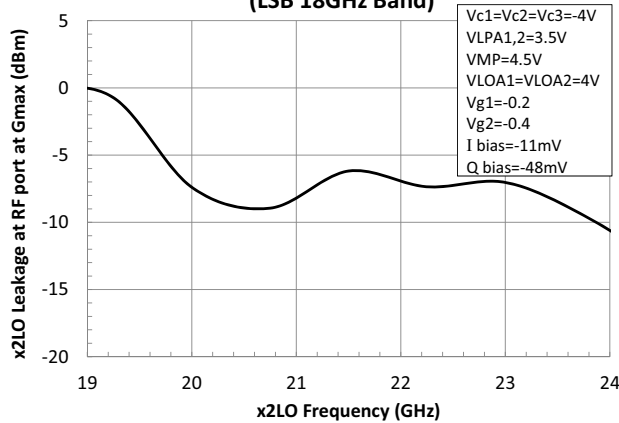

**Bias Sequence and Gain Control**

Optimum performance is achieved using sequential bias. At maximum gain ( $V_{C1}$ ,  $V_{C3}$ ), and  $V_{C2}$  are set at -4V and  $V_{G2}$  is set at -0.4V. ( $V_{C1}$ ,  $V_{C3}$ ),  $V_{C2}$  and  $V_{G2}$  are biased in sequence. The first dynamic range is achieved by setting ( $V_{C2}$  at -4V and  $V_{G2}$  at -0.4V) and varying ( $V_{C1}$ ,  $V_{C3}$ ) over the (-4 to -1V) range as shown in the table below. Similarly, the second dynamic range is achieved by setting ( $V_{C1}$ ,  $V_{C3}$ ) at -1V,  $V_{G2}$  at -0.4V and varying  $V_{C2}$  over the (-4 to -0.3V) range. Finally, the third dynamic range is achieved by setting ( $V_{C1}$ ,  $V_{C3}$ ) at -1V,  $V_{C2}$  at -0.3V and varying  $V_{G2}$  over the (-0.4 to -1V) range.

**Test Conditions and Bias Sequence**

Bias Sequence										
	$G_{MAX}$									$G_{MIN}$
( $V_{C1}$ , $V_{C3}$ )	-4	-2	-1	-1	-1	-1	-1	-1	-1	-1
$V_{C2}$	-4	-4	-4	-2	-1	-0.3	-0.3	-0.3	-0.3	-0.3
$V_{G2}$	-0.4	-0.4	-0.4	-0.4	-0.4	-0.4	-0.6	-0.8	-0.9	-1

**Package Outline Drawing**

QFN, 32-Pin, 5mm x 5mm x 0.95mm

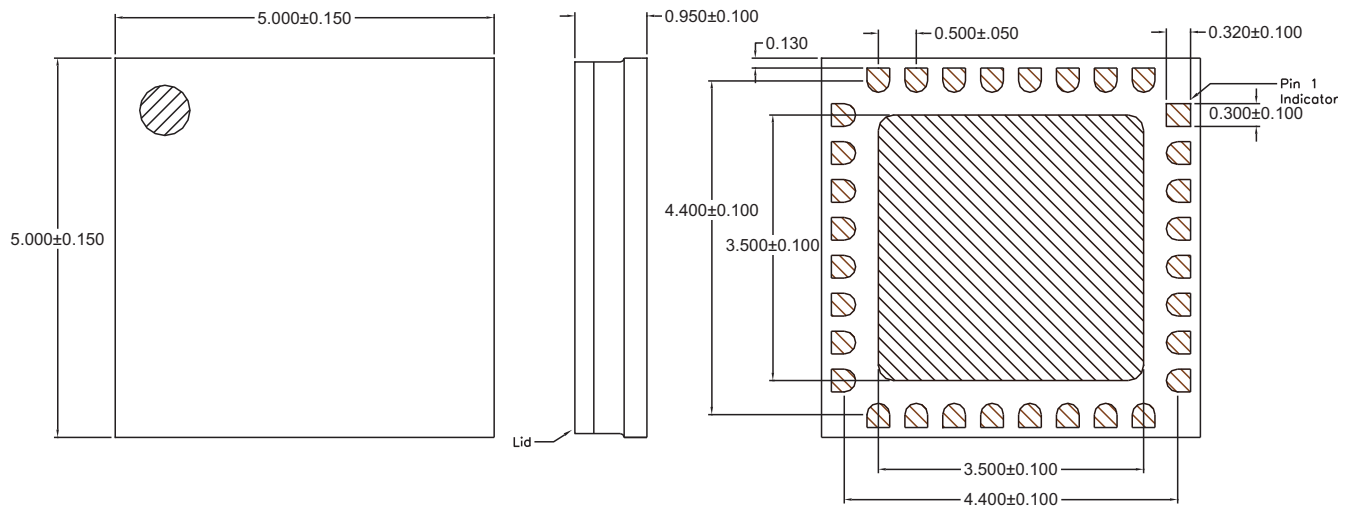

## Pin Names and Description

Pin	Function	Description
1	N/C	Not Connected
2	GND	Ground
3	LO	Local Oscillator Input. AC Coupled and Matched to 50Ω
4	GND	Ground
5	N/C	Not Connected
6	N/C	Not Connected
7	N/C	Not Connected
8	N/C	Not Connected
9	VLOA1	LOA Stage1 Drain Bias
10	VLOA2	LOA Stage2 Drain Bias
11	N/C	Not Connected
12	VC3	Control Line Number 3 (See Bias Sequence Description)
13	VC1	Control Line Number 1 (See Bias Sequence Description)
14	VC2	Control Line Number 2 (See Bias Sequence Description)
15	VG2	MPA Gate Bias
16	VMPA	MPA Drain Bias
17	N/C	Not Connected
18	GND	Ground
19	RFOUT	RF Output. AC Coupled and Matched to 50Ω
20	GND	Ground
21	N/C	Not Connected
22	N/C	Not Connected
23	N/C	Not Connected
24	VLPA1, VLPA2	LPA Stage 1, 2 Drain Bias
25	VG1	LPA Stage 1, 2 Gate Bias
26	N/C	Not Connected
27	Q	IF Q Input
28	GND	Ground
29	N/C	Not Connected
30	I	IF I Input
31	GND	Ground
32	N/C	Not Connected

**Application Circuit Block Diagram**

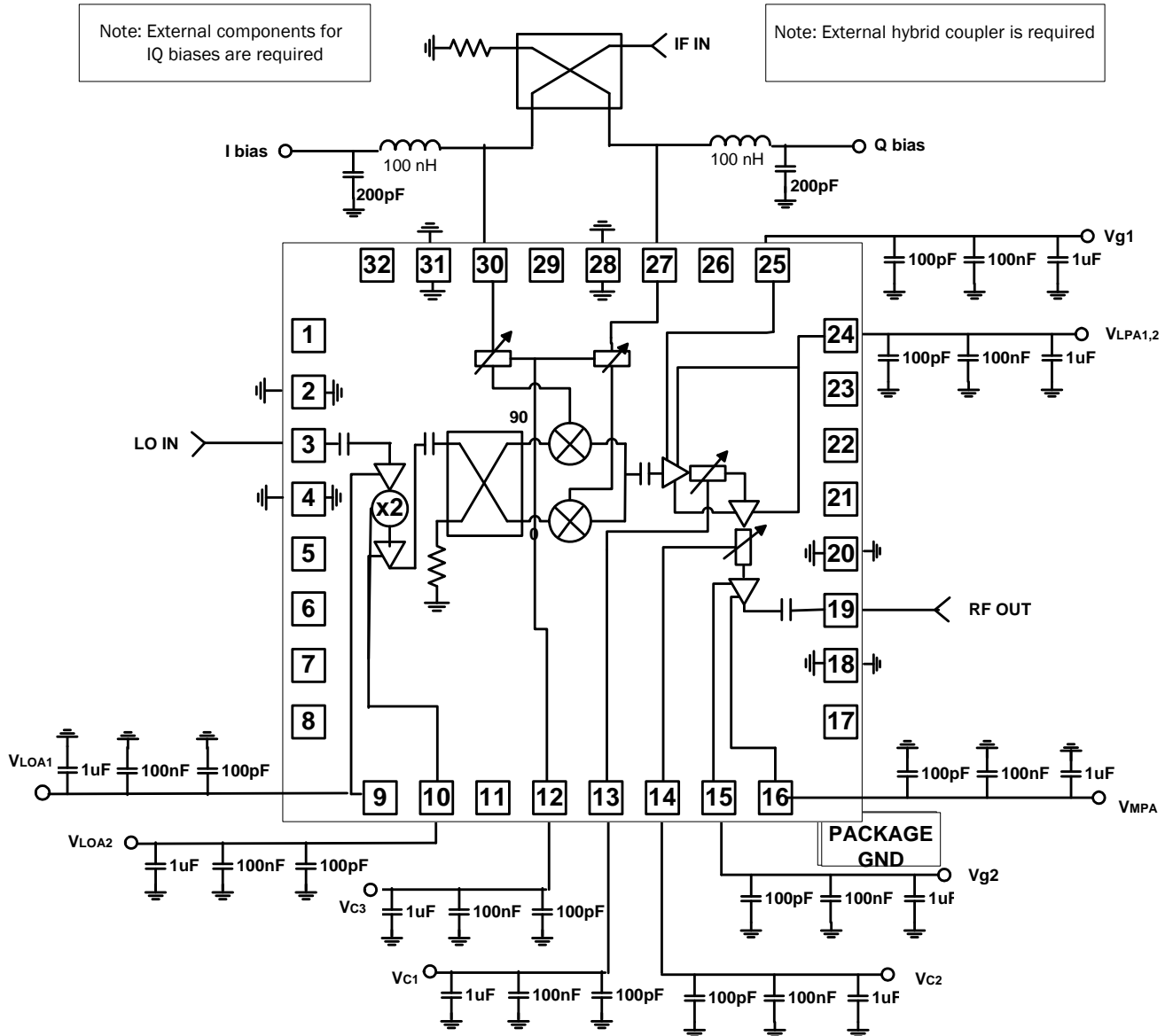

## Evaluation Board Layout

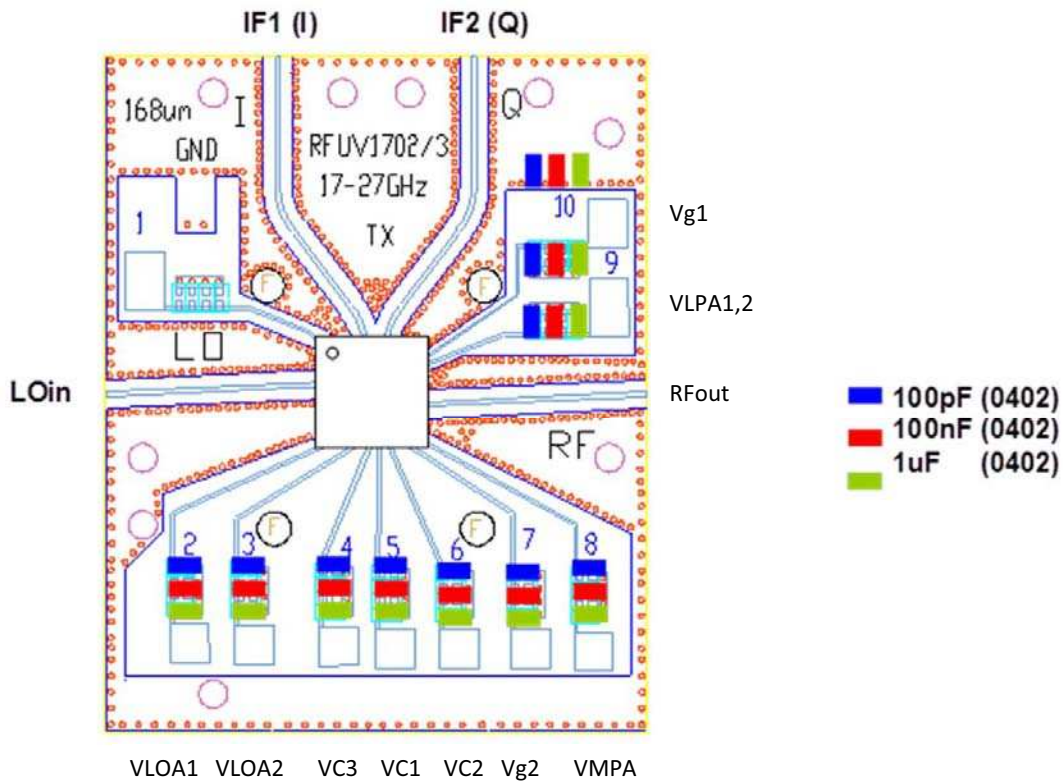

### Test Condition

LO Power	0dBm
IF Power	-10dBm
VMPA	4.5V
VLPA1, VLPA2	3.5V
VLOA1, VLOA2	4V
V <sub>C1</sub> , V <sub>C3</sub>	-4V to 1V
V <sub>C2</sub>	-4V to 0.3V
V <sub>G1</sub>	-0.2V
V <sub>G2</sub>	-0.4V to 1V